

Deutsches Institut für Bautechnik

Anstalt des öffentlichen Rechts

Kolonnenstr. 30 L
10829 Berlin
Germany

Tel.: +49(0)30 787 30 0
Fax: +49(0)30 787 30 320
E-mail: dibt@dibt.de
Internet: www.dibt.de



DIBt

Mitglied der EOTA
Member of EOTA

European Technical Approval ETA-09/0204

English translation prepared by DIBt - Original version in German language

Handelsbezeichnung
Trade name

WOLFIN Bautechnik Bahnsysteme (ETAG 006)

Zulassungsinhaber
Holder of approval

Henkel AG & Co. KGaA
Wolfen Bautechnik
Am Rosengarten 5
63607 Wächtersbach-Neudorf
DEUTSCHLAND

Zulassungsgegenstand
und Verwendungszweck
*Generic type and use
of construction product*

Mechanisch befestigte Dachabdichtungssysteme
Systems of mechanically fastened roof waterproofing membranes

Geltungsdauer: vom
Validity: from
bis
to

7 December 2009
20 July 2014

Herstellwerke
Manufacturing plants

Werk 01
Werk 02

Diese Zulassung umfasst
This Approval contains

26 Seiten einschließlich 12 Anhänge
26 pages including 12 annexes

Diese Zulassung ersetzt
This Approval replaces

ETA-09/0204 mit Geltungsdauer vom 21.07.2009 bis 20.07.2014
ETA-09/0204 with validity from 21.07.2009 to 20.07.2014



Europäische Organisation für Technische Zulassungen
European Organisation for Technical Approvals

I LEGAL BASES AND GENERAL CONDITIONS

- 1 This European technical approval is issued by Deutsches Institut für Bautechnik in accordance with:
 - Council Directive 89/106/EEC of 21 December 1988 on the approximation of laws, regulations and administrative provisions of Member States relating to construction products¹, modified by Council Directive 93/68/EEC² and Regulation (EC) N° 1882/2003 of the European Parliament and of the Council³;
 - Gesetz über das In-Verkehr-Bringen von und den freien Warenverkehr mit Bauprodukten zur Umsetzung der Richtlinie 89/106/EWG des Rates vom 21. Dezember 1988 zur Angleichung der Rechts- und Verwaltungsvorschriften der Mitgliedstaaten über Bauprodukte und anderer Rechtsakte der Europäischen Gemeinschaften (Bauproduktengesetz - BauPG) vom 28. April 1998⁴, as amended by law of 31 October 2006⁵;
 - Common Procedural Rules for Requesting, Preparing and the Granting of European technical approvals set out in the Annex to Commission Decision 94/23/EC⁶;
 - Guideline for European technical approval of "Systems of mechanically fastened flexible roof waterproofing membranes", ETAG 006.
- 2 Deutsches Institut für Bautechnik is authorized to check whether the provisions of this European technical approval are met. Checking may take place in the manufacturing plant. Nevertheless, the responsibility for the conformity of the products to the European technical approval and for their fitness for the intended use remains with the holder of the European technical approval.
- 3 This European technical approval is not to be transferred to manufacturers or agents of manufacturers other than those indicated on page 1, or manufacturing plants other than those indicated on page 1 of this European technical approval.
- 4 This European technical approval may be withdrawn by Deutsches Institut für Bautechnik, in particular pursuant to information by the Commission according to Article 5(1) of Council Directive 89/106/EEC.
- 5 Reproduction of this European technical approval including transmission by electronic means shall be in full. However, partial reproduction can be made with the written consent of Deutsches Institut für Bautechnik. In this case partial reproduction has to be designated as such. Texts and drawings of advertising brochures shall not contradict or misuse the European technical approval.
- 6 The European technical approval is issued by the approval body in its official language. This version corresponds fully to the version circulated within EOTA. Translations into other languages have to be designated as such.

1 Official Journal of the European Communities L 40, 11 February 1989, p. 12

2 Official Journal of the European Communities L 220, 30 August 1993, p. 1

3 Official Journal of the European Union L 284, 31 October 2003, p. 25

4 *Bundesgesetzblatt Teil I 1998*, p. 812

5 *Bundesgesetzblatt Teil I 2006*, p.2407, 2416

6 Official Journal of the European Communities L 17, 20 January 1994, p. 34

II SPECIFIC CONDITIONS OF THE EUROPEAN TECHNICAL APPROVAL

1 Definition of product and intended use

1.1 Definition of the construction product

The mechanical fastened flexible roof waterproofing kit "Wolfen Bautechnik Bahnsysteme (ETAG 006)" consists of kits of different flexible waterproofing sheets on the basis of Poly-Vinyl-Chlorine (PVC), clad with polyester fleece or clutched based on non-woven glass fibre and a set of fasteners and washers.

The kit with the components waterproofing sheets and point fasteners with washers can be assembled for creating the mechanically fastened one layer roof waterproofing system.

The waterproofing sheets WOLFEN M and TECTOFIN RV are compatible with bitumen. The waterproofing sheet COSMOFIN GG is not compatible with bitumen.

The insulation material is not a component of the kit.

1.1.1 Waterproofing sheet

The waterproofing sheets WOLFEN M, TECTOFIN RV and COSMOFIN GG are CE-marked according to EN 13956⁷. The manufacturer has given a declaration of conformity

The waterproofing sheets are delivered in rolls with a maximum length of 20 m meters. The waterproofing sheets are available in various widths. The maximum width is 1,62 meters.

The manufacturers declared value (MDV) of the effective thickness of the waterproofing layer is 1,2 mm, 1,5 mm, 1,8 mm and 2,0 mm. The waterproofing layer can be clad with polyester fleece or clutched based on non-woven glass fibre.

The joints overlap of the waterproofing sheet shall be welded with hot air or with solvent with minimum width of 20 mm respectively 30 mm.

The minimum of the joint overlap is 100 mm.

Table 1 gives the general description of the flexible waterproofing sheets. The accompanying mechanical characteristics are stated in the annexes 2, 3 and 4.

Table 1: Waterproofing sheets

Membrane	Cladding/Backing layer [g/m ²]	effective thickness of waterproofing layer without backing [mm]	Mass per unit area [g/m ²]
WOLFEN M	non-woven glass fibre approx. 85	1,5	1900
		2,0	2500
TECTOFIN RV	polyester fleece approx. 200	1,2	1650
		1,5	2000
COSMOFIN GG	non-woven glass fibre approx. 85	1,2	1600
		1,5	1900
		1,8	2300
		2,0	2500

1.1.2 Fasteners and washers

For fastening the waterproofing membrane to the substrate fasteners can be used from the manufacturer EJOT according to ETA-07/0013, from the manufacturer SFS intec according to ETA-08/0321 and from the manufacturer Zahn according to ETA-08/0033. The fasteners are CE-marked on the basis of the relevant approvals.

The different fasteners are stated in table 2.

The different washers are stated in table 3.

⁷ EN 13956:2007 "Flexible sheet for waterproofing - Plastic and rubber sheets for roof waterproofing - Definitions and characteristics

Table 2: Fasteners and washers

Trade name	Type	Nature	Geometry
EJOT Dabo SW 8 R 4,8 x L	screw	coated carbon steel	4,8 x L mm
EJOT Dabo SW 8 RT 4,8 x L	screw	stainless steel	4,8 x L mm
EJOT Dabo TKR-4,8 x L	screw	coated carbon steel	5,0 x L mm
EJOT Dabo TKE-4,8 x L	screw	stainless steel	5,0 x L mm
EJOT Dabo FBS-R-6,3 x L	screw	coated carbon steel	6,3 x L mm
EJOT Dabo FPS-E-8,0 x L	screw	stainless steel	8,0 x L mm
SFS IR2-4.8 x L	screw	coated carbon steel	4,8 x L mm
SFS IR2-S.4.8 x L	screw	stainless steel	4,8 x L mm
SFS IR3-4,8 x L	screw	coated carbon steel	4,8 x L mm
SFS IR3-S-4,8 x L	screw	stainless steel	4,8 x L mm
SFS IR2-C-4,8 x L	screw	coated carbon steel	4,8 x L mm
SFS IG-6 x L	screw	coated carbon steel	6,0 x L mm
SFS IW-T-5 x L	screw	coated carbon steel	5,0 x L mm
SFS IW-S-5 x L	screw	stainless steel	5,0 x L mm
SFS DT-4,8 x L	anchor	coated carbon steel	4,8 x L mm
SFS DT-S-4,8 x L	anchor	stainless steel	4,8 x L mm
SFS DT-6,3 x L	anchor	coated carbon steel	6,3 x L mm
SFS DT-S-6,3 x L	anchor	stainless steel	6,3 x L mm
SFS IE/15-6,3 x L	anchor	coated carbon steel	6,3 x L mm
SFS IGR-S-T25-8,0 x L	screw	stainless steel	8,0 x L mm
Zahn ZHBK	screw	carbon steel specially corrosion-protected	4,8 x L mm
Zahn ZKSK*	washer	plastic material	40 x 80 mm
	screw	carbon steel specially corrosion-protected	4,8 x L mm
Zahn ZKSK-R*	washer	plastic material	∅ 50mm x L mm
	screw	carbon steel specially corrosion-protected	4,8 x L mm
Zahn ZDBK-E	screw	carbon steel specially corrosion-protected	4,8 x L mm
Zahn ZKSK-E*	washer	plastic material	40 x 80 mm
	screw	carbon steel specially corrosion-protected	4,8 x L mm
Zahn ZKSK-E/R*	washer	plastic material	∅ 50mm x L mm
	screw	stainless steel	4,8 x L mm
Zahn ZDKB-F1	screw	carbon steel specially corrosion-protected	4,8 x L mm
Zahn ZKSK-F1*	washer	plastic material	40 x 80 mm
	screw	carbon steel specially corrosion-protected	4,8 x L mm
Zahn ZKSK-R-F1*	washer	plastic material	∅ 50mm x L mm
	screw	carbon steel specially corrosion-protected	4,8 x L mm
Zahn ZDKB-F2	screw	carbon steel specially corrosion-protected	4,8 x L mm
Zahn ZKSK-F2	washer	plastic material	40 x 80 mm
	screw	carbon steel specially corrosion-protected	4,8 x L mm
Zahn ZKSK-R-F2*	washer	plastic material	∅ 50mm x L mm
	screw	carbon steel specially corrosion-protected	4,8 x L mm
Zahn ZDKB-F3	screw	carbon steel specially corrosion-protected	4,8 x L mm

Trade name	Type	Nature	Geometry
Zahn ZKSK-F3*	washer	plastic material	40 x 80 mm
	screw	carbon steel specially corrosion-protected	4.8 x L mm
Zahn ZKSK-R-F3*	washer	plastic material	∅ 50mm x L mm
	screw	carbon steel specially corrosion-protected	4.8 x L mm
Zahn ZDBS	screw	carbon steel specially corrosion-protected	4.8 x L mm
Zahn ZHBK	screw	carbon steel specially corrosion-protected	4.8 x L mm
Zahn ZHSK*	washer	plastic material	40 x 80 mm
	screw	carbon steel specially corrosion-protected	4.8 x L mm
Zahn ZHSK-R*	washer	plastic material	∅ 50mm x L mm
	screw	carbon steel specially corrosion-protected	4.8 x L mm
Zahn ZHBK-E	screw	carbon steel specially corrosion-protected	4.8 x L mm
Zahn ZHSK-E*	washer	plastic material	40 x 80 mm
	screw	carbon steel specially corrosion-protected	4.8 x L mm
Zahn ZHSK-E/R*	washer	plastic material	∅ 50mm x L mm
	screw	carbon steel specially corrosion-protected	4.8 x L mm
Zahn ZSDK*	washer	plastic material	40 x 80 mm
	screw	carbon steel specially corrosion-protected	4.8 x L mm
Zahn ZSDK-R*	washer	plastic material	∅ 50mm x L mm
	screw	carbon steel specially corrosion-protected	4.8 x L mm
Zahn ZTSD*	washer	plastic material	40 x 80 mm
	screw	carbon steel specially corrosion-protected	4.8 x L mm
Zahn ZGBK-E	screw	carbon steel specially corrosion-protected	6,0 x L mm
Zahn ZDBK	screw	carbon steel specially corrosion-protected	4.8 x L mm
Zahn ZKGK-E/R*	washer	plastic material	40 x 80 mm
	screw	carbon steel specially corrosion-protected	6.0 x L mm
Zahn ZBST	screw	carbon steel specially corrosion-protected	6.3 x L mm
Zahn ZBSK-R*	washer	plastic material	∅ 50mm x L mm
	screw	carbon steel specially corrosion-protected	4.8 x L mm

* Combination of fastener and dowel with washer

Table 3: Washers

Trade name	Type	Nature	Geometry
EJOT HTV 82/40	washer	carbon steel, alu-zinc-coated	82 x 40 mm
EJOT HTK	washer	Polyamid	ø 50mm, L mm
EJOT EcoTek 50 x L	washer	Polyethylene	ø 50mm, L mm
EJOT HTV 82/40 TK	washer	carbon steel, alu-zinc-coated	82 x 40 mm
EJOT HTV 82/40 F	washer	carbon steel, alu-zinc-coated	82 x 40 mm
EJOT HTV 40 RU 6,5 mm	washer	carbon steel, alu-zinc-coated	ø 40mm, L mm
SFS IR-82 x 40	washer	steel plate with aluzinc protection	82 x 40 mm
SFS IRC/W-82x40	washer	steel plate with aluzinc protection	82 x 40 mm
SFS IRD-82 x 40	washer	steel plate with aluzinc protection	82 x 40 mm
SFS TC-50-30	washer	steel plate with aluzinc protection	ø 48,5 mm
SFS IF/IG-C-82x40	washer	steel plate with aluzinc protection	82 x 40 mm
SFS IR-C-82x40	washer	steel plate with aluzinc protection	82 x 40 mm
SFS IG8-C-82x40	washer	steel plate with aluzinc protection	82 x 40 mm
Zahn ZLVT 0001	washer	carbon steel corrosion-protected	82 x 40 mm
Zahn ZLVT 0005	washer	carbon steel corrosion-protected	82 x 40 mm
Zahn ZLVT 0008	washer	carbon steel corrosion-protected	82 x 40 mm
Zahn ZLVT 0012	washer	carbon steel corrosion-protected	82 x 40 mm
Zahn ZLVT 0015	washer	carbon steel corrosion-protected	ø 50 mm

1.2 Intended use

The mechanically fastened flexible roof waterproofing system "Wolfen Bautechnik Bahnen-systeme (ETAG 006)" is intended to create a roof waterproofing for non-utilized roofs.

The roof waterproofing system can be installed on flat roofs to resist the passage of water to the building's internal structure, where requirements concerning safety in case of fire, hygiene, health and the environment and safety in use as well as the durability in the sense of the essential requirements N° 2 to N° 4 of the Directive 89/106/EEC shall be satisfied.

In the manufacturer's technical dossier⁸ (MTD) to this European technical approval (ETA) the manufacturer gives information concerning the substrates which the mechanically waterproofing system is suitable for and how these substrates shall be pretreated.

The possible substrates are steel decks, concrete, aerated concrete or timber.

The insulation material must be CE marked according to the relevant harmonized European standards and shall have a minimum stiffness as stated in clause 4.2.

The provisions made in this ETA are based on an assumed intended working life of the mechanically fastened waterproofing system of 10 years, provided that the roof waterproofing kit is subjected to appropriate installation, use and maintenance. These provisions are based upon the current state of the art and the available knowledge and experience. When this expected working life has elapsed, the product may, under normal use conditions, keep his functionality even for a longer period without major affecting the essential requirements.

"Assumed intended working life" means that it is expected that, when this working life has elapsed, the real working life may be, under normal use conditions, considerably longer without major degradation affecting the essential requirements.

The indications given on the working life cannot be interpreted as a guarantee given by the producer, but are to be regarded only as a means for choosing the right products in relation to the expected economically reasonable working life of the works.

⁸ The manufacturer's technical dossier (MTD) comprises all information necessary for the production and the installation of the product as well as for the repair of the waterproofing system made from that. It was checked by DIBt and it was found to be in accordance with the conditions stated in the approval and the characteristic values determined during the approval testing.

The part of MTD to this ETA to be treated confidentially (inter alia the control plan for factory production control) is deposited with DIBt and, as far as this is relevant for the tasks of the notified body involved in the procedure of attestation of conformity, shall be handed over to the notified body.

2 Characteristics of product and methods of verification

2.1 Characteristics of the roof waterproofing system

The components of the mechanically fastened roof waterproofing system show the characteristic values with respect to the permissible tolerances which are stated in the MTD to this ETA.

The composition and the characteristic values of durability of the sheets are confidential and deposited with DIBt.

The performance of the reaction to fire behavior of the waterproofing sheet leads to the classification in class E according to EN 13501-1⁹ This is part of the CE-marking of the sheet.

The classification of the external fire performance of the roof waterproofing system for the waterproofing of roofs according to EN 13501-5¹⁰ is not specified. Option class F_{ROOF} is taken. The classifications and the system build-up are given in Annex 1.

According to the manufacturer's declaration the mechanically fastened roof waterproofing system does not contain any dangerous substances taking account of the EU database¹¹.

Within the scope of this approval there may be other requirements applicable to dangerous substances resulting from transposed European legislation or applicable national laws, regulations and administrative provisions.

There may be other requirements applicable to the products resulting from other applicable national laws, regulations and administrative provisions and transposed European legislation.

These requirements need also to be complied with, when and where they apply.

The characteristic values of the CE-marked waterproofing sheets in accordance with EN 13956 are given in annex 2 and 4.

The required characteristic values of the waterproofing sheets and the assembled kits according ETAG 006 are verified by the approval testing and are given in the annexes 2, 3 and 4. They fulfil the requirements of the ETAG 006. An evaluation for the intended use of the waterproofing system can be carried out with them by the user taking account of national requirements of member states where the product shall be used.

The admissible combinations of sheets and fasteners including washer and the admissible design values for wind loading (w_{adm}) of the assembled system are given in the annexes 5 and 6.

The permissible tolerances do not affect the characteristics of the products and the assembled system negatively.

2.2 Methods of verification

Assessment of the fitness of the roof waterproofing system for the intended use with regard to the essential requirements N° 2 to N° 4 was performed following the ETAG 006¹².

9 EN 13501-1:2007 "Fire classification of construction products and building elements - Part 1: Classification using data from reaction to fire tests"

10 EN 13501-5:2005 "Fire classification of construction products and building elements - Part 5: Classification using data from external fire exposure to roofs tests"

11 Notes are stated in Guidance Paper H: A harmonized approach relating to Dangerous substances under the construction product directive, Brussels, 18 February 2000

12 "ETAG 006 - Leitlinie für die europäische technische Zulassung für mechanisch befestigte Dachabdichtungssysteme", March 2000

3 Evaluation and attestation of conformity and CE marking

3.1 System of attestation of conformity

According to the Decision 98/143/EC of the European Commission¹³ system 2+ for the procedure of attestation of conformity (Annex III, clause 2(ii) first possibility of Directive 89/106/EEC) applies for mechanically fastened roof waterproofing system.

The system 2+ of attestation of conformity is defined as follows:

System 2+: Declaration of conformity of the product by the manufacturer on the basis of:

(a) Tasks for the manufacturer:

- (1) initial type-testing of the product;
- (2) factory production control;
- (3) testing of samples taken at the factory in accordance with a prescribed test plan.

(b) Tasks for the notified body:

- (4) certification of factory production control on the basis of:
 - initial inspection of factory and of factory production control;
 - continuous surveillance, assessment and approval of factory production control.

3.2 Responsibilities

For the components are provided that the attestation of conformity processes according to EN 13956 respectively to the relevant ETAs are verified on basis of these technical specifications. The attestation of conformity is only related to the additional to EN 13956 required characteristics according ETAG 006 and to assemble the components to the kit according annex 5 and 6. It shall be done by the declaration of conformity and the CE marking of the kit by the manufacturer according to clause 3.3 respectively 3.2.1.3.

3.2.1 Task of the manufacturer

3.2.1.1 Factory production control

The manufacturer shall exercise permanent internal control of production. All the elements, requirements and provisions adopted by the manufacturer shall be documented in a systematic manner in the form of written policies and procedures, including records of results performed. This production control system shall insure that the product is in conformity with this ETA.

The factory production control shall be in accordance with the appropriate part of the control plan¹⁴.

The factory production control is in conformity with ETAG 006.

The manufacturer may only use components according to this ETA. He shall inspect or control the initial materials on acceptance according to the control plan.

The results of the factory production control shall be recorded and evaluated in accordance with the provisions of the control plan.

The records shall include at least the following information:

- Name of the product,
- type of inspection or control,
- date of manufacture of the product, batch N° if needed, and date of inspection or control of the product,

¹³ Official Journal of the European Communities L 42, 14 February 1998

¹⁴ The control plan is a confidential part of the MTD to this ETA and deposited also with DIBt. It contains the required information on the factory production control, on the initial type-testing and the initial inspection of the factory and the continuous surveillance, assessment and approval of factory production control. As far as this is relevant to the tasks of the notified body involved in the procedure of attestation of conformity the control plan shall be handed over to the notified body.

- result of inspections or controls and, as far as applicable, comparison with the requirements,
- signature of the person responsible for the factory production control.

The records shall be kept for at least five years. On request they shall be presented to DIBt.

Details concerning extent, type and frequency of the tests or inspections to be performed within the scope of the factory production control shall correspond to the control plan which is part of the MTD to this ETA.

3.2.1.2 Initial type-testing of the product

The initial type-testing refers to the product properties stated in the appropriate part of the control plan to this ETA. The initial type-testing is conform to ETAG 006.

If the verifications underlying this ETA have been furnished on sheets from the current production, these will replace the initial type-testing.

Otherwise the necessary initial type-testing shall be carried out according to the provisions of the control plan and observance of the required property values shall be ascertained by the manufacturer.

After changing the composition or the production process of the waterproofing sheets, which may have influence on the proved characteristic values of durability according ETAG 006 the initial type-testing shall be repeated.

3.2.1.3 Other tasks for the manufacturer

The manufacturer shall, on the basis of a contract, involve a body which is notified for the tasks referred to in section 3.1 in the field of the product in order to undertake the actions laid down in section 3.2.2. For this purpose, the control plan referred to in section 3.2.2 shall be handed over by the manufacturer to the notified body involved.

The manufacturer shall make a declaration of conformity, stating that the product is in conformity with the provisions of this ETA. The declaration of conformity shall be accompanied by the factory production control certificate.

3.2.2 Task of the notified body

3.2.2.1 Initial inspection of factory and factory production control

The appropriate part of the control plan states the information on the properties which have to be controlled by the notified body involved for initial inspection of factory and factory production control. The notified body has to control the devices and equipments and the documentation of the factory production control of the manufacturer when starting the production or starting a new production line.

The notified body shall retain the essential points of its actions referred to above and state the results obtained and conclusions drawn in a written report.

The notified certification body involved by the manufacturer shall issue an EC certificate of conformity of the factory production control stating the conformity with the provisions of this ETA.

3.2.2.2 Continuous surveillance, judgment and assessment of factory production control

The appropriate part of the control plan states the information on the properties which have to be checked by the notified body involved. The frequency of this tasks shall be twice a year.

The notified body shall retain the essential points of its actions referred to above and state the results obtained and conclusions drawn in a written report.

In cases where the provisions of this ETA and its control plan are no longer fulfilled the certification body involved shall withdraw the certification of conformity and inform DIBt without delay.

3.3 CE marking of the kits

The CE marking¹⁵ shall be affixed by the manufacturer on the packaging of the kits of the roof waterproofing "Wolfen Bautechnik Bahnsysteme (ETAG 006)" or its accompanying documents. The letters "CE" shall be followed by the identification number of the notified body, and be accompanied by the following additional information:

- name and address or identifying mark of the manufacturer,
- last two digits of the year in which the CE marking was affixed,
- number of the EC certificate for the factory production control,
- number of the European technical approval: ETA-09/00204
- number of the European technical approval guideline: ETAG 006.

The approved components shall be specified as belonging to the mechanically fastened roof waterproofing kit "Wolfen Bautechnik Bahnsysteme (ETAG 006)".

CE marking and accompanying information:

	Letters "CE"
<i>nnnn</i>	Identification number of notified body (system 2 +)
Henkel KGaA Bautechnik/Wolfen Am Rosengarten 5 63607 Wächtersbach-Neudorf Germany	Name and address of the producer
<i>09</i> <i>nnnn-CPD-xxxx</i>	two last digits of year of affixing CE marking number of the EC certificate for the FPC
ETA-09/0204 ETAG 006	ETA number ETAG number
Mechanically fastened roof waterproofing system Declared values of the product and design values of the system see Annexes of ETA-09/0204	intended use classification and characteristics of the product

4 Assumptions under which the fitness of the product for the intended use was favourably assessed

4.1 Manufacturing

The manufacturing of the kit is to assemble the components sheets and fasteners including washers according to the combinations given in annex 5 and 6 to the kit.

The ETA is issued for the kit on basis of agreed data/information about the components, which identify the kit that has been assessed and judged and which are deposited at DIBt. Planned changes to the components of the kit, which change the results of the production process and/or the properties of the product and which are not in line with the deposited data should be notified to DIBt before the changes are introduced. DIBt will decide whether or not such changes affect the ETA and consequently the validity of the CE marking on the basis of the ETA and if so whether further assessment or alterations to the ETA shall be necessary.

¹⁵ Notes on the CE marking are stated in Guidance Paper D "CE marking under the Construction Products Directive", Brussels, 1 August 2002

4.2 Design and dimensioning

The fitness for the respective use of the mechanically fastened roof waterproofing results from the admissible design values for the wind loads (W_{adm}) according annexes 5 till 6, if need be, taking account of national requirements.

Furthermore the details demonstrated according annexes 7 till 11 shall be considered.

The supplementing statements of the manufacturer stated in the MTD for design and application of the waterproofing system shall be considered.

Especially the following factors should be taken into account:

- dead and imposed loads,
- design with respect to the decisive wind pressure on roof areas,
- structural strength, stiffness and deflection limits,
- attachment of the roof deck to the structural framing,
- provision of insulation,
- assessment of condensation risk and provisions of vapour control layers,
- sound insulation,
- fire precaution,
- roof attachments, fixture and penetrations,
- falls and drainage,
- means of access for inspection and maintenance.

The substrate and if available the insulation onto which the waterproofing kit is to be laid should be able to carry the loads.

The compression behaviour of the insulation material shall be such that the insulation material on site has:

- a 10 % compression ≥ 60 kPa (EN 826¹⁶)
- a point load behaviour ≥ 500 Pa, deformation 5 mm (EN 12430¹⁷)

The insulation material must be CE marked according to the relevant harmonized European standard. The durability shall be assessed in accordance with these standards.

The thickness of the insulation material should be designed in accordance with national regulations.

4.3 Installation

The fitness for use of the mechanically fastened roof waterproofing system can be assumed only, if the installation is carried out according to the installation instructions stated in the MTD by the manufacturer, in particular taking account of the following points:

- installation by appropriately trained personnel,
- installation of only those components which are marked as components of the system,
- installation with the required tools and adjuvants,
- precautions during installation,
- inspecting the substrate surface for cleanliness and correct preparation,

¹⁶ EN 826:1996 "Thermal insulating products for building applications - Determination of compression behaviour"

¹⁷ EN 12430:1998 + A1:2006 "Thermal insulating products for building applications - Determination of behaviour under point load"

- inspecting compliance with suitable weather conditions, avoid installation when temperature falls under 5°C and the following weather conditions: high humidity, rain, snow or fog. By preheating the seam areas, welding is also possible at lower ambient temperatures,
- overlap: the longitudinal overlap between the sheets shall be always at least 100 mm and the joint can be welded with hot air and shall have at least 20 mm in width or can be welded with solvent and shall have at least 30 mm in width,
- overlap: when ends of fleece backed membranes are be joint (transversal-overlap), this is done by tightly butting the ends together and covering them with a 150 mm wide unbacked membrane-strip centrally welded over the joint with hot air or with solvent,
- inspections during installation and of the finished roof waterproofing system according TDM and documentation of the results.

The information as to the

- method of repair on site,
 - handling of waste products
- shall be observed.

4.4 Manufacturer's responsibilities

It is the manufacturer's responsibility to make sure that all who utilize the approved roof waterproofing system get all information about the components belonging to the kit and the installation instructions. So the user shall be appropriately informed about the specific conditions according to sections 1, 2, 4, and 5 including the annexes to this ETA.

5 Indications of the manufacturer

5.1 Packaging, transport and storage

Information on:

- Packaging
- transport and
- storage

are given in the MTD.

5.2 Use, maintenance and repair

Information on:

- Use
- maintenance
- repair

are given in the MTD.

Dipl.-Ing. G. Breitschaft
President of Deutsches Institut für Bautechnik
Berlin, 7 December 2009

beglaubigt
Dipl.-Ing. B. Hemme

DEUTSCHES INSTITUT FÜR BAUTECHNIK

System build-up of the roof waterproofing Wolfin Bautechnik Bahnsysteme (ETAG 006)

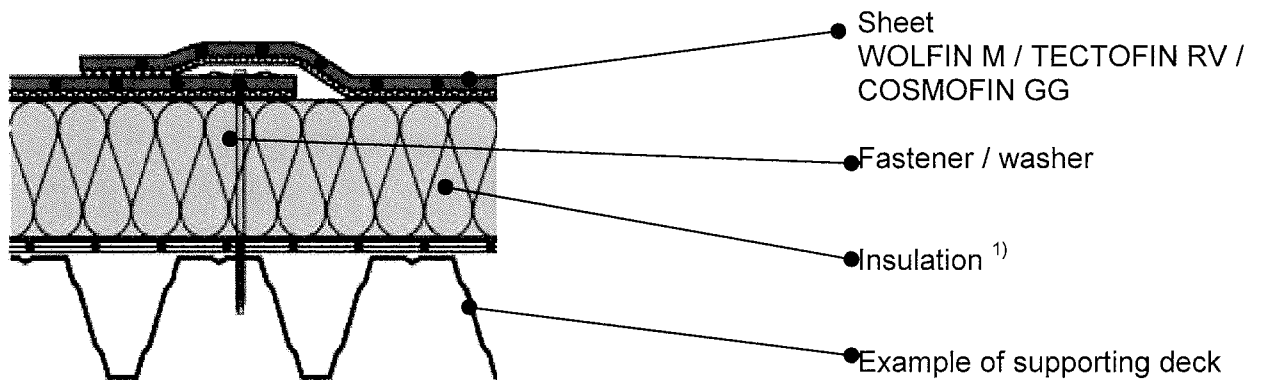

¹⁾ It shall be ensured that the insulation material on site has:

- a 10 % compression ≥ 60 kPa (EN 826)
- a point load behaviour ≥ 500 Pa, deformation 5mm (EN 12430)

The insulation material must be CE marked according to the relevant harmonized European standard.

Reaction to fire

class E according to EN 13501-1

External fire performance of roofs

option class F_{ROOF} according to EN 13501-5

Information for users on external fire performance of roof decks:

The classifications according EN V 1187 and according EN 13501-5, which are given in classification documents, are only valid for the roof systems stated in these documents.

Henkel KGaA
 Bautechnik/Wolfin
 Am Rosengarten 5
 63607 Wächtersbach-Neudorf
 Germany

Wolfin Bautechnik Bahnsysteme
 (ETAG 006)
System build-up

Annex 1
 Mechanically fastened
 roof waterproofing system

European technical approval
 N° ETA-09/0204
 dated 7 December 2009

DEUTSCHES INSTITUT FÜR BAUTECHNIK

Waterproofing sheet WOLFIN M

backing layer [g/m ²]	effective thickness [mm]	mass per unit area [g/m ²]
non-woven glass fibre approx. 85	1,5	1900
	2,0	2500

Characteristic	test method	dimension	value	value	expression
thickness ¹⁾	EN 1849-2	mm	1,5 mm	2,0 mm	MDV
reaction to fire ¹⁾	EN 11925-2		class E	class E	EN 13501-1
water tightness ¹⁾	EN 1928 test B	kPa			MLV
peel resistance of joints ¹⁾	EN 12316-2	N/50 mm	≥ 300	≥ 300	MLV
shear resistance of joints ¹⁾	EN 12317-2	N/50 mm	≥ 800	≥ 800	MLV
tensile strength ¹⁾	EN 12311-2	N/50 mm	≥ 800	≥ 800	MLV
tensile elongation ¹⁾	EN 12311-2	%	≥ 2	≥ 2	MLV
resistance against dynamic indentation ¹⁾	EN 12691 test A	mm	≥ 600	≥ 750	MLV
resistance against dynamic indentation ¹⁾	EN 12691 test B	mm	≥ 600	≥ 750	MLV
resistance against static indentation ¹⁾	EN 12730 test B	kg	≥ 20	≥ 20	MLV
resistance to tearing ¹⁾	EN 1310-2	N	≥ 250	≥ 250	MLV
dimensional stability ¹⁾	EN 1107-2	%	≤ 0,5	≤ 0,5	MLV
resistance to cold bending ¹⁾	EN 495-5	°C	≤ -20	≤ -20	MLV
resistance to UV radiation ¹⁾	EN 1297	visible			pass
resistance to hail ¹⁾	EN 13583	m/s	≥ 25	≥ 25	MLV
water vapour transmission ¹⁾	EN 1931	μ	ca. 10.000	ca. 10.000	MDV
exposure to bitumen ¹⁾	prEN 1584				pass
resistance to liquid chemicals including water ¹⁾	EN 1847				pass
root resistance ¹⁾	prEN 13948				pass
Resistance to heat ageing, EN 1296 ²⁾					
peel resistance of joints	EN 12316-2	%	Δ ≤ 20	Δ ≤ 20	pass
shear resistance of joints	EN 12317-2	%	Δ ≤ 20	Δ ≤ 20	pass
resistance to cold bending	EN 495-5	°C	Δ ≤ 15	Δ ≤ 15	pass
Resistance after long term exposure to heat UV (EN 1297) ²⁾					
resistance to cold bending	EN 495-5	°C	Δ ≤ 15	Δ ≤ 15	pass

¹⁾ These values are manufacturer values stated by the CE-marking according to EN 13956

²⁾ These values are determined in accordance with ETAG 006

Henkel KGaA
 Bautechnik/Wolfin
 Am Rosengarten 5
 63607 Wächtersbach-Neudorf
 Germany

Wolfin Bautechnik Bahnsysteme
 (ETAG 006)
Characteristics

Annex 2
 Mechanically fastened
 roof waterproofing system

 European technical approval
 N° ETA-09/0204
 dated 7 December 2009

DEUTSCHES INSTITUT FÜR BAUTECHNIK

Waterproofing sheet TECTOFIN RV

cladding layer [g/m ²]	effective thickness [mm]	mass per unit area [g/m ²]
polyester fleece, approx. 200	1,2	1650
	1,5	2000

Characteristic	test method	dimension	value	value	expression
thickness ¹⁾	EN 1849-2	mm	1,2 mm	1,5 mm	MDV
reaction to fire ¹⁾	EN 11925-2		class E	class E	EN 13501-1
water tightness ¹⁾	EN 1928 test B	kPa			pass
peel resistance of joints ¹⁾	EN 12316-2	N/50 mm	≥ 250	≥ 250	MLV
shear resistance of joints ¹⁾	EN 12317-2	N/50 mm	≥ 500	≥ 500	MLV
tensile strength ¹⁾	EN 12311-2	N/50 mm	≥ 600	≥ 600	MLV
tensile elongation ¹⁾	EN 12311-2	%	≥ 10	≥ 10	MLV
resistance against dynamic indentation ¹⁾	EN 12691 test A	mm	≥ 500	≥ 600	MLV
resistance against dynamic indentation ¹⁾	EN 12691 test B	mm	≥ 500	≥ 600	MLV
resistance against static indentation ¹⁾	EN 12730 test B	kg	≥ 20	≥ 20	MLV
resistance to tearing ¹⁾	EN 1310-2	N	≥ 250	≥ 250	MLV
dimensional stability ¹⁾	EN 1107-2	%	≤ 1	≤ 1	MLV
resistance to cold bending ¹⁾	EN 495-5	°C	≤ -25	≤ -25	MLV
resistance to UV radiation ¹⁾	EN 1297	visible			pass
resistance to hail ¹⁾	EN 13583	m/s	≥ 25	≥ 25	MLV
water vapour transmission ¹⁾	EN 1931	μ	ca. 20.000	ca. 20.000	MDV
exposure to bitumen ¹⁾	prEN 1584				pass
resistance to liquid chemicals including water ¹⁾	EN 1847				pass ³⁾
root resistance ¹⁾	prEN 13948				pass
Resistance to heat ageing, EN 1296 ²⁾					
peel resistance of joints	EN 12316-2	%	Δ ≤ 20	Δ ≤ 20	pass
shear resistance of joints	EN 12317-2	%	Δ ≤ 20	Δ ≤ 20	pass
resistance to cold bending	EN 495-5	°C	Δ ≤ 15	Δ ≤ 15	pass
Resistance after long term exposure to heat UV (EN 1297)²⁾					
resistance to cold bending	EN 495-5	°C	Δ ≤ 15	Δ ≤ 15	pass

¹⁾ These values are manufacturer values stated by the CE-marking according to EN 13956

²⁾ These values are determined in accordance with ETAG 006

Henkel KGaA
 Bautechnik/Wolfin
 Am Rosengarten 5
 63607 Wächtersbach-Neudorf
 Germany

Wolfin Bautechnik Bahnsysteme
 (ETAG 006)
Characteristics

Annex 3
 Mechanically fastened
 roof waterproofing system

 European technical approval
 N° ETA-09/0204
 dated 7 December 2009

DEUTSCHES INSTITUT FÜR BAUTECHNIK

Waterproofing sheet COSMOFIN GG

backing layer [g/m ²]	effective thickness [mm]	mass per unit area [g/m ²]
non-woven glass fibre approx. 85	1,2	1600
	1,5	1900
	1,8	2300
	2,0	2500

Characteristic	test method	Dimension	value	value	value	value	expression
thickness ¹⁾	EN 1849-2	mm	1,2 mm	1,5 mm	1,8 mm	2,0 mm	MDV
reaction to fire ¹⁾	EN 11925-2		class E	class E	class E	class E	EN 13501-1
water tightness ¹⁾	EN 1928 test B	kPa					pass
peel resistance of joints ¹⁾	EN 12316-2	N/50 mm	≥ 300	≥ 300	≥ 300	≥ 300	MLV
shear resistance of joints ¹⁾	EN 12317-2	N/50 mm	≥ 800	≥ 800	≥ 800	≥ 800	MLV
tensile strength ¹⁾	EN 12311-2	N/50 mm	≥ 800	≥ 800	≥ 800	≥ 800	MLV
tensile elongation ¹⁾	EN 12311-2	%	≥ 2	≥ 2	≥ 2	≥ 2	MLV
resistance against dynamic indentation ¹⁾	EN 12691 test A	mm	≥ 500	≥ 600	≥ 700	≥ 750	MLV
resistance against dynamic indentation ¹⁾	EN 12691 test A	mm	≥ 500	≥ 600	≥ 700	≥ 750	MLV
resistance against static indentation ¹⁾	EN 12730 test B	kg	≥ 20	≥ 20	≥ 20	≥ 20	MLV
resistance to tearing ¹⁾	EN 1310-2	N	≥ 250	≥ 250	≥ 250	≥ 250	MLV
dimensional stability ¹⁾	EN 1107-2	%	≤ 0,5	≤ 0,5	≤ 0,5	≤ 0,5	MLV
resistance to cold bending ¹⁾	EN 495-5	°C	≤ -20	≤ -20	≤ -20	≤ -20	MLV
resistance to UV radiation ¹⁾	EN 1297	visible					pass
resistance to hail ¹⁾	EN 13583	m/s	≥ 25	≥ 25	≥ 25	≥ 25	MLV
water vapour transmission ¹⁾	EN 1931	μ	ca. 25.000	ca. 25.000	ca. 25.000	ca. 25.000	MDV
resistance to liquid chemicals including water ¹⁾	EN 1847						pass ³⁾
root resistance ¹⁾	prEN 13948						pass
Resistance to heat ageing, EN 1296 ²⁾							
peel resistance of joint	EN 12316-2	%	Δ ≤ 20	Δ ≤ 20	Δ ≤ 20	Δ ≤ 20	pass
shear resistance of joints	EN 12317-2	%	Δ ≤ 20	Δ ≤ 20	Δ ≤ 20	Δ ≤ 20	pass
resistance to tearing	EN 1310-2	---				---	---
resistance to cold bending	EN 495-5	°C	Δ ≤ 15	Δ ≤ 15	Δ ≤ 15	Δ ≤ 15	pass
Resistance after long term exposure to heat UV (EN 1297) ²⁾							
resistance to cold bending	EN 495-5	°C	Δ ≤ 15	Δ ≤ 15	Δ ≤ 15	Δ ≤ 15	pass

¹⁾ These values are manufacturer values stated by the CE-marking according to EN 13956

²⁾ These values are determined in accordance with ETAG 006

Henkel KGaA
 Bautechnik/Wolfin
 Am Rosengarten 5
 63607 Wächtersbach-Neudorf
 Germany

Wolfin Bautechnik Bahnsysteme
 (ETAG 006)
Characteristics

Annex 4
 Mechanically fastened
 roof waterproofing system

 European technical approval
 N° ETA-09/0204
 dated 7 December 2009

DEUTSCHES INSTITUT FÜR BAUTECHNIK

Wind load per fastener waterproofing sheet WOLFIN M									
Screw	Washer	Metal sheet deck		Timber				Concret	Aerated concrete
		1	2	1	2	3	4	EN 206-1	
W_{adm} [N]									
EJOT Dabo SW 8 R 4,8 x L	HTV 82/40				540		--		
EJOT Dabo SW 8 RT 4,8 x L	HTV 82/40 F	540			540		--		
EJOT Dabo TKR-4,8 x L	EJOT HTK EJOT HTV 82/40 TK EJOT HTV 82/40 F EJOT HN 40 RU EJOT EcoTek 50 x L				540		--		
EJOT Dabo TKE-4,8 x L	EJOT HTK EJOT HTV 82/40 TK EJOT HTV 82/40 F EJOT HN 40 RU EJOT EcoTek 50 x L				540		--		
EJOT Dabo FBS-R-6,3 x L	EJOT HTV 82/40 F EJOT HN 40 RU EJOT EcoTek 50 x L							540 ¹⁾	
EJOT Dabo FPS-E-8,0 x L	EJOT HTV 82/40 F EJOT HN 40 RU EJOT EcoTek 50 x L								540 ³⁾
SFS IR2-4,8 x L	IR 82 x 40	540		540	--		540		
SFS IR2-S-4,8 x L	IR 82 x 40	540		540	--		540		
SFS IR3-4,8 x L	IR 82 x 40		540						
SFS IR3-S-4,8 x L	IR 82 x 40		540						
SFS IR2-C-4,8 x L	IRC/W-82x40	540		540	--		540		
SFS IG-6 x L	IRD-82 x 40						540		
SFS IW-T-5 x L	IRC/W-82x40						540		
SFS IW-S-5 x L	IRC/W-82x40						540		
SFS DT-4,8 x L	IRD-82 x 40 IF/IG-C-82 x 40 TC-50-30							540 ⁴⁾	
SFS DT-S-4,8 x L	IRD-82 x 40 IF/IG-C-82 x 40 TC-50-30							540 ⁴⁾	
SFS DT-6,3 x L	IRD-82 x 40 IF/IG-C-82 x 40 TC-50-30							540 ⁵⁾	
SFS DT-S-6,3 x L	IRD-82 x 40 IF/IG-C-82 x 40 TC-50-30							540 ⁵⁾	
SFS IE/15-6,3 x L	IRD-82 x 40 IR-C-82 x 42 TC-50-30							400 ⁶⁾	
SFS IGR-S-T25-8,0 x L	IG8-C-82 x 42								400 ³⁾
Zahn ZHBK	ZLVT 0001 ZLVT 0005 ZLVT 0015					540			
Zahn ZKSK	*	540							
Zahn ZKSK-R	*	540							
Zahn ZDBK-E	ZLVT 0001 ZLVT 0005 ZLVT 0015	540							
Zahn ZKSK-E	*	540							

Continued on Annex 5.2

<p>Henkel KGaA Bautechnik/Wolfin Am Rosengarten 5 63607 Wächtersbach-Neudorf Germany</p>	<p>Wolfen Bautechnik Bahnsysteme (ETAG 006) Admissible load per fastener</p>	<p>Annex 5.1 Mechanically fastened roof waterproofing system</p> <p>European technical approval N° ETA-09/0204 dated 7 December 2009</p>
---	--	---

DEUTSCHES INSTITUT FÜR BAUTECHNIK

Wind load per fastener waterproofing sheet WOLFIN M									
Screw	Washer	Metal sheet deck		Timber				Concrete	Aerated concrete
		1	2	1	2	3	4		
W_{adm} [N]									
Zahn ZKSK-E/R	*	540							
Zahn ZDKB-F1	ZLVT 0001 ZLVT 0005 ZLVT 0015	540							
Zahn ZKSK-F1	*	540							
Zahn ZKSK-R-F1	*	540							
Zahn ZDKB-F2	ZLVT 0001 ZLVT 0005 ZLVT 0015	540							
Zahn ZKSK-F2	*	540							
Zahn ZKSK-R-F2	*	540							
Zahn ZDKB-F3	ZLVT 0001 ZLVT 0005 ZLVT 0015	540							
Zahn ZKSK-F3	*	540							
Zahn ZKSK-R-F3	*	540							
Zahn ZDBS	ZLVT 0001 ZLVT 0005 ZLVT 0012	540							
Zahn ZHBK	ZLVT 0001 ZLVT 0005 ZLVT 0015				540				
Zahn ZHSK	*				540				
Zahn ZHSK-R	*				540				
Zahn ZHBK-E	ZLVT 0001 ZLVT 0005 ZLVT 0015				540				
Zahn ZHSK-E	*				540				
Zahn ZHSK-E/R	*				540				
Zahn ZSDK	*						540 ²⁾	540 ³⁾	
Zahn ZSDK-R	*						540 ²⁾	540 ³⁾	
Zahn ZTSD	*						540 ²⁾	540 ³⁾	
Zahn ZGBK-E	ZLVT 0008 ZLVT 0012							540 ³⁾	
Zahn ZKGG-E/R	*							540 ³⁾	
Zahn ZBST	ZLVT 0008 ZLVT 0012						540 ²⁾		
Zahn ZBSK-R	*						540 ²⁾		

* Combination of fastener and dowel with washer

Timber

- 1 structural timber EN 338/C24, $t \geq 22$ mm, effective embedment depth ≥ 22 mm
- 2 polywood BFU 100 EN 636, $t \geq 19$ mm, effective embedment depth ≥ 19 mm
- 3 OSB3 EN 300, $t \geq 18$ mm, effective embedment depth ≥ 18 mm
- 4 particle board EN 312/P5, $t \geq 19$ mm, effective embedment depth ≥ 19 mm

Sheet Deck

- 1 Steel S280GD – EN 10326, $t \geq 0,75$ mm
- 2 Steel S280GD – EN 10326, $t \geq 1,0$ mm

Concrete and aerated concrete

- ¹⁾ effective anchorage depth ≥ 30 mm
- ²⁾ effective anchorage depth ≥ 40 mm
- ³⁾ effective anchorage depth ≥ 60 mm
- ⁴⁾ effective anchorage depth ≥ 25 mm
- ⁵⁾ effective anchorage depth ≥ 32 mm
- ⁶⁾ effective anchorage depth ≥ 35 mm

Henkel KGaA
 Bautechnik/Wolfin
 Am Rosengarten 5
 63607 Wächtersbach-Neudorf
 Germany

Wolfin Bautechnik Bahnsysteme
 (ETAG 006)
Admissible load per fastener

Annex 5.2
 Mechanically fastened
 roof waterproofing system

European technical approval
 N° ETA-09/0204
 dated 7 December 2009

DEUTSCHES INSTITUT FÜR BAUTECHNIK

Wind load per fastener waterproofing sheet TECTOFIN RV and COSMOFIN GG									
Screw	Washer	Metal sheet deck		Timber				Concrete	Aerated concrete
		1	2	1	2	3	4		
W_{adm} [N]									
EJOT Dabo SW 8 R 4,8 x L	HTV 82/40				550		--		
EJOT Dabo SW 8 RT 4,8 x L	HTV 82/40 F	550			550		--		
EJOT Dabo TKR-4,8 x L	EJOT HTK EJOT HTV 82/40 TK EJOT HTV 82/40 F EJOT HN 40 RU EJOT EcoTek 50 x L				550		--		
EJOT Dabo TKE-4,8 x L	EJOT HTK EJOT HTV 82/40 TK EJOT HTV 82/40 F EJOT HN 40 RU EJOT EcoTek 50 x L				550		--		
EJOT Dabo FBS-R-6,3 x L	EJOT HTV 82/40 F EJOT HN 40 RU EJOT EcoTek 50 x L							550 ¹⁾	
EJOT Dabo FPS-E-8,0 x L	EJOT HTV 82/40 F EJOT HN 40 RU EJOT EcoTek 50 x L								550 ³⁾
SFS IR2-4.8 x L	IR 82 x 40	550		550	--		550		
SFS IR2-S.4.8 x L	IR 82 x 40	550		550	--		550		
SFS IR3-4,8 x L	IR 82 x 40		550						
SFS IR3-S-4,8 x L	IR 82 x 40		550						
SFS IR2-C-4,8 x L	IRC/W-82x40	550		550	--		550		
SFS IG-6 x L	IRD-82 x 40				--		550		
SFS IW-T-5 x L	IRC/W-82x40				--		550		
SFS IW-S-5 x L	IRC/W-82x40				--		550		
SFS DT-4,8 x L	IRD-82 x 40 IF/IG-C-82 x 40 TC-50-30							550 ⁴⁾	
SFS DT-S-4,8 x L	IRD-82 x 40 IF/IG-C-82 x 40 TC-50-30							550 ⁴⁾	
SFS DT-6,3 x L	IRD-82 x 40 IF/IG-C-82 x 40 TC-50-30							550 ⁵⁾	
SFS DT-S-6,3 x L	IRD-82 x 40 IF/IG-C-82 x 40 TC-50-30							550 ⁵⁾	
SFS IE/15-6,3 x L	IRD-82 x 40 IR-C-82 x 42 TC-50-30							400 ⁶⁾	
SFS IGR-S-T25-8,0 x L	IG8-C-82 x 42								400 ³⁾
Zahn ZHBK	ZLVT 0001 ZLVT 0005 ZLVT 0015				550				
Zahn ZKSK	*	550							
Zahn ZKSK-R	*	550							
Zahn ZDBK-E	ZLVT 0001 ZLVT 0005 ZLVT 0015	550							
Zahn ZKSK-E	*	550							

Continued on Annex 6.2

Henkel KGaA
 Bautechnik/Wolfin
 Am Rosengarten 5
 63607 Wächtersbach-Neudorf
 Germany

Wolfin Bautechnik Bahnsysteme
 (ETAG 006)
Admissible load per fastener

Annex 6.1
 Mechanically fastened
 roof waterproofing system
 European technical approval
 N° ETA-09/0204
 dated 7 December 2009

DEUTSCHES INSTITUT FÜR BAUTECHNIK

Wind load per fastener waterproofing sheet WOLFIN M									
Screw	Washer	Metal sheet deck		Timber				Concrete	Aerated concrete
		1	2	1	2	3	4		
W_{adm} [N]									
Zahn ZKSK-E/R	*	550							
Zahn ZDKB-F1	ZLVT 0001 ZLVT 0005 ZLVT 0015	550							
Zahn ZKSK-F1	*	550							
Zahn ZKSK-R-F1	*	550							
Zahn ZDKB-F2	ZLVT 0001 ZLVT 0005 ZLVT 0015	550							
Zahn ZKSK-F2	*	550							
Zahn ZKSK-R-F2	*	550							
Zahn ZDKB-F3	ZLVT 0001 ZLVT 0005 ZLVT 0015	550							
Zahn ZKSK-F3	*	550							
Zahn ZKSK-R-F3	*	550							
Zahn ZDBS	ZLVT 0001 ZLVT 0005 ZLVT 0012	550							
Zahn ZHBK	ZLVT 0001 ZLVT 0005 ZLVT 0015				550				
Zahn ZHSK	*				550				
Zahn ZHSK-R	*				550				
Zahn ZHBK-E	ZLVT 0001 ZLVT 0005 ZLVT 0015				550				
Zahn ZHSK-E	*				550				
Zahn ZHSK-E/R	*				550				
Zahn ZSDK	*						550 ²⁾	550 ³⁾	
Zahn ZSDK-R	*						550 ²⁾	550 ³⁾	
Zahn ZTSD	*						550 ²⁾	550 ³⁾	
Zahn ZGBK-E	ZLVT 0008 ZLVT 0012							550 ³⁾	
Zahn ZK GK-E/R	*							550 ³⁾	
Zahn ZBST	ZLVT 0008 ZLVT 0012						550 ²⁾		
Zahn ZBSK-R	*						550 ²⁾		

* Combination of fastener and dowel with washer

Timber

- 1 structural timber EN 338/C24, $t \geq 22$ mm, effective embedment depth ≥ 22 mm
- 2 polywood BFU 100 EN 636, $t \geq 19$ mm, effective embedment depth ≥ 19 mm
- 3 OSB3 EN 300, $t \geq 18$ mm, effective embedment depth ≥ 18 mm
- 4 particle board EN 312/P5, $t \geq 19$ mm, effective embedment depth ≥ 19 mm

Concrete and aerated concrete

- ¹⁾ effective anchorage depth ≥ 30 mm
- ²⁾ effective anchorage depth ≥ 40 mm
- ³⁾ effective anchorage depth ≥ 60 mm
- ⁴⁾ effective anchorage depth ≥ 25 mm
- ⁵⁾ effective anchorage depth ≥ 32 mm
- ⁶⁾ effective anchorage depth ≥ 35 mm

Sheet Deck

- 1 Steel S280GD – EN 10326, $t \geq 0,75$ mm
- 2 Steel S280GD – EN 10326, $t \geq 1,0$ mm

Henkel KGaA
 Bautechnik/Wolfin
 Am Rosengarten 5
 63607 Wächtersbach-Neudorf
 Germany

Wolfin Bautechnik Bahnsysteme
 (ETAG 006)
Admissible load per fastener

Annex 6.2
 Mechanically fastened
 roof waterproofing system
 European technical approval
 N° ETA-09/0204
 dated 7 December 2009

DEUTSCHES INSTITUT FÜR BAUTECHNIK

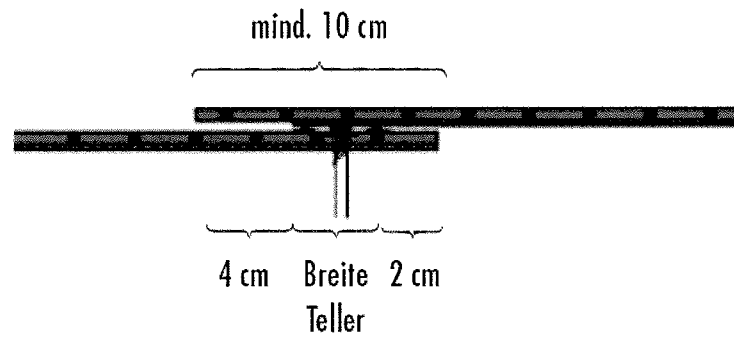

Fig.1: Fixing in overlapping area in longitudinal direction
Distance between border of the washer and the edge of the underlay sheet at least 20 mm

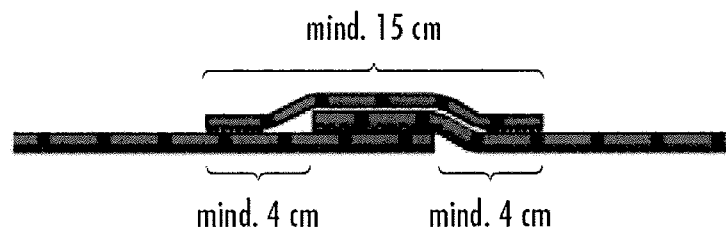

Fig. 2: Minimum overlapping in cross-seam- / headerarea

Henkel KGaA
Bautechnik/Wolfin
Am Rosengarten 5
63607 Wächtersbach-Neudorf
Germany

Wolfin Bautechnik Bahnsysteme
(ETAG 006)
Overlapping fixation

Annex 7
Mechanically fastened
roof waterproofing system

European technical approval
N° ETA-09/0204
dated 7 December 2009

DEUTSCHES INSTITUT FÜR BAUTECHNIK

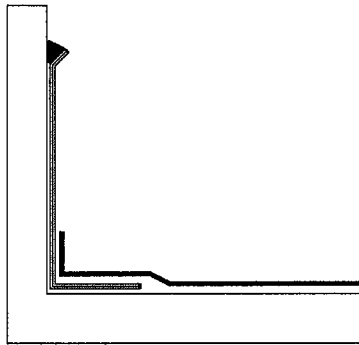

Fig. 3: Connection and corner with a metal sheet profile

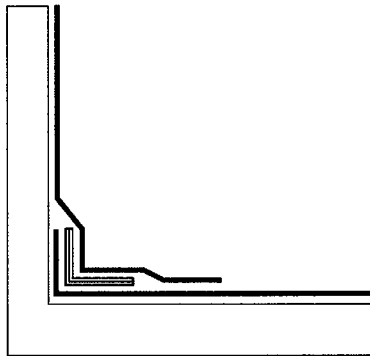

Fig. 4: Connection and corner with a fixed (glued) sheet

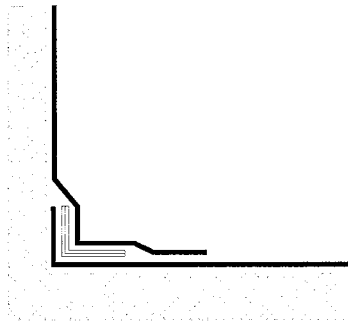

Fig. 5: Connection and corner with a loose laid sheet

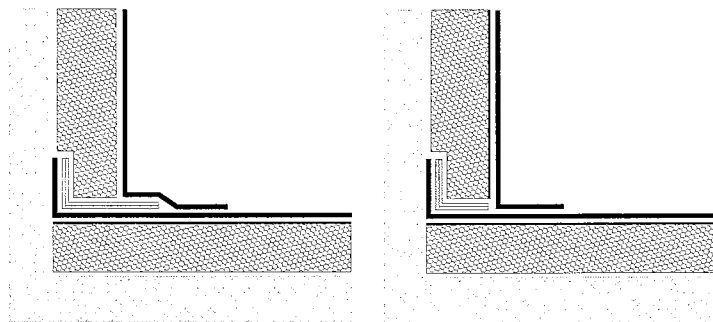

Fig. 6: Connection and corner for insulated components with a loose laid sheet (figure on the left) or with a fixed (glued) sheet (figure on the right)

Henkel KGaA
Bautechnik/Wolfin
Am Rosengarten 5
63607 Wächtersbach-Neudorf
Germany

Wolfin Bautechnik Bahnsysteme
(ETAG 006)
Fixing examples

Annex 8
Mechanically fastened
roof waterproofing system

European technical approval
N° ETA-09/0204
dated 7 December 2009

DEUTSCHES INSTITUT FÜR BAUTECHNIK



Fig. 7: Intermediate fixing (vertikal) with profile

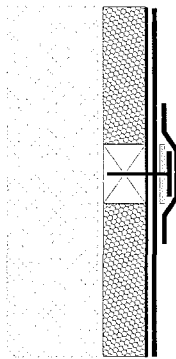

Fig. 8: Intermediate fixing (vertikal) for insulated components with wood and profile

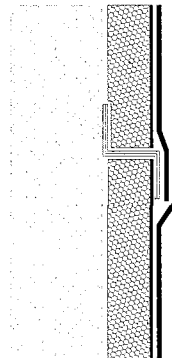

Fig. 9: Intermediate fixing (vertikal) for insulated components with metal profile (Z-Profile)

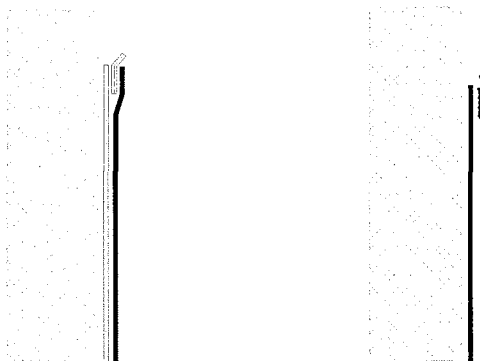

Fig. 10: Wall fastening with with metal profiles

<p>Henkel KGaA Bautechnik/Wolfin Am Rosengarten 5 63607 Wächtersbach-Neudorf Germany</p>	<p>Wolfin Bautechnik Bahnsysteme (ETAG 006) Fixing examples</p>	<p>Annex 9 Mechanically fastened roof waterproofing system</p> <p>European technical approval N° ETA-09/0204 dated 7 December 2009</p>
---	---	---

DEUTSCHES INSTITUT FÜR BAUTECHNIK

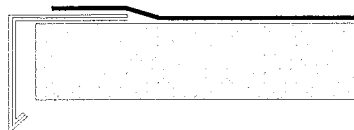

Fig.11: Roof edge with metal profile

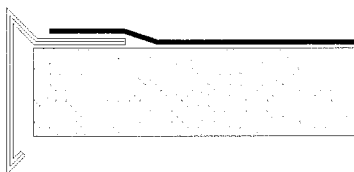

Fig. 12: Roof edge with metal profile

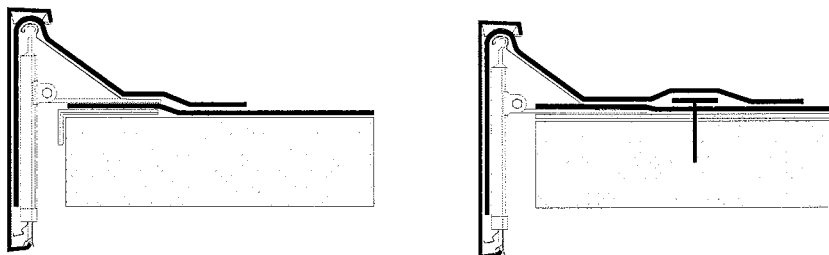

Fig. 13: Roof edge with metal profile

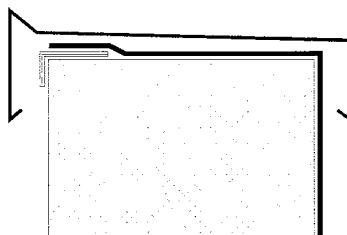

Fig. 14: Wall capping with metal profile

Henkel KGaA
Bautechnik/Wolfin
Am Rosengarten 5
63607 Wächtersbach-Neudorf
Germany

Wolfin Bautechnik Bahnsysteme
(ETAG 006)
Cappings and border profiles

Annex 10
Mechanically fastened
roof waterproofing system

European technical approval
N° ETA-09/0204
dated 7 December 2009

DEUTSCHES INSTITUT FÜR BAUTECHNIK

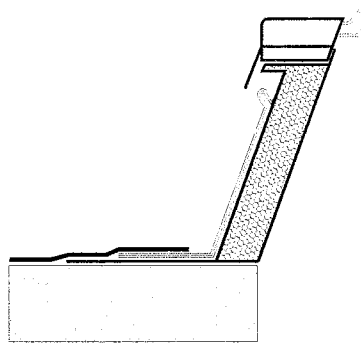

Fig.15: Connection to the dome light with metal profile

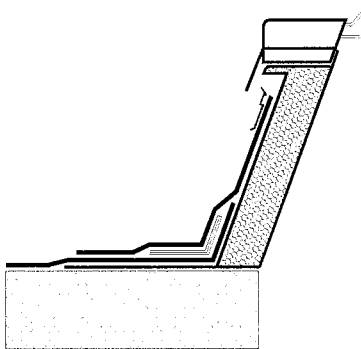

Fig. 16: Connection to the dome light with sheets

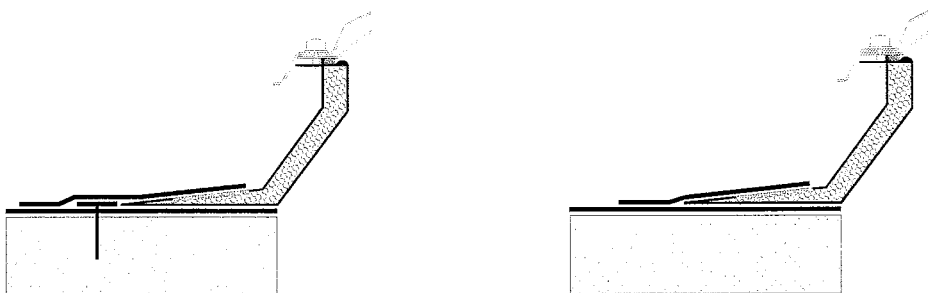

Fig. 17: Connection to the dome light with PVC-frame

Henkel KGaA
Bautechnik/Wolfin
Am Rosengarten 5
63607 Wächtersbach-Neudorf
Germany

Wolfin Bautechnik Bahnsysteme
(ETAG 006)
Dome light

Annex 11
Mechanically fastened
roof waterproofing system

European technical approval
N° ETA-09/0204
dated 7 December 2009

DEUTSCHES INSTITUT FÜR BAUTECHNIK

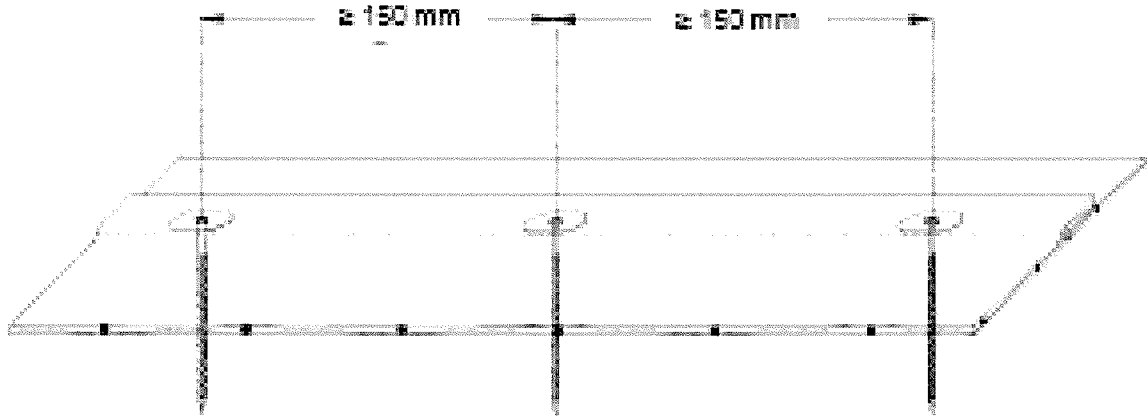

minimum distance between fasteners	$\geq 150 \text{ mm}$
maximum distance between fastener and edge of sheet	$\geq 20 \text{ mm}$
minimum number of fastener	2 piece/m ²

Fig.18: Fastening system claimed and fastener distance

Henkel KGaA
 Bautechnik/Wolfin
 Am Rosengarten 5
 63607 Wächtersbach-Neudorf
 Germany

Wolfin Bautechnik Bahnsysteme
 (ETAG 006)
Distance for Fastening

Annex 12
 Mechanically fastened
 roof waterproofing system
 European technical approval
 N° ETA-09/0204
 dated 7 December 2009