

Deutsches Institut für Bautechnik

Anstalt des öffentlichen Rechts

Kolonnenstr. 30 L
10829 Berlin
Germany

Tel.: +49(0)30 787 30 0
Fax: +49(0)30 787 30 320
E-mail: dibt@dibt.de
Internet: www.dibt.de

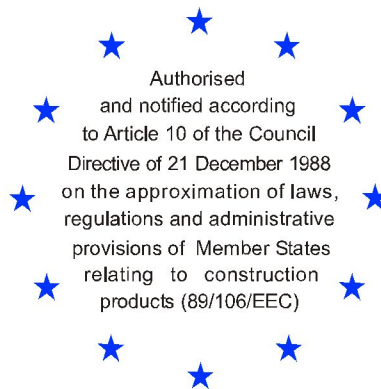

DIBt

Mitglied der EOTA
Member of EOTA

European Technical Approval ETA-05/0170

English translation prepared by DIBt - Original version in German language

Handelsbezeichnung
Trade name

ARGISOL

Zulassungsinhaber
Holder of approval

BEWA GmbH
ARGISOL-Bausysteme
Grünstadter Straße 2
67271 Obersülzen

Zulassungsgegenstand
und Verwendungszweck
Generic type and use
of construction product

Nicht lasttragender verlorener Schalungsbausatz "ARGISOL"
aus EPS Schalungselementen
Non load bearing shuttering kit "ARGISOL"
based on shuttering elements of EPS

Geltungsdauer: vom
Validity: from
bis
to

24 March 2010
15 November 2010

Herstellwerk
Manufacturing plant

BEWA GmbH
ARGISOL-Bausysteme
Grünstadter Straße 2a
67271 Obersülzen
DEUTSCHLAND

Diese Zulassung umfasst
This Approval contains

29 Seiten einschließlich 12 Anhänge (mit 16 Seiten)
29 pages including 12 annexes (with 16 pages)

Diese Zulassung ersetzt
This Approval replaces

ETA-05/0170 mit Geltungsdauer vom 16.11.2005 bis 15.11.2010
ETA-05/0170 with validity from 16.11.2005 to 15.11.2010



Europäische Organisation für Technische Zulassungen
European Organisation for Technical Approvals

I LEGAL BASES AND GENERAL CONDITIONS

- 1 This European technical approval is issued by Deutsches Institut für Bautechnik in accordance with:
 - Council Directive 89/106/EEC of 21 December 1988 on the approximation of laws, regulations and administrative provisions of Member States relating to construction products¹, modified by Council Directive 93/68/EEC² and Regulation (EC) N° 1882/2003 of the European Parliament and of the Council³;
 - Gesetz über das In-Verkehr-Bringen von und den freien Warenverkehr mit Bauprodukten zur Umsetzung der Richtlinie 89/106/EWG des Rates vom 21. Dezember 1988 zur Angleichung der Rechts- und Verwaltungsvorschriften der Mitgliedstaaten über Bauprodukte und anderer Rechtsakte der Europäischen Gemeinschaften (Bauproduktengesetz - BauPG) vom 28. April 1998⁴, as amended by law of 31 October 2006⁵;
 - Common Procedural Rules for Requesting, Preparing and the Granting of European technical approvals set out in the Annex to Commission Decision 94/23/EC⁶;
 - Guideline for European technical approval of "Nonload-bearing permanent shuttering systems based on hollow blocks or panels of insulating materials and sometimes concrete", ETAG 009.
- 2 Deutsches Institut für Bautechnik is authorized to check whether the provisions of this European technical approval are met. Checking may take place in the manufacturing plant. Nevertheless, the responsibility for the conformity of the products to the European technical approval and for their fitness for the intended use remains with the holder of the European technical approval.
- 3 This European technical approval is not to be transferred to manufacturers or agents of manufacturers other than those indicated on page 1, or manufacturing plants other than those indicated on page 1 of this European technical approval.
- 4 This European technical approval may be withdrawn by Deutsches Institut für Bautechnik, in particular pursuant to information by the Commission according to Article 5(1) of Council Directive 89/106/EEC.
- 5 Reproduction of this European technical approval including transmission by electronic means shall be in full. However, partial reproduction can be made with the written consent of Deutsches Institut für Bautechnik. In this case partial reproduction has to be designated as such. Texts and drawings of advertising brochures shall not contradict or misuse the European technical approval.
- 6 The European technical approval is issued by the approval body in its official language. This version corresponds fully to the version circulated within EOTA. Translations into other languages have to be designated as such.

1 Official Journal of the European Communities L 40, 11 February 1989, p. 12
2 Official Journal of the European Communities L 220, 30 August 1993, p. 1
3 Official Journal of the European Union L 284, 31 October 2003, p. 25
4 Bundesgesetzblatt Teil I 1998, p. 812
5 Bundesgesetzblatt Teil I 2006, p. 2407, 2416
6 Official Journal of the European Communities L 17, 20 January 1994, p. 34

II SPECIFIC CONDITIONS OF THE EUROPEAN TECHNICAL APPROVAL

1 Definition of product and intended use

1.1 Definition of construction product

The shuttering system "ARGISOL" is a non-load-bearing permanent shuttering kit based on shuttering elements and accessory parts (see Annexes 1 to 5 and 9 to 12) applicable as formwork for plain and reinforced concrete walls cast in-situ. The accessory parts are wedges for horizontal curved walls, floor end plates, single plates, pieces for the equalization of differences in height and end stops.

1.1.1 Shuttering elements

The shuttering elements consist of one-layered expanded polystyrene (EPS) leaves which are prefabricated in connection with spacers of steel. The spacers of steel are 0.63 mm thick and connect the shuttering leaves. The distance between the spacers in longitudinal direction of the elements is 125 mm (see Annexes 1 and 9). The two ends of the spacers are embedded in the EPS (expanded polystyrene) of the shuttering leaves.

The upper and lower surfaces of the shuttering leaves are castellated. The vertical mating surfaces are tongue and groove to form a tight fit when joined together. The outer and inner surfaces have tapered grooves running vertically. In the inner surfaces the grooves ribs serve as mechanical fixing of the shuttering leaves to the concrete. They also form locks for end stops. The length of the elements is 1000 mm respectively 1250 mm and the height is 250 mm, see Annexes 1.1 and 1.2.

The thickness of the inner shuttering leaf is for all elements 52 mm and the thickness of the outer shuttering leaf is either 55 mm or 65 mm respectively 155 mm. The minimum thickness of the concrete core is 133 mm respectively 143 mm.

Special elements are also part of the kit as corner elements (see Annexes 2 and 10), angular elements (Annexes 3 and 10), T-elements (Annexes 4 and 11), elements with hinges for horizontal curved walls (Annex 5) and lintel elements (Annexes 3 and 12) which are produced in the same manner as described above.

1.1.2 Accessory parts

1.1.2.1 Wedges for horizontal curved walls (Annex 5)

Are as high as the shuttering leaves (250 mm) and are used to fill the gaps between the vertical joints on the inner side of the horizontal curved walls made with the elements given in Annex 5.

1.1.2.2 Floor end plates (Annex 3)

It is used for the vertical shuttering of the floor plates and to avoid heat bridges in the floor levels in end use conditions. The upper and lower surfaces are castellated in the same way as for the shuttering leaves of the elements. Their vertical mating surfaces are tongue and groove and form a tight fit when they are put together. They are 100 mm thick and 200 mm high. At the inside of the plates there are pockets which, together with the walls, are filled with concrete and reinforcement. After hardening of the concrete of the wall the floor end plates are sufficiently fixed to resist the concrete pressure when concreting the floors.

1.1.2.3 Single plates, pieces for the equalization of differences in height and end stops (Annexes 5 and 9)

The upper and lower surfaces of all these parts are castellated in the same way as for the shuttering leaves of the elements. The structure of the inner and outer surface is the same as for the shuttering leaves. Their vertical mating surfaces are tongue and groove and form a tight fit when put together.

Single plates and pieces for equalization are used to fill gaps, which are not possible to fill with shuttering elements (e.g. joints to the roof). Single plates have the same dimensions as the shuttering leaves, pieces for the equalization of differences in height are 50 mm thick and high and 133 mm respectively 143 mm long.

End stops are 50 mm thick and 133 mm respectively 143 mm long. They are inserted in the gaps between the shuttering leaves at the openings of the wall.

1.2 Intended use

The kit is intended to be used for construction of internal walls as well as external walls above or below ground which are load-bearing (structural) or non-load-bearing (non structural), including those which are subjected to fire regulations.

When using this type of construction below ground a waterproofing according to applicable national rules shall be provided depending on whether water not exerting pressure or water exerting pressure is to be dealt with. The waterproofing shall be protected from mechanical damage by a smash-resistant protective layer.

The provisions made in this European technical approval are based on an assumed working life of the shuttering kit in end use condition of at least 50 years, provided that the conditions laid down in sections 4.2, 5.1 and 5.2 for installation, packaging, transport, storage, use, maintenance and repair are met. The indications given on the working life cannot be interpreted as a guarantee given by the producer, but are to be regarded only as a means for choosing the right products in relation to the expected economically reasonable working life of the works.

2 Characteristics of products and methods of verification

2.1 Characteristics of products

2.1.1 Shuttering elements

The standard and special shuttering elements as well as the accessory parts correspond to the information and drawings given in Annexes 1 to 5 and 9 to 12. The kit consists of the following shuttering elements, plates and pieces:

- standard shuttering elements (Annexes 1 and 9)
- corner shuttering elements (Annexes 2 and 10)
- angular shuttering elements (Annexes 3 and 10)
- T-elements (Annexes 4 and 11)
- Elements with hinges for horizontal curved walls (Annex 5)
- Lintel elements (Annexes 3 and 12)

For the shuttering leaves expanded polystyrene

EPS-EN 13163-T1-L1-W2-S2-P4-DS(70,-)3-BS250-DS(N)5-TR100 CS(10)150 made of polystyrene particle foam with a apparent density of 29 to 31 kg/m³ respectively a thermal conductivity $\lambda_d = 0,031 \text{ W/(m}\cdot\text{k)}$ according to EN 13163 is used.

The spacers of steel (see e.g. Annexes 1 and 9) have a minimum overall thickness of 0,60 mm and a minimum height in the middle of spacer of 50 mm. The spacers of steel are galvanized and consist of a minimum tensile strength of 360 MPa.

The material characteristics, dimensions and tolerances of the shuttering elements not indicated in Annexes 1 to 5 and 9 to 12 are given in the technical documentation⁷ of the ETA.

The shuttering element allows for plain and reinforced concrete wall with a concrete core thickness of 133 mm or 143 mm. Table 1 shows the possible wall thicknesses.

Table 1: Wall thickness

No	Internal leaf of EPS [mm]	External leaf of EPS [mm]	Concrete core (wall cavity core) [mm]	Overall wall width [mm]	according ETA-Annex for standard elements
1	52	65	133	250	1
2	52	55	143	250	9.1
3	52	155	143	350	9.2

2.1.2 Accessory parts

Wedges for horizontal curved walls (Annex 5), floor end plates (Annex 3), single plates, end stops and pieces for the equalization of differences in height (Annexes 5 and 9) are made of the same EPS material as the shuttering leaves.

2.2 Methods of verification

2.2.1 General

The assessment of the fitness of the shuttering system for the intended use has been made in compliance with ETAG 009, Guideline for European Technical Approval of "Non-load-bearing permanent shuttering kits/systems based on shuttering elements or blocks of insulating materials and sometimes concrete", edition June 2002.

The ETA is issued for the shuttering kit "ARGISOL" on the basis of agreed information, deposited with Deutsches Institut für Bautechnik (DIBt), which identifies the shuttering kit that has been assessed and evaluated. Changes to the production process, the kit or the components which could result in this deposited information being incorrect, shall be notified to DIBt before the changes are introduced. DIBt will decide whether or not such changes affect the ETA and consequently the validity of the CE marking on the basis of the ETA, and, if so, whether further assessment and/or alterations to the ETA shall be necessary.

2.2.2 Essential Requirement 1: Mechanical resistance and stability

2.2.2.1 Resulting structural pattern

In end use conditions walls made with shuttering elements "ARGISOL" are walls of a continuous type according to ETAG 009, paragraph 2.2.

2.2.2.2 Efficiency of filling

Considering the instructions of chapter 4.2 and the installation guide of the ETA applicant the efficient filling without bursting of the shuttering and without voids or any uncovered reinforcement in the concrete core is possible.

The requirements according to ETAG 009, chapter 6.1.2 are met satisfactorily.

⁷ The technical documentation of the ETA is deposited with DIBt and, as far as relevant for the tasks of the approved bodies involved in the attestation of conformity procedure, is handed over to the approved bodies.

2.2.2.3 Possibility of steel reinforcement

The instructions in the installation guide of the ETA applicant are appropriate to install steel reinforcement for walls according to EN 1992-1-1 or corresponding national rules.

The requirements according to ETAG 009, chapter 6.1.3 are met satisfactorily.

2.2.3 Essential Requirement 2: Safety in case of fire

2.2.3.1 Reaction to fire

Class E according to EN 13501-1⁸

2.2.3.2 Resistance to fire

With the minimum thickness of the continuous concrete core of 133 mm the fire resistance class of walls with a minimum concrete strength C16/20 according to Table 1 of Annex C of ETAG 009 is REI 90.

2.2.4 Essential Requirement: 3 Hygiene, health and the environment

2.2.4.1 Release of dangerous substances

According to the manufacturer's declaration the shuttering elements "ARGISOL" taking account of the EU database⁹ do not contain any dangerous substances.¹⁰

2.2.4.2 Water vapour permeability

The tabulated design value of the water vapour diffusion resistance coefficient of expanded polystyrene (EPS) according to EN 12524¹¹ is $\mu = 60$.

The values for the water vapour diffusion resistance of concrete depending on density and type are tabulated in EN 12524.

2.2.5 Essential Requirement 4: Safety in use

2.2.5.1 Bond strength between the shuttering leaves and the concrete core

The expanded polystyrene is bonded to the concrete by mechanical interlocking of the dovetail sections running vertically in the inner surfaces of the shuttering leaves over the whole height of the element with a horizontal distance of 2,4 cm (i.e. 41 sections per meter length). Since the minimum width of the dovetail sections is 10 mm the effective area for the transmission of tensile forces is $0,01 \cdot 1 \cdot 41 \text{ m}^2 = 0,41 \text{ m}^2$. This is more than 20 % of the whole area of the shuttering leaves and leads to the effective bond strength of $0,041 \text{ N/mm}^2$ which is sufficient to meet the requirements of ETAG 004, chapter 6.1.4.1.3 .

The requirements according to ETAG 009, chapter 6.4.1.3 are met satisfactorily.

⁸ A European reference fire scenario for facades has not been laid down. In some Member States the classification of permanent shuttering systems according to EN 13501-1:2002 might not be sufficient for the use in facades. An additional assessment of permanent shuttering systems according to national provisions (e.g. on the basis of a large scale test) might be necessary to comply with Member States regulations, until the existing European classification system has been completed.

⁹ Notes are stated in Guidance Paper H: "A harmonized approach relating to dangerous substances under the Construction Products Directive", Brussels, 18 February 2000

¹⁰ In addition to the specific clauses relating to dangerous substances contained in this European Technical Approval, there may be other requirements applicable to the products falling within its scope (e.g. transposed European legislation and national laws, regulations and administrative provisions). In order to meet the provisions of the EC Construction Products Directive, these requirements need also to be complied with, when and where they apply.

¹¹ EN 12524:2000 Building materials and products - Hygrothermal properties - Tabulated design values

2.2.5.2 Resistance to filling pressure

To resist the filling pressure the bending tensile strength of the shuttering leaves shall be more than 250 kPa (see also designation code of EPS in 2.1.1) and the strength to pull out of the spacers more than 850 N.

The requirements according to ETAG 009, chapter 6.4.2 are met satisfactorily.

2.2.5.3 Safety against personal injury by contact

Delivered on site the shuttering elements do not have sharp or cutting edges.

Because of the soft surface of the shuttering leaves there is no risk of abrasion or of cutting people.

The requirements according to ETAG 009, chapter 6.4.3 are met satisfactorily.

2.2.6 Essential Requirement 5: Protection against noise

2.2.6.1 Airborne sound insulation

The "No performance determined" option in ETAG 009, Table 3 is used.

2.2.6.2 Sound absorption

The "No performance determined" option in ETAG 009, Table 3 is used.

2.2.7 Essential Requirement 6: Energy economy and heat retention

2.2.7.1 Thermal resistance

Assuming a minimal declared (nominal) value of thermal conductivity of 0.031 W/(m·K) for the expanded polystyrene and for concrete infill of 1,65 W/(m·K) (according to EN 12524¹¹) the shuttering elements according to Table 2 has been determined by numerical calculations taking the influence of the steel spacers into account. Table 2 gives the declared values of thermal resistance R and for information the so called "Overall reduction factor" to determine the influence of the steel spacers on the thermal resistance R.

Table 2: Declared values of thermal resistance R calculated by finite differences¹² (with concrete infill without rendering but with influence of steel spacers) depending on the thickness of the outer layer of expanded polystyrene and thickness of concrete core and the "Overall reduction factor" for information

Type of shuttering element according to ETA, table 1	Thickness of the internal shuttering leaf	Concrete core	Thickness of the external shuttering leaf	Total wall thickness	Overall reduction factor	Declared value of thermal resistance R
[1]	[mm]	[mm]	[mm]	[mm]	[1]	[(m ² ·K)/W]
1)	52	133	65	250	0.80	3.07
2)	52	143	55	250	0.80	2.82
3)	52	143	155	350	0,90	6.06

¹² DIN EN ISO 10211:2008-04 Wärmebrücken im Hochbau - Wärmeströme und Oberflächentemperaturen - Detaillierte Berechnungen (ISO 10211:2007); Deutsche Fassung EN ISO 10211:2007

The planner shall consider accessory parts made of steel as thermal bridges, where relevant, for determination of the thermal resistance.

2.2.7.2 Thermal inertia

The values for the heat capacity of concrete and expanded polystyrene are tabulated in EN 12524.

2.2.8 Aspects of durability and serviceability

2.2.8.1 Resistance to deterioration

Physical agent

As given in the designation code of the EPS material used (see 2.1.1) the dimensions of the shuttering leaves do not differ more than 3 % after exposing them for 48 h at 70 °C (DS(70,-)3).

The requirements according to ETAG 009, chapter 6.7.1.1 are met satisfactorily.

Chemical agent

The spacers made of steel are only necessary for the resistance to concrete pressure. After hardening of the concrete the bond between concrete and shuttering leaves is given by the dovetail sections running vertically on the inner surfaces of shuttering leaves (see 2.2.5.1).

Therefore the requirement "corrosion protection" according to ETAG 009, chapter 6.7.1.2 is met satisfactorily.

Biological agent

The application of EPS as thermal insulating material for decades has shown that it sufficiently protects against fungi, bacteria, algae and insects.

EPS does not provide a food value and in general it does not contain voids suitable for habitation by vermin.

The requirements according to ETAG 009, chapter 6.7.1.3 are met satisfactorily.

2.2.8.2 Resistance to normal use damage

Incorporation of ducts

The instructions in the installation guide of the ETA applicant are appropriate to install horizontally passing ducts on site.

Fixing of objects

Fixing of objects in the shuttering leaves is not possible, the part of fixings which is significant for the mechanical resistance shall be in the concrete core.

3 Evaluation and attestation of conformity and CE marking

3.1 System of attestation of conformity

According to the decision on the procedure of attestation of conformity 98/279/EC of 05 December 1997¹³ amended by the decision 2001/596/EC of the European Commission the system 2+ of the attestation of conformity applies.

¹³ Official Journal of the European Communities L /127 of 24.04.1998

This system of attestation of conformity is defined as follows:

System 2+: Declaration of conformity of the product by the manufacturer on the basis of:

- (a) Tasks for the manufacturer:
 - (1) initial type-testing of the product;
 - (2) factory production control;
 - (3) testing of samples taken at the factory in accordance with a prescribed test plan.
- (b) Tasks for the approved body:
 - (4) certification of factory production control on the basis of:
 - initial inspection of factory and of factory production control;
 - continuous surveillance, assessment and approval of factory production control.

Note: Approved bodies are also referred to as "notified bodies".

3.2 Responsibilities

3.2.1 Tasks for the manufacturer

3.2.1.1 Factory production control

The manufacturer shall exercise permanent internal control of production. All the elements, requirements and provisions adopted by the manufacturer shall be documented in a systematic manner in the form of written policies and procedures, including records of results performed. This production control system shall insure that the product is in conformity with this European technical approval.

The manufacturer may only use raw materials stated in the technical documentation of this European technical approval.

The factory production control shall be in accordance with the "control plan" of 9 March 2010 relating to the European technical approval ETA-05/0170 issued on 24 March 2010 which is part of the technical documentation of this European technical approval. The control plan is laid down in the context of the factory production control system operated by the manufacturer and deposited with Deutsches Institut für Bautechnik.¹⁴

The results of factory production control shall be recorded and evaluated in accordance with the provisions of the control plan.

3.2.1.2 Other tasks for the manufacturer

The manufacturer shall, on the basis of a contract, involve a body which is approved for the tasks referred to in section 3.1 in the field of non-load bearing shuttering systems in order to undertake the actions laid down in section 3.2.2. For this purpose, the control plan referred to in sections 3.2.1.1 and 3.2.2 shall be handed over by the manufacturer to the approved body involved.

The manufacturer shall make a declaration of conformity, stating that the construction product is in conformity with the provisions of the European technical approval ETA-05/0170 issued on 24 March 2010.

3.2.2 Tasks for the approved bodies

The approved body shall perform the

- initial inspection of factory and of factory production control,
 - continuous surveillance, assessment and approval of factory production control,
- in accordance with the provisions laid down in the control plan.

¹⁴ The "control plan" is a confidential part of the European technical approval and only handed over to the approved body involved in the procedure of attestation of conformity. See section 3.2.2.

The the tasks and the frequency of the inspections by the approved bodies shall be performed in accordance with the control plan, part II.

The approved body shall retain the essential points of its actions referred to above and state the results obtained and conclusions drawn in a written report.

The approved certification body involved by the manufacturer shall issue an EC certificate of conformity of the factory production control stating the conformity with the provisions of this European technical approval.

In cases where the provisions of the European technical approval and its control plan are no longer fulfilled the certification body shall withdraw the certificate of conformity and inform Deutsches Institut für Bautechnik without delay.

3.3 CE marking

The CE marking shall be affixed on every second shuttering element and furthermore always on packing and on the accompanying commercial documents. The letters "CE" shall be followed by the identification number of the approved certification body, where relevant, and be accompanied by the following additional information:

- the name and address of the producer (legal entity responsible for the manufacture),
- the last two digits of the year in which the CE marking was affixed,
- the number of the EC certificate for the factory production control,
- the number of the European technical approval ETA-05/0170,
- the number of the guideline ETAG 009 for European technical approval,
- Class E according to EN 13501-1,
- Protection against noise "no performance determined",
- the nominal value of thermal resistance R of the shuttering elements with concrete infill, see ETA.

4 Assumptions under which the fitness of the product for the intended use was favourably assessed

4.1 Manufacturing

The European technical approval is issued for the product on the basis of agreed data/information, deposited with Deutsches Institut für Bautechnik, which identifies the product that has been assessed and judged. Changes to the product or production process, which could result in this deposited data/information being incorrect, should be notified to Deutsches Institut für Bautechnik before the changes are introduced. Deutsches Institut für Bautechnik will decide whether or not such changes affect the approval and consequently the validity of the CE marking on the basis of the approval and if so whether further assessment or alterations to the approval shall be necessary.

4.2 Installation

4.2.1 General

The manufacturer shall ensure that the requirements in accordance with sections 1, 2, and 4 are made known to those involved in planning and execution. The installation guide is deposited with DIBt and shall be present at every construction site. If the manufacturer's instructions contain provisions which differ from those stated here, the specifications of the ETA shall apply.

After installation of the shuttering elements (see 4.2.2) the site-mixed or ready mixed concrete is brought in and compacted.

In end use conditions concrete walls of a continuous type¹⁵ of plain or reinforced concrete will be formed according to EN 1992-1-1 or according to corresponding national rules.

In structural design the thickness of the wall is 133 mm respectively 143 mm and the weight per unit area without rendering 3.40 kN/m² respectively 3.83 kN/m² (assumed density of concrete of 25 kN/m³ and for EPS-leaves of 0,3 kN/m³).

In end use conditions the EPS shuttering leaves are the main part of the thermal insulation of the walls.

4.2.2 Installation of the shuttering elements

The shuttering elements are put together on site in layers without adhesive. To receive stable floor high formworks the vertical joints between two elements of one layer have to be shifted of at least a quarter of the element length to the vertical joints of the previous and next layer (see Annexes 6 and 7).

First of all two layers of the entire floor plan are to be interlocked according to the installation guide of the ETA applicant.

Afterwards leveling to the subsoil is performed (foundation, bottom plate, ceiling). Voids between the shuttering leaves and the uneven subsoil are to be sealed with PU foam before concreting.

Subsequently, according to the installation guide of the ETA applicant, the walls are to be interlocked to floor height, leveled and fastened to the push pull props (see Annex 8).

The push pull props are to be arranged at a maximum distance of 1.20 m to 1.50 m, to be connected over the entire wall height with the shuttering elements and to be fastened to the floor (see Annex 8).

The necessary reinforcement according to structural analysis calculation shall also be installed according to the instructions of the ETA applicant in the installation guide. Rectangular wall corners are to be formed according to Annex 6 and wall junctions according to Annex 7.

4.2.3 Concreting

For the production of normal concrete EN 206-1:2001-07 shall apply. The consistency of concrete on compacting by shaking shall be within the lower consistency range F3 and on compacting by poking within the upper consistency range F3. The maximum aggregate size shall be at least 8 mm and shall not exceed 16 mm. The concrete shall have rapid or middle strength development according to EN 206-1:2001-07, Table 12.

Placing the concrete shall be performed only by persons who were instructed in the works and in the proper handling of the shuttering system.

Placing the concrete shall be performed in layers of 1 m at a maximum vertical concreting rate of 3 m/h. For horizontal curved walls made with shuttering elements according to Annex 5 the vertical concreting rate shall not exceed 1 m/h.

15 see ETAG 009 chapter 2.2

If equivalent national rules are not available the following instructions shall be considered:

Horizontal day joints are to be arranged preferably at the height of the floor. If day joints can not be avoided within the height between the floors vertical composite reinforcement bars shall be installed. The composite reinforcement shall comply the following requirements:

- two adjacent composite reinforcement bars shall not be situated in the same plane parallel to the surface of the wall,
- the distance between two composite reinforcement bars in wall direction shall be at least 10 cm and not larger than 50 cm,
- the total section area of the composite reinforcement bars shall not be less than 1/2000 of the section area of the concrete,
- anchorage length of the composite reinforcement bars on both sides of the day joint at least shall be 20 cm.

Before the further placing of concrete, cement laitance and detached / loose concrete shall be removed and the day joints shall be sufficiently pre-wetted. At the time of concreting the surface of the older concrete shall be slightly moist, so that the cement paste of the newly brought in concrete can combine well with the older concrete.

If no day joint is planned, placing of concrete in layers may only be interrupted until the concrete layer brought in last is not solidified yet so that a good and even bond is still possible between the two concrete layers. When using internal vibrators the vibrating cylinder shall still penetrate into the already compacted lower concrete layer.

The concrete may fall freely only up to a height of 2 m, beyond that the concrete shall be cohered by discharge pipes or concreting tubes with a diameter of 100 mm at the most and shall be led shortly before the place of installation.

Cones from pouring are to be avoided by short distances of the places of fill in.

Planning shall allow for sufficient spaces in the reinforcement for discharge pipes or concreting tubes.

After concreting the walls may not deviate from the plumb line more than 5 mm per running meter wall height.

The ceiling may only be placed on walls made of shuttering elements if the concrete core has reached a sufficient strength.

4.2.4 Ducts crossing and situated inside the wall

Horizontally passing ducts are to be installed according to the installation guide of the ETA applicant and are to be taken into account when designing the wall.

Horizontal ducts situated inside the wall cores are to be avoided. If absolutely necessary, these are to be taken into account when designing the wall.

Also vertical ducts in the concrete core shall be considered, if their diameter exceeds 1/6 of the thickness of the concrete core and the distance of the pipes is less than 2 m.

4.2.5 Reworking and finishes

Walls of the type "ARGISOL" are to be protected by finishes. Finishes are not part of the kit and therefore not considered in this ETA. Preferably for external surfaces the rendering systems used should meet the requirement of ETAG 004¹⁶. The execution of the rendering shall be performed according to applicable national rules.

4.2.6 Fixing of objects

Fixing of objects in the shuttering leaves is not possible, the part of fixings which is significant for the mechanical resistance shall be in the concrete. The influence of the fixing to the reduction of the thermal resistance shall be considered according to EN ISO 6946.

5 Indications on the manufacturer

5.1 Packaging, transport and storage

The shuttering elements shall be protected against damage, soiling and intensive action of water during transport and storage. If necessary the elements shall be covered.

5.2 Use, maintenance, repair

Regular checks should be carried out on render finishes to ensure that any damage is detected and repaired as soon as possible.

The recommendations on use, maintenance and repair in ETAG 009, section 7.5 shall be considered.

Dipl.-Ing. Georg Feistel
Head of Division Construction Engineering
of Deutsches Institut für Bautechnik
Berlin, 24 March 2010

beglaubigt
Deutschmann

Standard elements

100 x 25 x 25

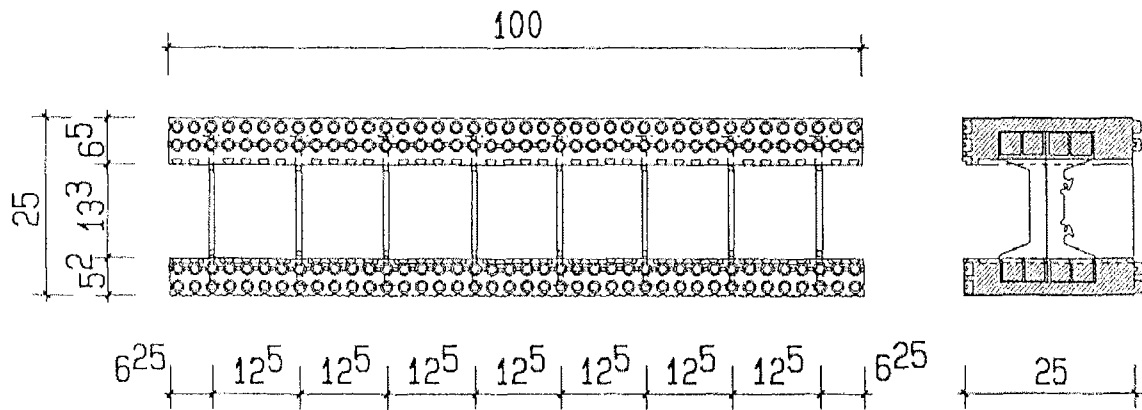

Standard elements with end stops

100 x 25 x 25

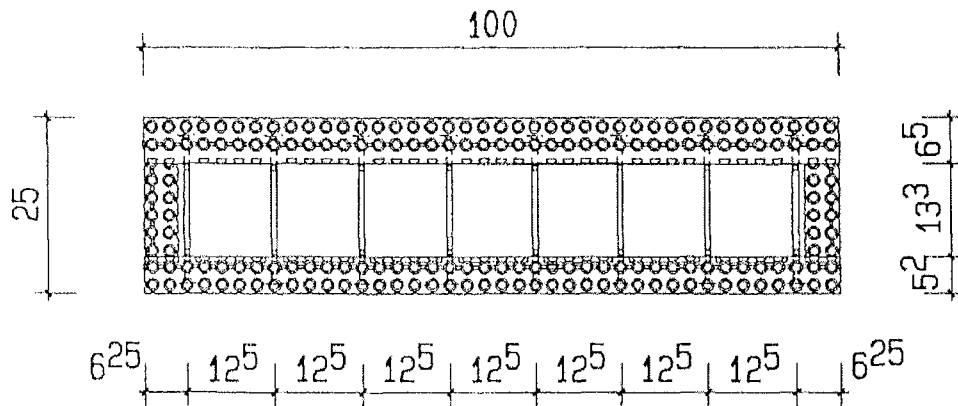

all dimensions in cm

BEWA GmbH
ARGISOL - Bausysteme

Standard shuttering element
Length of element: 100 cm
with concrete core of 13.3 cm
and an overall wall thickness of 25.0 cm

Annex 1.1
of European
Technical Approval

ETA – 05/0170

Standard element - S
1250 x 250 x 250

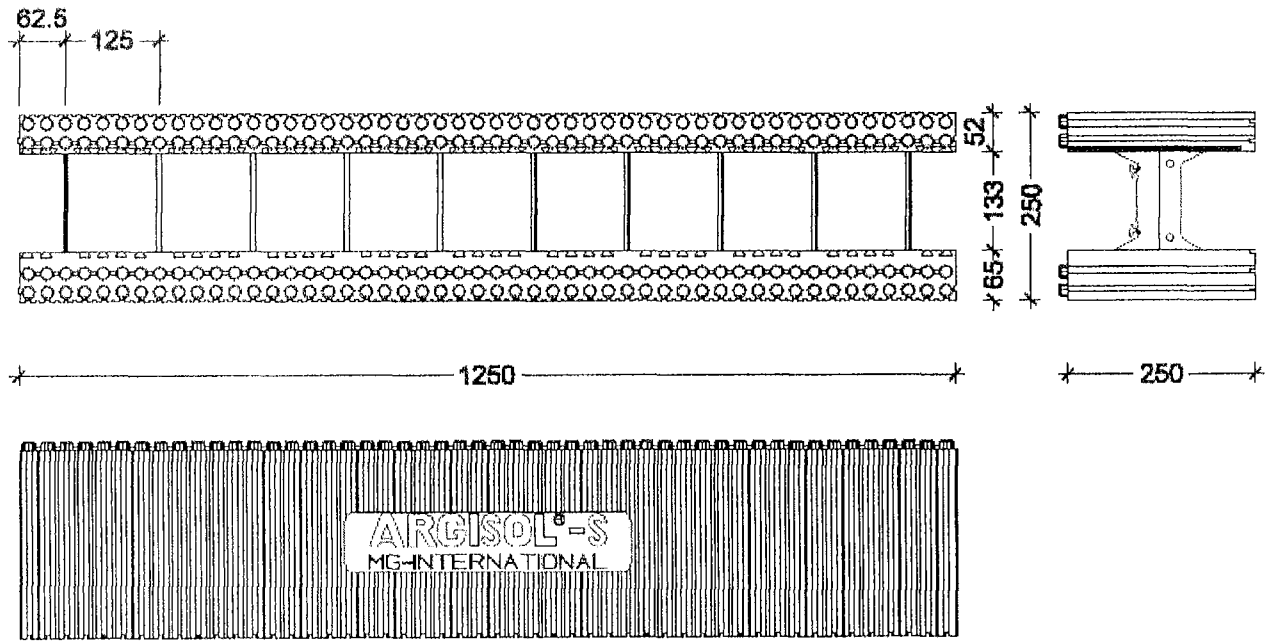

all dimensions in mm

<p align="center">BEWA GmbH ARGISOL - Bausysteme</p>	<p>Annex 1.2 of European Technical Approval</p> <p>ETA – 05/0170</p>
<p align="center">Standard shuttering element S Length of element: 125 cm with concrete core of 13.3 cm and an overall wall thickness of 25.0 cm</p>	

curved corner element
left and right
60 x 35 x 25

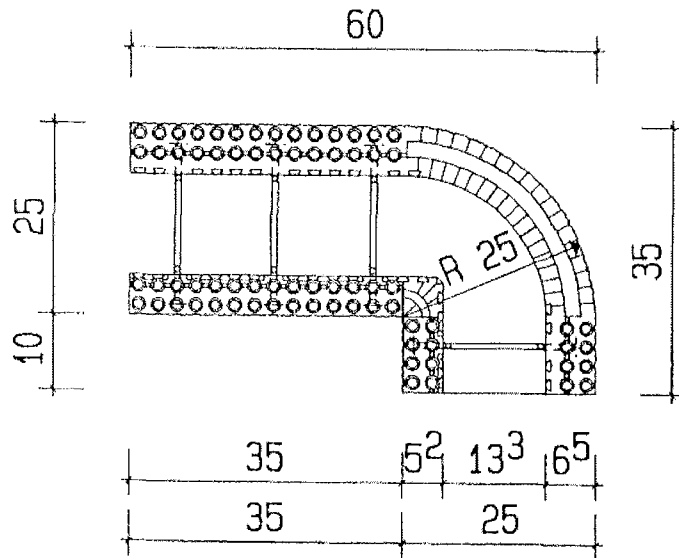

corner element
left and right
60 x 35 x 25

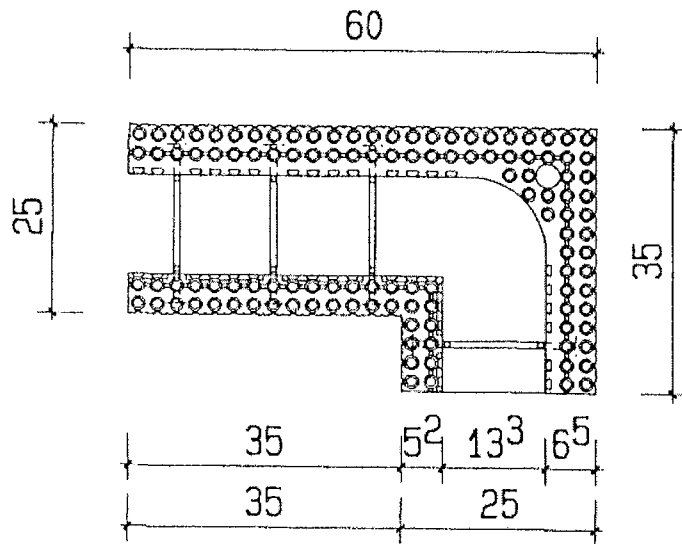

all dimensions in cm

BEWA GmbH
ARGISOL - Bausysteme

Corner elements
with concrete core of 13.3 cm
and an overall wall thickness of 25.0 cm

Annex 2
of European
Technical Approval

ETA – 05/0170

floor end plates

75 x 10 x 20

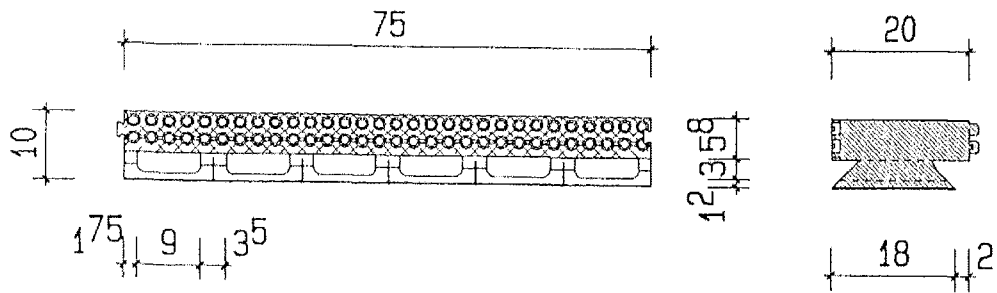

lintel element

75 x 25 x 25

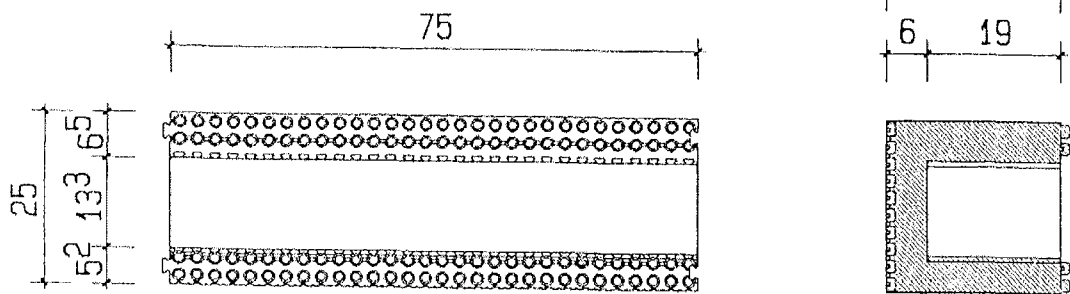

angular element 45°

50 x 25 x 25

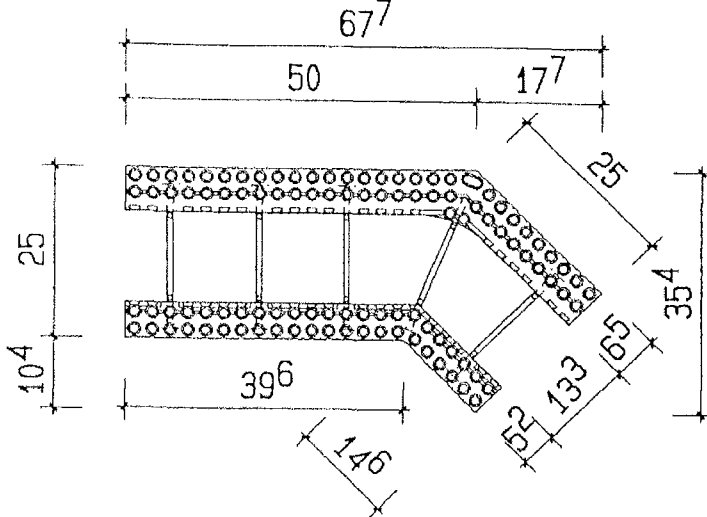

all dimensions in cm

BEWA GmbH
ARGISOL - Bausysteme

Floor end element
Lintel element, angular element
with concrete core of 13.3 cm
and an overall wall thickness of 25.0 cm

Annex 3
European
Technical Approval

ETA – 05/0170

Elements with hinges for horizontal curved walls (top view)

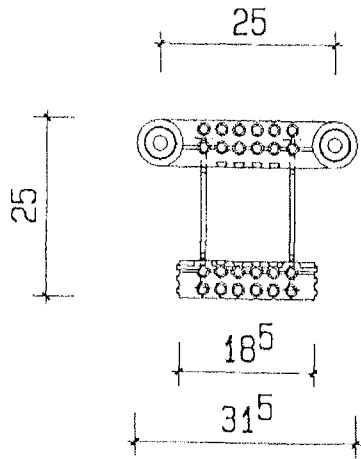

single plates
100 x 25 x 25

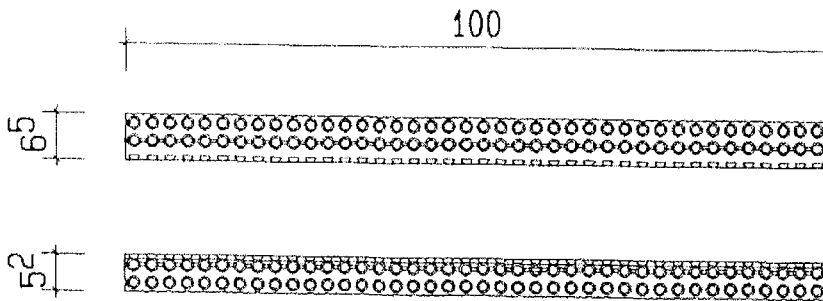

pieces for the equalization of differences in height
50 x 5 x 5

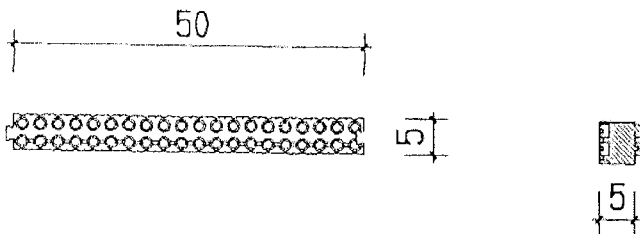

wedges

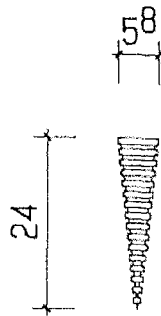

Elements with hinges for horizontal curved walls (elevation)

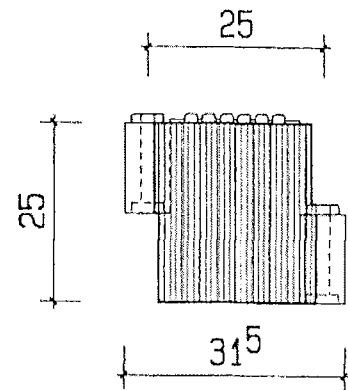

end stops
5 x 14 x 25

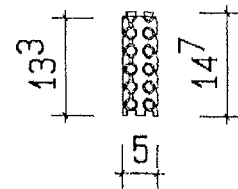

all dimensions in cm

BEWA GmbH
ARGISOL - Bausysteme

Annex 5
of European
Technical Approval

**Elements with hinges and wedges for horizontal curved walls
accessory parts (single plates, end stops, pieces for the
equalization of differences in height)**

ETA - 05/0170

first layer

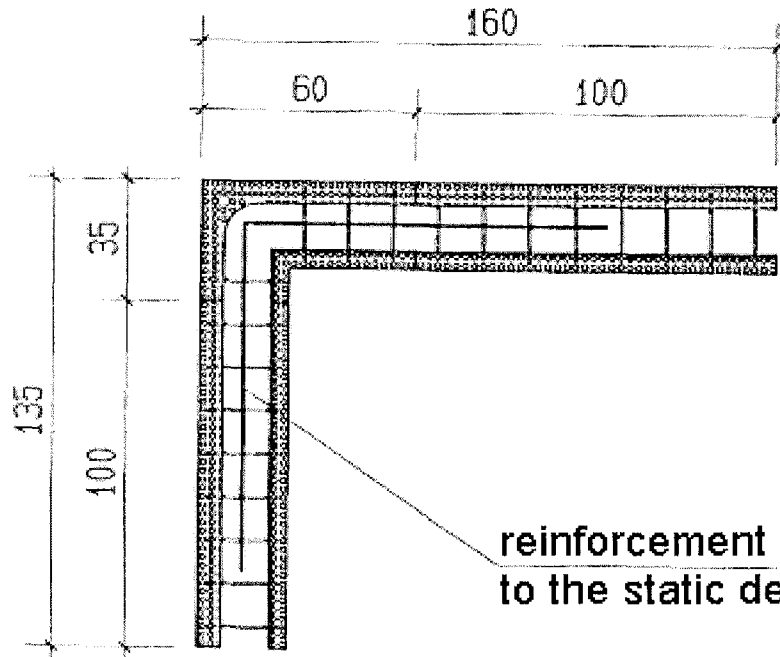

second layer

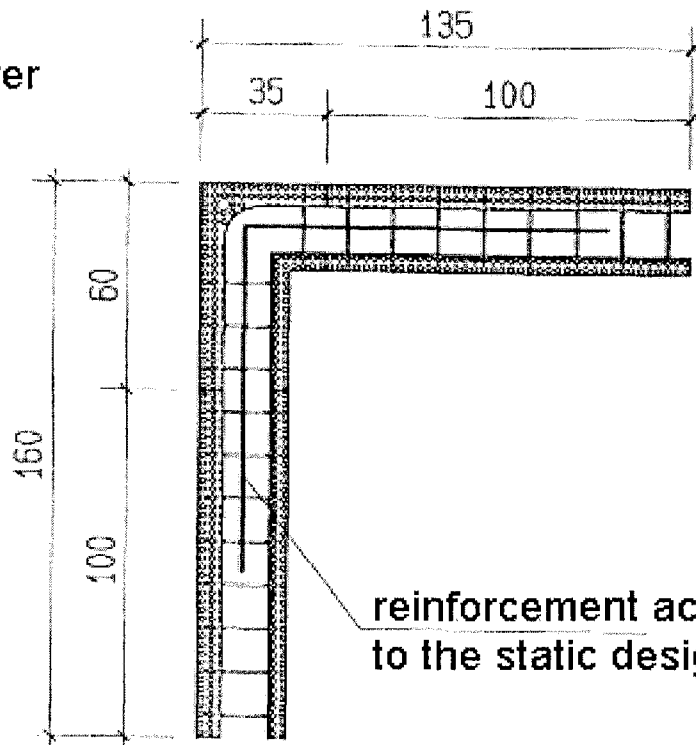

all dimensions in cm

**BEWA GmbH
ARGISOL - Bausysteme**

**Annex 6
of European
Technical Approval**

Bond of different layers on a corner
with concrete core of 13.3 cm
and an overall wall thickness of 25.0 cm

ETA – 05/0170

first layer

reinforcement according to the static design

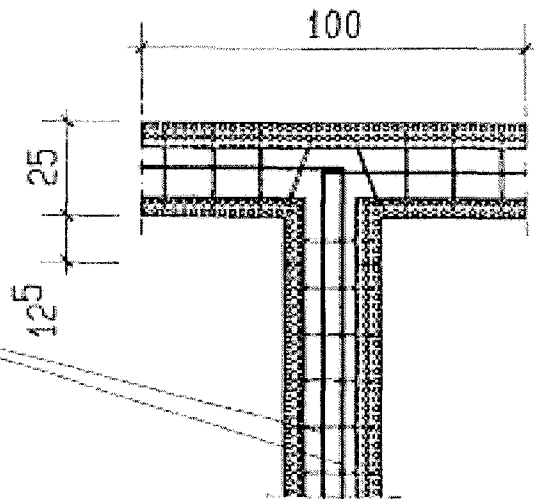

second layer

reinforcement according to the static design

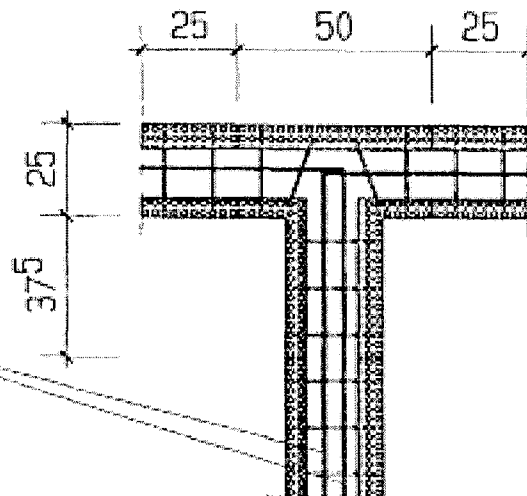

all dimensions in cm

BEWA GmbH
ARGISOL - Bausysteme

Bond of different layers at a wall junction
with concrete core of 13.3 cm
and an overall wall thickness of 25.0 cm

Annex 7
of European
Technical Approval

ETA – 05/0170

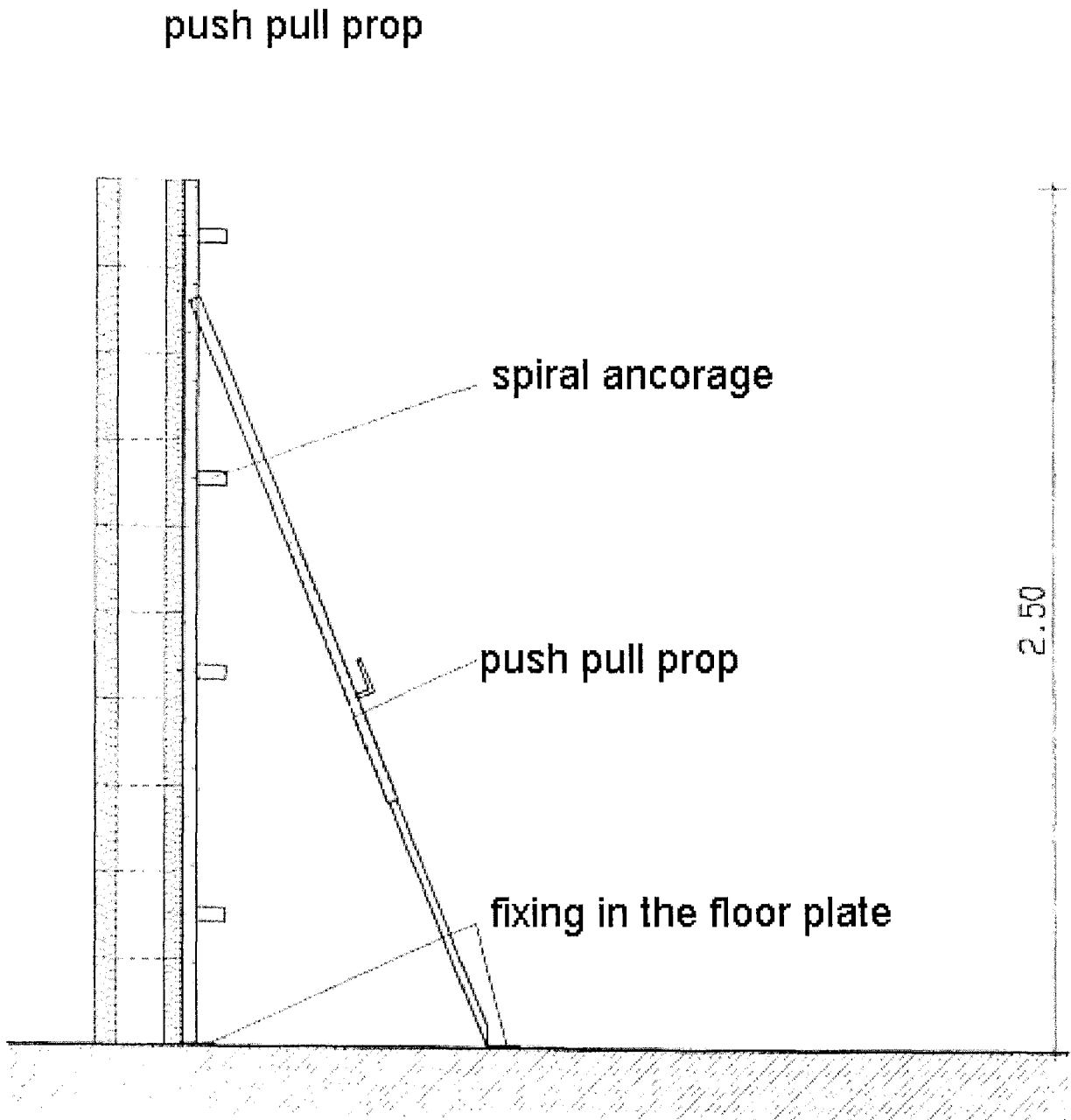

all dimensions in m

BEWA GmbH
ARGISOL - Bausysteme

Scaffolding when placing concrete

Annex 8
of European
Technical Approval

ETA – 05/0170

Standard elements

1000 x 250 x 250

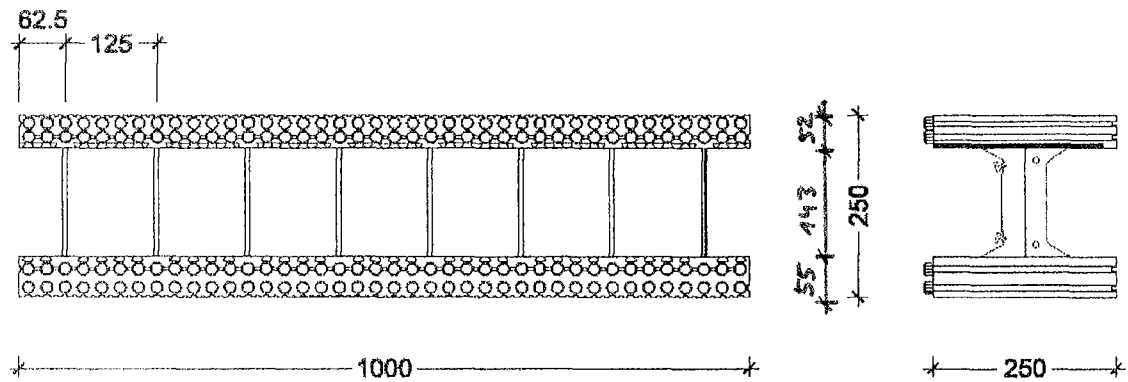

Standard elements with end stop

1000 x 250 x 250

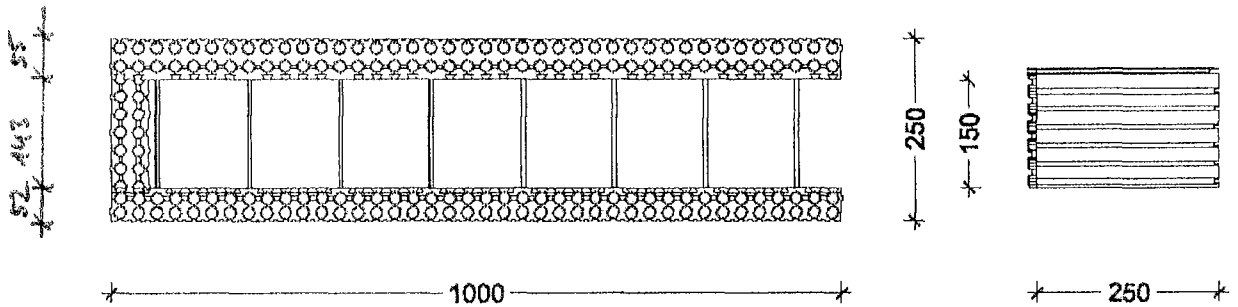

single plates

1000 x 52 x 250

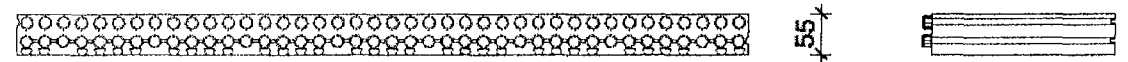
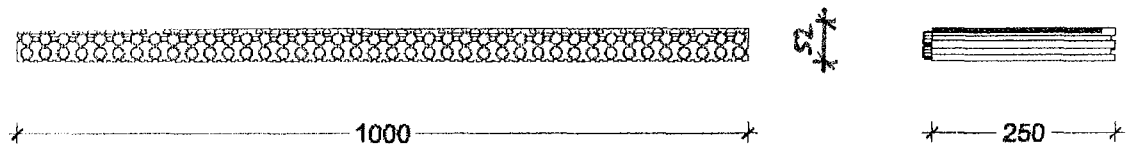

single plates

1000 x 55 x 250

all dimensions in mm

BEWA GmbH
ARGISOL - Bausysteme

Standard shuttering elements
with concrete core of 14.3 cm
and an overall wall thickness of 25.0 cm
Single plates

Annex 9.1
of European
Technical Approval

ETA – 05/0170

Standard element
1000 x 350 x 250 mm

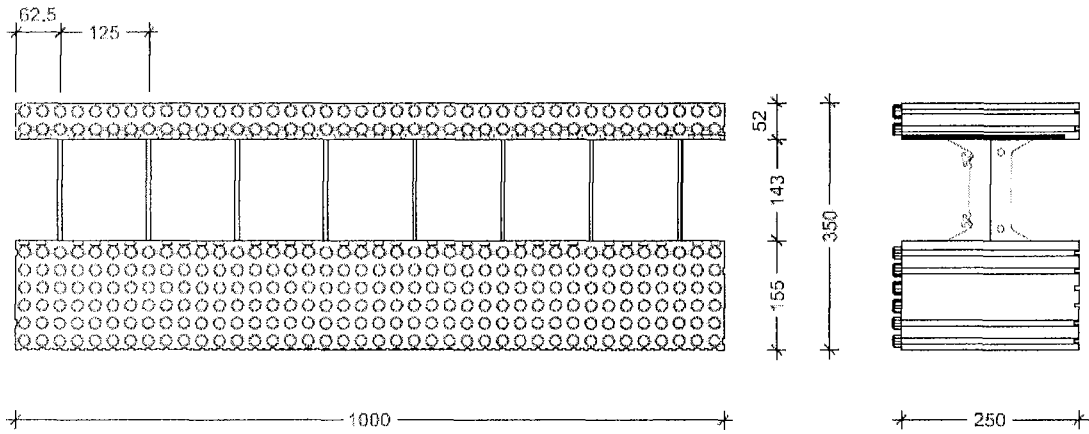

Standard element with end stop
1000 x 350 x 250 mm

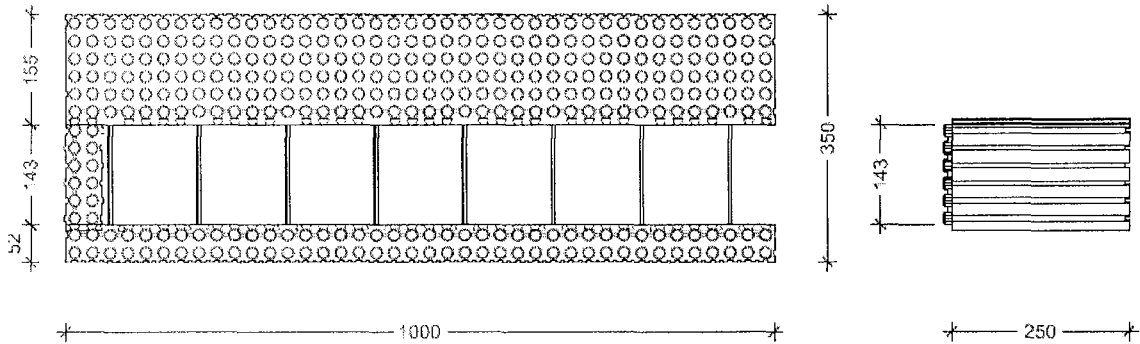

Single board exterior
1000 x 155 x 250 mm

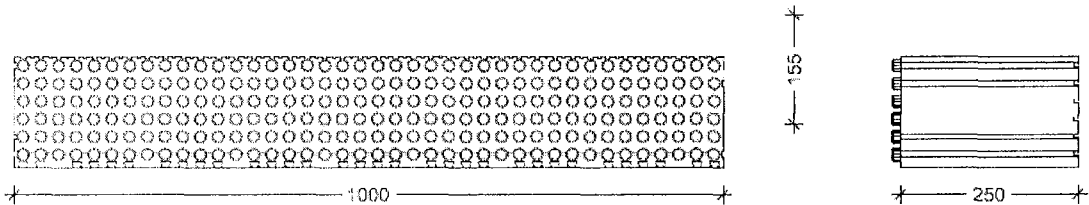

all dimensions in mm

BEWA GmbH
ARGISOL - Bausysteme

Standard shuttering elements
with concrete core of 14.3 cm
and an overall wall thickness of 35.0 cm
Single plates

Annex 9.2
of European
Technical Approval

ETA – 05/0170

corner element left / right
600 x 350 x 250

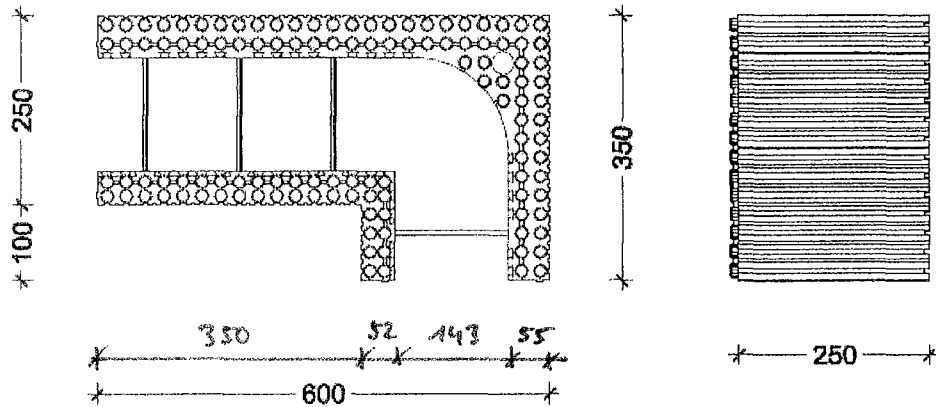

angular element 45°
500 x 250 x 250

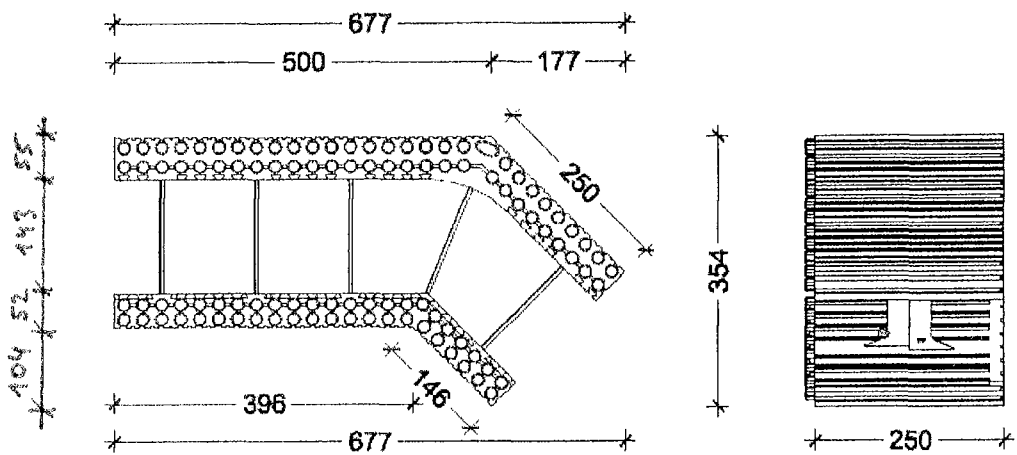

all dimensions in mm

BEWA GmbH
ARGISOL - Bausysteme

Corner and angular elements
 with concrete core of 14.3 cm and
 an overall wall thickness of 25.0 cm

Annex 10.1
 of European
 Technical Approval

ETA – 05/0170

Corner element right / left
700 x 450 x 250 mm

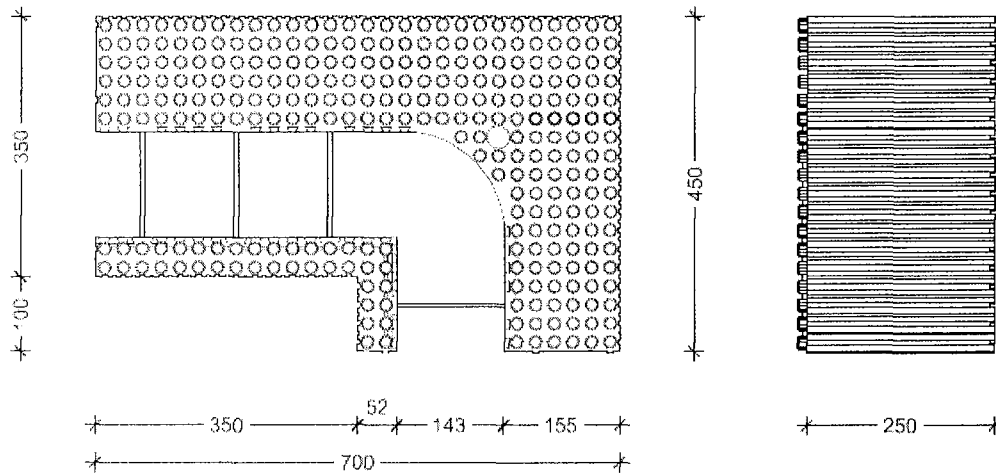

angular elements 45° right / left
747 x 454 x 250 mm

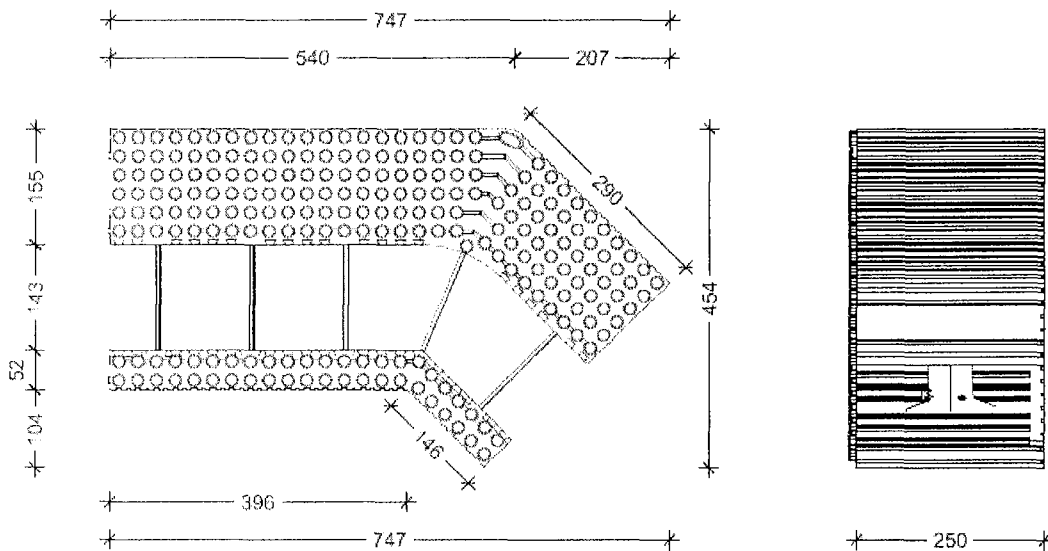

all dimensions in mm

BEWA GmbH
ARGISOL - Bausysteme

Corner and angular elements
with concrete core of 14.3 cm and
an overall wall thickness of 35.0 cm

Annex 10.2
of European
Technical Approval

ETA – 05/0170

Inside corner elements right / left
700 x 450 x 250 mm

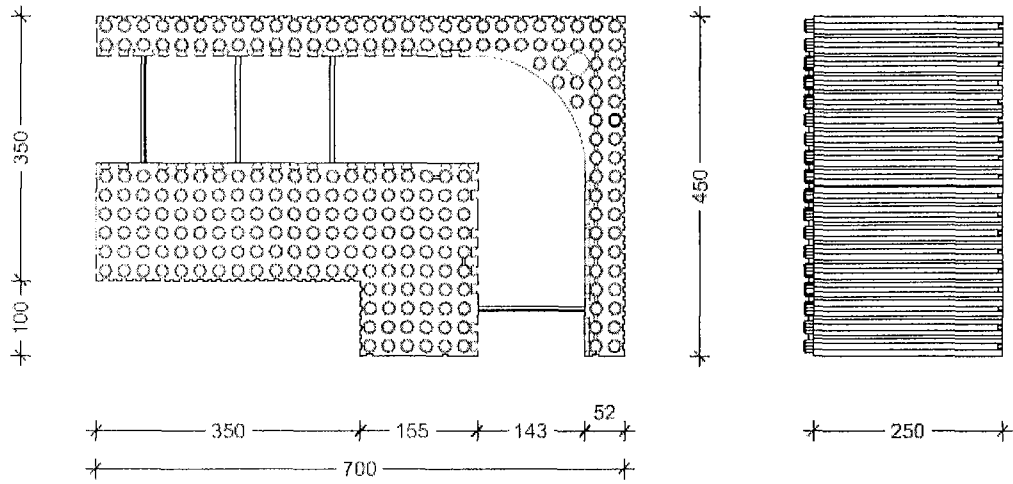

Inside angular elements 45° right / left
747 x 454 x 250 mm

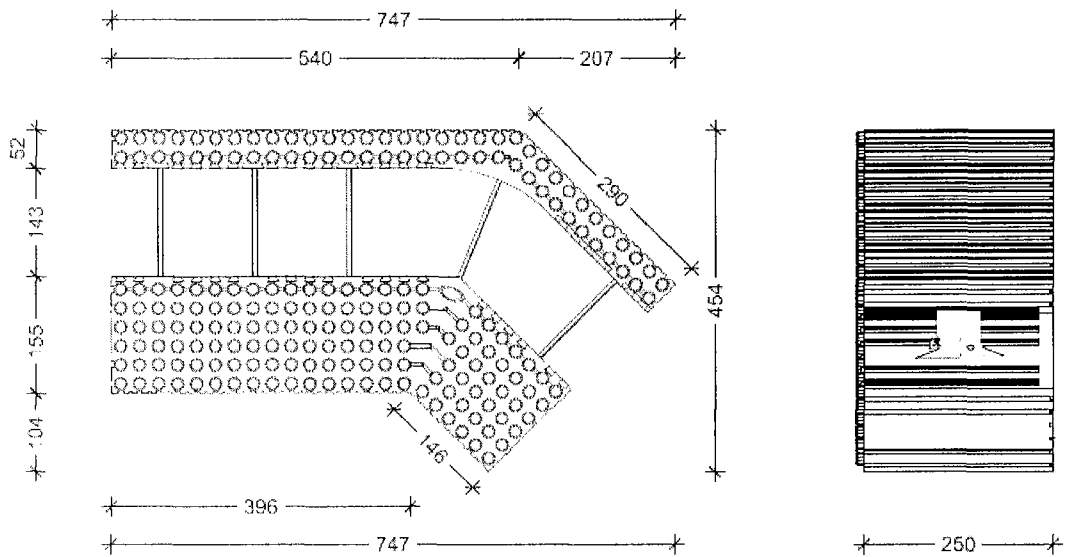

all dimensions in mm

BEWA GmbH
ARGISOL - Bausysteme

Inside Corner and angular elements
with concrete core of 14.3 cm and
an overall wall thickness of 35.0 cm

Annex 10.3
of European
Technical Approval

ETA – 05/0170

T - element
500 x 625 x 250

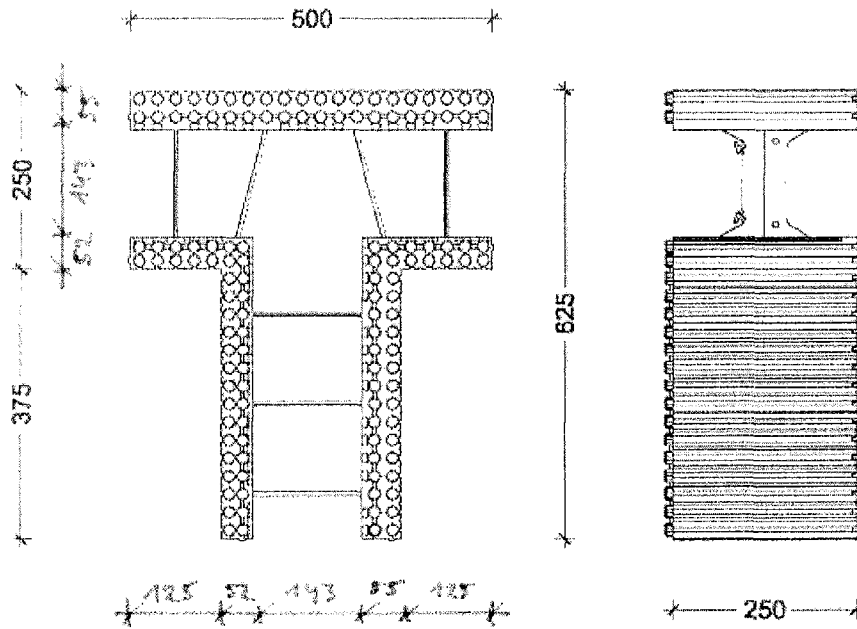

T - element
1000 x 375 x 250

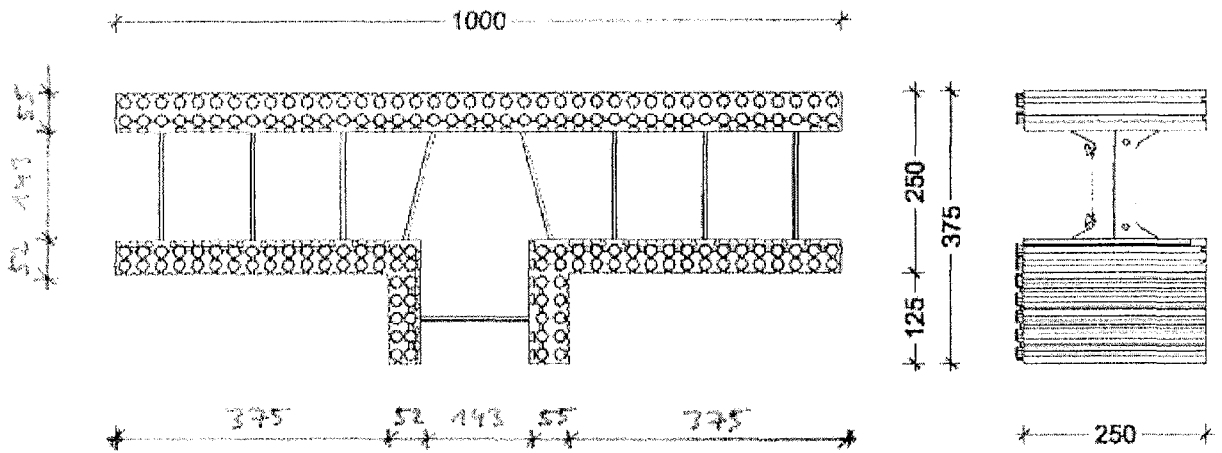

all dimensions in mm

BEWA GmbH
ARGISOL - Bausysteme

T-elements
with concrete core of 14.3 cm
only for an overall wall thickness of 25.0 cm

Annex 11
of European
Technical Approval

ETA - 05/0170

Standard element 1/2 height
1000 x 350 x 125 mm

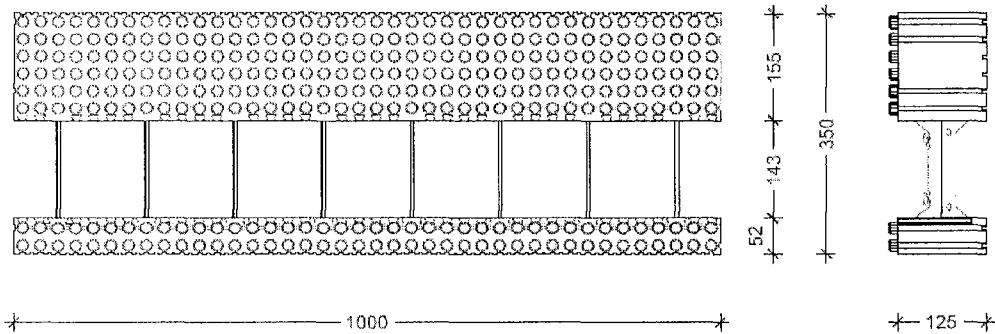

Lintel element
750 x 350 x 250 mm

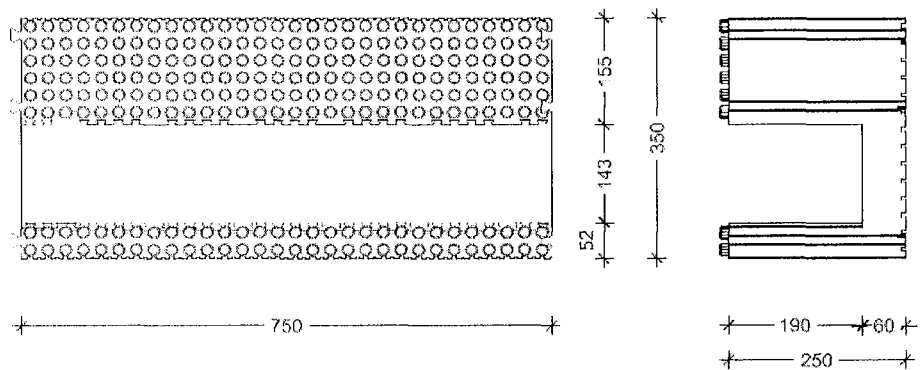

Height compensation element
500 x 150 x 50 mm

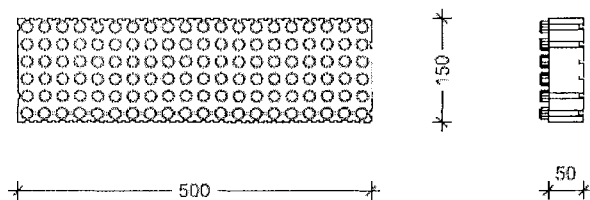

all dimensions in mm

BEWA GmbH
ARGISOL - Bausysteme

Standard element 1/2 height, lintel element,
height compensation element
with concrete core of 14.3 cm
only for an overall wall thickness of 35.0 cm

Annex 12
of European
Technical Approval

ETA – 05/0170