

Deutsches Institut für Bautechnik

Anstalt des öffentlichen Rechts

Kolonnenstr. 30 L
10829 Berlin
Germany

Tel.: +49(0)30 787 30 0
Fax: +49(0)30 787 30 320
E-mail: dibt@dibt.de
Internet: www.dibt.de



DIBt

Mitglied der EOTA
Member of EOTA

European Technical Approval ETA-08/0284

English translation prepared by DIBt - Original version in German language

Handelsbezeichnung
Trade name

Glassline Punkthalter
Glassline Point Fasteners

Zulassungsinhaber
Holder of approval

Glassline GmbH
Industriestraße 7-8
74740 Adelsheim
DEUTSCHLAND

Zulassungsgegenstand
und Verwendungszweck
*Generic type and use
of construction product*

Punkthalter
Point Fasteners

Geltungsdauer: vom
Validity: from
bis
to

20 April 2010
18 November 2013

Herstellwerk
Manufacturing plant

Glassline GmbH
Industriestraße 7-8
74740 Adelsheim
DEUTSCHLAND

Diese Zulassung umfasst
This Approval contains

18 Seiten einschließlich 10 Anhänge
18 pages including 10 annexes

Diese Zulassung ersetzt
This Approval replaces

ETA-08/0284 mit Geltungsdauer vom 18.11.2008 bis 18.11.2013
ETA-08/0284 with validity from 18.11.2008 to 18.11.2013



Europäische Organisation für Technische Zulassungen
European Organisation for Technical Approvals

I LEGAL BASES AND GENERAL CONDITIONS

- 1 This European technical approval is issued by Deutsches Institut für Bautechnik in accordance with:
 - Council Directive 89/106/EEC of 21 December 1988 on the approximation of laws, regulations and administrative provisions of Member States relating to construction products¹, modified by Council Directive 93/68/EEC² and Regulation (EC) N° 1882/2003 of the European Parliament and of the Council³;
 - Gesetz über das In-Verkehr-Bringen von und den freien Warenverkehr mit Bauprodukten zur Umsetzung der Richtlinie 89/106/EWG des Rates vom 21. Dezember 1988 zur Angleichung der Rechts- und Verwaltungsvorschriften der Mitgliedstaaten über Bauprodukte und anderer Rechtsakte der Europäischen Gemeinschaften (Bauproduktengesetz - BauPG) vom 28. April 1998⁴, as amended by law of 31 October 2006⁵;
 - Common Procedural Rules for Requesting, Preparing and the Granting of European technical approvals set out in the Annex to Commission Decision 94/23/EC⁶.
- 2 Deutsches Institut für Bautechnik is authorized to check whether the provisions of this European technical approval are met. Checking may take place in the manufacturing plant. Nevertheless, the responsibility for the conformity of the products to the European technical approval and for their fitness for the intended use remains with the holder of the European technical approval.
- 3 This European technical approval is not to be transferred to manufacturers or agents of manufacturers other than those indicated on page 1, or manufacturing plants other than those indicated on page 1 of this European technical approval.
- 4 This European technical approval may be withdrawn by Deutsches Institut für Bautechnik, in particular pursuant to information by the Commission according to Article 5(1) of Council Directive 89/106/EEC.
- 5 Reproduction of this European technical approval including transmission by electronic means shall be in full. However, partial reproduction can be made with the written consent of Deutsches Institut für Bautechnik. In this case partial reproduction has to be designated as such. Texts and drawings of advertising brochures shall not contradict or misuse the European technical approval.
- 6 The European technical approval is issued by the approval body in its official language. This version corresponds fully to the version circulated within EOTA. Translations into other languages have to be designated as such.

1 Official Journal of the European Communities L 40, 11 February 1989, p. 12

2 Official Journal of the European Communities L 220, 30 August 1993, p. 1

3 Official Journal of the European Union L 284, 31 October 2003, p. 25

4 *Bundesgesetzblatt Teil I 1998*, p. 812

5 *Bundesgesetzblatt Teil I 2006*, p. 2407, 2416

6 Official Journal of the European Communities L 17, 20 January 1994, p. 34

II SPECIFIC CONDITIONS OF THE EUROPEAN TECHNICAL APPROVAL

1 Definition of the product and intended use

1.1 Definition of the construction product

The construction products are prefabricated point fasteners according to Table 1.

Table 1: Types of Point fastener

Type	exterior point fastener according to Annex 1		embedded point fastener according to Annex 2	
Support type	ridged	hinged	ridged	hinged
Designation	PH 705	PH 791	PH 701	PH 789
		PH 793	PH 703	PH 790
	PH707	PH 794	PH 710	PH 792
		PH 800		PH 799

The point fasteners are manufactured of stainless steel according to EN 10088-3:2005, and, dependent on the construction type and bearing type, consist of one circular fastener or sunk fastener disk and a bearing disk (diameter dependent on system size from 45 mm to 80 mm), installation parts with inner and outer threads, POM sleeves, EPDM seals as well as, if appropriate, ball head bolts, locking rings and joint seals made of silicone.

The hinges of the point fastener PH 794 allow rotation of up to 8.7°. Rotation of the point fasteners PH 800 is possible up to 5.8°, and rotation of the remaining jointed point fasteners is up to 12° in relation to the symmetrical axis.

1.2 Intended use

The point fasteners are intended to be used for accessible pinned suspensions of wall claddings (e.g. wall glazing) with a thickness of 6 to 50 mm with a inclination up to 10° relating to the vertical and predominantly static loading. The point fasteners are connected to the substructure by threaded bolts.

The provisions made in this European technical approval are based on an assumed working life of the point fastener of 25 years. The indications given on the working life cannot be interpreted as a guarantee given by the producer, but are to be regarded only as a means for choosing the right products in relation to the expected economically reasonable working life of the works.

2 Characteristics of the product and methods of verification

2.1 Characteristics of the product

The point fasteners shall correspond to the drawings given in the Annexes.

The material properties, the dimensions and tolerances of the components made from stainless steel, EPDM, POM and where applicable silicone shall correspond to the respective values laid down in the technical documentation⁷ to this European Technical Approval.

The characteristic values of the shear, tension, compression and bending resistance of the point fasteners are given in Annexes 7 and 8 and for the embedded point fasteners in the Annexes 9 and 10.

⁷ The technical documentation is deposited with Deutsches Institut für Bautechnik and as far as relevant for the tasks of the approved bodies involved in the attestation of conformity procedure is handed over to the approved bodies.

The metal components of the point fasteners are considered to satisfy the requirements of performance class A1 of the characteristic reaction to fire. The POM-, silicone- and EPDM-components of the point fastener are classified as class F (no performance determined).

2.2 Methods of verification

The assessment of fitness of the point fasteners for the intended use (see Annex 3) in relation to the requirements for safety in case of fire and safety in use in the sense of the Essential Requirements No. 2 and No. 4 has been made in accordance with the CUAP 06.02/03, Final version, June 2003, Amendment August 2008 ("Common Understanding and Assessment Procedure") for Point Fastener.

Concerning Essential Requirement No. 2 (safety in case of fire) the following applies:

The assessment of the resistance to fire performance is only relevant to the assembled system (point fasteners, cladding, tension rods, substructure) which is not part of the ETA.

The metal components of the point fasteners are considered to satisfy the requirements of performance class A 1 of the characteristic reaction to fire, in accordance with the provisions of the EC Decision 96/603/EC (as amended) without the need for testing on the basis of its listing in that decision.

The plastic, silicone and EPDM components of the point fastener are classified as class F (no performance determined).

Concerning Essential Requirement No. 4 (safety in use) the following applies:

The characteristic values of the resistance as well as the values of the shear stiffness given in Annexes were determined by shear tests and tension tests.

3 Evaluation and attestation of conformity and CE marking

3.1 System of attestation of conformity

According to the Decision 99/92/EC of the European Commission⁸ system 2+ of the attestation of conformity applies.

This system of attestation of conformity is defined as follows:

System 2+: Declaration of conformity of the product by the manufacturer on the basis of:

- (a) Tasks for the manufacturer:
 - (1) initial type-testing of the product;
 - (2) factory production control;
 - (3) testing of samples taken at the factory in accordance with a prescribed test plan.
- (b) Tasks for the approved body:
 - (4) certification of factory production control on the basis of:
 - initial inspection of factory and of factory production control;
 - continuous surveillance, assessment and approval of factory production control.

Note: Approved bodies are also referred to as "notified bodies".

⁸ Official Journal of the European Communities L 80 of 18.03.1998

3.2 Responsibilities

3.2.1 Tasks for the manufacturer

3.2.1.1 Factory production control

The manufacturer shall exercise permanent internal control of production. All the elements, requirements and provisions adopted by the manufacturer shall be documented in a systematic manner in the form of written policies and procedures, including records of results performed. This production control system shall insure that the product is in conformity with this European technical approval.

The manufacturer may only use initial materials with the relevant inspection documents stated in the technical documentation of this European technical approval.

The factory production control shall be in accordance with the control plan of November 2008 relating to the European technical approval which is part of the technical documentation of this European technical approval. The control plan is laid down in the context of the factory production control system operated by the manufacturer and deposited with Deutsches Institut für Bautechnik.⁹

The results of factory production control shall be recorded and evaluated in accordance with the provisions of the control plan.

3.2.1.2 Other tasks for the manufacturer

The manufacturer shall, on the basis of a contract, involve a body which is approved for the tasks referred to in section 3.1 in the field of point fasteners in order to undertake the actions laid down in section 3.2.2. For this purpose, the control plan referred to in sections 3.2.1.1 and 3.2.2 shall be handed over by the manufacturer to the approved body involved.

The manufacturer shall make a declaration of conformity, stating that the construction product is in conformity with the provisions of this European technical approval.

3.2.2 Tasks for the approved bodies

The approved body shall perform the

- initial inspection of factory and of factory production control,
- continuous surveillance, assessment and approval of factory production control

in accordance with the provisions laid down in the control plan.

The approved body shall retain the essential points of its actions referred to above and state the results obtained and conclusions drawn in a written report.

The approved certification body involved by the manufacturer shall issue an EC certificate of conformity of the factory production control stating the conformity with the provisions of this European technical approval.

In cases where the provisions of the European technical approval and its control plan are no longer fulfilled the certification body shall withdraw the certificate of conformity and inform Deutsches Institut für Bautechnik without delay.

3.3 CE marking

The CE marking shall be affixed on each packaging of point fasteners. The letters "CE" shall be followed by the identification number of the approved certification body, where relevant, and be accompanied by the following additional information:

- the name and address of the producer (legal entity responsible for the manufacture),
- the last two digits of the year in which the CE marking was affixed,
- the number of the EC certificate for the factory production control,
- the number of the European technical approval,
- name of the product,
- system size and type (e.g., PH 705).

⁹ The "control plan" is a confidential part of the European technical approval and only handed over to the approved body involved in the procedure of attestation of conformity. See section 3.2.2.

4 Assumptions under which the fitness of the product for the intended use was favourably assessed

4.1 Manufacturing

The point fastener is manufactured in accordance with the provisions of the European technical approval using the manufacturing process as laid down in the technical documentation.

The European technical approval is issued for the product on the basis of agreed data/information, deposited with Deutsches Institut für Bautechnik, which identifies the product that has been assessed and judged. Changes to the product or production process, which could result in this deposited data/information being incorrect, should be notified to Deutsches Institut für Bautechnik before the changes are introduced. Deutsches Institut für Bautechnik will decide whether or not such changes affect the approval and consequently the validity of the CE marking on the basis of the approval and if so whether further assessment or alterations to the approval shall be necessary.

4.2 Design

The fitness for the intended use of the point fasteners is given under the following conditions:

The loading is predominantly static.

The permanent serviceability of the hinge of the hinged point fasteners is ensured.

Dimensions, material properties and installation instruction as stated in the ETA are observed.

For the design of the point fasteners the verification concept stated in EN 1990:2002 is used. The characteristic values of the point fasteners stated in the Annexes 7 to 10 are only used for the design of the point fasteners themselves.

The following conditions are verified using the basic combination of actions:

$$\frac{V_d \cdot \gamma_M}{V_{R,k}} \leq 1$$

$$\frac{N_d \cdot \gamma_M}{N_{R,k}} + \frac{M_d \cdot \gamma_M}{M_{R,k}} \leq 1$$

With:

V_d The design value of the shear force in the ultimate limit state

N_d The design value of the normal force (tension or compression force) in the ultimate limit state

M_d The design value of the bending moment (for rigid point fasteners only) in the ultimate limit state

$V_{R,k}$ The characteristic value of the shear resistance

$N_{R,k}$ The characteristic value of the tension/compression resistance

$M_{R,k}$ The characteristic value of the bending resistance

γ_M Recommended partial safety = 1,375

The value given for the partial safety factor γ_M is a recommended value. It should be used in cases where no value is given in the national regulations of the Member State where the point fasteners are used or in the respective National Annex to EN 1993 (Eurocode 3).

The resistance of the assembled / installed system (point fastener, cladding, tension rods, substructure), which is not covered by the ETA, is determined separately.

The resistance to fire of the assembled/installed system (point fastener, cladding, tension rods, substructure), which is not covered by the ETA, is determined separately, provided requirements concerning resistance to fire exist.

Design is carried out by the designer of the structure experienced in the field of steel structures.

4.3 Installation

The fitness for the intended use of the point fasteners (see Annex 3) is given under the following conditions:

The installation is carried out such that the point fasteners are accessible for repair or maintenance at any time.

The installation is only carried out according to the manufacturer's instructions. The manufacturer hands over the assembly instructions to the assembler. From the assembly instructions it shall be followed that, prior to the installation, all point fasteners shall be checked for their perfect condition and that damaged point fasteners shall not be used.

The permanent serviceability of the hinge of the hinged point fasteners is ensured by a joint protection seal.

The point fasteners are fastened by a tightening torque moment of 8 Nm.

All connecting bolts are secured against unscrewing (e.g. using a liquid screw adhesive such as LOCTITE).

During installation, the connecting bolts are not installed turned more than 3° away from their intended position (symmetrical axis).

The hole diameters / tolerances as stated in the Annexes 3 to 6 are taken into account.

The conformity of the installed point fastener with the provisions of the ETA is attested by the executing assembler.

5 Indications to the manufacturer

It is in the responsibility of the manufacturer to ensure that the information on the specific conditions according to 1, 2, 4.2 and 4.3 (including Annexes referred to) is given to those who are concerned. This information may be given by reproduction of the respective parts of the European technical approval. In addition all installation data shall be shown clearly on the package and/or on an enclosed instruction sheet, preferably using illustration(s).

The point fasteners shall be packaged and supplied as complete units only.

Dipl.-Ing. Georg Feistel
Head of Division Construction Engineering
of Deutsches Institut für Bautechnik
Berlin, 20 April 2010

beglaubigt
Schult

Rigid exterior point fastener

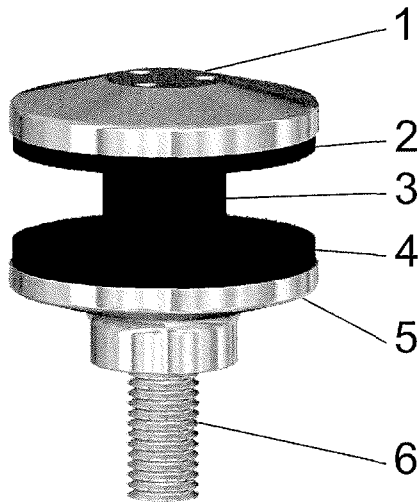

- 1 Holding disk
- 2 EPDM seal
- 3 POM sleeve
- 4 EPDM bearing seal
- 5 Bearing disk
- 6 Connecting bolt

Hinged exterior point fastener

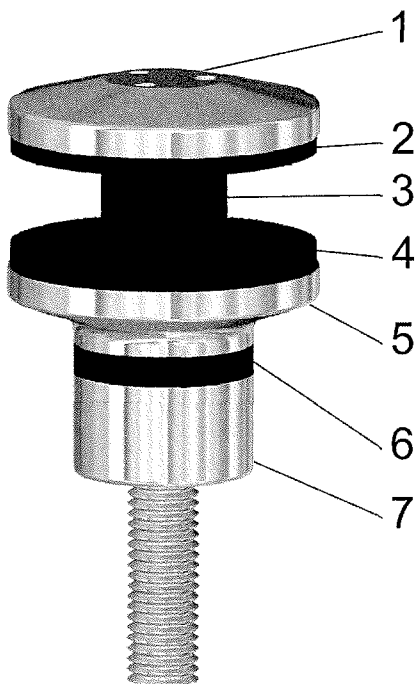

- 1 Holding disk
- 2 EPDM seal
- 3 POM sleeve
- 4 EPDM bearing seal
- 5 Bearing disk with ball head and locking ring
- 6 Joint seal
- 7 Connecting bolt

Glassline - point fasteners

Rigid and hinged exterior point fasteners

Annex 1
to European
technical approval
ETA-08/0284

Rigid embedded point fastener

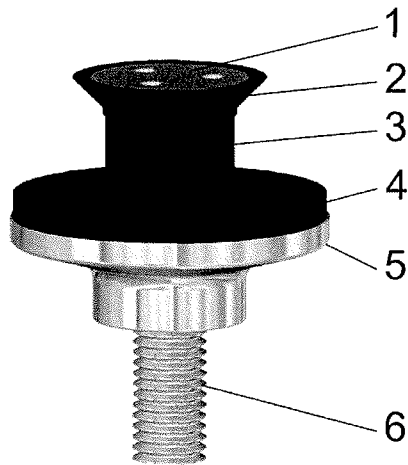

- 1 Embedded point fastener disk
- 2 POM sunk sleeve
- 3 POM sleeve
- 4 EPDM bearing seal
- 5 Bearing disk
- 6 Connecting bolt

Hinged embedded point fastener

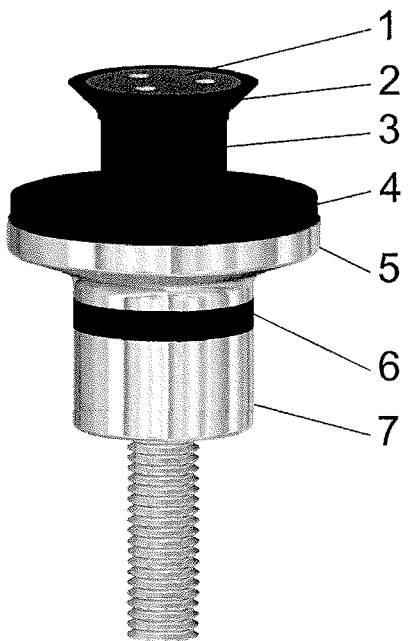

- 1 Embedded point fastener disk
- 2 POM sunk sleeve
- 3 POM sleeve
- 4 EPDM bearing seal
- 5 Bearing disk with ball head and locking ring
- 6 Joint seal
- 7 Connecting bolt

Glassline - point fasteners

Rigid and hinged embedded point fasteners

Annex 2
to European
technical approval
ETA-08/0284

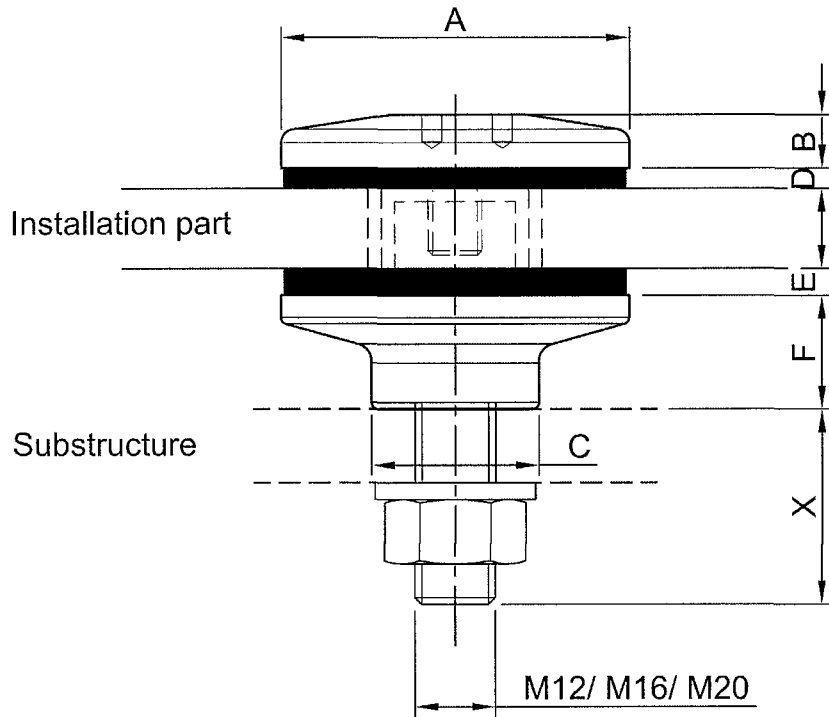

Drilling template

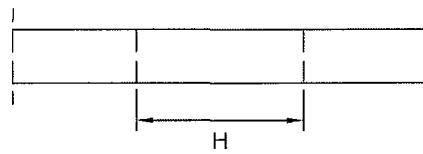

Point fastener	Dimensions in mm							
	A	B	C	D	E	F	X	H
PH705	52	8	25	3	4	10 - 100	15 - 150	$\text{Ø } 25^{+0.5}_{-0.0}$
PH707	68	8	25	3	4	10 - 100	15 - 150	$\text{Ø } 25^{+0.5}_{-0.0}$

Glassline - point fasteners

Dimensions of the rigid exterior point fasteners
 PH705 and PH707

Annex 3
 to European
 technical approval
ETA-08/0284

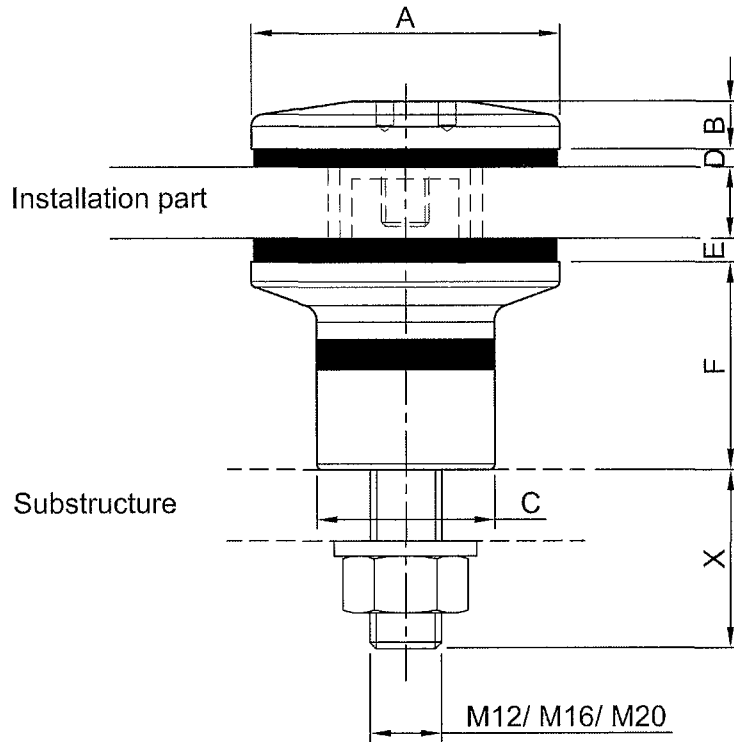

Drilling template

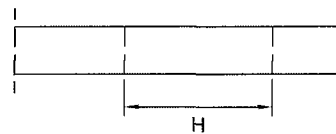

Point fastener	Dimensions in mm							
	A	B	C	D	E	F	X	H
PH791	68	8	30	3	4	35 - 100	15 - 150	Ø 35 ^{+0.5} _{-0.0}
PH793	52	8	30	3	4	35 - 100	15 - 150	Ø 25 ^{+0.5} _{-0.0}
PH794	45	8	30	3	4	35 - 100	15 - 150	Ø 25 ^{+0.5} _{-0.0}
PH800	80	8	30	3	4	35 - 100	15 - 150	Ø 35 ^{+0.5} _{-0.0}

Glassline - point fasteners

Dimensions of the hinged exterior point fasteners
 PH791, PH793, PH794 and PH800

Annex 4
 to European
 technical approval
ETA-08/0284

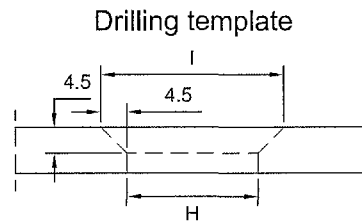
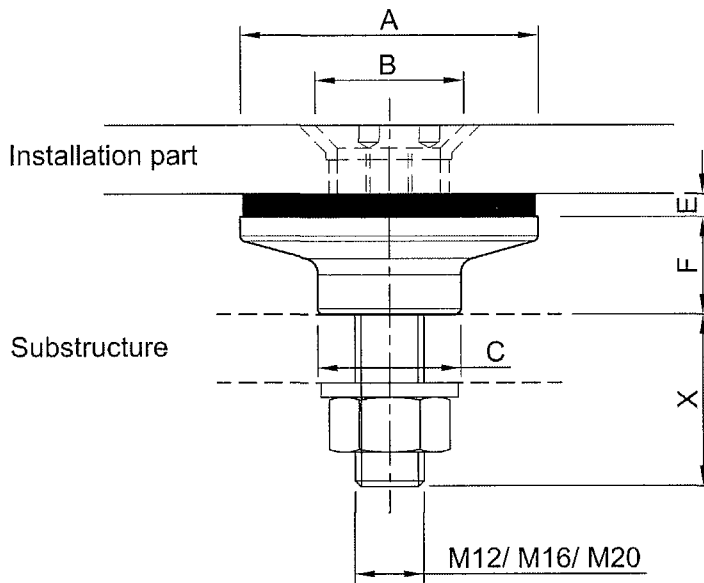

Point fastener	Dimensions in mm							
	A	B	C	E	F	X	H	I
PH701	52	26	25	4	10 - 100	15 - 150	Ø 23 ^{+0.5} _{-0.0}	Ø 32 ^{+0.5} _{-0.0}
PH703	68	42	25	4	105 - 100	15 - 150	Ø 39 ^{+0.5} _{-0.0}	Ø 48 ^{+0.5} _{-0.0}
PH710	45	26	25	4	10 - 100	15 - 150	Ø 23 ^{+0.5} _{-0.0}	Ø 32 ^{+0.5} _{-0.0}

Glassline - point fasteners

Dimensions of the rigid embedded point fasteners
 PH701, PH703 and PH710

Annex 5
 to European
 technical approval
ETA-08/0284

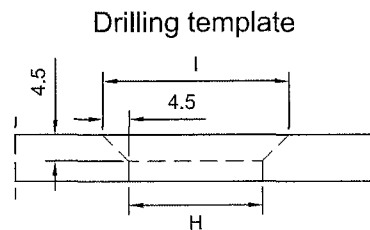
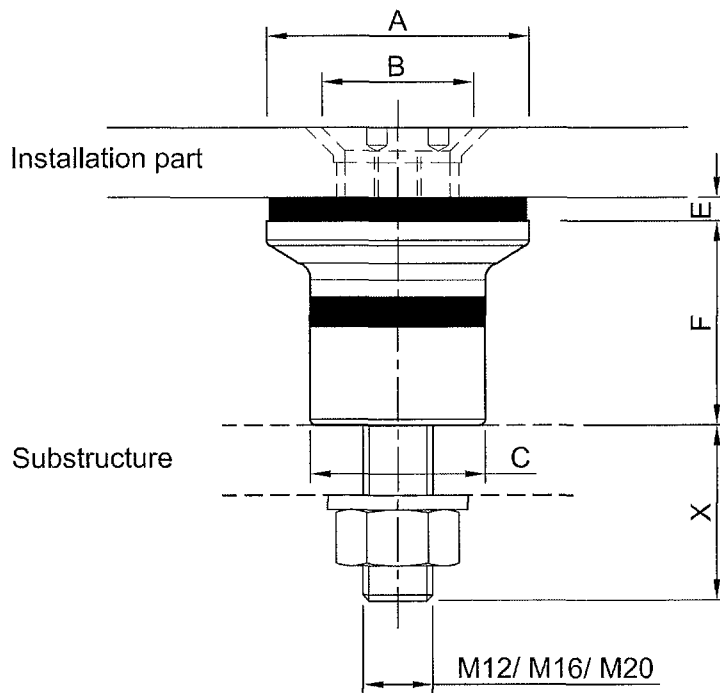

Point fastener	Dimensions in mm							
	A	B	C	E	F	X	H	I
PH789	45	26	30	4	35 - 100	15 - 150	$\text{Ø } 23^{+0.5}_{-0.0}$	$\text{Ø } 32^{+0.5}_{-0.0}$
PH790	68	42	30	4	35 - 100	15 - 150	$\text{Ø } 39^{+0.5}_{-0.0}$	$\text{Ø } 48^{+0.5}_{-0.0}$
PH792	52	26	30	4	35 - 100	15 - 150	$\text{Ø } 23^{+0.5}_{-0.0}$	$\text{Ø } 32^{+0.5}_{-0.0}$
PH799	80	26	30	4	35 - 100	15 - 150	$\text{Ø } 39^{+0.5}_{-0.0}$	$\text{Ø } 48^{+0.5}_{-0.0}$

Glassline - point fasteners

Dimensions of the hinged embedded point fasteners
 PH789, PH790, PH792 and PH799

Annex 6
 to European
 technical approval
ETA-08/0284

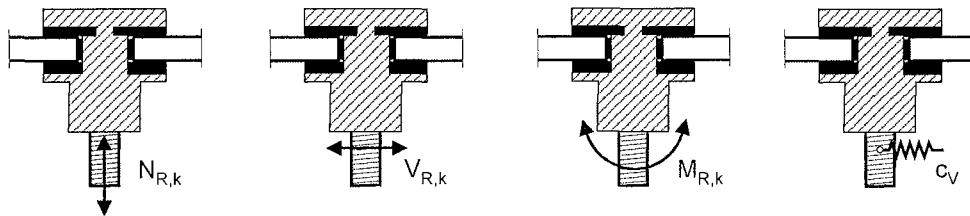

Point fastener	Tension and compression resistance $N_{R,k}$	Shear resistance $V_{R,k}$	Bending resistance $M_{R,k}$	Shear stiffness c_v
PH705	10.80 kN	6.00 kN	0.39 kNm	2410 N/mm
PH707	14.82 kN	6.00 kN	0.51 kNm	4840 N/mm

Glassline - point fasteners

Characteristic values of resistance and shear stiffness
 of the rigid exterior point fasteners PH705 and PH707

Annex 7
 to European
 technical approval
ETA-08/0284

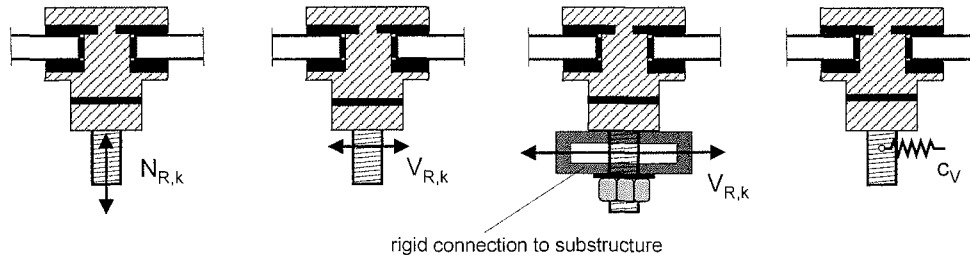

Point fastener	Tension and compression resistance $N_{R,k}$	Shear resistance $V_{R,k}$	Shear resistance for rigid connection to substructure $V_{R,k}$	Shear stiffness c_v
PH791	14.82 kN	5.88 kN	23.20 kN	430 N/mm
PH793	10.80 kN	6.96 kN	17.22 kN	340 N/mm
PH794	10.80 kN	6.70 kN	13.82 kN	310 N/mm
PH800	17.90 kN	6.32 kN	19.30 kN	400 N/mm

Glassline - point fasteners

Annex 8
 to European
 technical approval
ETA-08/0284

Characteristic values of resistance and shear stiffness
 of the hinged exterior point fasteners PH791, PH793, PH794 and PH800

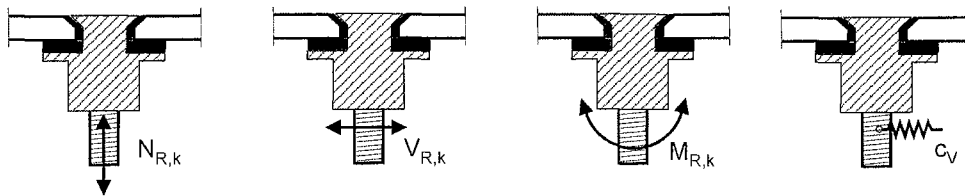

Point fastener	Tension and compression resistance $N_{R,k}$	Shear resistance $V_{R,k}$	Bending resistance $M_{R,k}$	Shear stiffness c_v
PH701	10.80 kN	6.00 kN	0.39 kNm	2710 N/mm
PH703	13.90 kN	6.00 kN	0.51 kNm	5500 N/mm
PH710	10.80 kN	6.00 kN	0.34 kNm	2010 N/mm

Glassline - point fasteners

Characteristic values of resistance and shear stiffness
 of the rigid embedded point fasteners PH701, PH703 and PH710

Annex 9
 to European
 technical approval
ETA-08/0284

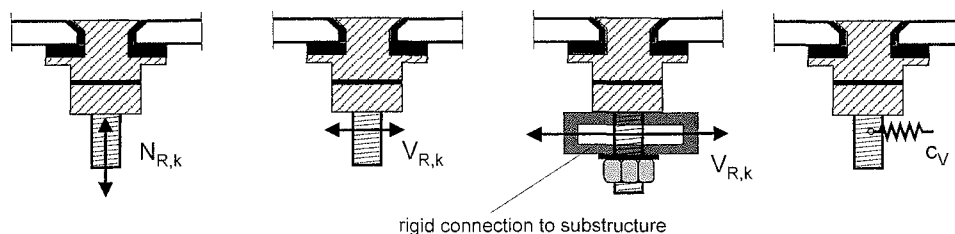

Point fastener	Tension and compression resistance $N_{R,k}$	Shear resistance $V_{R,k}$	Shear resistance for rigid connection to substructure $V_{R,k}$	Shear stiffness c_v
PH789	10.80 kN	5.98 kN	10.06 kN	330 N/mm
PH790	13.90 kN	6.52 kN	15.12 kN	340 N/mm
PH792	10.80 kN	6.82 kN	8.58 kN	310 N/mm
PH799	16.04 kN	7.60 kN	16.60 kN	350 N/mm

Glassline - point fasteners

Characteristic values of resistance and shear stiffness of the hinged embedded point fasteners PH789, PH790, PH792 and PH799

Annex 10
 to European
 technical approval
ETA-08/0284