

# Deutsches Institut für Bautechnik

Anstalt des öffentlichen Rechts

Kolonnenstr. 30 L  
10829 Berlin  
Germany

Tel.: +49(0)30 787 30 0  
Fax: +49(0)30 787 30 320  
E-mail: [dibt@dibt.de](mailto:dibt@dibt.de)  
Internet: [www.dibt.de](http://www.dibt.de)

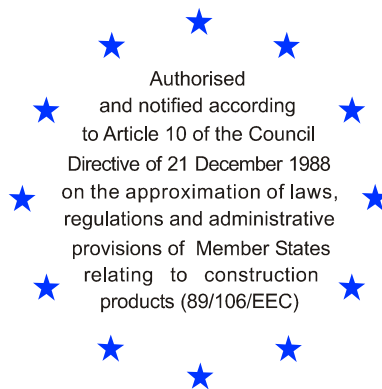

# DIBt

Mitglied der EOTA  
*Member of EOTA*

## European Technical Approval ETA-09/0395

English translation prepared by DIBt - Original version in German language

Handelsbezeichnung  
*Trade name*

Würth Schraubanker W-SA/S  
*Würth Screw Anchor W-SA/S*

Zulassungsinhaber  
*Holder of approval*

Adolf Würth GmbH & Co. KG  
Reinhold-Würth-Straße 12-17  
74653 Künzelsau  
DEUTSCHLAND

Zulassungsgegenstand  
und Verwendungszweck  
*Generic type and use  
of construction product*

Betonschraube Ø 12 aus galvanisch verzinktem Stahl zur  
Verankerung im Beton  
*Concrete screw Ø 12 made of galvanised steel for use in concrete*

Geltungsdauer: vom  
*Validity: from*  
bis  
*to*

16 September 2010  
19 January 2015

Herstellwerk  
*Manufacturing plant*

Würth Herstellwerke W1, W15

Diese Zulassung umfasst  
*This Approval contains*

16 Seiten einschließlich 9 Anhänge  
*16 pages including 9 annexes*

Diese Zulassung ersetzt  
*This Approval replaces*

ETA-09/0395 mit Geltungsdauer vom 19.01.2010 bis 19.01.2015  
*ETA-09/0395 with validity from 19.01.2010 to 19.01.2015*



Europäische Organisation für Technische Zulassungen  
European Organisation for Technical Approvals

## I LEGAL BASES AND GENERAL CONDITIONS

- 1 This European technical approval is issued by Deutsches Institut für Bautechnik in accordance with:
  - Council Directive 89/106/EEC of 21 December 1988 on the approximation of laws, regulations and administrative provisions of Member States relating to construction products<sup>1</sup>, modified by Council Directive 93/68/EEC<sup>2</sup> and Regulation (EC) N° 1882/2003 of the European Parliament and of the Council<sup>3</sup>;
  - Gesetz über das In-Verkehr-Bringen von und den freien Warenverkehr mit Bauprodukten zur Umsetzung der Richtlinie 89/106/EWG des Rates vom 21. Dezember 1988 zur Angleichung der Rechts- und Verwaltungsvorschriften der Mitgliedstaaten über Bauprodukte und anderer Rechtsakte der Europäischen Gemeinschaften (Bauproduktengesetz - BauPG) vom 28. April 1998<sup>4</sup>, as amended by law of 31 October 2006<sup>5</sup>;
  - Common Procedural Rules for Requesting, Preparing and the Granting of European technical approvals set out in the Annex to Commission Decision 94/23/EC<sup>6</sup>;
  - Guideline for European technical approval of "Metal anchors for use in concrete - Part 3: Undercut anchors", ETAG 001-03.
- 2 Deutsches Institut für Bautechnik is authorized to check whether the provisions of this European technical approval are met. Checking may take place in the manufacturing plant. Nevertheless, the responsibility for the conformity of the products to the European technical approval and for their fitness for the intended use remains with the holder of the European technical approval.
- 3 This European technical approval is not to be transferred to manufacturers or agents of manufacturers other than those indicated on page 1, or manufacturing plants other than those indicated on page 1 of this European technical approval.
- 4 This European technical approval may be withdrawn by Deutsches Institut für Bautechnik, in particular pursuant to information by the Commission according to Article 5(1) of Council Directive 89/106/EEC.
- 5 Reproduction of this European technical approval including transmission by electronic means shall be in full. However, partial reproduction can be made with the written consent of Deutsches Institut für Bautechnik. In this case partial reproduction has to be designated as such. Texts and drawings of advertising brochures shall not contradict or misuse the European technical approval.
- 6 The European technical approval is issued by the approval body in its official language. This version corresponds fully to the version circulated within EOTA. Translations into other languages have to be designated as such.

---

1 Official Journal of the European Communities L 40, 11 February 1989, p. 12

2 Official Journal of the European Communities L 220, 30 August 1993, p. 1

3 Official Journal of the European Union L 284, 31 October 2003, p. 25

4 *Bundesgesetzblatt Teil I 1998*, p. 812

5 *Bundesgesetzblatt Teil I 2006*, p. 2407, 2416

6 Official Journal of the European Communities L 17, 20 January 1994, p. 34

## **II SPECIFIC CONDITIONS OF THE EUROPEAN TECHNICAL APPROVAL**

### **1 Definition of the construction product and intended use**

#### **1.1 Definition of the construction product**

The Würth Screw Anchor W-SA/S is an anchor made of galvanised steel of size Ø 12. The anchor is screwed into a predrilled cylindrical drill hole. The special thread of the anchor cuts an internal thread into the member while setting. The anchorage is characterised by mechanical interlock in the special thread.

An illustration of the product and intended use is given in Annex 1.

#### **1.2 Intended use**

The anchor is intended to be used for anchorages for which requirements for mechanical resistance and stability and safety in use in the sense of the Essential Requirements 1 and 4 of Council Directive 89/106 EEC shall be fulfilled and failure of anchorages made with these products would cause risk to human life and/or lead to considerable economic consequences.

The anchor may be used for anchorages with requirements related to resistance to fire.

The anchor is to be used only for anchorages subject to static or quasi-static loading in reinforced or unreinforced normal weight concrete of strength classes C20/25 at minimum and C50/60 at most according to EN 206:2000-12.

It may be anchored in cracked or non-cracked concrete.

The anchor may only be used in structures subject to dry internal conditions.

The provisions made in this European technical approval are based on an assumed working life of the anchor of 50 years. The indications given on the working life cannot be interpreted as a guarantee given by the producer, but are to be regarded only as a means for choosing the right products in relation to the expected economically reasonable working life of the works.

### **2 Characteristics of the product and methods of verification**

#### **2.1 Characteristics of the product**

The anchor corresponds to the drawings and information given in Annexes 1 and 2. The characteristic material values, dimensions and tolerances of the anchor not indicated in Annexes 1 and 2 shall correspond to the respective values laid down in the technical documentation<sup>7</sup> of this European technical approval.

Regarding the requirements concerning safety in case of fire it is assumed that the anchor meets the requirements of class A1 in relation to reaction to fire in accordance with the stipulations of the Commission decision 96/603/EC, amended by 2000/605/EC.

The characteristic values for the design of the anchorages in accordance with the "Guideline for European technical approval of Metal Anchors for use in concrete", Annex C, Method A are given in Annex 3 and 4.

The characteristic values for the design of anchorages regarding resistance to fire are given in the Annex 8. They are valid for use in a system that is required to provide a specific fire resistance class.

The characteristic values for the design of the anchorages in accordance with the design method A of CEN/TS 1992-4-4 are given in Annex 5 and 6.

---

<sup>7</sup> The technical documentation of this European technical approval is deposited at the Deutsches Institut für Bautechnik and, as far as relevant for the tasks of the approved bodies involved in the attestation of conformity procedure, is handed over to the approved bodies.

Each anchor shall be marked with the works symbol, the anchor type, number of producer, the length of the anchor  $L_s$  and the length of the special thread  $L_g$  according to Annex 1.

## 2.2 Methods of verification

The assessment of fitness of the anchor for the intended use in relation to the requirements for mechanical resistance and stability and safety in use in the sense of the Essential Requirements 1 and 4 has been made in accordance with the "Guideline for European technical approval of Metal Anchors for use in concrete", Part 1 "Anchors in general" and Part 3 "Undercut anchors", on the basis of Option 1.

The assessment of the anchor for the intended use in relation to the requirements for resistance to fire has been made in accordance with the Technical Report TR 020 "Evaluation of anchorages in concrete concerning resistance to fire".

In addition to the specific clauses relating to dangerous substances contained in this European technical approval, there may be other requirements applicable to the products falling within its scope (e.g. transposed European legislation and national laws, regulations and administrative provisions). In order to meet the provisions of the Construction Products Directive, these requirements need also to be complied with, when and where they apply.

## 3 Evaluation and attestation of conformity and CE marking

### 3.1 System of attestation of conformity

According to the decision 96/582/EG of the European Commission<sup>8</sup> the system 2(i) (referred to as system 1) of attestation of conformity applies.

This system of attestation of conformity is defined as follows:

System 1: Certification of the conformity of the product by an approved certification body on the basis of:

- (a) Tasks for the manufacturer:
  - (1) factory production control;
  - (2) further testing of samples taken at the factory by the manufacturer in accordance with a prescribed control plan;
- (b) Tasks for the approved body:
  - (3) initial type-testing of the product;
  - (4) initial inspection of factory and of factory production control;
  - (5) continuous surveillance, assessment and approval of factory production control.

Note: Approved bodies are also referred to as "notified bodies".

### 3.2 Responsibilities

#### 3.2.1 Tasks of the manufacturer

##### 3.2.1.1 Factory production control

The manufacturer shall exercise permanent internal control of production. All the elements, requirements and provisions adopted by the manufacturer shall be documented in a systematic manner in the form of written policies and procedures, including records of results performed. This production control system shall insure that the product is in conformity with this European technical approval.

The manufacturer may only use initial / raw / constituent materials stated in the technical documentation of this European technical approval.

---

<sup>8</sup> Official Journal of the European Communities L 254 of 08.10.1996.

The factory production control shall be in accordance with the control plan which is part of the technical documentation of this European technical approval. The control plan is laid down in the context of the factory production control system operated by the manufacturer and deposited at Deutsches Institut für Bautechnik.<sup>9</sup>

The results of factory production control shall be recorded and evaluated in accordance with the provisions of the control plan.

#### 3.2.1.2 Other tasks of manufacturer

The manufacturer shall, on the basis of a contract, involve a body which is approved for the tasks referred to in section 3.1 in the field of anchors in order to undertake the actions laid down in section 3.2.2. For this purpose, the control plan referred to in sections 3.2.1.1 and 3.2.2 shall be handed over by the manufacturer to the approved body involved.

The manufacturer shall make a declaration of conformity, stating that the construction product is in conformity with the provisions of this European technical approval.

#### 3.2.2 Tasks of approved bodies

The approved body shall perform the

- initial type-testing of the product,
- initial inspection of factory and of factory production control,
- continuous surveillance, assessment and approval of factory production control,

in accordance with the provisions laid down in the control plan.

The approved body shall retain the essential points of its actions referred to above and state the results obtained and conclusions drawn in a written report.

The approved certification body involved by the manufacturer shall issue an EC certificate of conformity of the factory production control stating the conformity with the factory production control of this European technical approval.

In cases where the provisions of the European technical approval and its control plan are no longer fulfilled the certification body shall withdraw the certificate of conformity and inform Deutsches Institut für Bautechnik without delay.

### 3.3 CE marking

The CE marking shall be affixed on each packaging of the anchors. The letters "CE" shall be followed by the identification number of the approved certification body, where relevant, and be accompanied by the following additional information:

The CE marking shall be affixed on each packaging of the anchor. The letters "CE" shall be followed by the identification number of the approved certification body, where relevant, and be accompanied by the following additional information:

- the name and address of the producer (legal entity responsible for the manufacturer),
- the last two digits of the year in which the CE marking was affixed,
- the number of the EC certificate of conformity for the product,
- the number of the European technical approval,
- the number of the guideline for European technical approval,
- use category (ETAG 001-1, Option 1),
- size.

---

<sup>9</sup> The control plan is a confidential part of the documentation of the European technical approval, but not published together with the European technical approval and only handed over to the approved body involved in the procedure of attestation of conformity.  
See section 3.2.2.

## **4 Assumptions under which the fitness of the product for the intended use was favourably assessed**

### **4.1 Manufacturing**

The European technical approval is issued for the product on the basis of agreed data/information, deposited with Deutsches Institut für Bautechnik, which identifies the product that has been assessed and judged. Changes to the product or production process, which could result in this deposited data/information being incorrect, should be notified to Deutsches Institut für Bautechnik before the changes are introduced. Deutsches Institut für Bautechnik will decide whether or not such changes affect the European technical approval and consequently the validity of the CE marking on the basis of the European technical approval and if so whether further assessment or alterations to the European technical approval shall be necessary.

### **4.2 Design of anchorages**

The fitness of the anchor for the intended use is given under the following conditions:

The anchorages are designed either in accordance with the

- "Guideline for European technical approval of Metal Anchors for use in concrete", Annex C, method A

or in accordance with the

- CEN/TS 1992-4-4 "Design of fastenings for use in concrete", Part 4-4: "Post-installed fasteners – Mechanical systems", design method A,

under the responsibility of an engineer experienced in anchorages and concrete work. A mixture of the design methods is not allowed.

Verifiable calculation notes and drawings are prepared taking account of the loads to be anchored.

The position of the anchor is indicated on the design drawings (e.g. position of the anchor relative to reinforcement or to supports, in cracked or non-cracked concrete, etc.).

For anchorages under fire exposure the design has to apply either in accordance with the

- Technical Report TR 020 "Evaluation of anchorages in concrete concerning resistance to fire"

or in accordance with the

- CEN/TS 1992-4-1 "Design of fastenings for use in concrete", Part 4-1: "General".

The design methods cover anchors with a fire attack from one side only. If the fire attack is from more than one side, the design method may be taken only, if the edge distance of the anchor is  $c \geq 300$  mm.

### **4.3 Installation of anchors**

The fitness for use of the anchor can only be assumed if the following conditions of installation are met:

- Anchor installation carried out by appropriately qualified personnel under the supervision of the person responsible for technical matters on site,
- Use of the anchor only as supplied by the manufacturer,
- Anchor installation in accordance with the manufacturer's specifications and drawings,
- Checks before placing the anchor, to ensure that the characteristic values of the base material in which the anchor is to be placed, is identical with the values, which the characteristic loads apply,
- Check of the concrete being well compacted, e.g. without significant voids,
- Edge distances and spacings not less than the specified values without minus tolerances,
- Placing drill holes without damaging the reinforcement,

- In case of aborted hole: new drilling at a minimum distance away of twice the depth of the aborted hole or smaller distance if the aborted hole is filled with high strength mortar and if under shear or oblique tension load it is not the direction of the load application,
- Cleaning of the hole of drilling dust,
- Anchor installation such that the embedment depth of the anchor in the concrete is not smaller than the value  $h_{nom}$  given in Annex 2, Table 2,
- The maximum installation torque of the hexagonnut given in Annex 2, Table 2 must not be exceeded.
- The anchor may only be used once.

## 5 Responsibility of the manufacturer

The manufacturer is responsible to ensure that the information on the specific conditions according to 1 and 2 including Annexes referred to as well as sections 4.2 and 4.3 is given to those who are concerned. This information may be made by reproduction of the respective parts of the European technical approval. In addition, all installation data shall be shown clearly on the packaging and/or on an enclosed instruction sheet, preferably using illustrations.

The minimum data required are:

- Drill bit diameter,
- Size of the anchor,
- Maximum thickness of the fixture,
- Minimum embedment depth,
- Minimum hole depth,
- Information on the installation procedure, including cleaning of the hole, preferably by means of an illustration,
- Reference to any special installation equipment needed,
- Identification of the manufacturing batch.

All data shall be presented in a clear and explicit form.

Georg Feistel  
Head of Department

*beglaubigt*  
Tempel

**Intended use**

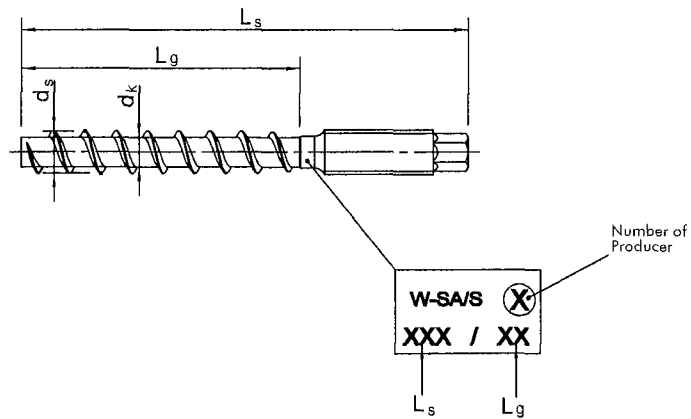
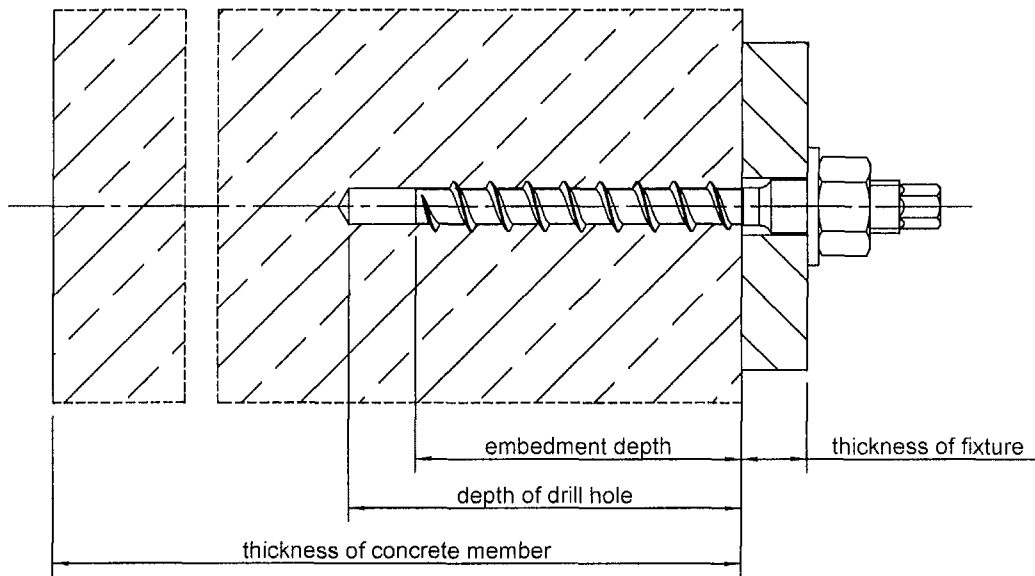

**Table 1: Dimensions and materials**

<b>Anchor size</b>			<b>Ø 12</b>
Length of screw	$L_s \geq$	[mm]	90
	$L_s \leq$	[mm]	300
Length of thread	$L_g \geq$	[mm]	75
	$L_g \leq$	[mm]	200
Bolt diameter	$d_k$	[mm]	9.15
Thread diameter	$d_s$	[mm]	12.25
Material			Zinc plated steel acc. to EN 10263-4

**Würth Screw Anchor W-SA/S**

Product and intended use  
Dimensions and materials

**Annex 1**  
of European  
technical approval  
**ETA-09/0395**



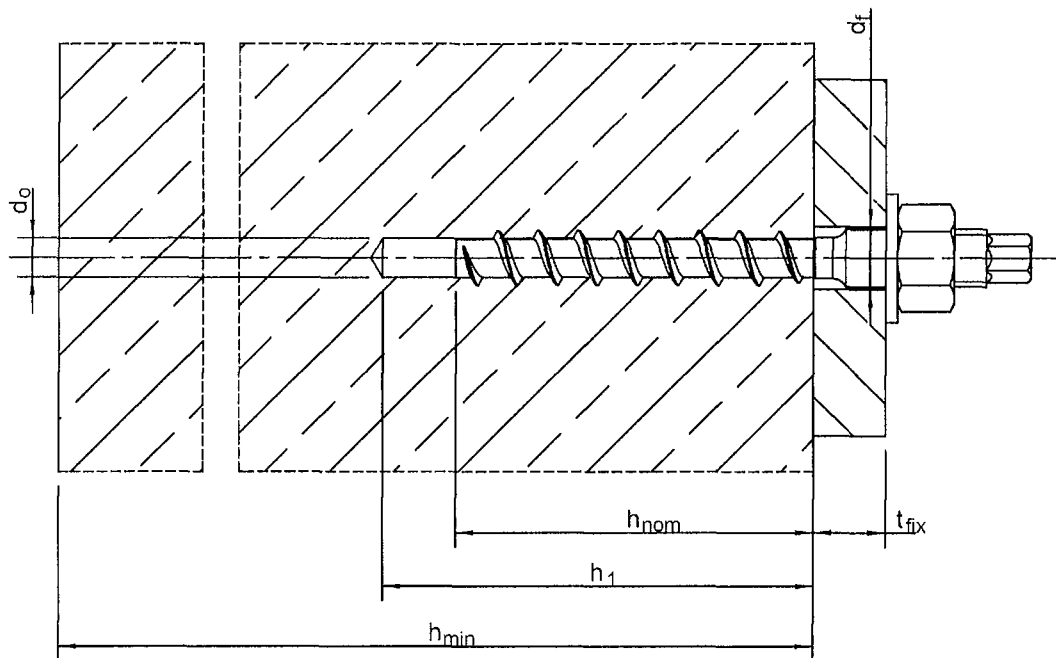

**Table 2: Installation parameters**

Anchor size			Ø 12
Nominal drill diameter	$d_0$	[mm]	10.0
Cutting diameter of the drill bit	$d_{cut} \leq$	[mm]	10.45
Depth of drill hole	$h_1 \geq$	[mm]	85
Embedment depth	$h_{nom} \geq$	[mm]	75
Diameter of clearance hole in the fixture	$d_f \leq$	[mm]	14.0
Installation torque of the hexagonnut		[Nm]	35

**Table 3: Minimum thickness of concrete member, minimum spacing and edge distance**

Anchor size			Ø 12
Minimum thickness of the concrete member	$h_{min}$	[mm]	120
<b>Cracked concrete and non-cracked concrete</b>			
Minimum spacing	$s_{min}$	[mm]	60
Minimum edge distance	$c_{min}$	[mm]	50

**Würth Screw Anchor W-SA/S**

Installation parameters,  
Minimum thickness of concrete member,  
Minimum spacing and edge distance

**Annex 2**  
of European  
technical approval  
**ETA-09/0395**

**Table 4: Characteristic values for tension loads for the design method A according to ETAG 001, Annex C**

Anchor size		Ø 12	
<b>Steel failure</b>			
Characteristic resistance	$N_{Rk,s}$	[kN]	51
Partial safety factor	$\gamma_{Ms}^{1)}$	[-]	1.4
<b>Pullout</b>			
Characteristic resistance in cracked concrete C20/25	$N_{Rk,p}$	[kN]	12
Characteristic resistance in non-cracked concrete C20/25	$N_{Rk,p}$	[kN]	16
Increasing factor for $N_{Rk,p}$ in cracked and non-cracked concrete	$\psi_c$	C30/37	1.22
		C40/50	1.41
		C50/60	1.55
Partial safety factor	$\gamma_{Mp}^{1)2)}$	[-]	1.8
<b>Concrete cone failure</b>			
Effective anchorage depth	$h_{ef}$	[mm]	56
Spacing	$s_{cr,N}$	[mm]	$3 h_{ef}$
Edge distance	$c_{cr,N}$	[mm]	$1.5 h_{ef}$
Partial safety factor	$\gamma_{Mc}^{1)2)}$	[-]	1.8
<b>Splitting failure</b>			
Spacing	$s_{cr,sp}$	[mm]	$3 h_{ef}$
Edge distance	$c_{cr,sp}$	[mm]	$1.5 h_{ef}$
Partial safety factor	$\gamma_{Msp}^{1)2)}$	[-]	1.8

<sup>1)</sup> in absence of other national regulations

<sup>2)</sup> the installation safety factor  $\gamma_2 = 1.2$  is included

**Würth Screw Anchor W-SA/S**

Design method A according to ETAG 001, Annex C;  
Characteristic values for tension loads

**Annex 3**  
of European  
technical approval  
**ETA-09/0395**

**Table 5: Characteristic values for shear loads for the design method A according to ETAG 001, Annex C**

Anchor size		Ø 12	
<b>Steel failure without lever arm</b>			
Characteristic resistance	$V_{Rk,s}$	[kN]	25
Partial safety factor	$\gamma_{Ms}^{1)}$	[-]	1.25
<b>Steel failure with lever arm</b>			
Characteristic anchor resistance	$M_{Rk,s}^0$	[Nm]	68
Partial safety factor	$\gamma_{Ms}^{1)}$	[-]	1.25
<b>Concrete pryout failure</b>			
Factor in equation 5.6 of ETAG, Annex C, section 5.2.3.3	k	[-]	2.0
Partial safety factor	$\gamma_{Mcp}^{1)}$	[-]	1.5
<b>Concrete edge failure</b>			
Effective length of the anchor in shear loading	$l_f$	[mm]	56
Effective diameter of the anchor	$d_{nom}$	[mm]	9
Partial safety factor	$\gamma_{Mc}^{1)2)}$	[-]	1.5

<sup>1)</sup> in absence of other national regulations

<sup>2)</sup> the installation safety factor  $\gamma_2 = 1.0$  is included

**Würth Screw Anchor W-SA/S**

Design method A according to ETAG 001, Annex C;  
Characteristic values for shear loads

**Annex 4**  
of European  
technical approval  
**ETA-09/0395**

**Table 6: Characteristic values for tension loads for the design method A according to CEN/TS 1992-4-4**

<b>Anchor size</b>		$\varnothing 12$	
<b>Steel failure</b>			
Characteristic resistance	$N_{Rk,s}$	[kN]	51
Partial safety factor	$\gamma_{Ms}$	[-]	1.4
<b>Pullout</b>			
Characteristic resistance in cracked concrete C20/25	$N_{Rk,p}$	[kN]	12
Partial safety factor	$\gamma_{Mp}^{1)}$	[-]	1.8
<b>Concrete cone failure</b>			
Effective anchorage depth	$h_{ef}$	[mm]	56
$k_{cr}$ -factor for cracked concrete	$k_{cr}$	[-]	7.2
$k_{ucr}$ -factor for non-cracked concrete	$k_{ucr}$	[-]	10.1
Spacing	$s_{cr,N}$	[mm]	$3 h_{ef}$
Edge distance	$c_{cr,N}$	[mm]	$1.5 h_{ef}$
Partial safety factor	$\gamma_{Mc}^{1)}$	[-]	1.8
<b>Splitting failure</b>			
Spacing	$s_{cr,sp}$	[mm]	$3 h_{ef}$
Edge distance	$c_{cr,sp}$	[mm]	$1.5 h_{ef}$
Partial safety factor	$\gamma_{Msp}^{1)}$	[-]	1.8

<sup>1)</sup> the installation safety factor  $\gamma_{inst} = 1.2$  is included

**Würth Screw Anchor W-SA/S**

Design method A according to CEN/TS 1992-4,  
Characteristic values for tension loads

**Annex 5**  
of European  
technical approval  
**ETA-09/0395**

**Table 7: Characteristic values for shear loads for the design method A according to CEN/TS 1992-4-4**

Anchor size			Ø 12
<b>Steel failure without lever arm</b>			
Characteristic resistance	$V_{Rk,s}$	[kN]	25
$k_2$ -factor	$k_2$	[-]	1.0
Partial safety factor	$\gamma_{Ms}$	[-]	1.25
<b>Steel failure with lever arm</b>			
Characteristic anchor resistance	$M_{Rk,s}^0$	[Nm]	68
Partial safety factor	$\gamma_{Ms}$	[-]	1.25
<b>Concrete pryout failure</b>			
$k_3$ -factor	$k_3$	[-]	2.0
Partial safety factor	$\gamma_{Mc}^{1)}$	[-]	1.5
<b>Concrete edge failure</b>			
Effective length of the anchor in shear loading	$l_f$	[mm]	56
Effective diameter of the anchor	$d_{nom}$	[mm]	9.0
Partial safety factor	$\gamma_{Mc}^{1)}$	[-]	1.5

<sup>1)</sup> the installation safety factor  $\gamma_{inst} = 1.0$  is included

**Würth Screw Anchor W-SA/S**

Design method A according to CEN/TS 1992-4,  
Characteristic values for shear loads

**Annex 6**  
of European  
technical approval  
**ETA-09/0395**

**Table 8: Displacements under tension loads**

Anchor size			Ø 12
Tension load in cracked and non-cracked concrete	N	[kN]	4.8
Displacement	$\delta_{N0}$	[mm]	0.2
	$\delta_{N\infty}$	[mm]	1.0

**Table 9: Displacements under shear loads**

Anchor size			Ø 12
Shear load in cracked and non-cracked concrete	V	[kN]	14.3
Displacement	$\delta_{V0}$	[mm]	3.6
	$\delta_{V\infty}$	[mm]	5.4

**Würth Screw Anchor W-SA/S**

Displacements

**Annex 7**  
of European  
technical approval  
**ETA-09/0395**

**Table 10: Characteristic values for tension loads under fire exposure in cracked and non-cracked concrete C20/25 to C50/60**

Anchor size		Ø 12				
Fire resistance duration	R	[min]	30	60	90	120
<b>Steel failure</b>						
Characteristic resistance	$N_{Rk,s,fi}$	[kN]	4.6	3.4	2.2	1.6
<b>Pullout</b>						
Characteristic resistance in concrete C20/25 to C50/60	$N_{Rk,p,fi}$	[kN]	3.0	3.0	3.0	2.4
<b>Concrete cone failure</b>						
Characteristic resistance in concrete C20/25 to C50/60	$N^0_{Rk,c,fi}$	[kN]	4.2	4.2	4.2	3.3
Spacing	$s_{cr,N}$	[mm]	4 x $h_{ef}$			
	$s_{min}$	[mm]	$s_{min}$ according to Annex 2			
Edge distance	$c_{cr,N}$	[mm]	2 x $h_{ef}$			
	$c_{min}$	[mm]	$c_{min} = 2 \times h_{ef}$ ; if fire attack is from more than one side, the edge distance of the anchor has to be bigger than 300 mm.			

In absence of other national regulations the partial safety factor for resistance under fire exposure  $\gamma_{M,fi} = 1.0$  is recommended.

**Table 11: Characteristic values for shear loads under fire exposure in cracked and non-cracked concrete C20/25 to C50/60**

Anchor size		Ø 12				
Fire resistance duration	R	[min]	30	60	90	120
<b>Steel failure without lever arm</b>						
Characteristic resistance	$V_{Rk,s,fi}$	[kN]	4.6	3.4	2.2	1.6
<b>Steel failure with lever arm</b>						
Characteristic anchor resistance	$M^0_{Rk,s,fi}$	[Nm]	6	5	3	2
<b>Concrete pryout failure</b>						
The characteristic resistance $V_{Rk,cp,fi}$ may be determined by:						
$V_{Rk,cp,fi} = 2.0 \times N_{Rk,c,fi}$ (R30, R60, R90, R120)						
Determination of $N_{Rk,c,fi}$ analogue to $N_{Rk,c}$ , the value $N^0_{Rk,c,fi}$ according to table 10 has to be taken instead of $N^0_{Rk,c}$						
<b>Concrete edge failure</b>						
The initial value $V^0_{Rk,c,fi}$ of the characteristic resistance under fire exposure may be determined by:						
$V^0_{Rk,c,fi} = 0.25 \times V^0_{Rk,c}$ (R30, R60, R90) $V^0_{Rk,c,fi} = 0.20 \times V^0_{Rk,c}$ (R120)						
with the initial value $V^0_{Rk,c}$ of the characteristic resistance in cracked concrete C20/25 under normal temperature						

In absence of other national regulations the partial safety factor for resistance under fire exposure  $\gamma_{M,fi} = 1.0$  recommended.

**Würth Screw Anchor W-SA/S**

Characteristic values for tension and shear loads under fire exposure

**Annex 8**  
of European  
technical approval  
**ETA-09/0395**

**Installation instructions**

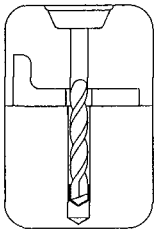

Use hammer drill or air drill with drill bit. Drill perpendicular to concrete surface.

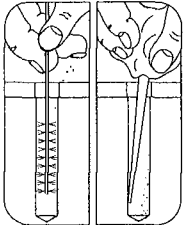

Cleaning of the hole of drilling dust

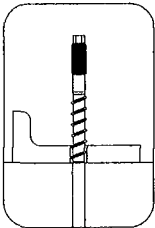

Apply the anchor

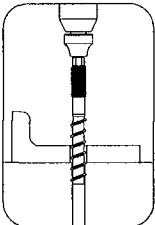

Installation with electric-screw-gun (size of tool holder < 3/4") or ratchet wrench. Anchor installation such that the embedment depth of the anchor in the concrete is not smaller than the value  $h_{nom}$  given in Annex 2 Table 2.

or

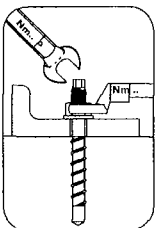
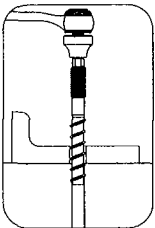

Assemble washer and hexagonnut. The maximum installation torque of the hexagonnut must not be exceeded. The add-on part can be installed with the max. torque by using a calibrated torque wrench.

**Würth Screw Anchor W-SA/S**

Installation instructions

**Annex 9**  
of European  
technical approval  
**ETA-09/0395**