

Deutsches Institut für Bautechnik

Anstalt des öffentlichen Rechts

Kolonnenstr. 30 L
10829 Berlin
Germany

Tel.: +49(0)30 787 30 0
Fax: +49(0)30 787 30 320
E-mail: dibt@dibt.de
Internet: www.dibt.de

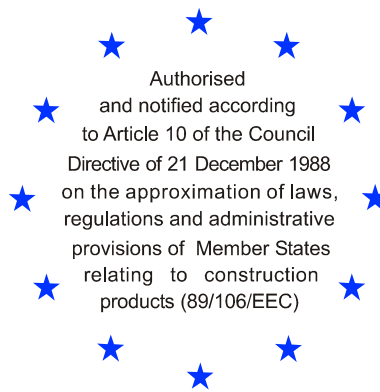

DIBt

Mitglied der EOTA
Member of EOTA

European Technical Approval ETA-09/0395

English translation prepared by DIBt - Original version in German language

Handelsbezeichnung <i>Trade name</i>	Würth Schraubanker W-SA/S <i>Würth Screw Anchor W-SA/S</i>
Zulassungsinhaber <i>Holder of approval</i>	Adolf Würth GmbH & Co. KG Reinhold-Würth-Straße 12-17 74653 Künzelsau DEUTSCHLAND
Zulassungsgegenstand und Verwendungszweck <i>Generic type and use of construction product</i>	Betonschraube Ø 12 aus galvanisch verzinktem Stahl zur Verankerung im Beton <i>Concrete screw Ø 12 made of galvanised steel for use in concrete</i>
Geltungsdauer: <i>Validity:</i>	vom <i>from</i> 19 January 2010 bis <i>to</i> 19 January 2015
Herstellwerk <i>Manufacturing plant</i>	Würth Herstellwerke W1, W15

Diese Zulassung umfasst
This Approval contains

13 Seiten einschließlich 6 Anhänge
13 pages including 6 annexes



Europäische Organisation für Technische Zulassungen
European Organisation for Technical Approvals

I LEGAL BASES AND GENERAL CONDITIONS

- 1 This European technical approval is issued by Deutsches Institut für Bautechnik in accordance with:
 - Council Directive 89/106/EEC of 21 December 1988 on the approximation of laws, regulations and administrative provisions of Member States relating to construction products¹, modified by Council Directive 93/68/EEC² and Regulation (EC) N° 1882/2003 of the European Parliament and of the Council³;
 - Gesetz über das In-Verkehr-Bringen von und den freien Warenverkehr mit Bauprodukten zur Umsetzung der Richtlinie 89/106/EWG des Rates vom 21. Dezember 1988 zur Angleichung der Rechts- und Verwaltungsvorschriften der Mitgliedstaaten über Bauprodukte und anderer Rechtsakte der Europäischen Gemeinschaften (Bauproduktengesetz - BauPG) vom 28. April 1998⁴, as amended by law of 31 October 2006⁵;
 - Common Procedural Rules for Requesting, Preparing and the Granting of European technical approvals set out in the Annex to Commission Decision 94/23/EC⁶.
- 2 Deutsches Institut für Bautechnik is authorized to check whether the provisions of this European technical approval are met. Checking may take place in the manufacturing plant. Nevertheless, the responsibility for the conformity of the products to the European technical approval and for their fitness for the intended use remains with the holder of the European technical approval.
- 3 This European technical approval is not to be transferred to manufacturers or agents of manufacturers other than those indicated on page 1, or manufacturing plants other than those indicated on page 1 of this European technical approval.
- 4 This European technical approval may be withdrawn by Deutsches Institut für Bautechnik, in particular pursuant to information by the Commission according to Article 5(1) of Council Directive 89/106/EEC.
- 5 Reproduction of this European technical approval including transmission by electronic means shall be in full. However, partial reproduction can be made with the written consent of Deutsches Institut für Bautechnik. In this case partial reproduction has to be designated as such. Texts and drawings of advertising brochures shall not contradict or misuse the European technical approval.
- 6 The European technical approval is issued by the approval body in its official language. This version corresponds fully to the version circulated within EOTA. Translations into other languages have to be designated as such.

1 Official Journal of the European Communities L 40, 11 February 1989, p. 12

2 Official Journal of the European Communities L 220, 30 August 1993, p. 1

3 Official Journal of the European Union L 284, 31 October 2003, p. 25

4 *Bundesgesetzblatt Teil I 1998*, p. 812

5 *Bundesgesetzblatt Teil I 2006*, p. 2407, 2416

6 Official Journal of the European Communities L 17, 20 January 1994, p. 34

II SPECIFIC CONDITIONS OF THE EUROPEAN TECHNICAL APPROVAL

1 Definition of the construction product and intended use

1.1 Definition of the construction product

The Würth Screw Anchor W-SA/S is an anchor made of galvanised steel of size Ø 12. The anchor is screwed into a predrilled cylindrical drill hole. The special thread of the anchor cuts an internal thread into the member while setting. The anchorage is characterised by mechanical interlock in the special thread.

An illustration of the product and intended use is given in Annex 1.

1.2 Intended use

The anchor is intended to be used for anchorages for which requirements for mechanical resistance and stability and safety in use in the sense of the Essential Requirements 1 and 4 of Council Directive 89/106 EEC shall be fulfilled and failure of anchorages made with these products would cause risk to human life and/or lead to considerable economic consequences.

The anchor may be used for anchorages with requirements related to resistance to fire.

The anchor is to be used only for anchorages subject to static or quasi-static loading in reinforced or unreinforced normal weight concrete of strength classes C20/25 at minimum and C50/60 at most according to EN 206:2000-12.

It may be anchored in cracked or non-cracked concrete.

The anchor may only be used in structures subject to dry internal conditions.

The provisions made in this European technical approval are based on an assumed working life of the anchor of 50 years. The indications given on the working life cannot be interpreted as a guarantee given by the producer, but are to be regarded only as a means for choosing the right products in relation to the expected economically reasonable working life of the works.

2 Characteristics of the product and methods of verification

2.1 Characteristics of the product

The anchor corresponds to the drawings and information given in Annexes 1 and 2. The characteristic material values, dimensions and tolerances of the anchor not indicated in Annexes 1 and 2 shall correspond to the respective values laid down in the technical documentation⁷ of this European technical approval.

Regarding the requirements concerning safety in case of fire it is assumed that the anchor meets the requirements of class A1 in relation to reaction to fire in accordance with the stipulations of the Commission decision 96/603/EC, amended by 2000/605/EC.

The characteristic values for the design of the anchorages are given in Annex 3 and 4.

⁷ The technical documentation of this European technical approval is deposited at the Deutsches Institut für Bautechnik and, as far as relevant for the tasks of the approved bodies involved in the attestation of conformity procedure, is handed over to the approved bodies.

The characteristic values for the design of anchorages regarding resistance to fire are given in the Annex 5. They are valid for use in a system that is required to provide a specific fire resistance class.

Each anchor shall be marked with the works symbol, the anchor type, number of producer, the length of the anchor L_s and the length of the special thread L_g according to Annex 1.

2.2 Methods of verification

The assessment of fitness of the anchor for the intended use in relation to the requirements for mechanical resistance and stability and safety in use in the sense of the Essential Requirements 1 and 4 has been made in accordance with the "Guideline for European technical approval of Metal Anchors for use in concrete", Part 1 "Anchors in general" and Part 3 "Undercut anchors", on the basis of Option 1.

The assessment of the anchor for the intended use in relation to the requirements for resistance to fire has been made in accordance with the Technical Report TR 020 "Evaluation of anchorages in concrete concerning resistance to fire".

In addition to the specific clauses relating to dangerous substances contained in this European technical approval, there may be other requirements applicable to the products falling within its scope (e.g. transposed European legislation and national laws, regulations and administrative provisions). In order to meet the provisions of the Construction Products Directive, these requirements need also to be complied with, when and where they apply.

3 Evaluation and attestation of conformity and CE marking

3.1 System of attestation of conformity

According to the decision 96/582/EG of the European Commission⁸ the system 2(i) (referred to as system 1) of attestation of conformity applies.

This system of attestation of conformity is defined as follows:

System 1: Certification of the conformity of the product by an approved certification body on the basis of:

- (a) Tasks for the manufacturer:
 - (1) factory production control;
 - (2) further testing of samples taken at the factory by the manufacturer in accordance with a prescribed control plan;
- (b) Tasks for the approved body:
 - (3) initial type-testing of the product;
 - (4) initial inspection of factory and of factory production control;
 - (5) continuous surveillance, assessment and approval of factory production control.

Note: Approved bodies are also referred to as "notified bodies".

⁸ Official Journal of the European Communities L 254 of 08.10.1996.

3.2 Responsibilities

3.2.1 Tasks of the manufacturer

3.2.1.1 Factory production control

The manufacturer shall exercise permanent internal control of production. All the elements, requirements and provisions adopted by the manufacturer shall be documented in a systematic manner in the form of written policies and procedures, including records of results performed. This production control system shall insure that the product is in conformity with this European technical approval.

The manufacturer may only use initial / raw / constituent materials stated in the technical documentation of this European technical approval.

The factory production control shall be in accordance with the control plan which is part of the technical documentation of this European technical approval. The control plan is laid down in the context of the factory production control system operated by the manufacturer and deposited at Deutsches Institut für Bautechnik.⁹

The results of factory production control shall be recorded and evaluated in accordance with the provisions of the control plan.

3.2.1.2 Other tasks of manufacturer

The manufacturer shall, on the basis of a contract, involve a body which is approved for the tasks referred to in section 3.1 in the field of anchors in order to undertake the actions laid down in section 3.2.2. For this purpose, the control plan referred to in sections 3.2.1.1 and 3.2.2 shall be handed over by the manufacturer to the approved body involved.

The manufacturer shall make a declaration of conformity, stating that the construction product is in conformity with the provisions of this European technical approval.

3.2.2 Tasks of approved bodies

The approved body shall perform the

- initial type-testing of the product,
- initial inspection of factory and of factory production control,
- continuous surveillance, assessment and approval of factory production control,

in accordance with the provisions laid down in the control plan.

The approved body shall retain the essential points of its actions referred to above and state the results obtained and conclusions drawn in a written report.

The approved certification body involved by the manufacturer shall issue an EC certificate of conformity of the factory production control stating the conformity with the factory production control of this European technical approval.

In cases where the provisions of the European technical approval and its control plan are no longer fulfilled the certification body shall withdraw the certificate of conformity and inform Deutsches Institut für Bautechnik without delay.

⁹ The control plan is a confidential part of the documentation of the European technical approval, but not published together with the European technical approval and only handed over to the approved body involved in the procedure of attestation of conformity.
See section 3.2.2.

3.3 CE marking

The CE marking shall be affixed on each packaging of the anchors. The letters "CE" shall be followed by the identification number of the approved certification body, where relevant, and be accompanied by the following additional information:

The CE marking shall be affixed on each packaging of the anchor. The letters "CE" shall be followed by the identification number of the approved certification body, where relevant, and be accompanied by the following additional information:

- the name and address of the producer (legal entity responsible for the manufacturer),
- the last two digits of the year in which the CE marking was affixed,
- the number of the EC certificate of conformity for the product,
- the number of the European technical approval,
- the number of the guideline for European technical approval,
- use category (ETAG 001-1 Option 1),
- size.

4 Assumptions under which the fitness of the product for the intended use was favourably assessed

4.1 Manufacturing

The European technical approval is issued for the product on the basis of agreed data/information, deposited with Deutsches Institut für Bautechnik, which identifies the product that has been assessed and judged. Changes to the product or production process, which could result in this deposited data/information being incorrect, should be notified to Deutsches Institut für Bautechnik before the changes are introduced. Deutsches Institut für Bautechnik will decide whether or not such changes affect the European technical approval and consequently the validity of the CE marking on the basis of the European technical approval and if so whether further assessment or alterations to the European technical approval shall be necessary.

4.2 Design of anchorages

The fitness of the anchor for the intended use is given under the following conditions:

The anchorages are designed in accordance with the "Guideline for European technical approval of Metal Anchors for Use in Concrete", Annex C, Method A under the responsibility of an engineer experienced in anchorages and concrete work.

Verifiable calculation notes and drawings are prepared taking account of the loads to be anchored.

The position of the anchor is indicated on the design drawings (e.g. position of the anchor relative to reinforcement or to supports, in cracked or non-cracked concrete, etc.).

The design of anchorages under fire exposure has to consider the conditions given in the Technical Report TR 020 "Evaluation of anchorages in concrete concerning resistance to fire". The relevant characteristic anchor values are given in Annex 5. The design method covers anchors with a fire attack from one side only. If the fire attack is from more than one side, the design method may be taken only, if the edge distance of the anchor is $c \geq 300$ mm.

4.3 Installation of anchors

The fitness for use of the anchor can only be assumed if the following conditions of installation are met:

- Anchor installation carried out by appropriately qualified personnel under the supervision of the person responsible for technical matters on site,
- Use of the anchor only as supplied by the manufacturer,
- Anchor installation in accordance with the manufacturer's specifications and drawings,
- Checks before placing the anchor, to ensure that the characteristic values of the base material in which the anchor is to be placed, is identical with the values, which the characteristic loads apply,
- Check of the concrete being well compacted, e.g. without significant voids,
- Edge distances and spacings not less than the specified values without minus tolerances,
- Placing drill holes without damaging the reinforcement,
- In case of aborted hole: new drilling at a minimum distance away of twice the depth of the aborted hole or smaller distance if the aborted hole is filled with high strength mortar and if under shear or oblique tension load it is not the direction of the load application,
- Cleaning of the hole of drilling dust,
- Anchor installation such that the embedment depth of the anchor in the concrete is not smaller than the value h_{nom} given in Annex 2, Table 2,
- The maximum installation torque of the hexagonnut given in Annex 2, Table 2 must not be exceeded.
- The anchor may only be used once.

5 Responsibility of the manufacturer

The manufacturer is responsible to ensure that the information on the specific conditions according to 1 and 2 including Annexes referred to 4.2 and 4.3 is given to those who are concerned. This information may be made by reproduction of the respective parts of the European technical approval. In addition, all installation data shall be shown clearly on the packaging and/or on an enclosed instruction sheet, preferably using illustrations.

The minimum data required are:

- Drill bit diameter,
- Size of the anchor,
- Maximum thickness of the fixture,
- Minimum embedment depth,
- Minimum hole depth,
- Information on the installation procedure, including cleaning of the hole, preferably by means of an illustration,
- Reference to any special installation equipment needed,
- Identification of the manufacturing batch.

All data shall be presented in a clear and explicit form.

Dipl.-Ing. Georg Feistel
Head of Division Construction Engineering
of Deutsches Institut für Bautechnik
Berlin, 19 January 2010

beglaubigt
Lange

Intended use

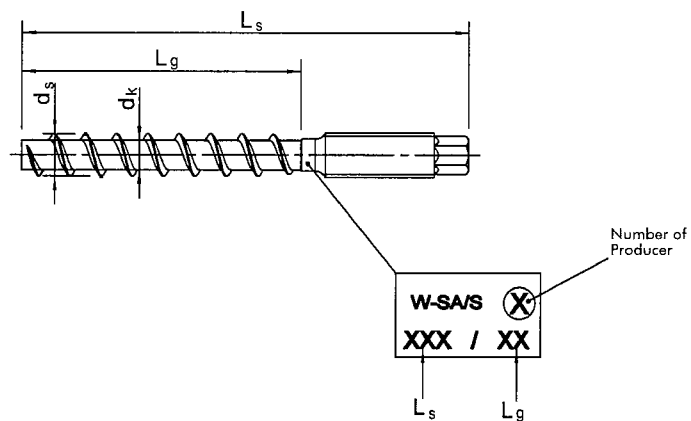
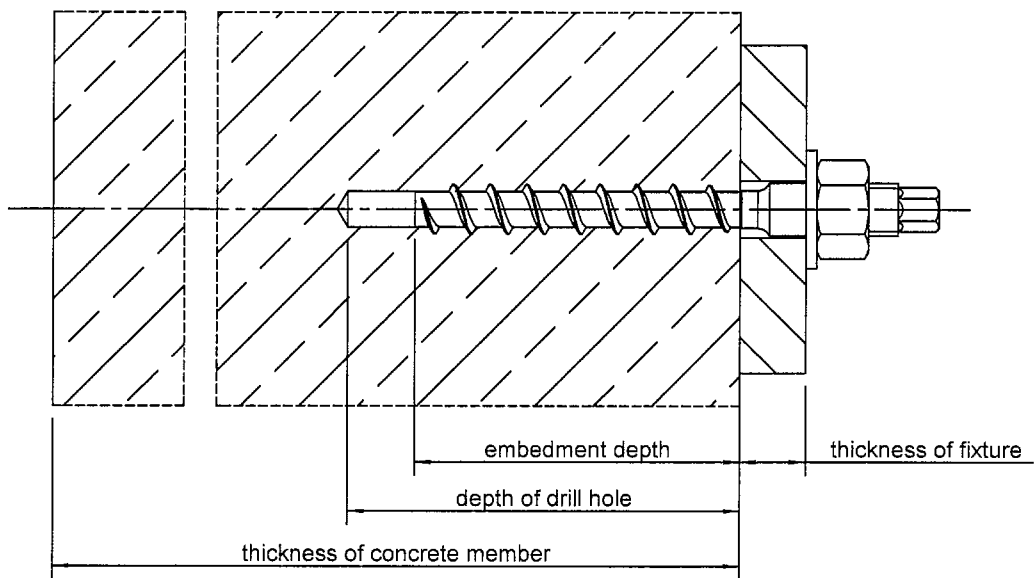

Table 1: Dimensions and materials

Anchor size			$\varnothing 12$
Length of screw	$L_s \geq$	[mm]	90
	$L_s \leq$	[mm]	300
Length of thread	$L_g \geq$	[mm]	75
	$L_g \leq$	[mm]	200
Bolt diameter	d_k	[mm]	9.15
Thread diameter	d_s	[mm]	12.25
Material			Zinc plated steel acc. to EN 10263-4

Würth Screw Anchor W-SA/S

Product and intended use
Dimensions and materials

Annex 1
of European
technical approval
ETA-09/0395

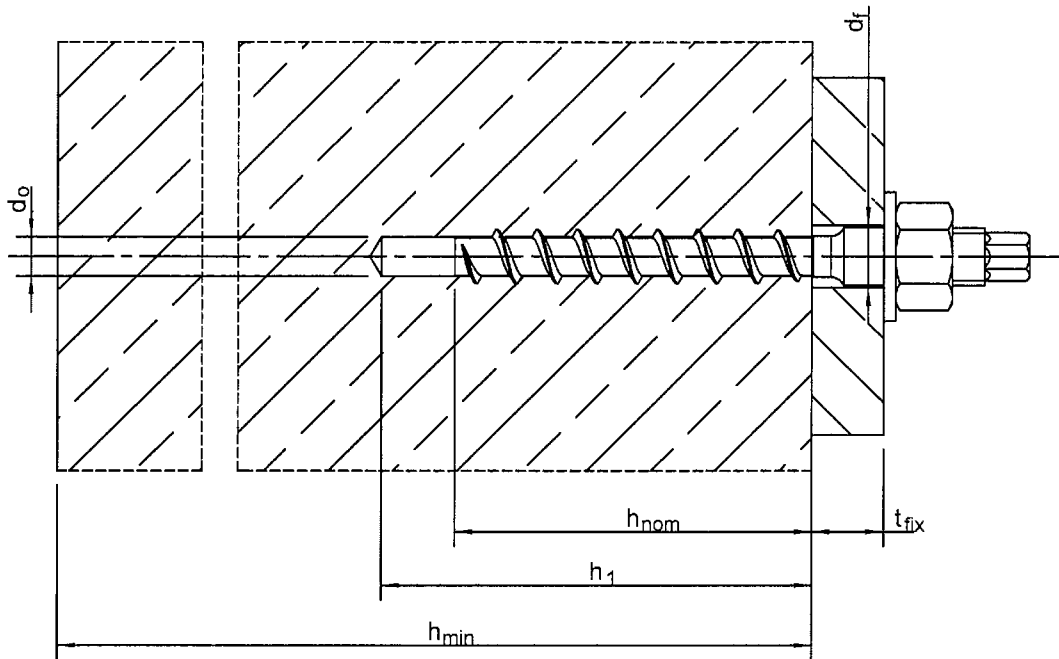

Table 2: Installation parameters

Anchor size			Ø 12
Nominal drill diameter	d_0	[mm]	10.0
Cutting diameter of the drill bit	$d_{cut} \leq$	[mm]	10.45
Depth of drill hole	$h_1 \geq$	[mm]	85
Embedment depth	$h_{nom} \geq$	[mm]	75
Diameter of clearance hole in the fixture	$d_f \leq$	[mm]	14.0
Installation torque of the hexagonnut		[Nm]	35

Table 3: Minimum thickness of concrete member, minimum spacing and edge distance

Anchor size			Ø 12
Minimum thickness of the concrete member	h_{min}	[mm]	120
Cracked concrete and non-cracked concrete			
Minimum spacing	s_{min}	[mm]	60
Minimum edge distance	c_{min}	[mm]	50

Würth Screw Anchor W-SA/S

Installation parameters,
Minimum thickness of concrete member,
Minimum spacing and edge distance

Annex 2
of European
technical approval
ETA-09/0395

Table 4: Design method A, characteristic values for tension loads

Anchor size		$\varnothing 12$	
Steel failure			
Characteristic resistance	$N_{Rk,s}$	[kN]	51
Partial safety factor	γ_{Ms} ¹⁾	[-]	1.4
Pullout			
Characteristic resistance in cracked concrete C20/25	$N_{Rk,p}$	[kN]	12
Characteristic resistance in non-cracked concrete C20/25	$N_{Rk,p}$	[kN]	16
Increasing factor for $N_{Rk,p}$ in cracked and non-cracked concrete	ψ_c	C30/37	1.22
		C40/50	1.41
		C50/60	1.55
Partial safety factor	γ_{Mp} ¹⁾²⁾	[-]	1.8
Concrete cone failure			
Effective anchorage depth	h_{ef}	[mm]	56
Spacing	$s_{cr,N}$	[mm]	3 h_{ef}
Edge distance	$c_{cr,N}$	[mm]	1.5 h_{ef}
Partial safety factor	γ_{Mc} ¹⁾²⁾	[-]	1.8
Splitting failure			
Spacing	$s_{cr,sp}$	[mm]	3 h_{ef}
Edge distance	$c_{cr,sp}$	[mm]	1.5 h_{ef}
Partial safety factor	γ_{Msp} ¹⁾²⁾	[-]	1.8

1) in absence of other national regulations

2) the installation safety factor $\gamma_2 = 1.2$ is included**Table 5: Displacements under tension loads**

Anchor size		$\varnothing 12$	
Tension load in cracked and non-cracked concrete	N	[kN]	4.8
Displacement	δ_{N0}	[mm]	0.2
	$\delta_{N\infty}$	[mm]	1.0

Würth Screw Anchor W-SA/SDesign method A,
Characteristic values for tension loads,
Displacements**Annex 3**
of European
technical approval
ETA-09/0395

Table 6: Design method A, characteristic values for shear loads

Anchor size		$\varnothing 12$	
Steel failure without lever arm			
Characteristic resistance	$V_{Rk,s}$	[kN]	25
Partial safety factor	γ_{Ms} ¹⁾	[-]	1.25
Steel failure with lever arm			
Characteristic anchor resistance	$M_{Rk,s}^0$	[Nm]	68
Partial safety factor	γ_{Ms} ¹⁾	[-]	1.25
Concrete pryout failure			
Factor in equation 5.6 of ETAG, Annex C, section 5.2.3.3	k	[-]	2.0
Partial safety factor	γ_{Mcp} ¹⁾	[-]	1.5
Concrete edge failure			
Effective length of the anchor in shear loading	l_f	[mm]	56
Effective diameter of the anchor	d_{nom}	[mm]	9
Partial safety factor	γ_{Mc} ¹⁾²⁾	[-]	1.5

¹⁾ in absence of other national regulations

²⁾ the installation safety factor $\gamma_2 = 1.0$ is included

Table 7: Displacements under shear loads

Anchor size		$\varnothing 12$	
Shear load in cracked and non-cracked concrete	V	[kN]	14.3
Displacement	δ_{V0}	[mm]	3.6
	$\delta_{V\infty}$	[mm]	5.4

Würth Screw Anchor W-SA/S

Design method A,
Characteristic values for shear loads,
Displacements

Annex 4
of European
technical approval
ETA-09/0395

Table 8: Characteristic values for tension loads under fire exposure in cracked or non-cracked concrete

Anchor size			Ø 12			
Fire resistance duration	R	[min]	30	60	90	120
Steel failure						
Characteristic resistance	$N_{Rk,s,fi}$	[kN]	4.6	3.4	2.2	1.6
Pullout						
Characteristic resistance in concrete C20/25 to C50/60	$N_{Rk,p,fi}$	[kN]	3.0	3.0	3.0	2.4
Concrete cone failure						
Characteristic resistance in concrete C20/25 to C50/60	$N_{Rk,c,fi}$	[kN]	4.2	4.2	4.2	3.3
Spacing	$s_{cr,N}$	[mm]	4 x h_{ef}			
	s_{min}	[mm]	s_{min} according to Annex 2			
Edge distance	$c_{cr,N}$	[mm]	2 x h_{ef}			
	c_{min}	[mm]	$c_{min} = 2 \times h_{ef}$; if fire attack is from more than one side, the edge distance of the anchor has to be bigger than 300 mm.			

In absence of other national regulations the partial safety factor for resistance under fire exposure $\gamma_{M,fi} = 1.0$ is recommended.

Table 9: Characteristic values for shear loads under fire exposure in cracked or non-cracked concrete

Anchor size			Ø 12			
Fire resistance duration	R	[min]	30	60	90	120
Steel failure without lever arm						
Characteristic resistance	$V_{Rk,s,fi}$	[kN]	4.6	3.4	2.2	1.6
Steel failure with lever arm						
Characteristic anchor resistance	$M^0_{Rk,s,fi}$	[Nm]	6	5	3	2
Concrete pryout failure In equation (5.6) of ETAG 001, Annex C. 5.2.3.3 the k-factor 2.0 and the relevant values of $N^0_{Rk,c,fi}$ of table 8 have to be considered						
Concrete edge failure The initial value $V^0_{Rk,c,fi}$ of the characteristic resistance in concrete C20/25 to C50/60 under fire exposure may be determined by:						
$V^0_{Rk,c,fi} = 0.25 \times V^0_{Rk,c} \text{ (R30, R60, R90)}$ $V^0_{Rk,c,fi} = 0.20 \times V^0_{Rk,c} \text{ (R120)}$						
with $V^0_{Rk,c}$ initial value of the characteristic resistance in cracked concrete C20/25 under normal temperature						

In absence of other national regulations the partial safety factor for resistance under fire exposure $\gamma_{M,fi} = 1.0$ recommended.

Würth Screw Anchor W-SA/S

Characteristic values for tension and shear loads under fire exposure

Annex 5
of European
technical approval
ETA-09/0395

Installation instructions

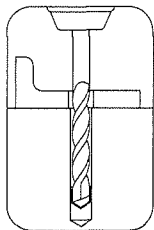

Use hammer drill or air drill with drill bit. Drill perpendicular to concrete surface.

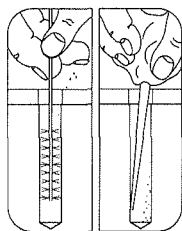

Cleaning of the hole of drilling dust

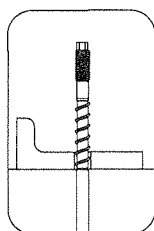

Apply the anchor

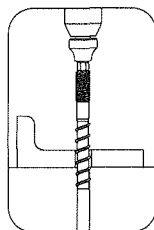

Installation with electric-screw-gun (size of tool holder < 3/4") or ratchet wrench. Anchor installation such that the embedment depth of the anchor in the concrete is not smaller than the value h_{nom} given in Annex 2 Table 2.

or

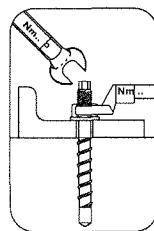
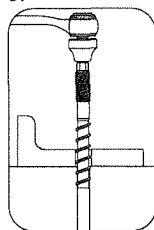

Assemble washer and hexagonnut. The maximum installation torque of the hexagonnut must not be exceeded. The add-on part can be installed with the max. torque by using a calibrated torque wrench.

Würth Screw Anchor W-SA/S

Installation instructions

Annex 6
of European
technical approval
ETA-09/0395