

# Deutsches Institut für Bautechnik

Anstalt des öffentlichen Rechts

Kolonnenstr. 30 L  
10829 Berlin  
Germany

Tel.: +49(0)30 787 30 0  
Fax: +49(0)30 787 30 320  
E-mail: [dibt@dibt.de](mailto:dibt@dibt.de)  
Internet: [www.dibt.de](http://www.dibt.de)



# DIBt

Mitglied der EOTA  
*Member of EOTA*

## European Technical Approval ETA-09/0157

English translation prepared by DIBt - Original version in German language

Handelsbezeichnung <i>Trade name</i>	BTI Simplexanker BAZ <i>BTI simplex anchor BAZ</i>
Zulassungsinhaber <i>Holder of approval</i>	BTI Befestigungstechnik GmbH Salzstraße 51 74653 Ingelfingen DEUTSCHLAND
Zulassungsgegenstand und Verwendungszweck <i>Generic type and use of construction product</i>	Kraftkontrolliert spreizender Dübel in den Größen M8, M10, M12, M16, M20 und M24 zur Verankerung im Beton <i>Torque controlled expansion anchor of sizes M8, M10, M12, M16, M20 and M24 for use in concrete</i>
Geltungsdauer: <i>Validity:</i>	vom <i>from</i> 26 July 2010 bis <i>to</i> 9 December 2013
Herstellwerk <i>Manufacturing plant</i>	BTI Herstellwerk 1

Diese Zulassung umfasst  
*This Approval contains*

16 Seiten einschließlich 8 Anhänge  
*16 pages including 8 annexes*

Diese Zulassung ersetzt  
*This Approval replaces*

ETA-09/0157 mit Geltungsdauer vom 12.05.2009 bis 09.12.2013  
*ETA-09/0157 with validity from 12.05.2009 to 09.12.2013*



Europäische Organisation für Technische Zulassungen  
European Organisation for Technical Approvals

## I LEGAL BASES AND GENERAL CONDITIONS

- 1 This European technical approval is issued by Deutsches Institut für Bautechnik in accordance with:
  - Council Directive 89/106/EEC of 21 December 1988 on the approximation of laws, regulations and administrative provisions of Member States relating to construction products<sup>1</sup>, modified by Council Directive 93/68/EEC<sup>2</sup> and Regulation (EC) N° 1882/2003 of the European Parliament and of the Council<sup>3</sup>;
  - Gesetz über das In-Verkehr-Bringen von und den freien Warenverkehr mit Bauprodukten zur Umsetzung der Richtlinie 89/106/EWG des Rates vom 21. Dezember 1988 zur Angleichung der Rechts- und Verwaltungsvorschriften der Mitgliedstaaten über Bauprodukte und anderer Rechtsakte der Europäischen Gemeinschaften (Bauproduktengesetz - BauPG) vom 28. April 1998<sup>4</sup>, as amended by law of 31 October 2006<sup>5</sup>;
  - Common Procedural Rules for Requesting, Preparing and the Granting of European technical approvals set out in the Annex to Commission Decision 94/23/EC<sup>6</sup>;
  - Guideline for European technical approval of "Metal anchors for use in concrete - Part 2: Torque controlled expansion anchors ", ETAG 001-02.
- 2 Deutsches Institut für Bautechnik is authorized to check whether the provisions of this European technical approval are met. Checking may take place in the manufacturing plant. Nevertheless, the responsibility for the conformity of the products to the European technical approval and for their fitness for the intended use remains with the holder of the European technical approval.
- 3 This European technical approval is not to be transferred to manufacturers or agents of manufacturers other than those indicated on page 1, or manufacturing plants other than those indicated on page 1 of this European technical approval.
- 4 This European technical approval may be withdrawn by Deutsches Institut für Bautechnik, in particular pursuant to information by the Commission according to Article 5(1) of Council Directive 89/106/EEC.
- 5 Reproduction of this European technical approval including transmission by electronic means shall be in full. However, partial reproduction can be made with the written consent of Deutsches Institut für Bautechnik. In this case partial reproduction has to be designated as such. Texts and drawings of advertising brochures shall not contradict or misuse the European technical approval.
- 6 The European technical approval is issued by the approval body in its official language. This version corresponds fully to the version circulated within EOTA. Translations into other languages have to be designated as such.

---

1 Official Journal of the European Communities L 40, 11 February 1989, p. 12

2 Official Journal of the European Communities L 220, 30 August 1993, p. 1

3 Official Journal of the European Union L 284, 31 October 2003, p. 25

4 *Bundesgesetzblatt Teil I 1998*, p. 812

5 *Bundesgesetzblatt Teil I 2006*, p.2407, 2416

6 Official Journal of the European Communities L 17, 20 January 1994, p. 34

## II SPECIFIC CONDITIONS OF THE EUROPEAN TECHNICAL APPROVAL

### 1 Definition of the construction product and intended use

#### 1.1 Definition of the product

The BTI simplex anchor BAZ in the range of M8, M10, M12, M16, M20 and M24 is an anchor made of galvanised steel (type BAZ), stainless steel (type BAZ A4) or high corrosion steel (type BAZ C) which is placed into a drilled hole and anchored by torque-controlled expansion.

An illustration of the product and intended use is given in Annex 1.

#### 1.2 Intended use

The anchor is intended to be used for anchorages for which requirements for mechanical resistance and stability and safety in use in the sense of the Essential Requirements 1 and 4 of Council Directive 89/106 EEC shall be fulfilled and failure of anchorages made with these products would cause risk to human life and/or lead to considerable economic consequences.

The anchor may be used for anchorages with requirements related to resistance to fire.

The anchor is to be used only for anchorages subject to static or quasi-static loading in reinforced or unreinforced normal weight concrete of strength classes C20/25 at minimum and C50/60 at most according to EN 206:2000-12.

The anchor may be used in cracked and non-cracked concrete.

##### BTI simplex anchor BAZ made of galvanised steel:

The anchor may only be used in structures subject to dry internal conditions.

##### BTI simplex anchor BAZ A4 made of stainless steel:

The anchor made of stainless steel A4 may be used in structures subject to dry internal conditions and also in structures subject to external atmospheric exposure (including industrial and marine environment), or exposure in permanently damp internal conditions, if no particular aggressive conditions exist. Such particular aggressive conditions are e.g. permanent, alternating immersion in seawater or the splash zone of seawater, chloride atmosphere of indoor swimming pools or atmosphere with extreme chemical pollution (e.g. in desulphurization plants or road tunnels where de-icing materials are used).

##### BTI simplex anchor BAZ C made of high corrosion resistant steel:

The anchor made of high corrosion resistant steel may be used in structures subject to dry internal conditions and also in structures subject to external atmospheric exposure, in permanently damp internal conditions or in other particular aggressive conditions. Such particular aggressive conditions are e.g. permanent, alternating immersion in seawater or the splash zone of seawater, chloride atmosphere of indoor swimming pools or atmosphere with chemical pollution (e.g. in desulphurization plants or road tunnels where de-icing materials are used).

The provisions made in this European technical approval are based on an assumed working life of the anchor of 50 years. The indications given on the working life cannot be interpreted as a guarantee given by the producer, but are to be regarded only as a means for choosing the right products in relation to the expected economically reasonable working life of the works.

## **2 Characteristics of the product and methods of verification**

### **2.1 Characteristics of the product**

The anchor corresponds to the drawings and provisions given in Annex 2 and 3. The characteristic material values, dimensions and tolerances of the anchor not given in Annex 2 and 3 shall correspond to the respective values laid down in the technical documentation<sup>7</sup> of this European technical approval.

Regarding the requirements concerning safety in case of fire it is assumed that the anchor meets the requirements of class A1 in relation to reaction to fire in accordance with the stipulations of the Commission decision 96/603/EC, amended by 2000/605/EC.

The characteristic values for the design of anchorages are given in Annexes 5 and 6.

The characteristic values for the design of anchorages regarding resistance to fire are given in Annexes 7 and 8. They are valid for use in a system that is required to provide a specific fire resistance class.

Each anchor is marked with the identifying mark of the producer, the anchor type, the thread size and the maximum thickness of fixture according to Annex 2. Each anchor made of stainless steel A4 is marked with the letter "A4" and each anchor made of high corrosion resistant steel is marked with the letters "C".

The anchor shall only be packaged and supplied as a complete unit.

### **2.2 Methods of verification**

The assessment of fitness of the anchor for the intended use in relation to the requirements for mechanical resistance and stability and safety in use in the sense of the Essential Requirements 1 and 4 has been made in accordance with the "Guideline for European technical approval of Metal Anchors for Use in Concrete" ETAG 001, Part 1 "Anchors in general" and Part 2 "Torque-controlled expansion anchors", on the basis of Option 1.

The assessment of the anchor for the intended use in relation to the requirements for resistance to fire has been made in accordance with the Technical Report TR 020 "Evaluation of anchorages in concrete concerning resistance to fire".

In addition to the specific clauses relating to dangerous substances contained in this European technical approval, there may be other requirements applicable to the products falling within its scope (e.g. transposed European legislation and national laws, regulations and administrative provisions). In order to meet the provisions of the Construction Products Directive, these requirements need also to be complied with, when and where they apply.

---

<sup>7</sup> The technical documentation of this European technical approval is deposited at the Deutsches Institut für Bautechnik and, as far as relevant for the tasks of the approved bodies involved in the attestation of conformity procedure, is handed over to the approved bodies.

### **3 Evaluation and attestation of conformity and CE marking**

#### **3.1 System of attestation of conformity**

According to the decision 96/582/EG of the European Commission<sup>8</sup> the system 2(i) (referred to as system 1) of attestation of conformity applies.

This system of attestation of conformity is defined as follows:

System 1: Certification of the conformity of the product by an approved certification body on the basis of:

- (a) Tasks for the manufacturer:
  - (1) factory production control;
  - (2) further testing of samples taken at the factory by the manufacturer in accordance with a prescribed control plan;
- (b) Tasks for the approved body:
  - (3) initial type-testing of the product;
  - (4) initial inspection of factory and of factory production control;
  - (5) continuous surveillance, assessment and approval of factory production control.

Note: Approved bodies are also referred to as "notified bodies".

#### **3.2 Responsibilities**

##### **3.2.1 Tasks for the manufacturer**

###### **3.2.1.1 Factory production control**

The manufacturer shall exercise permanent internal control of production. All the elements, requirements and provisions adopted by the manufacturer shall be documented in a systematic manner in the form of written policies and procedures, including records of results performed. This production control system shall insure that the product is in conformity with this European technical approval.

The manufacturer may only use initial/raw/constituent materials stated in the technical documentation of this European technical approval.

The factory production control shall be in accordance with the control plan which is part of the technical documentation of this European technical approval. The control plan is laid down in the context of the factory production control system operated by the manufacturer and deposited with Deutsches Institut für Bautechnik.<sup>9</sup>

The results of factory production control shall be recorded and evaluated in accordance with the provisions of the control plan.

###### **3.2.1.2 Other tasks for the manufacturer**

The manufacturer shall, on the basis of a contract, involve a body which is approved for the tasks referred to in section 3.1 in the field of anchors in order to undertake the actions laid down in section 3.2.2 For this purpose, the control plan referred to in sections 3.2.1.1 and 3.2.2 shall be handed over by the manufacturer to the approved body involved.

The manufacturer shall make a declaration of conformity, stating that the construction product is in conformity with the provisions of this European technical approval.

---

<sup>8</sup> Official Journal of the European Communities L 254 of 08.10.1996.

<sup>9</sup> The control plan is a confidential part of the European technical approval and only handed over to the approved body involved in the procedure of attestation of conformity. See section 3.2.2.

### 3.2.2 Tasks for the approved bodies

The approved body shall perform the

- initial type-testing of the product,
- initial inspection of factory and of factory production control,
- continuous surveillance, assessment and approval of factory production control,

in accordance with the provisions laid down in the control plan.

The approved body shall retain the essential points of its actions referred to above and state the results obtained and conclusions drawn in a written report.

The approved certification body involved by the manufacturer shall issue an EC certificate of conformity of the product stating the conformity with the provisions of this European technical approval.

In cases where the provisions of the European technical approval and its control plan are no longer fulfilled the certification body shall withdraw the certificate of conformity and inform Deutsches Institut für Bautechnik without delay.

## 3.3 CE marking

The CE marking shall be affixed on each packaging of anchors. The letters "CE" shall be followed by the identification number of the approved certification body, where relevant, and be accompanied by the following additional information:

- the name and address of the holder of the approval (legal entity responsible for the manufacturer),
- the last two digits of the year in which the CE marking was affixed,
- the number of the EC certificate of conformity for the product,
- the number of the European technical approval,
- the number of the guideline for European technical approval,
- use category (ETAG 001-1, Option 1),
- size.

## 4 Assumptions under which the fitness of the product for the intended use was favourably assessed

### 4.1 Manufacturing

The European technical approval is issued for the product on the basis of agreed data/information, deposited with Deutsches Institut für Bautechnik, which identifies the product that has been assessed and judged. Changes to the product or production process, which could result in this deposited data/information being incorrect, should be notified to Deutsches Institut für Bautechnik before the changes are introduced. Deutsches Institut für Bautechnik will decide whether or not such changes affect the European technical approval and consequently the validity of the CE marking on the basis of the European technical approval and if so whether further assessment or alterations to the European technical approval shall be necessary.

## 4.2 Design of anchorages

The fitness of the anchor for the intended use is given under the following conditions:

The anchorages are designed in accordance with the "Guideline for European technical approval of Metal Anchors for Use in Concrete", Annex C, Method A, for torque controlled expansion anchors under the responsibility of an engineer experienced in anchorages and concrete work.

Verifiable calculation notes and drawings are taking account of the loads to be anchored.

The position of the anchor is indicated on the design drawings (e.g. position of the anchor relative to reinforcement or to supports).

The design of anchorages under fire exposure has to consider the conditions given in the Technical Report TR 020 "Evaluation of anchorages in concrete concerning resistance to fire". The relevant characteristic anchor values are given in Annexes 7 and 8. The design method covers anchors with a fire attack from one side only. If the fire attack is from more than one side, the design method may be taken only, if the edge distance of the anchor is  $c \geq 300$  mm.

## 4.3 Installation of anchors

The fitness for use of the anchor can only be assumed if the anchor is installed as follows:

- Anchor installation carried out by appropriately qualified personnel and under the supervision of the person responsible for technical matters of the site,
- Use of the anchor only as supplied by the manufacturer without exchanging the components of an anchor,
- Anchor installation in accordance with the manufacturer's specifications and drawings and using the appropriate tools,
- Checks before placing the anchor to ensure that the strength class of the concrete in which the anchor is to be placed is in the range given and is not lower than that of the concrete to which the characteristic loads apply,
- Check of concrete being well compacted, e.g. without significant voids,
- Edge distances and spacings not less than the specified values without minus tolerances,
- Positioning of the drill holes without damaging the reinforcement,
- In case of aborted hole: new drilling at a minimum distance away of twice the depth of the aborted hole or smaller distance if the aborted drill hole is filled with high strength mortar and if under shear or oblique tension load it is not in the direction of load application,
- Cleaning of the hole of drilling dust,
- Anchor installation such that the effective anchorage depth is complied with. This compliance is ensured, if the exist thickness of fixture is not greater than the maximum thickness of fixture marked on the anchor,
- Application of the torque moment given in Annex 4 using a calibrated torque wrench.

## 5 Responsibility of the manufacturer

The manufacturer is responsible to ensure that the information on the specific conditions according to 1 and 2 including Annexes referred to as well as sections 4.2 and 4.3 is given to those who are concerned. This information may be made by reproduction of the respective parts of the European technical approval. In addition all installation data shall be shown clearly on the package and/or on an enclosed instruction sheet, preferably using illustration(s).

The minimum data required are:

- Diameter of drill bit,
- Thread diameter,
- Maximum thickness of the fixture,
- Minimum effective anchorage depth,
- Minimum hole depth,
- Torque moment,
- Information on the installation procedure, including cleaning of the hole, preferably by means of an illustration,
- Reference to any special installation equipment needed,
- Identification of the manufacturing batch.

All data shall be presented in a clear and explicit form.

Dipl.-Ing. Georg Feistel  
Head of Division construction Engineering  
of Deutsches Institut für Bautechnik  
Berlin, 26 July 2010

*beglaubigt*  
Tempel



Cone bolt manufactured by cold – forming:

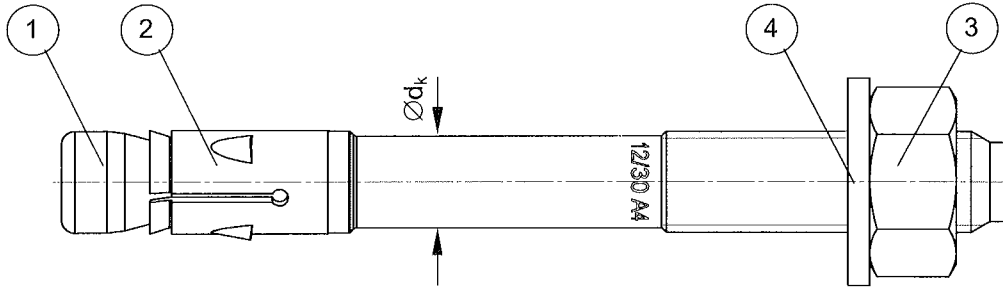

Cone bolt manufactured by metal - cutting::

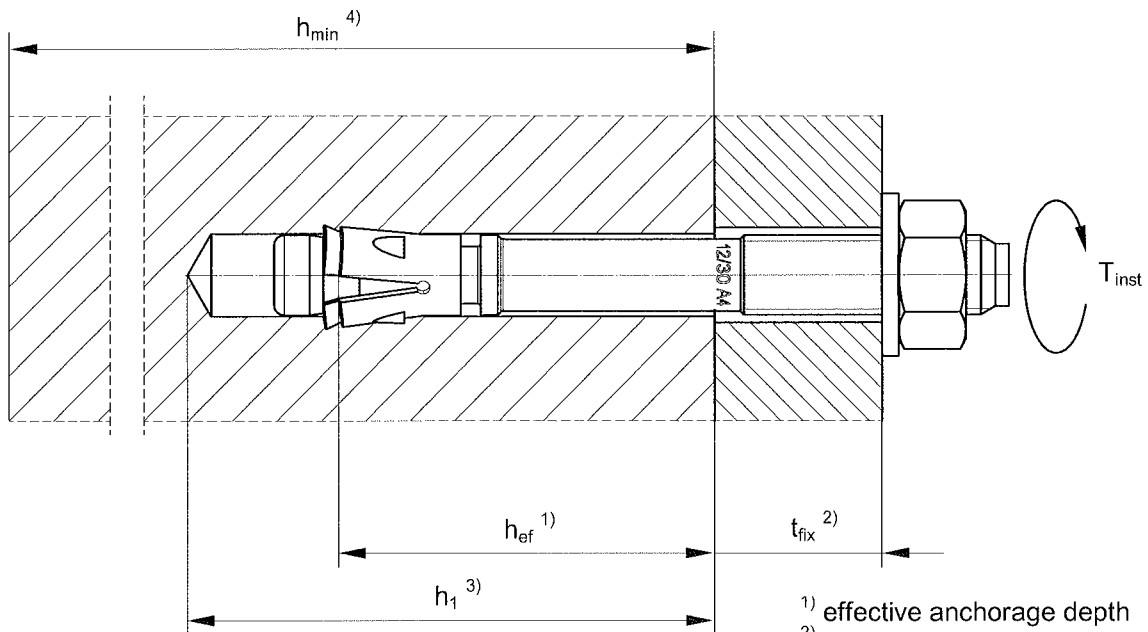
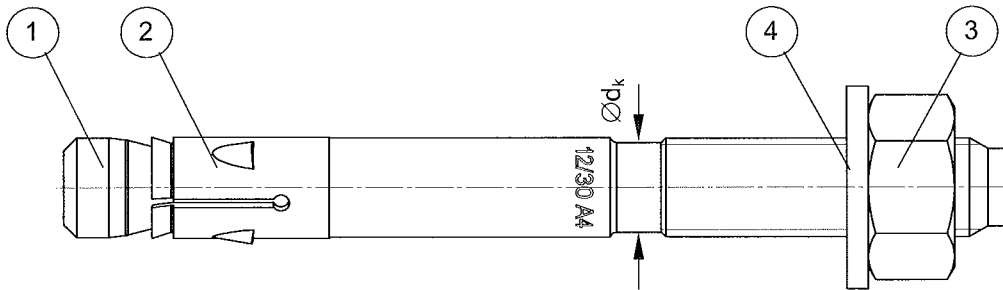

- 1) effective anchorage depth
- 2) thickness of fixture
- 3) drill hole depth
- 4) min. thickness of concrete member

- ① Cone bolt (cold – formed or metal - cut)
- ② Expansion sleeve
- ③ Hexagon nut
- ④ Washer

BTI simplex anchor BAZ, BAZ A4, BAZ C

Product and intended use

**Annex 1**

of European  
technical approval

**ETA – 09/0157**

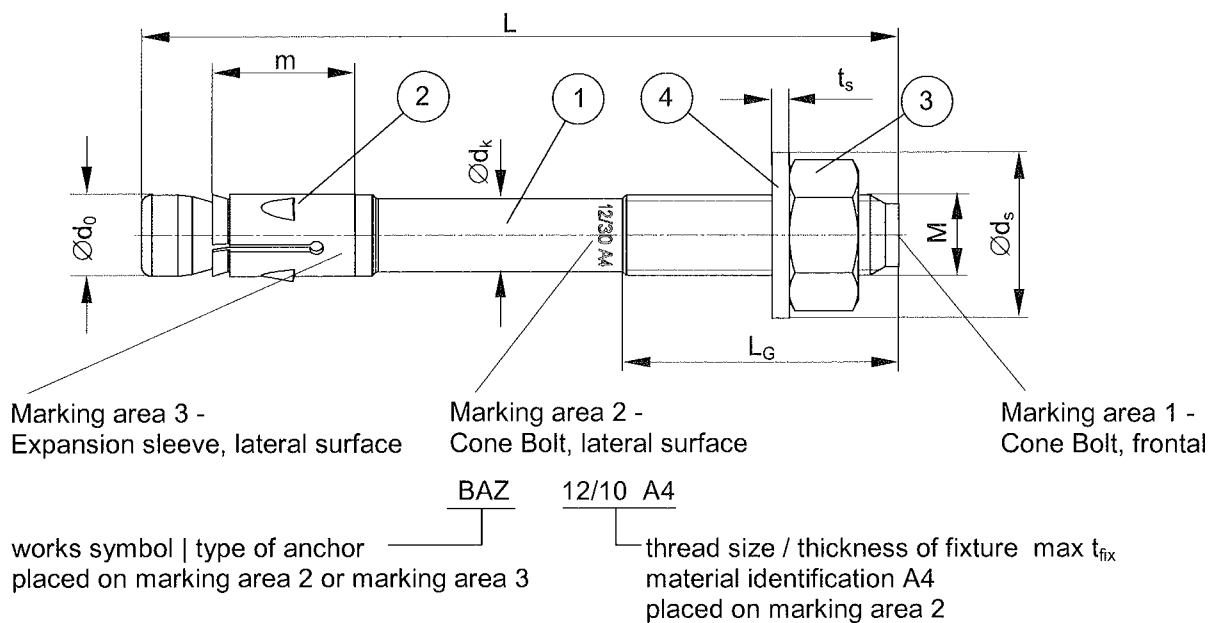

Letter-code on marking area 1 and maximum thickness of fixture  $t_{fix}$ :

marking	(A)	(B)	(C)	(D)	(E)	(F)	(G)	(H)	(I)	(K)	(L)	(M)
max $t_{fix}$ M8-M24	5	10	15	20	25	30	35	40	45	50	60	70

marking	(N)	(O)	(P)	(R)	(S)	(T)	(U)	(V)	(W)	(X)	(Y)	(Z)
max $t_{fix}$ M8-M24	80	90	100	120	140	160	180	200	250	300	350	400

**Table 1:** Anchor dimensions [mm]

Part	Designation	Deviation	BAZ, BAZ A4, BAZ C					
			M8	M10	M12	M16	M20	M24
1	Cone bolt	thread size	M8	M10	M12	M16	M20	M24
		$\varnothing d_0$	7,8	9,8	11,8	15,7	19,8	23,5
		$\varnothing d_k$	7,1	8,9	10,7	14,5	19,8	23,5
		$L_G \geq$	19	26	31	40	50	57
2	Expansion sleeve	m	17,8	20,0	20,6	27,5	33,4	40,2
		sheet thickness	1,3	1,4	1,6	2,4	2,4	3,0
3	Hexagon nut	wrench size	13	17	19	24	30	36
4	Washer	$t_s \geq$	1,4	1,8	2,3	2,7	2,7	3,7
		$\varnothing d_s \geq$	15	19	23	29	36	43
	Thickness of fixture	$t_{fix} \geq$	0	0	0	0	0	0
		$t_{fix} \leq$	200	250	300	400	500	600
	Length of anchor	$L_{min}$	67	85	100	125	140	174
		$L_{max}$	267	335	400	525	640	774

The anchor may be produced with different maximum admissible thickness of fixture.

**Table 2a: Materials BAZ**

Part	Designation	Material	Treatment
1	Cone bolt	Cold form steel or free cutting steel	Zinc plated $\geq 5 \mu\text{m}$ according to EN ISO 4042, + functional coating
2	Expansion sleeve	Cold strip, EN 10139	Zinc plated $\geq 5 \mu\text{m}$ according to EN ISO 4042
3	Hexagon nut	Steel, property class 8, EN 20 898 - 2	Zinc plated $\geq 5 \mu\text{m}$ according to EN ISO 4042, + functional coating <sup>1)</sup>
4	Washer	Cold strip, EN 10139	

<sup>1)</sup> Functional coating on hexagon nuts M8 und M10, and on washers for M12, M16 and M24

**Table 2b: Materials BAZ A4**

Part	Designation	Material	Treatment
1	Cone bolt	stainless steel EN 10 088	functional coating
2	Expansion sleeve	stainless steel EN 10 088	-
3	Hexagon nut	stainless steel EN 10 088; ISO 3506-2; property class -70	functional coating
4	Washer	stainless steel EN 10 088	-

**Table 2c: Materials BAZ C**

Part	Designation	Material	Treatment
1	Cone bolt	high corrosion resistant steel EN 10 088	functional coating
2	Expansion sleeve	high corrosion resistant steel EN 10 088	-
3	Hexagon nut	high corrosion resistant steel EN 10 088; ISO 3506-2; property class -70	functional coating
4	Washer	high corrosion resistant steel EN 10 088	-

BTI simplex anchor BAZ, BAZ A4, BAZ C

Materials

**Annex 3**of European  
technical approval**ETA – 09/0157**

**Table 3: Installation parameters**

Type of anchor / size		BAZ, BAZ A4, BAZ C					
		M8	M10	M12	M16	M20	M24
Nominal drill hole diameter	$d_0 =$ [mm]	8	10	12	16	20	24
Cutting diameter of drill bit	$d_{cut} \leq$ [mm]	8,45	10,45	12,5	16,5	20,55	24,55
Depth of drill hole in concrete	$h_1 \geq$ [mm]	55	75	90	110	125	155
Diameter of clearance hole in the fixture	$d_f \leq$ [mm]	9	12	14	18	22	26
Required torque moment	$T_{inst} =$ [Nm]	20	45	60	110	200	270

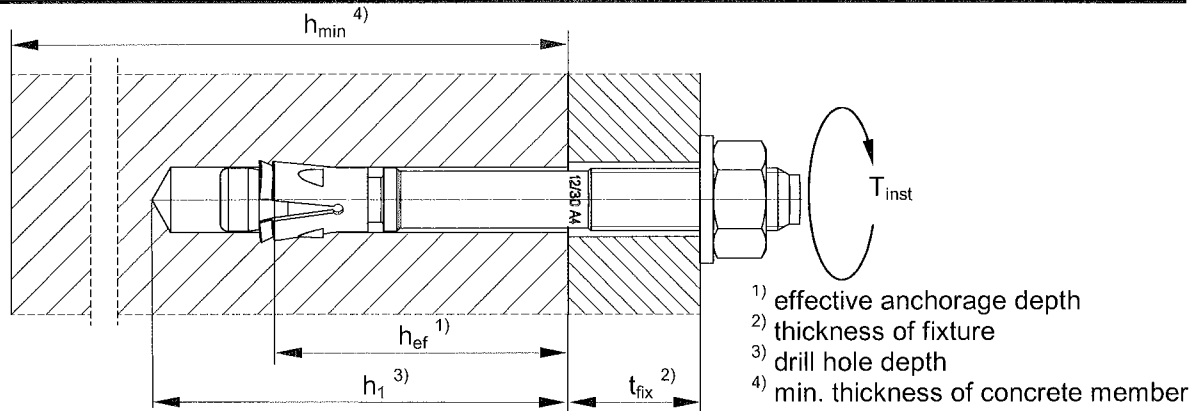

**Table 4: Minimum thickness of concrete members, minimum spacing and minimum edge distances of anchors**

Type of anchor / size		BAZ, BAZ A4, BAZ C						
		M8	M10	M12	M16	M20	M24	
Applications with concrete members of thickness $\geq 2 \times h_{ef}$	<b>Minimum thickness of concrete member</b>	$h_{min,1}$ [mm]	<b>100</b>	<b>120</b>	<b>140</b>	<b>170</b>	<b>200</b>	<b>250</b>
	<b>Non – cracked concrete</b>							
	Minimum spacing	$s_{min}$ [mm]	40	40	50	60	95	100
		for $c \geq$ [mm]	50	60	70	95	180	200
	Minimum edge distance	$c_{min}$ [mm]	40	45	55	65	95	135
		for $s \geq$ [mm]	100	80	110	150	190	235
	<b>Cracked concrete</b>							
	Minimum spacing	$s_{min}$ [mm]	35	40	45	60	95	100
for $c \geq$ [mm]		50	55	70	95	140	170	
Minimum edge distance	$c_{min}$ [mm]	40	45	55	65	85	100	
	for $s \geq$ [mm]	70	80	110	150	190	220	
Applications with concrete members of thickness $< 2 \times h_{ef}$	<b>Minimum thickness of concrete member</b>	$h_{min,2}$ [mm]	<b>80</b>	<b>100</b>	<b>120</b>	<b>140</b>	<b>160</b>	<b>200</b>
	<b>Cracked and non- cracked concrete</b>							
	Minimum spacing	$s_{min}$ [mm]	35	40	50	80	125	150
		for $c \geq$ [mm]	70	100	90	130	220	230
	Minimum edge distance	$c_{min}$ [mm]	40	60	60	65	125	135
		for $s \geq$ [mm]	100	90	120	180	230	235

Intermediate values for  $s_{min}$  and  $c_{min}$  inside of the same thickness of concrete member by linear interpolation.

BTI simplex anchor BAZ, BAZ A4, BAZ C

Parameters of installation

**Annex 4**

of European technical approval

**ETA – 09/0157**

**Table 5:** Design method A - characteristic values for tension loads

Type of anchor / size			BAZ, BAZ A4, BAZ C					
			M8	M10	M12	M16	M20	M24
<b>Steel failure</b>								
Characteristic resistance	$N_{Rk,s}$	[kN]	16,0	27,0	41,5	66,0	111,0	150,0
Partial safety factor	$\gamma_{Ms}$	<sup>1)</sup>	1,5					
<b>Pullout failure</b>								
Characteristic resistance in cracked concrete	$N_{Rk,p}$	C20/25 [kN]	5	9	16	- <sup>2)</sup>	- <sup>2)</sup>	- <sup>2)</sup>
Characteristic resistance in non - cracked concrete	$N_{Rk,p}$	C20/25 [kN]	9	16	25	- <sup>2)</sup>	- <sup>2)</sup>	- <sup>2)</sup>
Increasing factors for $N_{Rk,p}$ for cracked and non - cracked concrete	$\psi_c$	C25/30	1,10					
		C30/37	1,22					
		C35/45	1,34					
		C40/50	1,41					
		C45/55	1,48					
		C50/60	1,55					
Partial safety factor	$\gamma_{Mp}$	<sup>1)</sup>	1,5 <sup>3)</sup>					
<b>Concrete cone and splitting failure for applications with concrete members of thickness <math>\geq 2x h_{ef}</math></b>								
Effective anchorage depth	$h_{ef}$	[mm]	45	60	70	85	100	125
Min. thickness of concrete member	$h_{min,1}$	[mm]	100	120	140	170	200	250
Spacing	$s_{cr,N}$	[mm]	140	180	210	260	300	380
Edge distance	$c_{cr,N}$	[mm]	70	90	105	130	150	190
Spacing (splitting failure) <sup>4)</sup>	$s_{cr,sp}$	[mm]	140	180	210	260	370	430
Edge distance (splitting failure) <sup>4)</sup>	$c_{cr,sp}$	[mm]	70	90	105	130	185	215
Partial safety factor	$\gamma_{Mc}$	<sup>1)</sup>	1,5 <sup>3)</sup>					
<b>Concrete cone and splitting failure for applications with concrete members of thickness <math>&lt; 2x h_{ef}</math></b>								
Effective anchorage depth	$h_{ef}$	[mm]	45	60	70	85	100	125
Min. thickness of concrete member	$h_{min,2}$	[mm]	80	100	120	140	160	200
Spacing	$s_{cr,N}$	[mm]	140	180	210	260	300	380
Edge distance	$c_{cr,N}$	[mm]	70	90	105	130	150	190
Spacing (splitting failure) <sup>4)</sup>	$s_{cr,sp}$	[mm]	180	240	280	340	480	550
Edge distance (splitting failure) <sup>4)</sup>	$c_{cr,sp}$	[mm]	90	120	140	170	240	275
Partial safety factor	$\gamma_{Mc}$	<sup>1)</sup>	1,5 <sup>3)</sup>					

<sup>1)</sup> In absence of other national regulations.

<sup>2)</sup> Pullout failure not relevant.

<sup>3)</sup> The partial safety factor  $\gamma_2 = 1,0$  is included.

<sup>4)</sup> Intermediate values for  $s_{cr,sp}$  and  $c_{cr,sp}$  between concrete thickness  $h_{min,2}$  and  $h_{min,1}$  by linear interpolation.

**Table 6:** Displacements due to tension loads

Type of anchor / size			BAZ, BAZ A4, BAZ C					
			M8	M10	M12	M16	M20	M24
Tension load in cracked concrete	N	[kN]	2,3	4,2	7,5	13,2	16,4	22,9
Displacement	$\delta_{N0}$	[mm]	0,5	0,5	0,7	1,0	1,2	1,2
	$\delta_{Nzc}$	[mm]	1,2				1,4	1,5
Tension load in non - cracked concrete	N	[kN]	4,2	7,5	11,7	18,7	23,3	32,5
Displacement	$\delta_{N0}$	[mm]	0,3	0,3	0,5	0,7	1,2	1,2
	$\delta_{Nzc}$	[mm]	1,2				1,4	1,5

BTI simplex anchor BAZ, BAZ A4, BAZ C

Design method A,  
characteristic values for tension loads, displacements**Annex 5**of European  
technical approval**ETA – 09/0157**

**Table 7:** Design method A - characteristic values for shear loads

Type of anchor / size	BAZ, BAZ A4, BAZ C						
	M8	M10	M12	M16	M20	M24	
<b>Steel failure without lever arm</b>							
Characteristic resistance	$V_{Rk,s}$ [kN]	12,0	20,0	29,5	55,0	70	86
Partial safety factor	$\gamma_{Ms}^{1)}$	1,25					
<b>Steel failure with lever arm</b>							
Characteristic bending resistance	$M_{Rk,s}^0$ [Nm]	26	58	92	233	487	769
Partial safety factor	$\gamma_{Ms}^{1)}$	1,25					
<b>Concrete pryout failure</b>							
Factor in equation (5.6) of ETAG Annex C, 5.2.3.3	k	2,0	2,2	2,4	2,8	2,8	2,8
Partial safety factor	$\gamma_{Mc}^{1)}$	1,5 <sup>2)</sup>					
<b>Concrete edge failure</b>							
Effective length of anchor in shear loading	$l_f$ [mm]	45	60	70	85	100	125
Effective diameter of anchor	$d_{nom}$ [mm]	8	10	12	16	20	24
Partial safety factor	$\gamma_{Mc}^{1)}$	1,5 <sup>2)</sup>					

<sup>1)</sup> In absence of other national regulations.

<sup>2)</sup> The partial safety factor  $\gamma_2 = 1,0$  is included.

**Table 8:** Displacements due to shear loads

Type of anchor / size	BAZ, BAZ A4, BAZ C						
	M8	M10	M12	M16	M20	M24	
Shear load in cracked and non-cracked concrete	V [kN]	6,9	11,4	16,9	31,4	39,4	48,5
Displacement	$\delta_{V0}$ [mm]	2,4	4,2	4,5	3,0	3,6	3,6
	$\delta_{Vsc}$ [mm]	3,6	6,3	6,8	4,5	5,4	5,4

Installation instruction for the BTI simplex anchor

BAZ, BAZ A4 and BAZ C M8 to M24

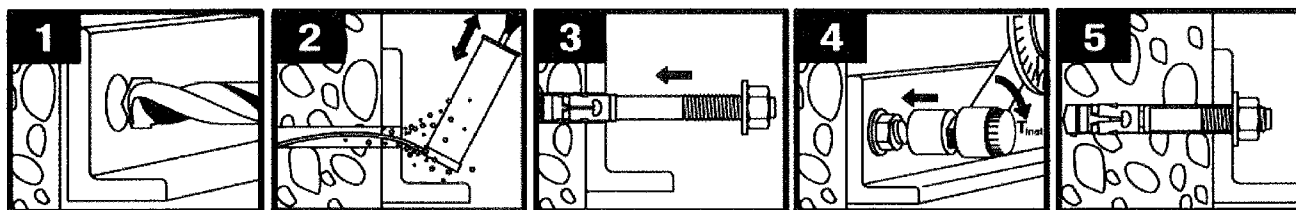

BTI simplex anchor BAZ, BAZ A4, BAZ C

Design method A,  
characteristic values for shear loads, displacements  
Installation instruction

**Annex 6**

of European  
technical approval

**ETA – 09/0157**

**Table 9:** Characteristic values to tension loads under fire exposure in cracked and non-cracked concrete C20/25 to C50/60

Type of anchor/size		BAZ, BAZ A4, BAZ C																							
		M8			M10			M12			M16			M20			M24								
Fire resistance duration	R... [min]	30	60	90	120	30	60	90	120	30	60	90	120	30	60	90	120	30	60	90	120				
		<b>Steel failure:</b>																							
Characteristic resistance	$N_{Rk,s,fi}$ [kN]	1,4	1,2	0,9	0,8	2,8	2,3	1,9	1,6	5,0	4,1	3,2	2,8	9,4	7,7	6,0	5,2	14	12	9	8	21	17	13	11
<b>Pullout failure:</b>																									
Characteristic resistance in concrete C20/25 to C50/60	$N_{Rk,c,fi}$ [kN]	1,3	1,0	1,8	2,3	4,0	3,2	- <sup>1)</sup>	- <sup>1)</sup>	- <sup>1)</sup>	- <sup>1)</sup>	- <sup>1)</sup>	- <sup>1)</sup>	- <sup>1)</sup>	- <sup>1)</sup>	- <sup>1)</sup>	- <sup>1)</sup>	- <sup>1)</sup>	- <sup>1)</sup>	- <sup>1)</sup>	- <sup>1)</sup>	- <sup>1)</sup>	- <sup>1)</sup>	- <sup>1)</sup>	- <sup>1)</sup>
<b>Concrete cone failure:</b>																									
Characteristic resistance in concrete C20/25 to C50/60	$N_{Rk,c,fi}$ [kN]	2,4	1,9	5,0	4,0	7,3	5,9	12,0	9,6	18	14	31	25												
Spacing	$S_{cr,N}$	4 x $h_{ef}$																							
	$S_{min}$ [mm]	35	40			45	60			95	100														
Edge Distance	$C_{cr,N}$	2 x $h_{ef}$																							
	$C_{min}$ [mm]	$C_{min} = 2 \times h_{ef}$ If fire attack is from more than one side, the edge distance of the anchor has to be bigger than 300 mm.																							

In absence of other national regulations the partial safety factor for resistance under fire exposure  $\gamma_{M,fi} = 1,0$  is recommended.  
 1) Pullout failure is not decisive

Doc: ETA-BAZ-E

BTI simplex anchor BAZ, BAZ A4, BAZ C  
 Characteristic values of tension load resistance under fire exposure

**Annex 7**  
 of European technical approval  
**ETA – 09/0157**

**Table 10:** Characteristic values to shear loads under fire exposure in cracked and non-cracked concrete C20/25 to C50/60

Type of anchor/size	BAZ, BAZ A4, BAZ C															
	M8		M10		M12		M16		M20		M24					
Fire resistance duration [min]	30	60	90	120	30	60	90	120	30	60	90	120	30	60	90	120
	1,8	1,6	1,3	1,2	3,6	2,9	2,2	1,9	6,3	4,9	3,5	2,8	11,7	9,1	6,6	5,3
Characteristic resistance $V_{Rk,s,fi}$ [kN]	1,4	1,2	1,0	0,8	3,6	3,0	2,4	2,1	7,8	6,4	5,0	4,3	19,9	16,3	12,7	10,9
Characteristic resistance $M^0_{Rk,s,fi}$ [Nm]	1,4	1,2	1,0	0,8	3,6	3,0	2,4	2,1	7,8	6,4	5,0	4,3	19,9	16,3	12,7	10,9
<b>Steel failure without lever arm:</b>																
<b>Steel failure with lever arm:</b>																
<b>Concrete pryout failure:</b>																

In Equation (5.6) of ETAG 001, Annex C, 5.2.2.3 the k-factor of Table 7 and the relevant values of  $N^0_{Rk,c,fi}$  of Table 9 have to be considered.

**Concrete edge failure:**

The initial value  $V^0_{Rk,c,fi}$  of the characteristic resistance in concrete C20/25 to C50/60 under fire exposure may be determined by:

$$V^0_{Rk,c,fi} = 0,25 \times V^0_{Rk,c} \quad (R30, R 60, R90) \quad V^0_{Rk,c,fi} = 0,20 \times V^0_{Rk,c} \quad (R120)$$

with  $V^0_{Rk,c}$  initial value of the characteristic resistance in cracked concrete C20/25 under normal temperature.

In absence of other national regulations the partial safety factor for resistance under fire exposure  $\gamma_{M,fi} = 1.0$  is recommended.

Doc: ETA-BAZ-E

BTI simplex anchor BAZ, BAZ A4, BAZ C  
 Characteristic resistance under shear loading with fire exposure

**Annex 8**  
 of European technical approval

**ETA – 09/0157**