

European Technical Approval ETA-06/0028

English translation prepared by DIBt - Original version in German language

| | |
|---|---|
| Handelsbezeichnung <i>Trade name</i> | Lobatherm System P leicht |
| Zulassungsinhaber <i>Holder of approval</i> | quick-mix Gruppe GmbH & Co. KG Mühlenschweg 6 49090 Osnabrück DEUTSCHLAND |
| Zulassungsgegenstand und Verwendungszweck <i>Generic type and use of construction product</i> | Außenseitiges Wärmedämm-Verbundsystem mit Putzschicht zur Wärmedämmung von Gebäuden <i>External Thermal Insulation Composite System with rendering for the use as external insulation of building walls</i> |
| Geltungsdauer: <i>Validity:</i> | 8 February 2006 |
| | 8 February 2011 |
| verlängert <i>extended</i> | 9 February 2011 |
| | 8 February 2016 |
| Herstellwerk <i>Manufacturing plant</i> | quick-mix Gruppe GmbH & Co. KG Mühlenschweg 6 49090 Osnabrück DEUTSCHLAND |

Diese Zulassung umfasst
This Approval contains

18 Seiten einschließlich 1 Anhang
18 pages including 1 annex

I LEGAL BASES AND GENERAL CONDITIONS

- 1 This European technical approval is issued by Deutsches Institut für Bautechnik in accordance with:
 - Council Directive 89/106/EEC of 21 December 1988 on the approximation of laws, regulations and administrative provisions of Member States relating to construction products¹, modified by Council Directive 93/68/EEC² and Regulation (EC) N° 1882/2003 of the European Parliament and of the Council³;
 - Gesetz über das In-Verkehr-Bringen von und den freien Warenverkehr mit Bauprodukten zur Umsetzung der Richtlinie 89/106/EWG des Rates vom 21. Dezember 1988 zur Angleichung der Rechts- und Verwaltungsvorschriften der Mitgliedstaaten über Bauprodukte und anderer Rechtsakte der Europäischen Gemeinschaften (Bauproduktengesetz - BauPG) vom 28. April 1998⁴, as amended by law of 31 October 2006⁵;
 - Common Procedural Rules for Requesting, Preparing and the Granting of European technical approvals set out in the Annex to Commission Decision 94/23/EC⁶;
 - Guideline for European technical approval of "External Thermal Insulation Composite Systems with Rendering", ETAG 004.
- 2 Deutsches Institut für Bautechnik is authorized to check whether the provisions of this European technical approval are met. Checking may take place in the manufacturing plant. Nevertheless, the responsibility for the conformity of the products to the European technical approval and for their fitness for the intended use remains with the holder of the European technical approval.
- 3 This European technical approval is not to be transferred to manufacturers or agents of manufacturers other than those indicated on page 1, or manufacturing plants other than those indicated on page 1 of this European technical approval.
- 4 This European technical approval may be withdrawn by Deutsches Institut für Bautechnik, in particular pursuant to information by the Commission according to Article 5(1) of Council Directive 89/106/EEC.
- 5 Reproduction of this European technical approval including transmission by electronic means shall be in full. However, partial reproduction can be made with the written consent of Deutsches Institut für Bautechnik. In this case partial reproduction has to be designated as such. Texts and drawings of advertising brochures shall not contradict or misuse the European technical approval.
- 6 The European technical approval is issued by the approval body in its official language. This version corresponds fully to the version circulated within EOTA. Translations into other languages have to be designated as such.

¹ Official Journal of the European Communities L 40, 11 February 1989, p. 12

² Official Journal of the European Communities L 220, 30 August 1993, p. 1

³ Official Journal of the European Union L 284, 31 October 2003, p. 25

⁴ *Bundesgesetzblatt Teil I 1998*, p. 812

⁵ *Bundesgesetzblatt Teil I 2006*, p. 2407, 2416

⁶ Official Journal of the European Communities L 17, 20 January 1994, p. 34

II SPECIFIC CONDITIONS OF THE EUROPEAN TECHNICAL APPROVAL

1 Definition of products and intended use

The External Thermal Insulation Composite System "Lobatherm System P leicht" called ETICS in the following text, is designed and installed in accordance with the ETA-holder's design and installation instructions, deposited with the Deutsches Institut für Bautechnik (DIBt). The ETICS comprises the following components, which are factory-produced by the ETA-holder or a supplier. It's made up on site from these. The ETA-holder is ultimately responsible for the ETICS.

1.1 Definition of the construction product

| | Components (see clause 2.3 for further description, characteristics and performances) | Coverage [kg/m ²] | Thickness [mm] |
|--|---|---|---|
| Insulation material with associated method of fixing | Bonded ETICS: <ul style="list-style-type: none"> • Insulation product factory-prefabricated expanded polystyrene (EPS) to EN 13163:2008 <ul style="list-style-type: none"> - standard EPS - elastified EPS • Adhesives (minimum bonded surface 40 %) cement based powder requiring addition of about 22-33% of water) <ul style="list-style-type: none"> - AKM-SP Armierungs- und Klebemörtel Super-Plus - SKS-L Spachtel- und Klebemörtel leicht - AKM Armierungs- und Klebemörtel - SKS Spachtel- und Klebemörtel | <p style="text-align: center;">-</p> <p style="text-align: center;">-</p> <p style="text-align: center;">ca. 4 (prepared)</p> <p style="text-align: center;">ca. 5 (prepared)</p> | <p style="text-align: center;">≤ 300</p> <p style="text-align: center;">≤ 200</p> <p style="text-align: center;">-</p> <p style="text-align: center;">-</p> |
| | Mechanically fixed ETICS with profiles and supplementary adhesive: <ul style="list-style-type: none"> • Insulation product factory-prefabricated expanded polystyrene (EPS) to EN 13163:2008 <ul style="list-style-type: none"> - standard EPS • Supplementary adhesive (equal to bonded ETICS, minimum bonded surface 20 %) • Profiles <ul style="list-style-type: none"> - PVC-Halteleiste - PVC-Verbindungsleiste Polyvinyl chloride (PVC) profiles | - | 60 to 200 |

| | Components (see clause 2.3 for further description, characteristics and performances) | Coverage [kg/m ²] | Thickness [mm] |
|---|---|--------------------------------------|-----------------------------------|
| Insulation material with associated method of fixing | <ul style="list-style-type: none"> • Anchors for profiles <ul style="list-style-type: none"> - ejothem SK U - WS 8 L - WS 8 N - ejothem SDK U - IsoFux ND-8Z - SDF-K plus, SDF-K plus U, SDF-K plus UB - ejothem NK U | | |
| | <p>Mechanically fixed ETICS with anchors and supplementary adhesive:</p> <ul style="list-style-type: none"> • Insulation product factory-prefabricated expanded polystyrene (EPS) to EN 13163:2008 <ul style="list-style-type: none"> - standard EPS - elastified EPS • Supplementary adhesive (equal to bonded ETICS, minimum bonded surface 40 %) • Anchors for insulation product <ul style="list-style-type: none"> - ejothem ST U - KEW TSD 8 - TERMOZ 8 SV - KOELNER KI8M - ejothem NTK U <p>and anchors with ETA according to ETAG 014⁷ with characteristics defined in clause 2.3.2</p> | <p>–</p> <p>–</p> | <p>60 to 300</p> <p>60 to 200</p> |
| Base coat | <p>AKM-SP Armierungs- und Klebemörtel Super-Plus SKS-L Spachtel- und Klebemörtel leicht Identical with the equally named adhesive(s) given above.</p> | <p>4 to 5 (prepared)</p> | <p>4 to 5</p> |
| Glass fibre mesh | <p>Standard mesh Alkali- and slide-resistant glass fibre mesh with mass per unit area of about 165 g/m².</p> | <p>–</p> | <p>–</p> |
| | <p>Reinforced mesh: GWS Armierungsgewebe mesh size of about 4.0 mm x 4.0 mm.</p> | <p>–</p> | <p>–</p> |
| | <p>Reinforced mesh: GWS Armierungsgewebe mesh size of about 7.0 mm x 8.0 mm.</p> <p>Panzergewebe PGP (implemented in addition to the standard mesh to improve the impact resistance) Alkali- and slide-resistant glass fibre mesh with mass per unit area of about 480 g/m.</p> | <p>–</p> | <p>–</p> |

| | Components (see clause 2.3 for further description, characteristics and performances) | Coverage [kg/m ²] | Thickness [mm] | |
|-----------------------|---|---|---------------------------------------|----------|
| Finishing coat | <ul style="list-style-type: none"> Thin layered cement based powder requiring addition of about 22 to 33 % of water: EFS Edelfeinputz | About 7 | About 5 | |
| | <ul style="list-style-type: none"> SPS Scheibenputz (particle size 2 - 3 and 5 mm) SPP Scheibenputz PAROS (particle size 1 - 2 und 3 mm mm) MRS Münchner Rauputz (particle size 3 mm) VPS Varioputz | 3 to 7 3 to 5 About 4.5 About 5 | Regulated by particle size About 8 | |
| | <ul style="list-style-type: none"> Thick layered cement based powder requiring addition of about 22 to 33 % of water: KPS Kratzputz (particle size 1 – 2 – 3 – 4 und 5 mm) | About 20 | | About 12 |
| | <ul style="list-style-type: none"> Thin layered cement based powder requiring addition of about 30 to 38 % of water: LSS Leicht-Scheibenputz (particle size 2 - 3 und 4 mm) LRS Leicht-Rillenputz (particle size - 3 und 4 mm) | 2 to 5 2 to 5 | Regulated by particle size | |
| | Ancillary material | Description in accordance with clause 3.2.2.5 of ETAG 004 and decorative coatings compatible with the ETICS to be applied to the finishing coat. Remains the responsibility of the ETA-holder. | | |

1.2 Intended use

This ETICS is intended to be used as external insulation to the walls of buildings made of masonry (bricks, blocks, stones ...) or concrete (cast on site or as prefabricated panels) with and without rendering (Class A1 or A2 - s1,d0 according to EN 13501-1:2007). It shall be designed to give the wall to which it is applied satisfactory thermal insulation.

The ETICS is non load-bearing construction element. It does not contribute directly to the stability of the wall on which it is installed, but it can contribute to durability by providing enhanced protection from the effects of weathering.

The ETICS can be used on new or existing (retrofit) vertical walls.

The ETICS is not intended to ensure the air tightness of the building structure.

The choice of the method of fixing depends on the characteristics of the substrate, which could need preparation (see clause 7.2.1 of ETAG 004) and on the national instructions.

The provisions made in this European technical approval (ETA) based upon the assumed intended working life of the ETICS of at least 25 years, provided that the conditions laid down in clauses 4.2, 5.1 and 5.2 for the packaging, transport, storage, installation as well as appropriate use, maintenance and repair are met. The indications given on the working life cannot be interpreted as a guarantee given by the manufacturer or the Approval Body, but should only be regarded as a means to choosing the appropriate products in relation to the expected, economically reasonable working life of the works.

2 Characteristics of products and methods of verification

2.1 General

The assessment of the fitness for use of the ETICS for the intended use according to the Essential Requirements was carried out in compliance with ETAG 004, "Guideline for European Technical Approval of External Thermal Insulation Composite Systems with rendering", edition March 2000 (called ETAG 004 in this ETA).

Characteristics (of the components as well as of the ETICS), not mentioned in this ETA nor in the annexe/s shall correspond to the respective values laid down in the technical documentation of this ETA.

2.2 Characteristics of the ETICS

2.2.1 Reaction to fire

Class according to EN 13501-1:2007: F without testing (no performance determined).

2.2.2 Water absorption (capillarity test)

Base coat:

| Base coat | Water absorption after 1 h < 1 kg/m ² | Water absorption after 24 h < 0.5 kg/m ² |
|--|---|--|
| AKM-SP Armierungs- und Klebemörtel Super-Plus | x | x |
| SKS-L Spachtel- und Klebemörtel leicht | x | x |

| Rendering system: Base coat with finishing coat <i>and</i> <i>compatible key coat</i> indicated hereafter | Water absorption after 24 h | |
|---|-----------------------------|-------------------------|
| | < 0.5 kg/m ² | ≥ 0.5 kg/m ² |
| EFS Edelfeinputz | x | |
| SPS Scheibenputz | x | |
| SPP Scheibenputz PAROS | x | |
| MRS Münchner Rauputz | x | |
| VPS Varioputz | x | |
| KPS Kratzputz | x | |
| LSS Leicht-Scheibenputz | x | |

2.2.3 Hygrothermal behaviour

Hygrothermal cycles have been performed on a rig. None of the following defects occur during the testing:

- blistering or peeling of any finishing
- failure or cracking associated with joints between insulation product boards or profiles fitted with the system
- detachment of render
- cracking allowing water penetration to the insulation layer

The ETICS is so assessed resistant to hygrothermal cycles.

English translation prepared by DIBt

2.2.4 Freeze/thaw behaviour

The water absorption of the base coat as well as the rendering system is less than 0.5 kg/m² after 24 hours for all configurations of the ETICS. The ETICS is so assessed as freeze/thaw resistant.

2.2.5 Impact resistance

The verified resistance to hard body impact of the ETICS with both base coats reinforced with "GWS Armierungsgewebe" and all finishing coats results in category II. The resistance to perforation has not to be verified, because of a total render thickness of not less than 6 mm.

The impact resistance of all other configurations of the ETICS with the meshes "GWP Armierungsgewebe" and "Panzerewebe PGP" is not determined (npd).

2.2.6 Water vapour permeability

| Rendering system: Base coat with finishing coat (evaluated without decorative) | Equivalent air thickness s_d |
|--|---|
| EFS Edelfeinputz | ≤ 1.0 m (Test result obtained with the layer thickness 5 mm: 0.3 m) |
| SPS Scheibenputz | ≤ 1.0 m (Test result obtained with particle size 3 mm: 0.3 m) |
| SPP Scheibenputz PAROS | ≤ 1.0 m (Test result obtained with particle size 3 mm: 0.3 m) |
| MRS Münchner Rauputz | ≤ 1.0 m (Test result obtained with particle size 3 mm: 0.3 m) |
| VPS Varioputz | ≤ 1.0 m (Test result obtained with the layer thickness 8 mm: 0.3 m) |
| KPS Kratzputz | ≤ 1.0 m (Test result obtained with the layer thickness 12 mm: 0.4 m) |
| LSS Leicht-Scheibenputz | ≤ 1.0 m (Test result obtained with particle size 3 mm: 0.2 m) |

2.2.7 Emission of dangerous substances or radiation

The ETICS complies with the provisions of Guidance Paper H ("A harmonized approach related to dangerous substances under the construction product directives Revision August 2002").

In addition to the specific clauses relating to dangerous substances contained in this ETA, there may be other requirements applicable to the products falling within its scope (e.g. transposed European legislation and national laws, regulations and administrative provisions). In order to meet the provisions of the Construction Products Directive, these requirements need also to be complied with, when and where they apply.

English translation prepared by DIBt

2.2.8 Safety in use

2.2.8.1 Bond strengths

Bond strength between base coat and insulation product (EPS)

| Base coat | Conditioning | | |
|---|---------------|--------------------------------------|--|
| | Initial state | After hygrothermal cycles on the rig | After freeze/thaw test |
| AKM-SP Armierungs- und Klebemörtel Super-Plus | ≥ 0.08 MPa | ≥ 0.08 MPa | Test not required because freeze/thaw cycles not necessary |
| SKS-L Spachtel- und Klebemörtel leicht | ≥ 0.08 MPa | ≥ 0.08 MPa | |

Bond strength between adhesive and substrate resp. insulation product (EPS)

| Adhesive | Substrate resp. insulation product | Conditioning | | |
|---|------------------------------------|---------------|-------------------------------------|-------------------------------------|
| | | Initial state | 2 d immersion in water + 2 h drying | 2 d immersion in water + 7 d drying |
| AKM-SP Armierungs- und Klebemörtel Super-Plus | Concrete | ≥ 0.25 MPa | ≥ 0.08 MPa | ≥ 0.25 MPa |
| | EPS | ≥ 0.08 MPa | ≥ 0.03 MPa | ≥ 0.08 MPa |
| SKS-L Spachtel- und Klebemörtel leicht | Concrete | ≥ 0.25 MPa | ≥ 0.08 MPa | ≥ 0.25 MPa |
| | EPS | ≥ 0.08 MPa | ≥ 0.03 MPa | ≥ 0.08 MPa |
| AKM Armierungs- und Klebemörtel | Concrete | ≥ 0.25 MPa | ≥ 0.08 MPa | ≥ 0.25 MPa |
| | EPS | ≥ 0.08 MPa | ≥ 0.03 MPa | ≥ 0.08 MPa |
| SKS Spachtel- und Klebemörtel | Concrete | ≥ 0.25 MPa | ≥ 0.08 MPa | ≥ 0.25 MPa |
| | EPS | ≥ 0.08 MPa | ≥ 0.03 MPa | ≥ 0.08 MPa |

Bonded surface:

For bonded ETICS the calculated minimal bonded surface area, according to ETAG 004, clause 6.1.4.1.3 is 40 %

2.2.8.2 Fixing strength (displacement test)

Test not required because the ETICS fulfils the following criteria to clause 5.1.4.2 of ETAG 004:

- the bonded area exceeds 20 %
- $E \cdot d < 50\,000 \text{ N/mm}$
(E: modulus of elasticity of the base coat – d: mean dried thickness of the base coat)

English translation prepared by DIBt

2.2.8.3 Wind load resistance

Safety in use of mechanically fixed ETICS using profiles

The following failure loads only apply to the listed combination (EPS panel's characteristics) / (way of fixing the profiles) and the characteristics of the insulation product given in clause 2.3.1.

| | | |
|--|--|-------------------------------|
| Characteristics of the EPS (standard EPS) | Dimensions | 500 mm x 500 mm |
| | Thickness | ≥ 60 mm |
| | Tensile strength perpendicular to the faces | ≥ 150 kPa |
| | Shear modulus | ≥ 1.0 N/mm ² |
| Failure loads [N / panel] (Static Foam Block Test) | Horizontal profiles fixed every 30 cm and 49.4 cm long vertical connection profiles | Minimal: 950 Average: 1010 |

Safety in use of mechanically fixed ETICS using anchors

The following failure loads only apply to the listed combination (EPS panel's characteristics) / (anchor plate's characteristics) and the characteristics of the insulation product given in clause 2.3.1.

| | | | | |
|---|--|--------------------|-------------------------------|------------------------------|
| Apply to all anchors listed in the Table in clause 1.1 mounted on the insulation panels surface | | | | |
| Characteristics of the EPS (standard EPS) | Thickness | | ≥ 60 mm | |
| | Tensile strength perpendicular to the faces | | ≥ 100 kPa | |
| | Shear modulus | | ≥ 1.0 N/mm ² | |
| Plate diameter of anchor | | | Ø 60 mm | Ø 90 mm |
| Failure loads [N] | Anchors not placed at the panel joints (Static Foam Block Test) | R _{panel} | Minimal: 510 Average: 520 | Minimal: 720 Average: 730 |
| | Anchors placed at the panel joints (Pull-through test) | R _{joint} | Minimal : 400 Average: 430 | Minimal: 430 Average: 470 |

| | | | | |
|---|--|--------------------|------------------------------|--|
| Apply to all anchors listed in the Table in clause 1.1 mounted on the insulation panels surface | | | | |
| Characteristics of the EPS (elastified EPS) | Thickness | | ≥ 60 mm | |
| | Tensile strength perpendicular to the faces | | ≥ 80 kPa | |
| | Shear modulus | | ≥ 0.3 N/mm ² | |
| Plate diameter of anchor | | | Ø 60 mm | |
| Failure loads [N] | Anchors not placed at the panel joints (Static Foam Block Test) | R _{panel} | Minimal: 350 Average: 360 | |
| | Anchors placed at the panel joints (Pull-through test) | R _{joint} | Minimal: 300 Average: 310 | |

The failure loads specified above only apply to the following anchors with deep mounting under the given conditions of installation:

| Anchor | Thickness of the EPS [d] | Conditions of installation * |
|--|---|---|
| ejotherm STR U (ETA-04/0023) | 100 mm > d ≥ 80 mm (for standard and elastified EPS) | – Maximum installation depth of the anchor plate: 15 mm (thickness of insulation cover) – Maximum depth of die: 5 mm |
| | ≥ 100 mm (for standard and elastified EPS) | – Maximum installation depth of the anchor plate: 15 mm (thickness of insulation cover) – Maximum depth of die: 20 mm |
| IsoFux NDT8LZ (ETA-05/0080) | ≥ 80 mm (for standard and elastified EPS) | – Maximum depth of countersink: 20 mm |
| TERMOZ 8 SV (ETA-06/0180) | ≥ 80 mm (for standard EPS only) | – Maximum installation depth of the anchor plate: 15 mm (thickness of insulation cover) |
| * According to the appropriate ETA of anchor | | |

The wind load resistance R_d of the ETICS is calculated as follows:

$$R_d = \frac{R_{\text{panel}} \cdot n_{\text{panel}} + R_{\text{joint}} \cdot n_{\text{joint}}}{\gamma}$$

n_{panel} : number (per m²) of anchors not placed at the panel joints

n_{joint} : number (per m²) of anchors placed at the panel joint

γ : national safety factor

2.2.9 Thermal resistance

The nominal value of the additional thermal resistance R provided by the ETICS to the substrate wall is calculated in accordance with EN ISO 6946:2007 from the nominal value of the insulation product's thermal resistance R_D given accompanied to the CE marking and from the thermal resistance of the rendering system R_{render} which is about 0.02 (m² · K)/W.

$$R = R_D + R_{\text{render}}$$

The thermal bridges caused by anchors increase the thermal transmittance U . This influence had to take into account according to EN ISO 6946:2007.

$$U_c = U + \chi_p \cdot n$$

where: $\chi_p \cdot n$

n

χ_p

$\chi_p = 0.004$ W/K

$\chi_p = 0.002$ W/K

Corrected thermal transmittance

influence of thermal bridges

number of anchors per m²

local influence of thermal bridge caused by an anchor. The values listed below can be taken into account, if not specified in the anchor's technical approval

for anchors with a galvanized steel screw with the head covered by a plastic material

for anchors with a stainless steel screw with the head covered by plastic material, and for anchors with an air gap at the head of the screw

The thermal bridges caused by profiles are negligible.

English translation prepared by DIBt

2.2.10 Aspects of durability and serviceability

In addition to the hygrothermal cycle test on the rig (see clause 2.2.3) an extensive experience on site has been assessed by the DIBt in Germany.

The rendering system (base coat with each finishing coat indicated in the Table in clause 1.1) has proofed its bond strength after ageing by experience on site.

2.3 Characteristics of the components

Detailed information on the chemical composition and other identifying characteristics of the components, following Annex C of ETAG 004 have been deposited with the DIBt.

Further information can be observed from the product data sheets, which are part of the technical documentation for this ETA.

2.3.1 Thermal insulation product

Factory-prefabricated, uncoated panels made of expanded polystyrene (EPS) to EN 13163:2008 shall be used, having the description and characteristics defined in the Table below.

| Description and characteristics | For bonded ETICS | For mechanically fixed ETICS | |
|--|---|---|--|
| | | with anchors and supplementary adhesive | with profiles and supplementary adhesive |
| Reaction to fire; EN 13501-1:2007 | No performance determined (Class F) | | |
| Thermal resistance [(m ² ·K)/W] | Defined in the CE marking in reference to EN 13163:2008 | | |
| Tolerances | | | |
| Length; EN 822:1994 | ± 0.6 % or ± 3 mm whichever gives the greatest numerical tolerance (class L1 or class L2) | | |
| Width [mm]; EN 822:1994 | ± 2 (class W2) | | |
| Thickness [mm]; EN 823:1994 | ± 1 (class T2) | | |
| Squareness [mm/m]; EN 824:1994 | ± 2 (class S2) | | |
| Flatness [mm/m]; EN 825:1994 | 5 (class P4) | | |
| Dimensional stability under | | | |
| - laboratory conditions [%]; EN 1603:1996 | ± 0.2 (class DS(N)2) | | |
| - specified temperature and humidity conditions [%]; EN 1604:1996 | 2 (level DS(70,-)2 or level DS(70,-)1) | | |
| Water absorption (long term partial immersion) [kg/m ²]; EN 12087:1997 | W _{lp} ≤ 0.5 | | |
| Water vapour diffusion resistance factor; EN 12086:1997 | μ = 20 – 70 | | |

| Description and characteristics | For bonded ETICS | For mechanically fixed ETICS | |
|---|--------------------------------------|---|--|
| | | with anchors and supplementary adhesive | with profiles and supplementary adhesive |
| Tensile strength perpendicular to the faces in dry conditions * [kPa]; EN 1607:1996 | | | |
| - standard EPS | $\sigma_{mt} \geq 80$ | $\sigma_{mt} \geq 100$ | $\sigma_{mt} \geq 150$ |
| - elastified EPS ** | $\sigma_{mt} \geq 80$ | $\sigma_{mt} \geq 80$ | Not used |
| Bending strength ** [kPa]; EN 12089:1997 | $\sigma_b \geq 50$ | | |
| Apparent density [kg/m ³]; EN 1602:1996 | $\rho_a \leq 30$ $\rho_a \leq 20$ | | |
| Shear strength * [kPa]; EN 12090:1997 | $20 \leq f_{tk} \leq 100$ | | |
| Shear modulus [MPa]; EN 12090:1997 | $1.0 \leq G_m \leq 3.0$ | | |
| - standard EPS | | | |
| - elastified EPS *** | $0.3 \leq G_m \leq 1.0$ | $0.3 \leq G_m \leq 1.0$ | Not used |
| Testing of characteristics see EN 13163:2008. | | | |
| * Minimal value of all single values. | | | |
| ** Elastified EPS is made from standard EPS by short time high load pressing to reduce the dynamic stiffness. The protection against noise of the entire wall is improved by the use of elastified EPS related to an ETICS with standard EPS. | | | |

Thermal insulation materials for mechanically fixed ETICS with profiles must circumferentially at the edges, 24 mm from the inner surface, get an approx. 3 mm wide and 13 to 18 mm deep groove cut-in at the factory.

2.3.2 Anchors

The anchors listed in the Table in clause 1.1 with reference to the respective ETA are to be used in the mechanically fixed ETICS.

| Trade name | ETA-number |
|---|-------------|
| ejothem ST U, ejothem SK U | ETA-02/0018 |
| WS 8 L | ETA-02/0019 |
| WS 8 N | ETA-03/0019 |
| ejothem SDK U | ETA-04/0023 |
| KEW TSD 8 | ETA-04/0030 |
| IsoFux ND-8Z | ETA-04/0032 |
| SDM-T plus, SDF-K plus U, SDF-K plus UB | ETA-04/0064 |
| ejothem NK U | ETA-05/0009 |
| TERMOZ 8 SV | ETA-06/0180 |
| KOELNER KI8M | ETA-06/0191 |
| ejothem NTK U | ETA-07/0026 |

English translation prepared by DIBt

Additionally all anchors with ETA according to ETAG 014⁷ with characteristics having the description below shall be used:

- plate diameter of anchor ≥ 60 mm resp. ≥ 90 mm
- plate stiffness ≥ 0.3 kN/mm
- load resistance of the anchor plate ≥ 1.0 kN

These characteristics and the characteristic tension resistance of the anchors shall be taken from the corresponding ETA.

2.3.3 Profiles

Polyvinyl chloride (PVC) profiles, PVC-U, EGL, 082-05-T33 to EN ISO 1163-1:1999, with the measurements according to Annex 1 are to be used in the mechanically fixed ETICS with profiles.

The Pull-through resistance of fixings from profiles is ≥ 500 N.

2.3.4 Render (base coat)

The average value of crack width of the base coat reinforced with the glass fibre mesh measured at a render strain value of 1 % is:

| Base coat | Glass fibre mesh | Average value of crack width $w_{m(1\%)}$ |
|---|----------------------|---|
| AKM-SP Armierungs- und Klebemörtel Super-Plus | GWS Armierungsgewebe | 0.12 mm |
| | GWP Armierungsgewebe | No performance determined |
| SKS-L Spachtel- und Klebemörtel leicht | GWS Armierungsgewebe | 0.12 mm |
| | GWP Armierungsgewebe | No performance determined |

2.3.5 Reinforcement (glass fibre mesh)

Characteristics (alkali resistance): Pass

| | GWS Armierungsgewebe | | GWP Armierungsgewebe | |
|--|----------------------|-----------|----------------------|-----------|
| | Warp | Weft | Warp | Weft |
| Residual strength after ageing [N/mm] | ≥ 20 | ≥ 20 | ≥ 20 | ≥ 25 |
| Relative residual resistance after ageing in % of the strength in the as-delivered state | ≥ 50 | ≥ 50 | ≥ 55 | ≥ 50 |

3 Evaluation and attestation of conformity and CE-marking

3.1 System of attestation of conformity

According to the decision 97/556/EC of the European Commission⁸ amended by 2001/596/EC⁹ system 1 or 2+ of the attestation of conformity applies depending on reaction to fire.

Considering Class F for reaction to fire of the ETICS, the system of attestation of conformity is system 2+ .

This system of attestation of conformity is defined as follows:

⁸ Official Journal of the European Communities/Union L229/14 of 20.08.1997
⁹ Official Journal of the European Communities/Union L 209/33 of 02.08.2001

System 2+: Declaration of conformity of the product by the manufacturer on the basis of:

- (a) Tasks for the manufacturer:
 - (1) initial type-testing of the product;
 - (2) factory production control;
 - (3) testing of samples taken at the factory in accordance with a prescribed test plan.
- (b) Tasks for the notified body:
 - (4) certification of factory production control on the basis of:
 - initial inspection of factory and of factory production control;
 - continuous surveillance, assessment and approval of factory production control.

3.2 Responsibilities

3.2.1 Tasks for the manufacturer

3.2.1.1 Factory production control

The manufacturer shall exercise permanent internal control of production. All the elements, requirements and provisions adopted by the manufacturer shall be documented in a systematic manner in the form of written policies and procedures, including records of results performed. This production control system shall insure that the ETICS and the components are in conformity with this ETA.

The manufacturer shall only use raw materials stated in the technical documentation of this ETA. The incoming raw materials are subjected to verifications by the manufacturer before acceptance.

The factory production control shall be in accordance with the "Control plan"¹⁰ which is part of the technical documentation of this ETA. The "Control plan"¹⁰ has been agreed between the manufacturer and the DIBt and is laid down in the context of the factory production control system operated by the manufacturer and deposited with the DIBt.

The results of factory production control shall be recorded and evaluated in accordance with the provisions of the "Control plan"¹⁰. The records include at least the following information:

- designation of the product, the basic materials and components;
- type of control or testing;
- date of manufacture of the product and date of testing of the product or basic materials or components;
- result of control and testing and, if appropriate, comparison with requirements;
- signature of person responsible for factory production control.

The records shall be presented to the notified body involved in continuous surveillance. On request they shall be presented to the DIBt.

3.2.1.2 Other tasks for the manufacturer

For initial type-testing of the ETICS and the components regarding other characteristics than reaction to fire the results of the tests performed as part of the assessment for the ETA shall be used unless there are changes in the production line or plant. In such cases the necessary initial type-testing has to be agreed with the DIBt.

¹⁰ The "Control plan" is a confidential part of the European technical approval and only handed over to the notified body involved in the procedure of attestation of conformity. See section 3.2.2.

The manufacturer shall, on the basis of a contract, involve a body which is notified for the tasks referred to in clause 3.1 in the field of ETICS in order to undertake the actions laid down in clause 3.2.2. For this purpose, the "Control plan"¹⁰ referred to in clauses 3.2.1.1 and 3.2.2 shall be handed over by the manufacturer to the notified bodies involved.

The manufacturer shall make a declaration of conformity, stating that the ETICS is in conformity with the provisions of ETA-06/0028 issued on 8 February 2006.

3.2.2 Tasks for the notified bodies

The notified body shall perform the

- initial inspection of factory and of factory production control,
 - continuous surveillance, assessment and approval of factory production control,
- in accordance with the provisions laid down in the "Control plan"¹⁰.

The notified body shall retain the essential points of its actions referred to above and state the results obtained and conclusions drawn in a written report.

The notified certification body involved by the manufacturer shall issue an EC certificate of conformity of the factory production control stating the conformity with the provisions of this ETA.

In cases where the provisions of the ETA and its "Control plan"¹⁰ are no longer fulfilled the notified certification body shall withdraw the certificate of conformity and inform the DIBt without delay.

3.3 Marking

3.3.1 CE marking

The CE marking shall be affixed on the accompanying commercial document. The letters "CE" shall be followed by the identification number of the notified certification body and be accompanied by the following additional information:

- the name and address of the ETA-holder (legal entity responsible for the manufacture),
- the last two digits of the year in which the CE marking was affixed,
- the number of the EC certificate for the factory production control ,
- the number of the ETA,
- the number of the ETAG,
- the ETICS trade name.

3.3.2 Additional marking

The respective trade name of the individual components of the ETICS shall be given on the packaging.

In addition to the trade name the following information shall be given in the accompanying commercial document and/or on the packaging of the thermal insulation product:

- minimum value of the tensile strength perpendicular to the faces of the insulation product,
- shear modulus of the insulation product.

4 Assumptions under which the fitness of the product for the intended use was favourably assessed

4.1 Manufacturing

The composition and manufacturing process used for the components of the ETICS shall comply with those on which the approval tests were based. Composition and manufacturing process are deposited at the DIBt.

The ETA is issued for the ETICS on the basis of agreed data/information, deposited with the DIBt, which identifies the ETICS that has been assessed and judged. Changes to the ETICS or the components or their production process, which could result in this deposited data/information being incorrect, should be notified to the DIBt before the changes are introduced. DIBt will decide whether or not such changes affect the approval and consequently the validity of the CE marking on the basis of the approval and if so whether further assessment or alterations to the approval shall be necessary.

4.2 Installation, design and execution

4.2.1 General

The wall on which the ETICS is applied shall be sufficiently stable and airtight. Its stiffness shall be large enough to ensure that the ETICS is not subjected to deformations, which could lead to damage.

The requirements given in ETAG 004, chapter 7, have to be considered.

4.2.2 Installation

The ETICS is installed on site. The approval holder is obliged to instruct all those entrusted with the design and execution of the ETICS about the specific conditions of this ETA and all other details necessary for perfect execution.

Only the components whose trade name is given in clause 1.1 and which have the characteristics according to clause 2.3 may be used for the ETICS.

4.2.3 Design

4.2.3.1 Requirements for the substrate

As to the requirements for the substrate and its preparation, ETAG 004, clause 7.2.1 applies.

The substrate for mechanically fixed systems should have a sufficient resistance for the use of anchors according to clause 2.3.2. The conditions of the ETA for the anchor concerned apply.

4.2.3.2 Resistance to wind load

Judging of sufficient resistance to wind load should be on the basis of the resistance of the fixings according to clause 2.2.8.3 and of the characteristic tension resistance of the used anchor according to clause 2.3.2. Taking into account the national safety factors the design values of resistance are determined. The smaller one of the design resistances of the ETICS (R_d) and of the anchor (N_{Rd}) is decisive.

The determined design wind load suction S_d (taking into account the national safety factors) is compared with the design resistance.

4.2.4 Execution

The manufacturer's design and installation instructions, which are part of the technical documentation for this ETA, shall be observed with respect to the installation of the ETICS and drying times of rendering products.

5 Indications to the manufacturer

5.1 Packaging, transport and storage

Packaging of the components has to be such that they are protected against moisture during transport and storage, unless other measures are foreseen by the manufacturer for this purpose.

The components are to be protected against damage.

English translation prepared by DIBt

5.2 Use, maintenance, repair

To the indications on use, maintenance and repair ETAG 004, clause 7.3 applies.

Manfred Klein
Head of Division

beglaubigt:
Praktiknjo

Horizontal profil –(dimensions in millimetres)

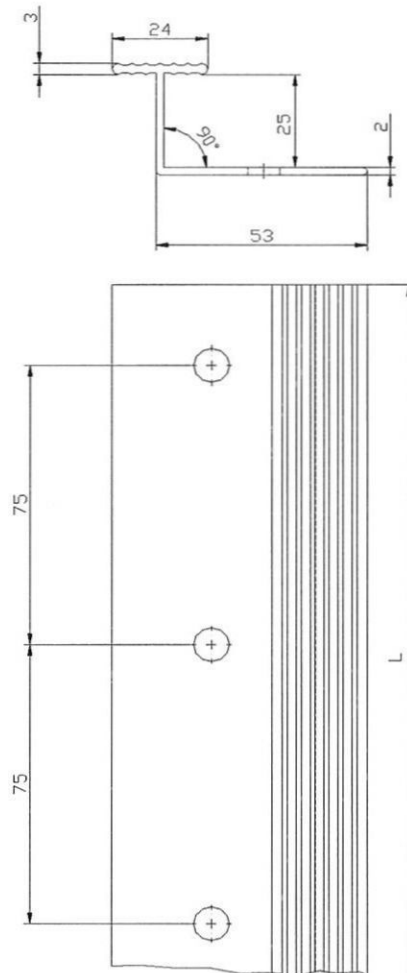

Vertical connection profil (dimensions in millimetres)

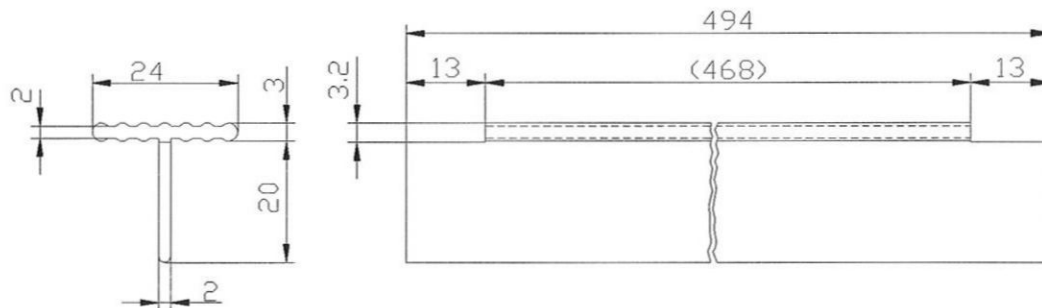

"Lobatherm System P leicht"

Horizontal and vertical PVC profiles

Annex 1