



## European Technical Approval ETA-06/0146

English translation prepared by DIBt - Original version in German language

Handelsbezeichnung <i>Trade name</i>	Ancon 500 Zugstabsystem <i>Ancon 500 Tension Rod System</i>
Zulassungsinhaber <i>Holder of approval</i>	Ancon Building Products President Way, President Park Sheffield S4 7UR GROSSBRITANNIEN
Zulassungsgegenstand und Verwendungszweck <i>Generic type and use of construction product</i>	Vorgefertigtes Zugstabsystem <i>Prefabricated Tension Rod System</i>
Geltungsdauer: <i>Validity:</i>	vom <i>from</i> 20 July 2006 bis <i>to</i> 20 July 2011
verlängert <i>extended</i>	vom <i>from</i> 21 July 2011 bis <i>to</i> 21 July 2016
Herstellwerk <i>Manufacturing plant</i>	Ancon Building Products President Way, President Park Sheffield S4 7UR GROSSBRITANNIEN

Diese Zulassung umfasst  
*This Approval contains*

17 Seiten einschließlich 9 Anhänge  
*17 pages including 9 annexes*

## I LEGAL BASES AND GENERAL CONDITIONS

- 1 This European technical approval is issued by Deutsches Institut für Bautechnik in accordance with:
  - Council Directive 89/106/EEC of 21 December 1988 on the approximation of laws, regulations and administrative provisions of Member States relating to construction products<sup>1</sup>, modified by Council Directive 93/68/EEC<sup>2</sup> and Regulation (EC) N° 1882/2003 of the European Parliament and of the Council<sup>3</sup>;
  - Gesetz über das In-Verkehr-Bringen von und den freien Warenverkehr mit Bauprodukten zur Umsetzung der Richtlinie 89/106/EWG des Rates vom 21. Dezember 1988 zur Angleichung der Rechts- und Verwaltungsvorschriften der Mitgliedstaaten über Bauprodukte und anderer Rechtsakte der Europäischen Gemeinschaften (Bauproduktengesetz - BauPG) vom 28. April 1998<sup>4</sup>, as amended by law of 31 October 2006<sup>5</sup>;
  - Common Procedural Rules for Requesting, Preparing and the Granting of European technical approvals set out in the Annex to Commission Decision 94/23/EC<sup>6</sup>.
- 2 Deutsches Institut für Bautechnik is authorized to check whether the provisions of this European technical approval are met. Checking may take place in the manufacturing plant. Nevertheless, the responsibility for the conformity of the products to the European technical approval and for their fitness for the intended use remains with the holder of the European technical approval.
- 3 This European technical approval is not to be transferred to manufacturers or agents of manufacturers other than those indicated on page 1, or manufacturing plants other than those indicated on page 1 of this European technical approval.
- 4 This European technical approval may be withdrawn by Deutsches Institut für Bautechnik, in particular pursuant to information by the Commission according to Article 5(1) of Council Directive 89/106/EEC.
- 5 Reproduction of this European technical approval including transmission by electronic means shall be in full. However, partial reproduction can be made with the written consent of Deutsches Institut für Bautechnik. In this case partial reproduction has to be designated as such. Texts and drawings of advertising brochures shall not contradict or misuse the European technical approval.
- 6 The European technical approval is issued by the approval body in its official language. This version corresponds fully to the version circulated within EOTA. Translations into other languages have to be designated as such.

<sup>1</sup> Official Journal of the European Communities L 40, 11 February 1989, p. 12  
<sup>2</sup> Official Journal of the European Communities L 220, 30 August 1993, p. 1  
<sup>3</sup> Official Journal of the European Union L 284, 31 October 2003, p. 25  
<sup>4</sup> *Bundesgesetzblatt Teil I 1998*, p. 812  
<sup>5</sup> *Bundesgesetzblatt Teil I 2006*, p. 2407, 2416  
<sup>6</sup> Official Journal of the European Communities L 17, 20 January 1994, p. 34

## II SPECIFIC CONDITIONS OF THE EUROPEAN TECHNICAL APPROVAL

### 1 Definition of product and intended use

#### 1.1 Definition of the construction product

The construction product is a prefabricated tension rod system of different sizes (system sizes) used as a kit. The tension rod system consists of steel or stainless steel bars (tension rods) with external threads, which are connected to each other and to the corresponding structure by special connecting devices. The tension rods are connected to the corresponding structure by steel cast or stainless steel cast fork end connectors with two eye loops and internal thread. The fork end connectors are connected by double shear pin connections to corresponding gusset plates or anchor discs. The tension rods are connected to each other by steel or stainless steel threaded sleeves (couplers).

The tension rod system comprises tension rods, fork end connectors and couplers with metric ISO threads M 6 to M 56 and corresponding anchor discs.

A drawing of the tension rod system and the components as well as the essential dimensions of the components is given in the Annexes to this European technical approval.

#### 1.2 Intended use

The tension rod system is intended for the use in structures with predominantly static loads. Furthermore the installed tension rod system shall be accessible (in order) to facilitate replacement of individual components at any time.

The intended use comprises for instance the suspension of roof structures or vertical glazing as well as bracing and truss structures.

The provisions made in this European technical approval are based on an assumed working life of the tension rod system of 25 years. The indications given on the working life cannot be interpreted as a guarantee given by the producer, but are to be regarded only as a means for choosing the right products in relation to the expected economically reasonable working life of the works.

### 2 Characteristics of product and methods of verification

#### 2.1 Characteristics of product

##### 2.1.1 Dimensions

The dimensions of the components of the tension rod system shall correspond to the drawings given in Annexes 3 to 8. The dimensions and tolerances of the components of the tension rod system not indicated in Annexes 3 to 8 shall correspond to the respective values and information laid down in the technical documentation<sup>7</sup> to this European technical approval.

<sup>7</sup> The technical documentation to this European technical approval is deposited with Deutsches Institut für Bautechnik and, as far as relevant for the tasks of the approved bodies involved in the attestation of conformity procedure is handed over to the approved bodies.

### 2.1.2 Material properties

The material properties of the components of the tension rod system shall correspond to the details given in Annex 2.1 and 2.2. The material characteristics of the components of the tension rod system not indicated in Annex 2.1 and 2.2 shall correspond to the respective values and information laid down in the technical documentation<sup>7</sup> to this European technical approval.

### 2.1.3 Design values of resistance

The design value  $N_{Rd}$  of the tension resistance of the entire tension rod system (tension rods, fork end connectors incl. pins, couplers and anchor discs) is the design tension resistance  $N_{Rd, \text{Tension Rod}}$  of the tension rod multiplied by a reduction factor  $\alpha \leq 1.0$ .

The design value of the tension resistance of the tension rod multiplied by a reduction factor  $\alpha$  shall be determined according to EN 1993-1-1:2005 and EN 1993-1-8:2005 as follows:

$$N_{Rd, \text{Tension Rod}} = \min \{ \alpha_1 \cdot A \cdot f_{y,k} / \gamma_{M1}; \alpha_2 \cdot 0.9 \cdot A_s \cdot f_{u,k} / \gamma_{M2} \}$$

$A$  = minimum cross section of the unthreaded part of the tension rod

$A_s$  = cross section of the threaded part of the tension rod

$f_{y,k}$  =  $R_{p0,2}$  = characteristic value of the yield strength of the tension rod

$R_{p0,2}$  = value of yield strength given in Annex 2.1 or 2.2

$\alpha_1$  = reduction factor (see Table 1)

$f_{u,k}$  =  $R_m$  = characteristic value of the tensile strength of the tension rod

$R_m$  = value of tensile strength given in Annex 2.1 or 2.2

$\alpha_2$  = reduction factor (see Table 1)

$\gamma_{M1}$  = 1.1

$\gamma_{M2}$  = 1.25

Table 1: Reduction factors  $\alpha_1$  and  $\alpha_2$

System size	Steel		Stainless steel	
	$\alpha_1$	$\alpha_2$	$\alpha_1$	$\alpha_2$
M 6	0.83	1.00	0.84	1.00
M 8	0.70	0.82	0.86	1.00
M 10	0.74	0.85	0.86	1.00
M 12	0.76	0.88	0.73	1.00
M 16	0.73	0.80	0.67	0.88
M 20	0.63	0.69	0.66	0.86
M 24	0.68	0.81	0.89	1.00
M 27			0.91	0.99
M 30	0.68	0.73	0.88	0.97
M 36	0.75	0.69	1.00	0.91
M 42	0.73	0.67	1.00	0.91
M 48	0.81	0.73		
M 56	0.83	0.75		

The values given for the partial safety factors  $\gamma_{M1}$  and  $\gamma_{M2}$  are recommended values. They should be used in cases where no values are given in national regulations of the Member State where the tension rod system is used or in the respective National Annex to Eurocode 3 (EN 1993).

#### 2.1.4 Safety in case of fire

The tension rod system is considered to satisfy the requirements of performance class A1 of the characteristic reaction to fire according to EN 13501-1:2007.

### 2.2 Methods of verification

#### 2.2.1 General

The assessment of fitness of the tension rod system for the intended use in relation to the requirements for mechanical resistance and stability, safety in case of fire and safety in use in the sense of the essential requirements No. 1, No. 2 and No. 4 has been made in accordance with section 3.2 of the Common Procedural Rules for Requesting, Preparing and the Granting of European technical approvals set out in the Annex to Commission Decision 94/23/EC<sup>6</sup>.

#### 2.2.2 Essential requirement No. 2: Safety in case of fire

The tension rod system is considered to satisfy the requirements of performance class A 1 of the characteristic reaction to fire, in accordance with the provisions of EC Decision 96/603/EC (as amended) without the need for testing on the basis of its listing in that decision.

#### 2.2.3 Essential requirement No. 1: Mechanical resistance and stability Essential requirement No. 4: Safety in use

In order to verify that the tension resistance of the fork end connectors is higher than the tension resistance of the corresponding tension rods and thus not relevant to the resistance of the entire tension rod system, the characteristic values of the tension resistance of the fork end connectors were assessed by the evaluation of the results of tension tests.

Tension tests were carried out on five system sizes of the steel cast fork end connectors (M 16, M 20, M 24, M 36 and M 56) and on four system sizes of the stainless steel cast fork end connectors (M 16, M 20, M 24 and M 36).

Comparison of characteristic values of tension resistance of the corresponding tension rods, couplers and anchor discs calculated according to EN 1993-1-1:2005 and EN 1993-1-8:2005 with the statistically evaluated test results (characteristic values) has shown that it is sufficient to calculate the tension resistance of the tension rods multiplied by a reduction factor  $\alpha$  in order to determine the tension resistance of the entire tension rod system.

### 3 Evaluation and attestation of conformity and CE marking

#### 3.1 System of attestation of conformity

According to the decision 98/214/EC of the European Commission<sup>8</sup> system 2+ of the attestation of conformity applies.

This system of attestation of conformity is defined as follows:

System 2+: Declaration of conformity of the product by the manufacturer on the basis of:

- (a) Tasks for the manufacturer:
  - (1) initial type-testing of the product;
  - (2) factory production control;
  - (3) testing of samples taken at the factory in accordance with a prescribed test plan.
- (b) Tasks for the approved body:
  - (4) certification of factory production control on the basis of:
    - initial inspection of factory and of factory production control;
    - continuous surveillance, assessment and approval of factory production control.

Note: Approved bodies are also referred to as "notified bodies".

<sup>8</sup> Official Journal of the European Communities/Union L 80 of 18.03.1998

## **3.2 Responsibilities**

### **3.2.1 Tasks for the manufacturer**

#### **3.2.1.1 Factory production control**

The manufacturer shall exercise permanent internal control of production. All the elements, requirements and provisions adopted by the manufacturer shall be documented in a systematic manner in the form of written policies and procedures, including records of results performed. This production control system shall insure that the product is in conformity with this European technical approval.

The manufacturer may only use initial materials stated in the technical documentation of this European technical approval.

The factory production control shall be in accordance with the "control plan" dated 19 July 2006 relating to the European technical approval ETA-06/0146 issued on 20 July 2006, validity extended on 21 July 2011, which is part of the technical documentation of this European technical approval. The "control plan" is laid down in the context of the factory production control system operated by the manufacturer and deposited with Deutsches Institut für Bautechnik.<sup>9</sup>

The results of factory production control shall be recorded and evaluated in accordance with the provisions of the "control plan".

#### **3.2.1.2 Other tasks for the manufacturer**

The manufacturer shall, on the basis of a contract, involve a body which is approved for the tasks referred to in section 3.1 in the field of tension rod systems in order to undertake the actions laid down in section 3.3. For this purpose, the "control plan" referred to in sections 3.2.1.1 and 3.2.2 shall be handed over by the manufacturer to the approved body involved.

The manufacturer shall make a declaration of conformity, stating that the construction product is in conformity with the provisions of this European technical approval.

### **3.2.2 Tasks for the approved bodies**

The approved body shall perform the

- initial inspection of factory and of factory production control,
- continuous surveillance, assessment and approval of factory production control,

in accordance with the provisions laid down in the "control plan".

The approved body shall retain the essential points of its actions referred to above and state the results obtained and conclusions drawn in a written report.

The approved certification body involved by the manufacturer shall issue an EC certificate of conformity of the factory production control stating the conformity with the provisions of this European technical approval.

In cases where the provisions of the European technical approval and its "control plan" are no longer fulfilled the certification body shall withdraw the certificate of conformity and inform the Deutsches Institut für Bautechnik without delay.

## **3.3 CE marking**

The CE marking shall be affixed on each packaging of the tension rod system. The letters "CE" shall be followed by the identification number of the approved certification body, where relevant, and be accompanied by the following additional information:

- the name and address of the producer (legal entity responsible for the manufacture),
- the last two digits of the year in which the CE marking was affixed,
- the number of the EC certificate for the factory production control,

<sup>9</sup> The "control plan" is a confidential part of the European technical approval and only handed over to the approved body involved in the procedure of attestation of conformity.  
See section 3.2.2.

- the number of the European technical approval,
- the name of the product,
- the system size and type (e.g. M 56).

#### **4 Assumptions under which the fitness of the product for the intended use was favourably assessed**

##### **4.1 Manufacturing**

The European technical approval is issued for the product on the basis of agreed data/information, deposited with Deutsches Institut für Bautechnik, which identifies the product that has been assessed and judged. Changes to the product or production process, which could result in this deposited data/information being incorrect, should be notified to Deutsches Institut für Bautechnik before the changes are introduced. Deutsches Institut für Bautechnik will decide whether or not such changes affect the approval and consequently the validity of the CE marking on the basis of the approval and if so whether further assessment or alterations to the approval shall be necessary.

##### **4.2 Installation**

The installation is carried out such that the tension rod system is accessible for repair or maintenance at any time.

The installation is only carried out according to the manufacturer's instructions. The manufacturer hands over the assembly instructions to the assembler. From the assembly instructions it is followed that, prior to installation, all components of the tension rod system shall be checked for their perfect condition and that damaged components shall not be used.

The fork end connectors are not subjected to sudden or impact loads (for instance pins of fork end connectors may not be adjusted by hammer blows).

The minimum thread engagement is marked in an appropriate way. The keeping of the minimum thread engagement "E" and "E2" given in Annexes 3, 6 and 7 is checked by the assembler. How to do this is described in the assembly instructions.

The conformity of the installed tension rod system with the provisions of the ETA is attested by the executing assembler.

##### **4.3 Design**

The loading is predominantly static.

Dimensions, material properties and the thread engagements "E" and "E2" as stated in Annexes 3 to 8 of the ETA are observed.

The tension rod system is not subjected to systematic bending.

The verification concept stated in EN 1990:2002 as well as the values of resistance stated in 2.1 are used for design.

The rules given in EN 1090-2:2008, EN 1993-1-4:2006 and EN ISO 12944:1998 are taken into account.

Design is carried out by the designer of the structure experienced in the field of steel structures.



## 5 Indications to the manufacturer

The manufacturer shall ensure that the information on the specific conditions according to 1, 2, 4.2 and 4.3 (including Annexes referred to) is given to those who are concerned. This information may be given by reproduction of the European technical approval.

In addition all essential installation data (e.g. minimum thread engagement "E" and "E2" according to Annexes 3, 6 and 7) shall be shown clearly on the package and/or on an enclosed instruction sheet, preferably using illustration(s).

The prefabricated tension rod system shall be packaged and delivered as a complete unit only (tension rods, fork end connectors incl. pins, couplers and anchor discs).

Georg Feistel  
Head of Department

*beglaubigt:*  
Spohn



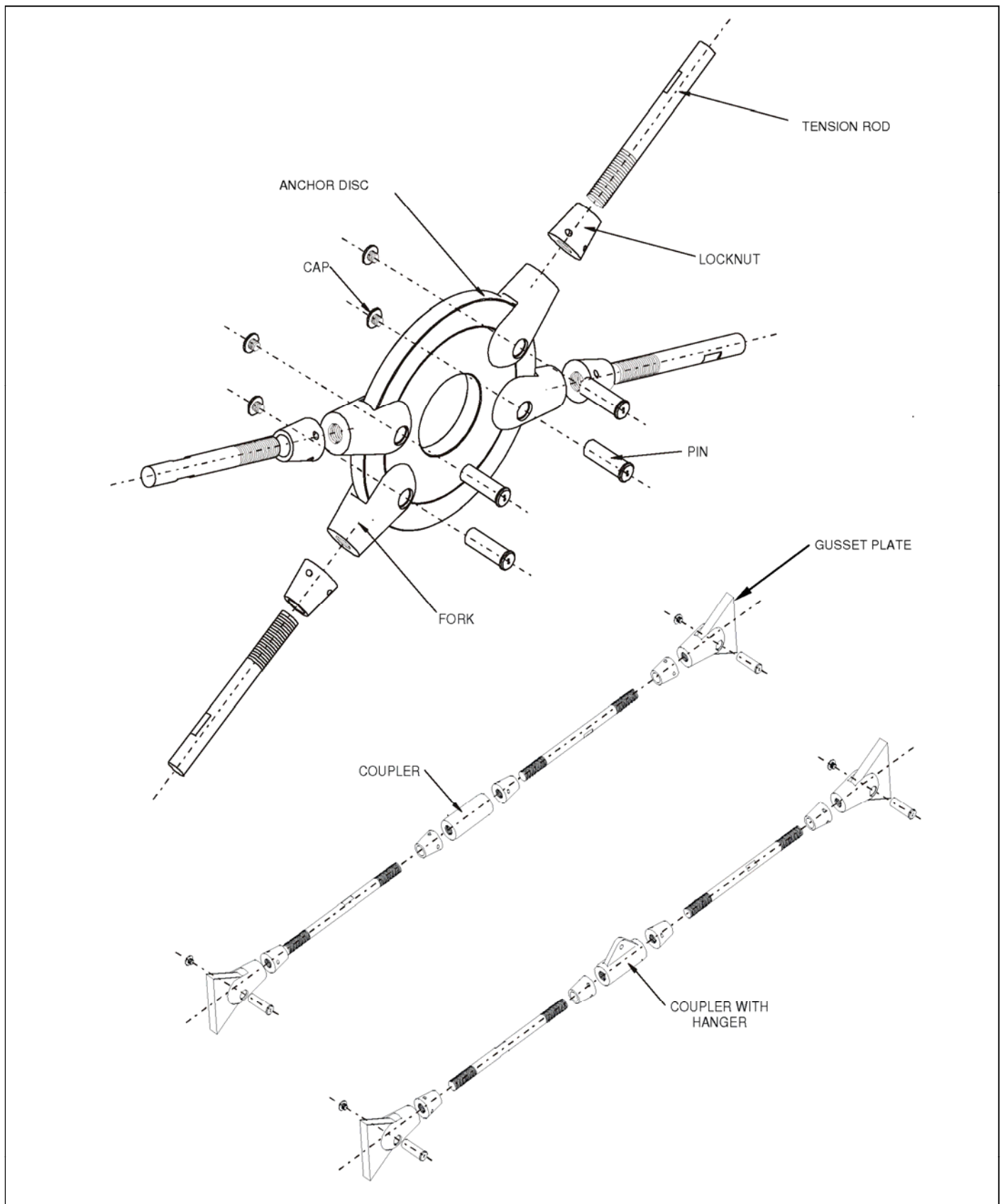

Ancon 500 Tension Rod System

System, components

Annex 1

Component	System Size	Material		Techn. delivery condition	Mechanical Properties (Minimum Values)			
		Material or Steel Grade	Material Number		Yield strength $R_{p0.2}$ [N/mm <sup>2</sup> ]	Tensile strength $R_m$ [N/mm <sup>2</sup> ]	Elongation $A_5$ [%]	Charpy impact energy ISO-V [J / °C]
Fork and Locknut	M6 – M12	GS-20Mn5	acc. to technical documentation <sup>1)</sup>	acc. to technical documentation <sup>1)</sup>	355	510	20	27 / -20
	M16 – M56				250	400		
Tension Rod	M6 – M56	080M40	acc. to technical documentation <sup>1)</sup>	acc. to technical documentation <sup>1)</sup>	500	650	16	27 / -20
		C40	1.0511	EN 10083-1				
		C40E	1.1186	EN 10083-1				
Pin and Cap	M6 – M56	C45E	1.1191	EN 10083-1	350	610	14	27 / -20
		C45	1.0503	EN 10083-1				
Anchor disc	M6 – M56	S355JR	1.0045	EN 10025-2	355	490	21	27 / -20
Coupler	M6 – M12	S355J2	1.0570	EN 10025-2	355	510	20	27 / -20
	M16 – M56				250	400		

<sup>1)</sup> The technical documentation is deposited at Deutsches Institut für Bautechnik.

Ancon 500 Tension Rod System  
Material properties of steel components

Annex 2.1

Component	System Size	Material		Techn. delivery condition	Mechanical Properties (Minimum Values)					
		Material	Material Number		Yield strength $R_{p0.2}$ [N/mm <sup>2</sup> ]	Tensile strength $R_m$ [N/mm <sup>2</sup> ]	Elongation $A_5$ [%]	Charpy impact energy ISO-V [J / °C]		
Fork and Locknut	M6 – M12	X2CrNiMoN22-5-3	1.4462	EN 10283 <sup>1)</sup>	355	510	25	27 / -20		
		GX2CrNiMoN22-5-3	1.4470	EN 10283						
	M16 – M42	X2CrNiMoN22-5-3	1.4462	EN 10283 <sup>1)</sup>	250	400	25			
		GX2CrNiMoN22-5-3	1.4470	EN 10283						
Tension Rod	M6, M8	X5CrNiMo17-12-2	1.4401	EN 10088-3	470	620	40			
		X2CrNiMo17-12-2	1.4404							
		X5CrNiMo17-12-2	1.4401							
	M10	X2CrNiMo17-12-2	1.4404		500	650	40			
	M12 – M20	X2CrNiMoN22-5-3	<b>1.4462</b>					780	850	20
	M24 – M30									
	M36, M42									
Pin and Cap	M6 – M42	X5CrNiMo17-12-2	1.4401	EN 10088-3	225	520	40			
		X2CrNiMo17-12-2	1.4404							
Anchor disc	M6 – M42	X2CrNiMoN22-5-3	1.4462	EN 10088-2	445	640	25	27 / -20		
Coupler	M6 – M12	X2CrNiMoN22-5-3	1.4462	EN 10088-2	355	510	25	27 / -20		
	M16 – M24				250					
	M27 – M42					400				

<sup>1)</sup> 1.4462 is not covered by EN 10283. In addition to the structure and the mechanical properties the indications given in EN 10283 for 1.4470 apply for 1.4462 accordingly

Ancon 500 Tension Rod System  
Material properties of stainless steel components

Annex 2.2

English translation prepared by DIBt

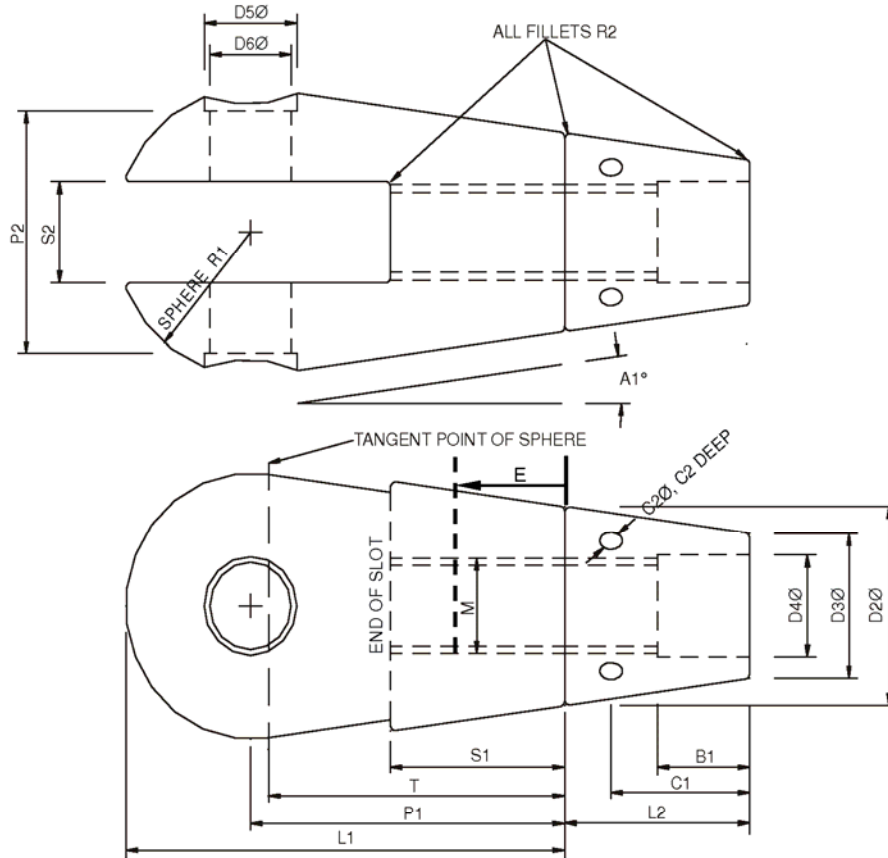

System size	M6	M8	M10	M12	M16	M20	M24	M27 <sup>1)</sup>	M30	M36	M42	M48	M56
A1 [°]	7.19	7.36	7.70	7.37	7.82	8.38	7.44	7.52	7.90	7.78	7.66	7.61	7.66
B1 [mm]	11.50	12.50	15.00	18.20	20.00	21.00	27.00	30.00	32.50	35.50	42.00	46.50	54.00
C1 [mm]	9.30	9.83	14.80	10.87	24.75	16.29	37.55	44.06	47.77	54.68	57.97	56.09	89.94
C2 [mm]	2.00	2.00	3.00	3.00	4.50	4.50	5.50	5.50	5.50	6.50	6.50	6.50	8.50
D2 [mm]	12.44	15.85	19.95	23.78	33.27	41.40	48.99	55.61	62.16	74.46	87.00	99.00	116.00
D3 [mm]	8.40	11.20	14.00	16.80	24.20	30.20	36.20	41.10	45.50	55.05	64.41	74.05	86.96
D4 [mm]	6.50	8.50	10.50	12.50	17.00	21.00	26.00	28.00	31.00	37.00	43.00	49.00	57.00
D5 [mm]	8.00	9.50	11.00	13.50	16.50	21.00	24.50	28.00	30.00	36.75	42.75	50.75	59.75
D6 [mm]	6.50	7.50	9.50	11.50	14.50	18.50	21.50	24.50	26.50	30.50	35.50	42.50	50.50
L1 [mm]	32.98	40.55	49.39	59.65	78.19	93.86	114.51	128.73	139.89	169.11	196.04	224.17	260.91
L2 [mm]	16.00	18.00	22.00	27.00	33.00	38.00	49.00	55.00	60.00	71.00	84.00	93.00	108.00
P1 [mm]	24.60	29.95	35.95	43.70	56.00	66.00	82.00	92.00	99.00	119.00	138.00	158.00	184.00
P2 [mm]	14.82	19.13	24.99	29.40	40.60	51.87	61.19	68.19	77.49	92.82	106.36	119.54	138.71
R1 [mm]	9.25	11.70	14.70	17.40	24.10	30.10	34.90	39.60	44.40	53.00	61.50	70.00	82.00
R2 [mm]	0.50	0.50	0.50	0.50	0.75	0.75	1.00	1.50	1.50	1.50	2.00	2.00	2.50
S1 [mm]	15.00	17.00	20.00	25.00	31.00	36.00	46.00	52.00	55.00	63.25	72.75	82.50	99.00
S2 [mm]	6.60	8.70	10.70	12.70	17.00	21.00	23.00	26.00	31.00	31.00	36.00	41.00	51.00
T [mm]	23.44	28.45	33.98	41.47	52.72	61.61	77.48	86.82	92.89	111.82	129.81	148.72	173.07
E [mm] minimum thread engagement	5.00	6.50	8.00	10.20	13.00	16.00	19.00	22.00	24.00	29.00	34.00	38.00	45.00

<sup>1)</sup> System size M27 is only available for the stainless steel System of Annex 2.2.

Ancon 500 Tension Rod System

Dimensions of forks and locknuts

Annex 3

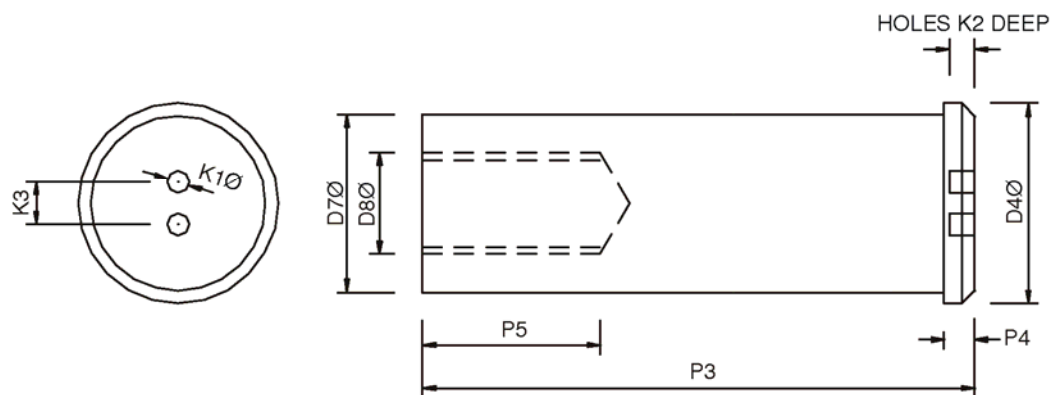

ALL CHAMFERS P7

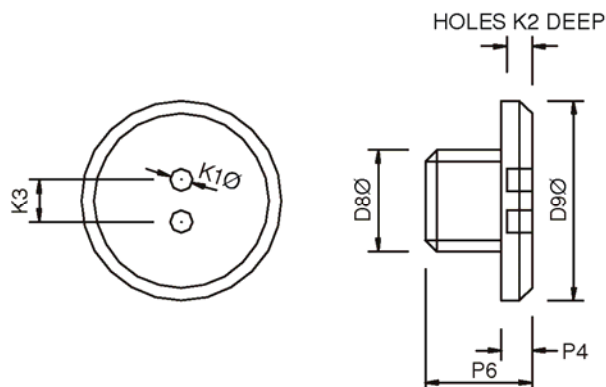

System-size	M6	M8	M10	M12	M16	M20	M24	M27 <sup>1)</sup>	M30	M36	M42	M48	M56
D7 [mm]	6.00	7.00	9.00	11.00	14.00	18.00	21.00	24.00	26.00	30.00	35.00	42.00	50.00
D8 [mm]	M4	M5	M6	M8	M8	M10	M12	M12	M12	M12	M12	M12	M12
D9 [mm]	7.25	8.75	10.25	12.75	15.75	20.25	23.75	27.25	29.50	36.00	42.00	50.00	59.00
K1 [mm]	1.59	1.59	1.59	1.59	1.76	1.76	2.18	2.18	2.18	2.18	2.18	2.18	2.18
K2 [mm]	1.00	1.00	1.00	1.00	2.00	2.00	2.20	2.20	2.20	2.20	2.20	2.20	2.20
K3 [mm]	2.35	2.35	2.35	2.35	3.34	3.34	4.47	4.70	4.70	4.70	4.70	4.70	4.70
P3 [mm]	16.57	21.13	26.99	32.05	43.90	55.87	65.19	73.19	82.94	99.27	114.42	129.74	151.10
P4 [mm]	1.25	1.50	1.50	2.00	2.40	3.00	3.00	4.00	4.00	5.00	6.00	8.00	10.00
P5 [mm]	8.00	11.00	14.00	15.00	9.00	12.00	12.00	16.00	16.00	25.00	25.00	32.00	32.00
P6 [mm]	7.25	10.50	12.50	14.00	8.40	11.00	11.00	14.00	14.00	15.00	16.00	20.00	22.00
P7 [mm]	0.50	0.75	0.75	1.00	1.00	1.50	1.50	2.00	2.00	3.00	3.00	4.00	5.00

<sup>1)</sup> System size M27 is only available for the stainless steel System of Annex 2.2.

Ancon 500 Tension Rod System

Dimensions of pins and caps

Annex 4

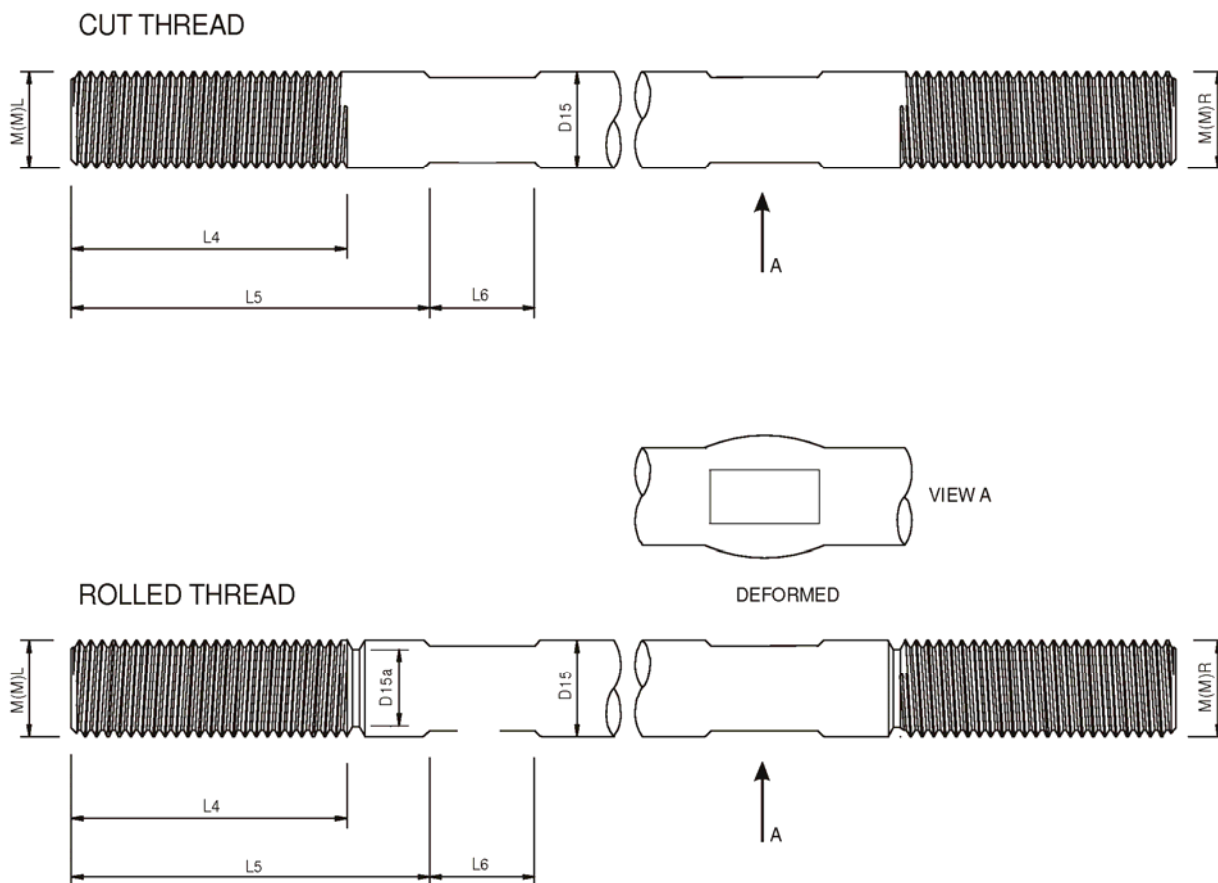

System-size	M6	M8	M10	M12	M16	M20	M24	M27 <sup>1)</sup>	M30	M36	M42	M48	M56
D15 [mm]	6.00	8.00	10.00	12.00	16.00	20.00	25.0 <sup>2)</sup> 24.0 <sup>3)</sup>	27.00	30.00	35.00	40.00	45.00	55.00
D15a [mm]	-	-	-	-	-	-	-	-	-	33.30	39.00	44.45	52.30
L4 [mm]	21.00	24.50	30.00	37.00	46.00	54.00	68.00	77.00	84.00	100.0	118.0	131.0	153.0
L5 [mm]	76.00	80.00	85.00	92.00	101.0	109.0	137.0	156.0	165.0	198.0	232.0	264.0	314.0
L6 [mm]	12.00	12.00	12.00	20.00	20.00	20.00	20.00	30.00	30.00	30.00	30.00	50.00	50.00
THREAD	Cut									Rolled	Rolled	Rolled	Rolled
<sup>1)</sup>	System size M27 is only available for the stainless steel System of Annex 2.2.												
<sup>2)</sup>	STEEL												
<sup>3)</sup>	STAINLESS STEEL												

Ancon 500 Tension Rod System

Dimensions of tension rods

Annex 5

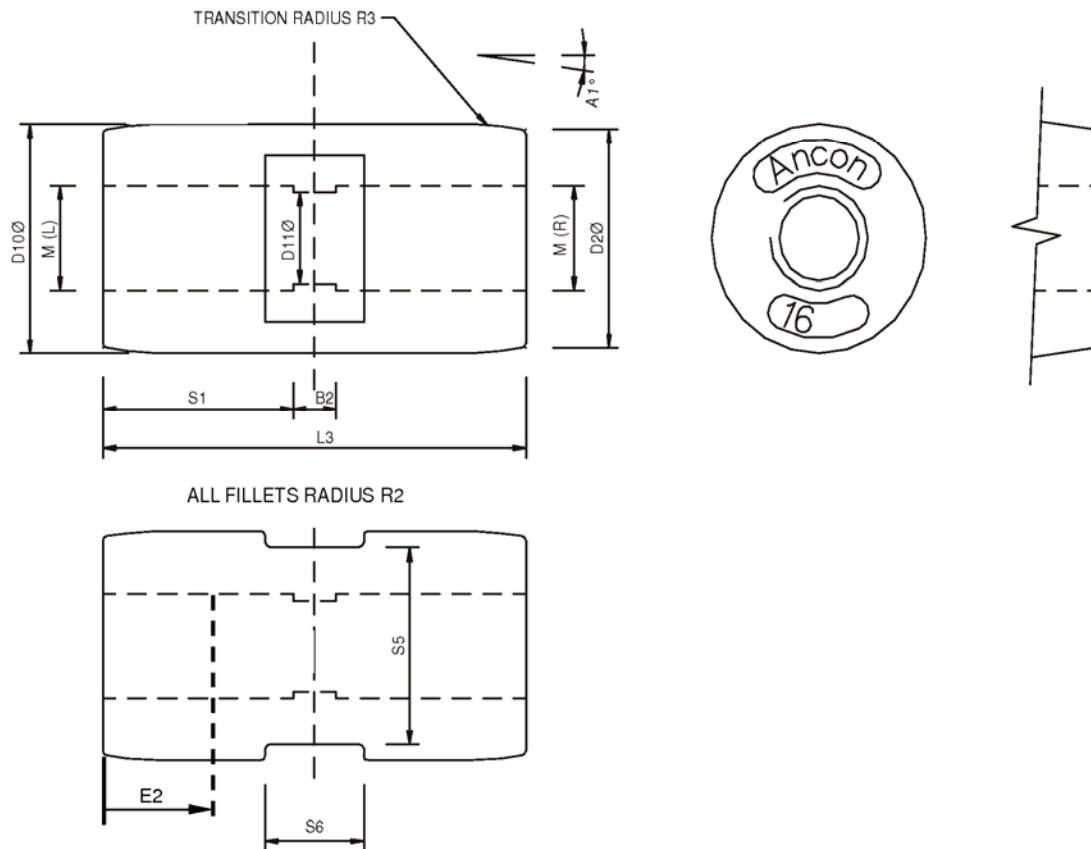

System-size	M6	M8	M10	M12	M16	M20	M24	M27 <sup>1)</sup>	M30	M36	M42	M48	M56
A1 [°]	7.19	7.36	7.70	7.37	7.82	8.38	7.44	7.52	7.90	7.78	7.66	7.61	7.66
B2 [mm]	3.00	4.00	5.00	6.00	21.00	10.00	12.00	13.50	15.00	18.00	21.00	24.00	28.00
D2 [mm]	12.44	15.85	19.95	23.78	33.27	41.40	48.99	55.61	62.16	74.46	87.00	99.00	116.00
D10 [mm]	13.00	17.00	21.00	25.00	35.00	43.00	52.00	58.00	65.00	78.00	90.00	103.00	121.00
D11 [mm]	5.00	6.80	8.50	10.20	14.00	17.50	21.00	24.00	26.50	32.00	37.50	43.00	50.50
L3 [mm]	33.00	38.00	45.00	56.00	83.00	82.00	104.00	117.50	125.00	144.50	166.50	189.00	226.00
R2 [mm]	0.50	0.50	0.50	0.50	0.75	0.75	1.00	1.50	1.50	1.50	2.00	2.00	2.50
R3 [mm]	13.00	17.00	21.00	25.00	35.00	43.00	49.00	58.00	65.00	65.00	70.00	80.00	90.00
S1 [mm]	15.00	17.00	20.00	25.00	31.00	36.00	46.00	52.00	55.00	63.25	72.75	82.50	99.00
S5 [mm]	10.00	13.00	17.00	19.00	30.00	36.00	46.00	46.00	55.00	65.00	75.00	85.00	95.00
S6 [mm]	6.00	8.00	10.00	12.00	16.00	19.00	24.00	24.00	29.00	34.00	38.00	45.00	51.00
E2 [mm] minimum thread engagement	5.00	6.50	8.00	10.20	13.00	16.00	19.00	22.00	24.00	29.00	34.00	38.00	45.00

<sup>1)</sup> System size M27 is only available for the stainless steel System of Annex 2.2.

Ancon 500 Tension Rod System

Dimensions of couplers without hanger

Annex 6



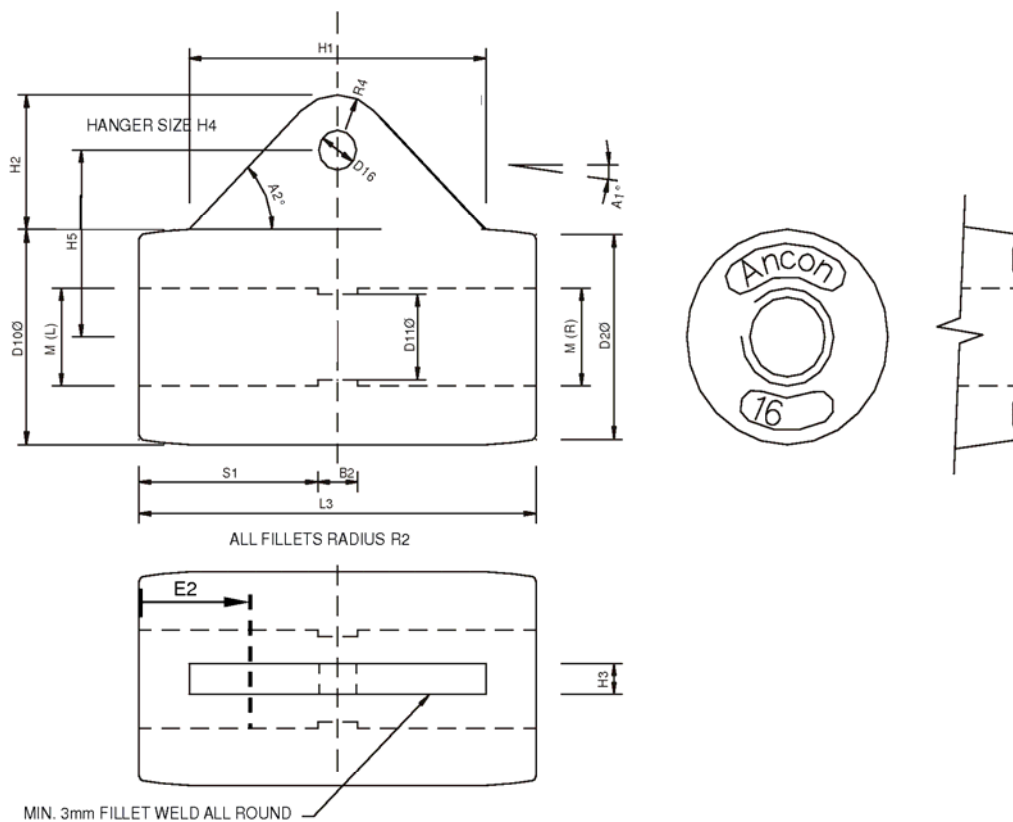

System-size	M16	M20	M24	M27 <sup>1)</sup>	M30	M36	M42	M48	M56
A1 [°]	7.82	8.38	7.44	7.52	7.90	7.78	7.66	7.61	7.66
A2 [°]	45.00	45.00	45.00	45.00	45.00	45.00	45.00	45.00	45.00
B2 [mm]	21.00	10.00	12.00	13.50	15.00	18.00	21.00	24.00	28.00
B3 [mm]	21.00	17.00	22.00	24.00	26.00	29.0	34.00	39.00	45.50
D2 [mm]	33.27	41.40	48.99	55.61	62.16	74.46	87.00	99.00	116.00
D10 [mm]	35.00	43.00	52.00	58.00	65.00	78.00	90.00	103.00	121.00
D11 [mm]	14.00	17.50	21.00	24.00	26.50	32.00	37.50	43.00	50.50
D16 [mm]	7.50	7.50	7.50	9.50	9.50	9.50	9.50	11.50	11.50
H1 [mm]	64.83	64.83	80.10	91.78	95.57	113.49	138.64	154.37	176.61
H2 [mm]	27.45	27.45	35.08	39.68	41.57	50.53	63.11	69.73	80.85
H3 [mm]	8.00	8.00	8.00	10.00	10.00	10.00	10.00	12.00	12.00
H4 [mm]	8	8	8	10	10	10	10	12	12
H5 [mm]	32.95	37.00	49.00	53.70	59.10	74.50	93.10	103.20	123.40
L3 [mm]	83.00	82.00	104.00	117.50	125.00	144.50	166.50	189.00	226.00
R2 [mm]	0.75	0.75	1.00	1.50	1.50	1.50	2.00	2.00	2.50
R3 [mm]	35.00	43.00	49.00	58.00	65.00	65.00	70.00	80.00	90.00
R4 [mm]	12.00	12.00	12.00	15.00	15.00	15.00	15.00	18.00	18.00
S1 [mm]	31.00	36.00	46.00	52.00	55.00	63.25	72.75	82.50	99.00
E2 [mm] minimum thread engagement	13.00	16.00	19.00	22.00	24.00	29.00	34.00	38.00	45.00

<sup>1)</sup> System size M27 is only available for the stainless steel System of Annex 2.2.

Ancon 500 Tension Rod System

Dimensions of couplers with hanger

Annex 7

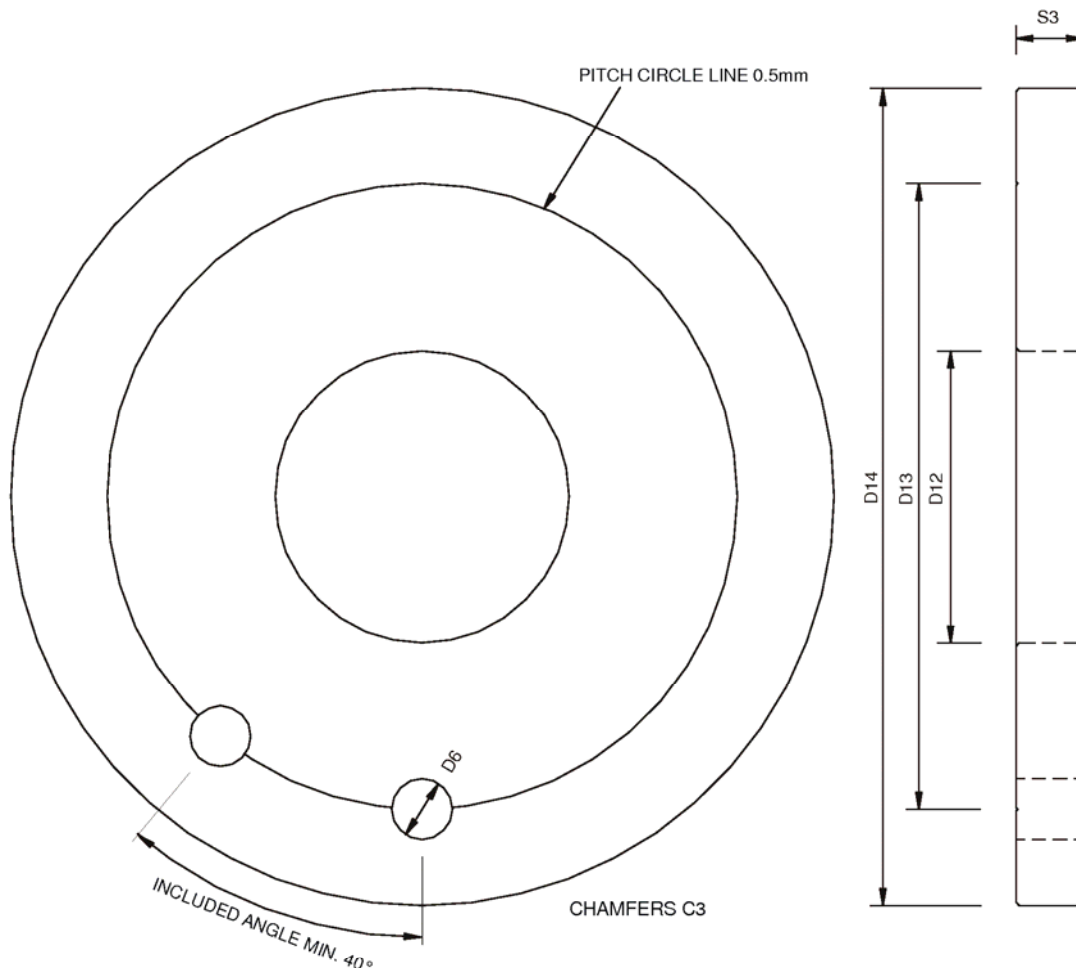

System-size	M6	M8	M10	M12	M16	M20	M24	M27 <sup>1)</sup>	M30	M36	M42	M48	M56
C3 [mm]	0.50	0.50	0.50	0.50	0.75	0.75	1.00	1.50	1.50	1.50	2.00	2.00	2.50
D6 [mm]	6.50	7.50	9.50	11.50	14.50	18.50	21.50	24.50	26.50	30.50	35.50	42.50	50.50
D12 [mm]	27.00	37.00	46.00	56.00	70.00	94.00	106.00	120.00	132.00	156.00	182.00	212.00	248.00
D13 [mm]	59.00	76.00	93.00	112.00	150.00	184.00	212.00	239.00	269.00	318.00	367.00	416.00	488.00
D14 [mm]	77.00	100.00	123.00	148.00	196.00	242.00	282.00	317.00	355.00	425.50	493.50	563.00	654.00
S3 [mm]	6.00	8.00	10.00	12.00	16.00	20.00	22.00	25.00	31.00	30.00	35.00	40.00	50.00

<sup>1)</sup> System size M27 is only available for the stainless steel System of Annex 2.2.

Ancon 500 Tension Rod System

Dimensions of anchor discs

Annex 8