



European Technical Approval ETA-07/0084

English translation prepared by DIBt - Original version in German language

Handelsbezeichnung <i>Trade name</i>	ATRION Betonschraube ABS-W/-WII/-R und -HCR <i>ATRION Concrete Screw ABS-W/-WII/-R and -HCR</i>
Zulassungsinhaber <i>Holder of approval</i>	Adolf Würth GmbH & Co. KG Reinhold-Würth-Straße 12 -17 74653 Künzelsau DEUTSCHLAND
Zulassungsgegenstand und Verwendungszweck <i>Generic type and use of construction product</i>	Betonschraube aus galvanisch verzinktem und nichtrostendem Stahl in den Größen 8, 10, 12 und 14 zur Verankerung im Beton <i>Concrete screw made of galvanised steel and stainless steel of sizes 8, 10, 12 and 14 for use in concrete</i>
Geltungsdauer: <i>Validity:</i>	vom <i>from</i> 31 October 2011 bis <i>to</i> 18 February 2016
Herstellwerk <i>Manufacturing plant</i>	Werk C, Deutschland

Diese Zulassung umfasst
This Approval contains

14 Seiten einschließlich 6 Anhänge
14 pages including 6 annexes

Diese Zulassung ersetzt
This Approval replaces

ETA-07/0084 mit Geltungsdauer vom 19.05.2011 bis 18.02.2016
ETA-07/0084 with validity from 19.05.2011 to 18.02.2016

I LEGAL BASES AND GENERAL CONDITIONS

- 1 This European technical approval is issued by Deutsches Institut für Bautechnik in accordance with:
 - Council Directive 89/106/EEC of 21 December 1988 on the approximation of laws, regulations and administrative provisions of Member States relating to construction products¹, modified by Council Directive 93/68/EEC² and Regulation (EC) N° 1882/2003 of the European Parliament and of the Council³;
 - Gesetz über das In-Verkehr-Bringen von und den freien Warenverkehr mit Bauprodukten zur Umsetzung der Richtlinie 89/106/EWG des Rates vom 21. Dezember 1988 zur Angleichung der Rechts- und Verwaltungsvorschriften der Mitgliedstaaten über Bauprodukte und anderer Rechtsakte der Europäischen Gemeinschaften (Bauproduktengesetz - BauPG) vom 28. April 1998⁴, as amended by law of 31 October 2006⁵;
 - Common Procedural Rules for Requesting, Preparing and the Granting of European technical approvals set out in the Annex to Commission Decision 94/23/EC⁶.
- 2 Deutsches Institut für Bautechnik is authorized to check whether the provisions of this European technical approval are met. Checking may take place in the manufacturing plant. Nevertheless, the responsibility for the conformity of the products to the European technical approval and for their fitness for the intended use remains with the holder of the European technical approval.
- 3 This European technical approval is not to be transferred to manufacturers or agents of manufacturers other than those indicated on page 1, or manufacturing plants other than those indicated on page 1 of this European technical approval.
- 4 This European technical approval may be withdrawn by Deutsches Institut für Bautechnik, in particular pursuant to information by the Commission according to Article 5(1) of Council Directive 89/106/EEC.
- 5 Reproduction of this European technical approval including transmission by electronic means shall be in full. However, partial reproduction can be made with the written consent of Deutsches Institut für Bautechnik. In this case partial reproduction has to be designated as such. Texts and drawings of advertising brochures shall not contradict or misuse the European technical approval.
- 6 The European technical approval is issued by the approval body in its official language. This version corresponds fully to the version circulated within EOTA. Translations into other languages have to be designated as such.

¹ Official Journal of the European Communities L 40, 11 February 1989, p. 12
² Official Journal of the European Communities L 220, 30 August 1993, p. 1
³ Official Journal of the European Union L 284, 31 October 2003, p. 25
⁴ *Bundesgesetzblatt Teil I 1998*, p. 812
⁵ *Bundesgesetzblatt Teil I 2006*, p. 2407, 2416
⁶ Official Journal of the European Communities L 17, 20 January 1994, p. 34

II SPECIFIC CONDITIONS OF THE EUROPEAN TECHNICAL APPROVAL

1 Definition of product and intended use

1.1 Definition of the construction product

The ATRION Concrete Screw ABS is an anchor made of zinc-plated steel respectively steel with zinc flake coating (designated as ABS-W or ABS-WII) or stainless steel (designated as ABS-R) or high corrosion resistant steel (designated as ABS-HCR) of sizes 8, 10, 12 and 14. The anchor is screwed into a predrilled cylindrical drill hole. The special thread of the anchor cuts an internal thread into the member while setting. The anchorage is characterised by mechanical interlock in the special thread.

An illustration of the product and intended use is given in Annex 1.

1.2 Intended use

The anchor is intended to be used for anchorages for which requirements for mechanical resistance and stability and safety in use in the sense of the Essential Requirements 1 and 4 of Council Directive 89/106 EEC shall be fulfilled and failure of anchorages made with these products would cause risk to human life and/or lead to considerable economic consequences.

The anchor may be used for anchorages with requirements related to resistance to fire.

The anchor is to be used only for anchorages subject to static or quasi-static loading in reinforced or unreinforced normal weight concrete of strength classes C20/25 at minimum and C50/60 at most according to EN 206:2000-12.

The anchor may be anchored in cracked and non-cracked concrete.

The anchor may also be set in drill holes filled with injection mortar ATRION AVM-S.

Anchor made of zinc-plated steel respectively made of steel with zinc flake coating:

The ATRION Concrete screw ABS-W or ABS-WII may only be used in structures subject to dry internal conditions.

Anchor made of stainless steel:

The ATRION Concrete screw ABS-R may be used in structures subject to dry internal conditions and also in structures subject to external atmospheric exposure (including industrial and marine environment), or exposure in permanently damp internal conditions, if no particular aggressive conditions exist. Such particular aggressive conditions are e.g. permanent, alternating immersion in seawater or the splash zone of seawater, chloride atmosphere of indoor swimming pools or atmosphere with extreme chemical pollution (e.g. in desulphurization plants or road tunnels where de-icing materials are used).

Anchor made of high corrosion resistant steel:

The ATRION Concrete screw ABS-HCR may be used in structures subject to dry internal conditions and also in structures subject to external atmospheric exposure, in permanently damp internal conditions or in other particular aggressive conditions. Such particular aggressive conditions are e.g. permanent, alternating immersion in seawater or the splash zone of seawater, chloride atmosphere of indoor swimming pools or atmosphere with chemical pollution (e.g. in desulphurization plants or road tunnels where de-icing materials are used).

The provisions made in this European technical approval are based on an assumed working life of the anchor of 50 years. The indications given on the working life cannot be interpreted as a guarantee given by the producer, but are to be regarded only as a means for choosing the right products in relation to the expected economically reasonable working life of the works.

2 Characteristics of the product and methods of verification

2.1 Characteristics of product

The anchor corresponds to the drawings and information given in Annex 2. The characteristic material values, dimensions and tolerances of the anchor not indicated in Annex 2 shall correspond to the respective values laid down in the technical documentation⁷ of this European technical approval.

Regarding the requirements concerning safety in case of fire it is assumed that the ATRION Concrete Screw ABS meets the requirements of class A1 in relation to reaction to fire in accordance with the stipulations of the Commission decision 96/603/EC, amended by 2000/605/EC.

The characteristic values for the design of the anchorages are given in Annexes 4 and 5.

The characteristic values for the design of the anchorages regarding resistance to fire are given in Annex 6. They are valid for use in a system that is required to provide a specific fire resistance class.

Each anchor shall be marked with the identifying mark of the producer, the anchor type, the diameter and the length of the anchor according to Annex 2.

The anchor shall only be packaged and supplied as a complete unit.

2.2 Methods of verification

The assessment of fitness of the anchor for the intended use in relation to the requirements for mechanical resistance and stability and safety in use in the sense of the Essential Requirements 1 and 4 has been made in accordance with the "Guideline for European technical approval of Metal Anchors for Use in Concrete", Part 1 "Anchors in general" and Part 3 "Undercut anchors", on the basis of Option 1.

The assessment of the anchor for the intended use in relation to the requirements for resistance to fire has been made in accordance with the Technical Report TR 020 "Evaluation of anchorages in concrete concerning resistance to fire".

In addition to the specific clauses relating to dangerous substances contained in this European technical approval, there may be other requirements applicable to the products falling within its scope (e.g. transposed European legislation and national laws, regulations and administrative provisions). In order to meet the provisions of the Construction Products Directive, these requirements need also to be complied with, when and where they apply.

⁷

The technical documentation of this European technical approval is deposited at the Deutsches Institut für Bautechnik and, as far as relevant for the tasks of the approved bodies involved in the attestation of conformity procedure, is handed over to the approved bodies.

3 Evaluation and attestation of conformity and CE marking

3.1 System of attestation of conformity

According to the decision 96/582/EG of the European Commission⁸ the system 2(i) (referred to as system 1) of attestation of conformity applies.

This system of attestation of conformity is defined as follows:

System 1: Certification of the conformity of the product by an approved certification body on the basis of:

- (a) Tasks for the manufacturer:
 - (1) factory production control;
 - (2) further testing of samples taken at the factory by the manufacturer in accordance with a prescribed control plan;
- (b) Tasks for the approved body:
 - (3) initial type-testing of the product;
 - (4) initial inspection of factory and of factory production control;
 - (5) continuous surveillance, assessment and approval of factory production control.

Note: Approved bodies are also referred to as "notified bodies".

3.2 Responsibilities

3.2.1 Tasks of the manufacturer

3.2.1.1 Factory production control

The manufacturer shall exercise permanent internal control of production. All the elements, requirements and provisions adopted by the manufacturer shall be documented in a systematic manner in the form of written policies and procedures, including records of results performed. This production control system shall insure that the product is in conformity with this European technical approval.

The manufacturer may only use initial / raw / constituent materials stated in the technical documentation of this European technical approval.

The factory production control shall be in accordance with the control plan which is part of the technical documentation of this European technical approval. The control plan is laid down in the context of the factory production control system operated by the manufacturer and deposited at Deutsches Institut für Bautechnik.⁹

The results of factory production control shall be recorded and evaluated in accordance with the provisions of the control plan.

3.2.1.2 Other tasks of manufacturer

The manufacturer shall, on the basis of a contract, involve a body which is approved for the tasks referred to in section 3.1 in the field of anchors in order to undertake the actions laid down in section 3.2.2. For this purpose, the control plan referred to in sections 3.2.1.1 and 3.2.2 shall be handed over by the manufacturer to the approved body involved.

The manufacturer shall make a declaration of conformity, stating that the construction product is in conformity with the provisions of this European technical approval.

⁸ Official Journal of the European Communities L 254 of 08.10.1996.

⁹ The control plan is a confidential part of the documentation of the European technical approval, but not published together with the European technical approval and only handed over to the approved body involved in the procedure of attestation of conformity.
See section 3.2.2.

3.2.2 Tasks of approved bodies

The approved body shall perform the

- initial inspection of factory and of factory production control,
- continuous surveillance, assessment and approval of factory production control, in accordance with the provisions laid down in the control plan.

The approved body shall retain the essential points of its actions referred to above and state the results obtained and conclusions drawn in a written report.

The approved certification body involved by the manufacturer shall issue an EC certificate of conformity of the factory production control stating the conformity with the factory production control of this European technical approval.

In cases where the provisions of the European technical approval and its control plan are no longer fulfilled the certification body shall withdraw the certificate of conformity and inform Deutsches Institut für Bautechnik without delay.

3.3 CE marking

The CE marking shall be affixed on each packaging of the anchors. The letters "CE" shall be followed by the identification number of the approved certification body, where relevant, and be accompanied by the following additional information:

- the name and address of the producer (legal entity responsible for the manufacturer),
- the last two digits of the year in which the CE marking was affixed,
- the number of the EC certificate for the factory production control,
- the number of the European technical approval,
- the number of the guideline for European technical approval,
- use category (ETAG 001-1, Option 1),
- size.

4 Assumptions under which the fitness of the product for the intended use was favourably assessed

4.1 Manufacturing

The European technical approval is issued for the product on the basis of agreed data/information, deposited with Deutsches Institut für Bautechnik, which identifies the product that has been assessed and judged. Changes to the product or production process, which could result in this deposited data/information being incorrect, should be notified to Deutsches Institut für Bautechnik before the changes are introduced. Deutsches Institut für Bautechnik will decide whether or not such changes affect the European technical approval and consequently the validity of the CE marking on the basis of the European technical approval and if so whether further assessment or alterations to the European technical approval shall be necessary.

4.2 Design of anchorages

The fitness of the anchor for the intended use is given under the following conditions:

The anchorages are designed in accordance with the "Guideline for European technical approval of Metal Anchors for Use in Concrete", Annex C, Method A under the responsibility of an engineer experienced in anchorages and concrete work.

Verifiable calculation notes and drawings are prepared taking account of the loads to be anchored.

The position of the anchor is indicated on the design drawings (e.g. position of the anchor relative to reinforcement or to supports, in cracked or non-cracked concrete, etc.).

The design of anchorages under fire exposure has to consider the conditions given in the Technical Report TR 020 "Evaluation of anchorages in concrete concerning resistance to fire". The relevant characteristic values are given in Annex 6, Table 8 and 9. The design method covers anchors with a fire attack from one side only. If the fire attack is from more than one side, the design method may be taken only, if the edge distance of the anchor is $c \geq 300$ mm.

4.3 Installation of anchors

The fitness for use of the anchor can only be assumed if the following conditions of installation are met:

- Anchor installation carried out by appropriately qualified personnel under the supervision of the person responsible for technical matters on site.
- Use of the anchor only as supplied by the manufacturer.
- Anchor installation in accordance with the manufacturer's specifications and drawings.
- Checks before placing the anchor, to ensure that the characteristic values of the base material in which the anchor is to be placed, is identical with the values, which the characteristic loads apply.
- Check of the concrete being well compacted, e.g. without significant voids.
- Edge distances and spacings not less than the specified values without minus tolerances.
- Placing drill holes without damaging the reinforcement.
- In case of aborted hole: new drilling at a minimum distance away of twice the depth of the aborted hole or smaller distance if the aborted hole is filled with high strength mortar and if under shear or oblique tension load it is not the direction of the load application.
- Cleaning of the hole of drilling dust according to Annex 3.
- The drill hole may be filled with Injection mortar ATRION AVM-S.
- Anchor installation such that the embedment depth of the anchor in the concrete is not smaller than the value h_{nom} given in Annex 3, Table 2.
- Further turning of the anchor is not easy.
- The head of the anchor is fully supported on the fixture and is not damaged.
- The anchor may only be used once.

5 Responsibility of the manufacturer

The manufacturer is responsible to ensure that the information on the specific conditions according to 1 and 2 including Annexes referred to as well as sections 4.2 and 4.3 is given to those who are concerned. This information may be made by reproduction of the respective parts of the European technical approval. In addition, all installation data shall be shown clearly on the packaging and/or on an enclosed instruction sheet, preferably using illustrations.

The minimum data required are:

- Drill bit diameter,
- Size of the anchor,
- Maximum thickness of the fixture,
- Minimum embedment depth,
- Minimum hole depth,

European technical approval

ETA-07/0084

English translation prepared by DIBt

Page 8 of 14 | 31 October 2011

- Information on the installation procedure, including cleaning of the hole, preferably by means of an illustration,
 - Reference to any special installation equipment needed,
 - Identification of the manufacturing batch.
- All data shall be presented in a clear and explicit form.

Georg Feistel
Head of Department

beglaubigt:
Baderschneider

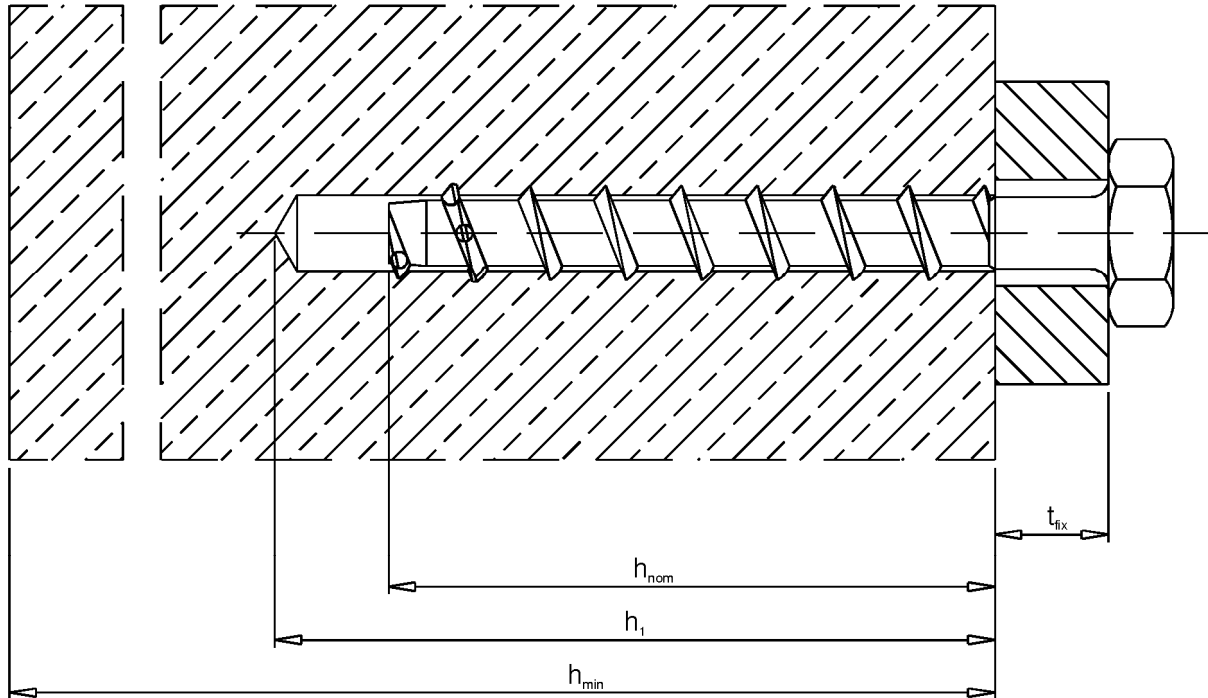
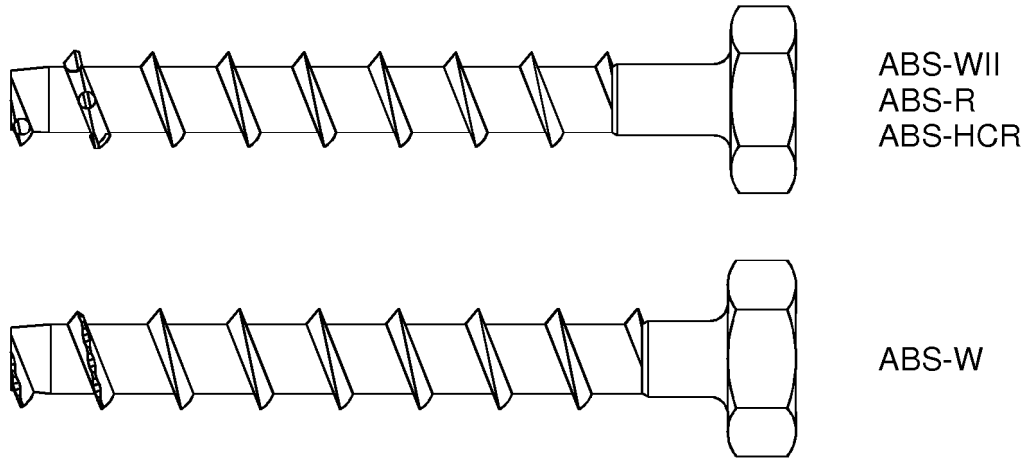

ATRION Concrete Screw ABS-W/-WII/-R and -HCR

Product and intended use

Annex 1

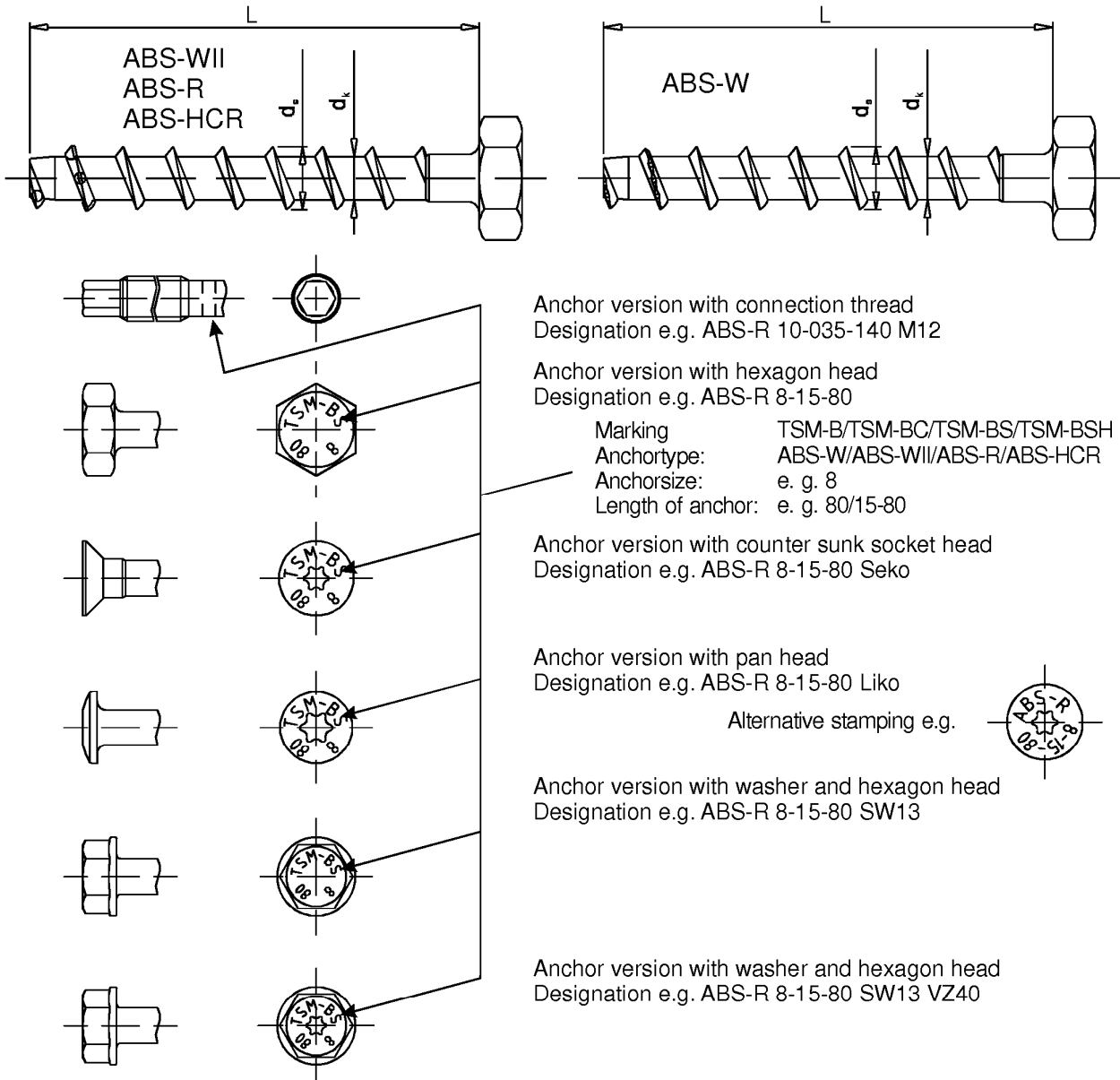

Anchor version with connection thread
Designation e.g. ABS-R 10-035-140 M12

Anchor version with hexagon head
Designation e.g. ABS-R 8-15-80
Marking TSM-B/TSM-BC/TSM-BS/TSM-BSH
Anchortype: ABS-W/ABS-WII/ABS-R/ABS-HCR
Anchor size: e.g. 8
Length of anchor: e.g. 80/15-80

Anchor version with counter sunk socket head
Designation e.g. ABS-R 8-15-80 Seko

Anchor version with pan head
Designation e.g. ABS-R 8-15-80 Liko
Alternative stamping e.g.

Anchor version with washer and hexagon head
Designation e.g. ABS-R 8-15-80 SW13

Anchor version with washer and hexagon head
Designation e.g. ABS-R 8-15-80 SW13 VZ40

Table 1: Dimensions and materials

Anchor size	ABS-W 8		ABS-W 10		ABS-W 12		ABS-W 14	
	ABS-WII 8		ABS-WII 10		ABS-WII 12		ABS-WII 14	
ABS-R 8		ABS-R 10		ABS-R 12		ABS-R 14		
ABS-HCR 8		ABS-HCR 10		ABS-HCR 12		ABS-HCR 14		
Length of Anchor	$L \geq$	[mm]	70	90	105	130		
	$L \leq$	[mm]	310	310	310	310		
Diameter of shaft	d_k	[mm]	6,8	8,8	10,8	12,8		
Diameter of thread	d_s	[mm]	10,6	12,6	14,6	16,6		
Material ABS-W and ABS-WII	Steel EN 10263-4, galvanized acc. to EN ISO 4042 or zinc flake coating acc. to EN ISO 10683 ($\geq 5\mu\text{m}$)							
Material ABS-R	1.4401 or 1.4404 or 1.4571 or 1.4578							
Material ABS-HCR	1.4529							

ATRION Concrete Screw ABS-W/-WII/-R and -HCR

Head versions:
Dimensions and materials

Annex 2

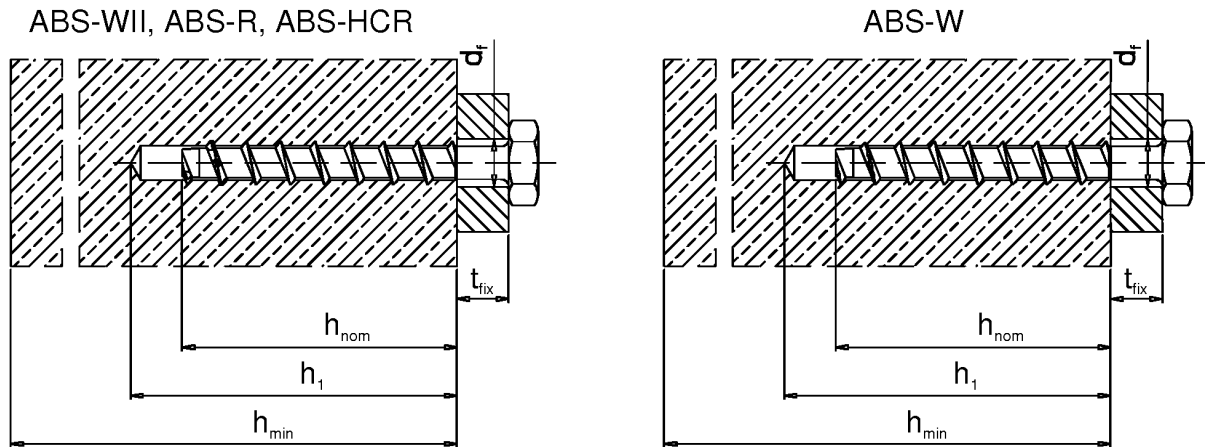

Table 2: Installation parameters

Anchor size			ABS-W 8	ABS-W 10	ABS-W 12	ABS-W 14
			ABS-WII 8	ABS-WII 10	ABS-WII 12	ABS-WII 14
			ABS-R 8	ABS-R 10	ABS-R 12	ABS-R 14
			ABS-HCR 8	ABS-HCR 10	ABS-HCR 12	ABS-HCR 14
Nominal drill bit diameter	d_o	[mm]	8	10	12	14
Cutting diameter of drill bit	$d_{cut} \leq$	[mm]	8,45	10,45	12,50	14,5
Depth of drill hole	$h_1 \geq$	[mm]	75	95	110	135
Embedment depth of anchor	$h_{nom} \geq$	[mm]	65	85	100	125
Diameter of clearance hole in the fixtur	$d_t \leq$	[mm]	12	14	16	18

Installation instruction

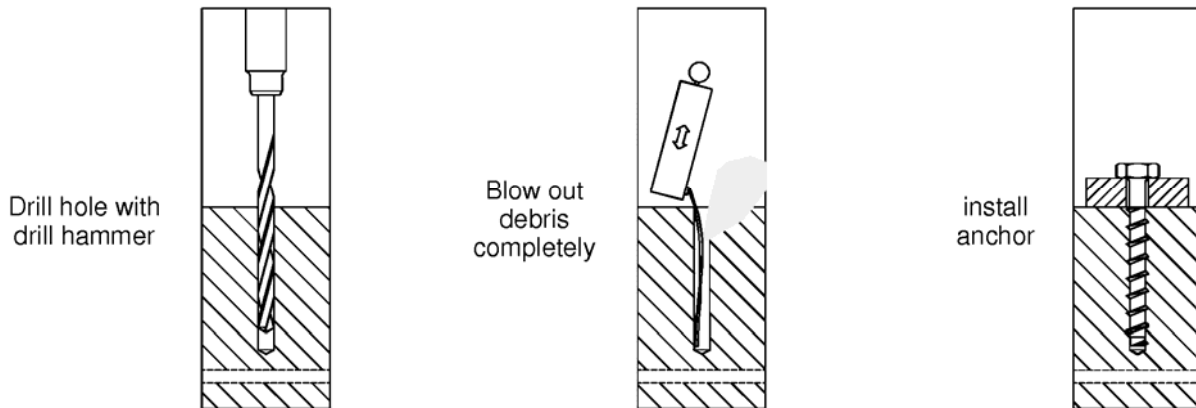

Table 3: Minimum thickness of concrete member, minimum spacing and minimum edge distance

Anchor size			ABS-W 8	ABS-W 10	ABS-W 12	ABS-WII 14
			ABS-WII 8	ABS-WII 10	ABS-WII 12	ABS-WII 14
			ABS-R 8	ABS-R 10	ABS-R 12	ABS-R 14
			ABS-HCR 8	ABS-HCR 10	ABS-HCR 12	ABS-HCR 14
Minimum thickness of member	h_{min}	[mm]	120	130	150	200
Minimum edge distance	c_{min}	[mm]	50	70	80	100
Minimum spacing	s_{min}	[mm]	50	70	80	100

ATRION Concrete Screw ABS-W/-WII/-R and -HCR

Installation parameters, installation instruction,
Minimum thickness of member and
Minimum spacing and edge distance

Annex 3

Table 4: Design method A
Characteristic values for tension load

Anchor Size ABS-			W 8	R 8	W 10	R 10	W 12	R 12	W 14	R 14	
			WII 8	HCR 8	WII 10	HCR 10	WII 12	HCR 12	WII 14	HCR 14	
Steel failure											
Characteristic resistance	$N_{RK,s}$	[kN]	25	29	42	48	64	73	90	103	
Partial safety factor	γ_{Ms} ¹⁾	-	1,4								
Pullout failure											
Characteristic resistance in cracked concrete C20/25	$N_{RK,p}$	[kN]	9	16		Pullout failure is not decisive					
Characteristic resistance in non-cracked concrete C20/25	$N_{RK,p}$	[kN]	12	Pullout failure is not decisive		Pullout failure is not decisive					
Increasing factors for cracked and non-cracked concrete	ψ_C	C30/37	1,22								
		C40/50	1,41								
		C50/60	1,55								
Partial safety factor	γ_{Mp} ¹⁾	-	1,5 ²⁾								
Concrete cone failure and splitting											
Effective anchorage depth	h_{ef}	[mm]	51	68	80	100					
Edge distance	$c_{cr,N} = c_{cr,sp}$	[mm]	1,5 h_{ef}								
Spacing	$s_{cr,N} = s_{cr,sp}$	[mm]	3 h_{ef}								
Partial safety factor	γ_{Mc} ¹⁾	-	1,5 ²⁾								

¹⁾ In absence of other national regulations

²⁾ The installation safety factor $\gamma_2=1,0$ is included

Table 5: Displacements under tension loads

Anchor Size ABS-			W 8	R 8	W 10	R 10	W 12	R 12	W 14	R 14	
			WII 8	HCR 8	WII 10	HCR 10	WII 12	HCR 12	WII 14	HCR 14	
Tension load	N	[kN]	4,3	7,6	11,1	15,9					
Displacement	δ_{No}	[mm]	0,5								
	$\delta_{N\infty}$	[mm]	1,0								

ATRION Concrete Screw ABS-W/-WII/-R and -HCR

Design method A
Characteristic values for tension loads,
Displacements

Annex 4

Table 6: Design method A
Characteristic values for shear load

Anchor Size ABS-			W 8	R 8	W 10	R 10	W 12	R 12	W 14	R 14
			WII 8	HCR 8	WII 10	HCR 10	WII 12	HCR 12	WII 14	HCR 14
Steel failure without lever arm										
Characteristic resistance	$V_{Rk,s}$	[kN]	18	21	34	40	42	49	64	
Partial safety factor	γ_{Ms} ¹⁾	-	1,50							
Steel failure with lever arm										
Characteristic resistance	$M_{Rk,s}^0$	[Nm]	26	29	56	64	123	141	200	229
Partial safety factor	γ_{Ms} ¹⁾	-	1,50							
Pryout failure										
Factor k in ETAG 001 Annex C equation (5.6)	k	-	1,0		2,0					
Concrete edge failure										
Effective length of anchor	l_f	[mm]	51		68		80		100	
Diameter of anchor	d_{nom}	[mm]	8		10		12		14	
Partial safety factor	γ_{Mc} ¹⁾	-	1,50 ²⁾							

¹⁾ In absence of other national regulations

²⁾ The installation safety factor $\gamma_2=1,0$ is included

Table 7: Displacements under shear loads

Anchor size ABS-			W 8	R 8	W 10	R 10	W 12	R 12	W 14	R 14
			WII 8	HCR 8	WII 10	HCR 10	WII 12	HCR 12	WII 14	HCR 14
Shear load	V	[kN]	8,6	10,0	16,2	19,1	20,0	23,3	30,5	
Displacement	δ_{V_0}	[mm]	2,7	2,9	2,7	3,5	4,0	4,1	3,1	4,6
	δ_{V_∞}	[mm]	4,1	4,4	4,3	5,3	6,0	6,2	4,7	7,0

Information for design of anchorage under shear load:

In general, the conditions given in ETAG 001 Annex C, section 4.2.2.1 a) and section 4.2.2.2 b) are not fulfilled because the diameter of clearance hole in the fixture according to Annex 3 Table 2 is greater than the values given in Annex C Table 4.1 for the corresponding diameter of the anchor.

ATRION Concrete Screw ABS-W/-WII/-R and -HCR

Design method A
Characteristic values for shear loads,
Displacements

Annex 5

Table 8: Characteristic values under fire exposure in concrete C20/25 to C50/60 for tension load

fire resistance class				W 8 WII 8	W 10 WII 10	W 12 WII 12	W 14 WII 14
R 30	Characteristic resistance	$N_{Rk,fi30}^0$ ²⁾	[kN]	2,3	4,0	6,3	9,8
R 60	Characteristic resistance	$N_{Rk,fi60}^0$ ²⁾	[kN]	1,7	3,3	5,8	8,1
R 90	Characteristic resistance	$N_{Rk,fi90}^0$ ²⁾	[kN]	1,1	2,2	4,2	5,9
R 120	Characteristic resistance	$N_{Rk,fi120}^0$ ²⁾	[kN]	0,8	1,7	3,4	4,8
R 30 to R 120	Spacing	$s_{cr,fi}$	[mm]	4 h _{ef}			
		s_{min}	[mm]	50	70	80	100
	Edge distance ¹⁾	$c_{cr,fi}$	[mm]	2 h _{ef}			
		c_{min}	[mm]	2 h _{ef}			

¹⁾ In case of fire attack from more than one side, the edge distance shall be ≥ 300 mm

²⁾ In absence of other national regulations the partial safety factor for resistance under fire exposure $\gamma_{M,fi} = 1,0$ is recommended.

Table 9: Characteristic values under fire exposure in concrete C20/25 to C50/60 for tension load

fire resistance class				R 8 HCR 8	R 10 HCR 10	R 12 HCR 12	R 14 HCR 14		
R 30	Characteristic resistance	$N_{Rk,fi30}^0$ ²⁾	[kN]	2,3 ⁴⁾	2,3 ³⁾	4,0 ⁴⁾	4,0 ³⁾	6,3	9,8
R 60	Characteristic resistance	$N_{Rk,fi60}^0$ ²⁾	[kN]	1,7 ⁴⁾	2,3 ³⁾	3,3 ⁴⁾	4,0 ³⁾	5,8	8,1
R 90	Characteristic resistance	$N_{Rk,fi90}^0$ ²⁾	[kN]	1,1 ⁴⁾	2,3 ³⁾	2,2 ⁴⁾	4,0 ³⁾	4,2	5,9
R 120	Characteristic resistance	$N_{Rk,fi120}^0$ ²⁾	[kN]	0,8 ⁴⁾	1,8 ³⁾	1,7 ⁴⁾	3,2 ³⁾	3,4	4,8
R 30 to R 120	Spacing	$s_{cr,fi}$	[mm]	4 h _{ef}					
		s_{min}	[mm]	50	70	80	100		
	Edge distance ¹⁾	$c_{cr,fi}$	[mm]	2 h _{ef}					
		c_{min}	[mm]	2 h _{ef}					

¹⁾ In case of fire attack from more than one side, the edge distance shall be ≥ 300 mm

²⁾ In absence of other national regulations the partial safety factor for resistance under fire exposure $\gamma_{M,fi} = 1,0$ is recommended.

³⁾ for anchor version with hexagon head and with counter sunk socket head

⁴⁾ for anchor version with connection thread

ATRION Concrete Screw ABS-W/-WII/-R and -HCR

Characteristic values under fire exposure

Annex 6