



European Technical Approval ETA-09/0087

English translation prepared by DIBt - Original version in German language

Handelsbezeichnung
Trade name

B+F Fahrzeug-Tragwannen
B+F Motor Vehicle Load-Bearing Elements

Zulassungsinhaber
Holder of approval

B+F Beton- und Fertigteilegesellschaft mbH
Lauchhammer
Bockwitzer Straße 85
01979 Lauchhammer
DEUTSCHLAND

Zulassungsgegenstand
und Verwendungszweck
*Generic type and use
of construction product*

B+F Fahrzeug-Tragwannen zur Verwendung in LAU-Anlagen
*B+F Motor Vehicle Load-Bearing Elements to use for the storage, filling
and handling of liquid substances (substances hazardous to water)*

Geltungsdauer:
Validity: vom
from
bis
to

11 August 2011
18 May 2014

Herstellwerk
Manufacturing plant

B+F Beton- und Fertigteilegesellschaft mbH
Lauchhammer
Bockwitzer Straße 85
01979 Lauchhammer
DEUTSCHLAND

Diese Zulassung umfasst
This Approval contains

24 Seiten einschließlich 10 Anhänge
24 pages including 10 annexes

Diese Zulassung ersetzt
This Approval replaces

ETA-09/0087 mit Geltungsdauer vom 18.05.2009 bis 18.05.2014
ETA-09/0087 with validity from 18.05.2009 to 18.05.2014

I LEGAL BASES AND GENERAL CONDITIONS

- 1 This European technical approval is issued by Deutsches Institut für Bautechnik in accordance with:
 - Council Directive 89/106/EEC of 21 December 1988 on the approximation of laws, regulations and administrative provisions of Member States relating to construction products¹, modified by Council Directive 93/68/EEC² and Regulation (EC) N° 1882/2003 of the European Parliament and of the Council³;
 - Gesetz über das In-Verkehr-Bringen von und den freien Warenverkehr mit Bauprodukten zur Umsetzung der Richtlinie 89/106/EWG des Rates vom 21. Dezember 1988 zur Angleichung der Rechts- und Verwaltungsvorschriften der Mitgliedstaaten über Bauprodukte und anderer Rechtsakte der Europäischen Gemeinschaften (Bauproduktengesetz - BauPG) vom 28. April 1998⁴, as amended by law of 31 October 2006⁵;
 - Common Procedural Rules for Requesting, Preparing and the Granting of European technical approvals set out in the Annex to Commission Decision 94/23/EC⁶.
- 2 Deutsches Institut für Bautechnik is authorized to check whether the provisions of this European technical approval are met. Checking may take place in the manufacturing plant. Nevertheless, the responsibility for the conformity of the products to the European technical approval and for their fitness for the intended use remains with the holder of the European technical approval.
- 3 This European technical approval is not to be transferred to manufacturers or agents of manufacturers other than those indicated on page 1, or manufacturing plants other than those indicated on page 1 of this European technical approval.
- 4 This European technical approval may be withdrawn by Deutsches Institut für Bautechnik, in particular pursuant to information by the Commission according to Article 5(1) of Council Directive 89/106/EEC.
- 5 Reproduction of this European technical approval including transmission by electronic means shall be in full. However, partial reproduction can be made with the written consent of Deutsches Institut für Bautechnik. In this case partial reproduction has to be designated as such. Texts and drawings of advertising brochures shall not contradict or misuse the European technical approval.
- 6 The European technical approval is issued by the approval body in its official language. This version corresponds fully to the version circulated within EOTA. Translations into other languages have to be designated as such.

¹ Official Journal of the European Communities L 40, 11 February 1989, p. 12
² Official Journal of the European Communities L 220, 30 August 1993, p. 1
³ Official Journal of the European Union L 284, 31 October 2003, p. 25
⁴ *Bundesgesetzblatt Teil I 1998*, p. 812
⁵ *Bundesgesetzblatt Teil I 2006*, p. 2407, 2416
⁶ Official Journal of the European Communities L 17, 20 January 1994, p. 34

II SPECIFIC CONDITIONS OF THE EUROPEAN TECHNICAL APPROVAL

1 Definition of the product and intended use

1.1 Definition of the construction product

- (1) The "B+F Motor Vehicle Load Bearing Elements" (in the following called "pre-fabricated elements") are pre-fabricated elements made of reinforced concrete used in facilities for the storage, filling and handling of liquid chemicals (substances hazardous to water).
- (2) They are manufactured with and/or without surface protection systems in the following variations (see annex 2):
 - Type LR, Type IR, Type IR-KH,
 - Type QR, Type TR and Type ME
- (3) The dewatering and/or drainage occur by means of the slope drain.
- (4) They are composed of reinforced concrete of a determined composition (recipe) taking into account EN 206-1, which additionally has the performance capacities of a liquid-tight concrete.
- (5) They are weather-resistant and, in case of frost, insensitive to freeze-thaw cycle.
- (6) The pre-fabricated elements could have a mean crack width of $\leq 0,1$ mm .
- (7) In case of all-over bearing of the pre-fabricated elements on a determined load-spreading basis, they shall be accessible and trafficable by motor vehicles.
- (8) The pre-fabricated elements satisfy in regard to the reaction-to-fire performance the class "A1" according to EN 13501-1. If using surface protection systems the chosen surface protection system has to satisfy in regard to reaction to fire at least with the requirements of normal flammable construction products, e.g. class E, according to EN 13501-1.

1.2 Intended use

- (1) The pre-fabricated elements with and/or without surface protection systems may be used in facilities for the storage, filling and handling of liquid chemicals (substances hazardous to water). They can be used both inside the buildings and outdoors over a specified period of time and/or frequency in case of against
 - time limited effects in the event of accident (storage) and/or
 - intermittent stress (filling and handling)
 of liquid chemicals (substances hazardous to water). In the course of which are exposed to combinations of simultaneous and/or successive effects (e.g. chemicals, temperature, weather, traffic).
- (2) The use of the pre-fabricated elements without coating systems in sealing constructions is restricted to the fields of application where under mechanical action due to load and restraint
 - the least thickness of the un-cracked pre-fabricated elements in the field range is bigger than γ_e -times of the characteristic penetration depth and
 - on the edge of the element of the un-cracked pre-fabricated elements the area of the protected joint sidewall " d_H " exceeds the characteristic penetration depth of the liquid chemicals (substances hazardous to water).

The characteristic penetration depth " e_{tk} " is determined to $e_{tk} = e_{tm} \cdot \gamma_s$

(3) The pre-fabricated elements shall be used both separately and lined up. The connection of the pre-fabricated elements shall occur by means of suitable impermeable to liquid joint sealing systems only that are approved for the respective intended use (e.g. in accordance with national or European technical approvals).

(4) The pre-fabricated elements shall be used by a permanently changed mechanical stress in facilities, which are at the same time also intended for traffic by motor vehicles.

(5) The provisions referred to in this European technical approval have been written based upon the assumed working life of the pre-fabricated elements of at least 25 years, provided that the conditions for the transport/ storage/ installation/ use/ servicing/ correction of the defect/ utilization are met. The indications given on the working life cannot be interpreted as a guarantee given by the ETA holder, but are regarded only as a means for choosing the right products in relation to the expected economically reasonable working life of the works.

2 Characteristics of product and methods of verification

2.1 General

(1) The pre-fabricated elements of the sealing construction shall correspond to the drawings and indications given in the Annexes.

(2) The characteristics of the material, the dimensions and tolerances which are not declared in this approval correspond to the information laid down in the technical documentation⁷ of this European technical approval.

(3) Requirements upon the pre-fabricated elements from other ranges of law will remain unaffected.

2.2 Properties

(1) The pre-fabricated elements have the following properties:

- They are resistant to weather and, in case of frost during high water saturation with thaw agent insensitive to freeze-thaw cycle.
- The pre-fabricated elements satisfy the requirements of the exposure classes XC4, XD3, XF4 and XM2 according to EN 206-1:2001-07.

(2) pre-fabricated elements without surface protection are

- impermeable to liquids. The penetration behaviour of liquid chemicals (substances hazardous to water) in the pre-fabricated elements correspond the penetration behaviour curve according to Annex 3, Figure 1.
- accessible by pedestrians and in case of all-over bearing of the pre-fabricated elements on a load-spreading basis trafficable by motor vehicles with pneumatic tyres according to Annex 4, Table 1,
- classified in the wear classes according to Annex 4, Table 1.

(3) The pre-fabricated elements are used with the following surface protections (Annex 3, Table 1):

- trafficable coating systems and/or
- coating systems and/or plastics sheets for the lining covered with trafficable ceramic plates and

in accordance with the requirements of the respective Member States for the intended use in facilities for the storage, filling and handling of liquid chemicals (substances hazardous to water), e.g. in G.: according to national approvals and/or construction products list A Part 1, No. 15.31.

(4) According to the requirements of the respective Member States the surface protections are

⁷ The technical documentation of this European technical approval is deposited with Deutsches Institut für Bautechnik and shall be made available to the approved bodies, who are involved in the procedure of conformity attestation, for the fulfilment of their tasks.

- liquid tight and resistant against defined liquid chemicals (substances hazardous to water) if the used surface protections are approved for this intended use in facilities for the storage, filling and handling of liquid chemicals (substances hazardous to water)
- resistant to weather
- accessible by pedestrians and trafficable by motor vehicles with different wheel material, if the used surface protection is approved for this intended use, see Annex 4, Table 1.

2.3 Formulation

(1) For the pre-fabricated elements the concrete is used according to the composition (recipe) deposited, which has the performance capacities of a liquid-tight concrete after penetration test. The safety factor γ_s for determining the characteristic penetration depth e_{tk} and the safety factor γ_e for determining minimum thickness of construction element shall be considered according to Annex 10. The concrete composition (recipe) for the pre-fabricated elements is deposited with DIBt.

(2) The concrete for the pre-fabricated elements, cement, aggregates, concrete admixture and reinforcement of the pre-fabricated elements shall comply with the deposited information and requirements given in Annex 4, Table 1.

(3) As transport and mounting fixings the DEHA-Transport-Anchors are used dependent on the relevant load case.

(4) The delivery pipes for the draining have to meet the requirements of Annex 3, Table 1 and Annex 9.

2.4 Emission of dangerous substances

(1) According to the applicant's declaration the pre-fabricated elements taking account of the EU⁸ database do not contain any dangerous substances.

(2) In addition to the specific clauses relating to dangerous substances contained in this European technical approval, there may be other requirements applicable to the products falling within its scope (e.g. transposed European legislation and national laws, regulations and administrative provisions). In order to meet the provisions of the Construction Products Directive these requirements need also, if applicable, to be complied with.

(3) There may be other requirements applicable to the products resulting from other applicable national regulations and administrative provisions. These requirements need also to be complied with.

3 Evaluation and attestation of conformity and CE marking

3.1 System of attestation of conformity

(1) According to the Decision 1999/94/CE of the European Commission, the System 2+ of attestation of conformity is to be used.

(2) Additionally according to the Decision 2001/596/EC of the European Commission⁹ the System 4 of attestation of conformity is to be used in relation to the reaction-to-fire performance. These systems of attestation of conformity are described in the following:

System 2+: Declaration of conformity of the product by the manufacturer on the basis of:

(a) Tasks for the manufacturer:

- (1) initial type-testing of the product;
- (2) factory production control;
- (3) testing of samples taken at the factory in accordance with a prescribed test plan.

⁸ References in Guidance Paper H: A harmonised approach with regard to the handling of dangerous substances according to the Construction Products Directive, Brussels 18 February 2000.

⁹ Official Journal of the European Communities L 209/33 of 2.8.2001.

- (b) Tasks for the notified body:
- (4) certification of factory production control on the basis of:
- initial inspection of factory and of factory production control;
 - continuous surveillance, assessment and approval of factory production control.

System 4: Declaration of conformity of the product by the manufacturer on the basis of:

Tasks for the manufacturer:

- (1) initial type-testing of the product;
- (2) factory production control;

Note: approved body are also named "notified body"

3.2 Responsibilities

3.2.1 Tasks of the manufacturer

3.2.1.1 Factory production control

(1) The manufacturer shall exercise permanent internal control of production. All the elements, requirements and provisions adopted by the manufacturer shall be documented in a systematic manner in the form of written policies and procedures, including records of results performed. The factory production control shall ensure that the product conforms with this European technical approval.

(2) The manufacturer may only use initial and constituent materials stated in the technical documentation of this European technical approval. He shall inspect or control the initial materials within the incoming goods inspection according to the control plan.

(3) The factory production control must be in accordance with the control plan of May 2009 relating to the European technical approval ETA-09/0087 issued on 11.08.2011 this is part of the technical documentation of this European technical approval. The control plan is laid down in the context of the factory production control system operated by the manufacturer and deposited with Deutsches Institut für Bautechnik.¹⁰ The factory production control follows the properties given in the control plan. They are specified in the technical documentation. For the test of penetration behaviour according to the control plan ethanol shall be used as reference testing liquid.

(4) The results of factory production control shall be recorded and evaluated in accordance with the provisions of the control plan. The records shall include at least the following information:

- Designation of the product, of the initial materials,
- type of inspection or test,
- date of the manufacture of the product, batch N° (if relevant) and date of the inspection or test of the product / the initial materials
- results of the inspections or tests and, if applicable, comparison with the requirements
- signature of the person responsible for the factory production control.

(5) The records shall be kept for a minimum of five years. On request they shall be presented to Deutsches Institut für Bautechnik.

(6) Details concerning extent, type and frequency of the tests or inspections to be performed within the scope of the factory production control shall correspond to the control plan which is part of the technical documentation to this ETA.

¹⁰ The "control plan" is a confidential part of the European technical approval and only handed over to the approved bodies involved in the procedure of attestation of conformity. See section 3.2.2.

3.2.1.2 Other tasks for the manufacturer

(1) The manufacturer shall, on the basis of a contract, involve a body which is approved for the tasks referred to in section 3.1 in the field of pre-fabricated elements in order to undertake the actions laid down in section 3.2.2. For this purpose, the "control plan" referred to in sections 3.2.1.1 and 3.2.2 shall be handed over by the manufacturer to the approved body involved.

(2) The manufacturer shall make a declaration of conformity, stating that the construction product is in conformity with the provisions of the European technical approval ETA-09/0087 issued on 18.05.2009.

3.2.2 Tasks for the approved bodies

(1) The approved body shall perform the following tasks in accordance with the provisions of the "control plan":

- initial inspection of factory and of factory production control,
- continuous surveillance, assessment and approval of factory production control.

(2) The approved body shall retain the essential points of its actions referred to above and state the results obtained and conclusions drawn in a written report.

(3) The approved certification body involved by the manufacturer shall issue an EC certificate of conformity of the factory production control stating the conformity with the provisions of this European technical approval.

(4) The verifications, on which the ETA is based, were furnished by samples taken from the current production, thus only a reduced initial type-testing according to the specifications in the control plan¹¹ shall be performed.

(5) In cases where the provisions of the European technical approval and its control plan are no longer fulfilled the certification body shall withdraw the certificate of conformity and inform Deutsches Institut für Bautechnik without delay.

3.3 CE marking

The CE marking shall be affixed on the delivery. The letters "CE" shall be followed by the identification number of the approved certification body and be accompanied by the following additional information:

- the name and address of the producer (legal entity responsible for the manufacturer),
- the last two digits of the year in which the CE marking was affixed,
- the number of the EC certificate for the factory production control,
- number of the European technical approval
- reaction to fire
- essential properties:
 - details of the crack class
 - details of the level of trafficability relating to the loading contact area and trafficable intensity.
 - The resistance to various media shall be defined in terms "*Penetration behaviour of liquids in accordance with annex 2 of the ETA*".

4 Assumptions under which the fitness of the product for the intended use was favourably assessed

4.1 Manufacturing

(1) The pre-fabricated elements including all built-in units as well as surface protections and transport and mounting fixings are manufactured at the factory "B+F Beton- und Fertigteilegesellschaft mbH Lauchhammer, Bockwitzer Straße 85, 01979 Lauchhammer, Germany".

(2) The European technical approval is issued for the product on the basis of agreed information, deposited with Deutsches Institut für Bautechnik, which identifies the product that has been assessed and judged.

(3) Changes to the product or production process, which could result in this deposited information being incorrect, should be notified to Deutsches Institut für Bautechnik before the changes are introduced. Deutsches Institut für Bautechnik will decide whether or not such changes affect the approval and consequently the validity of the CE marking on the basis of the approval and if so whether further assessment or alterations to the approval shall be necessary.

(4) The application of the surface protections shall only happen at the factory mentioned above in accordance with the provisions of the respective verification of applicability (e.g. national or european approval)

4.2 Installation

4.2.1 Conditions for the installation

(1) A sealing construction with pre-fabricated elements shall be carried out by expert designers only. The controllable design drawings and/or positioning plans for the installation of the pre-fabricated elements shall be made by an expert designer taking account of the requirements at national level of the respective countries for this field of application and the expected installation conditions.

(2) The design of a facility (SFH-facilities) for the storage, filling and handling of liquid chemicals (substances hazardous to water) shall take into account that this approval does not regulate the altogether necessary retaining volume, not the further facility parts necessary for ensuring this volume (e.g. storage space, pipe systems).

(3) Furthermore the requirements for the drainage and the control of atmospheric water applicable to the installation have to be considered.

(4) The drainage surface shall be designed in such a way that in case of the precipitation attack and of the liquid chemicals (substances hazardous to water) at the same time, the whole amount of liquid will be conducted backflow-free.

(5) The requirements from other ranges of law (occupational safety law, hazardous substances legislation) will remain unaffected.

(6) For the closure of joints between the pre-fabricated elements and to other protection surfaces the joint sealing systems are appropriate with European technical approval and/or national approval according to requirements at national level of the respective countries for this field of application that

- are tight and resistant to the liquids which penetration behaviour can be evaluated positive according to Annex 2
- ensure an allowed extension and/or compression deflection according to the respective approval of the joint sealing system,
- ensure an allowed shear strain of $\leq 3,0$ mm in the field of cross- or T-intersections,
- allow a required joint width according to Annex 4 and
- if using surface protections it is permitted to connect the joint sealing system with them.

(7) Joint sealing's shall be designed in such a way that the interaction between the selected joint sealing system on the pre fabricated element will be considered, see the mounting and installation instruction of the manufacturer. Thereby, the protected joint sidewall d_H according to Annex 5 is decisive.

(8) The installation of the pre-fabricated elements shall be designed on the load-bearing basis according to the provisions of this European technical approval (see Annex 5) and the applicant's installation instruction. The flawless nature of the foundation as well as the permissibility of the foundation loads occurring shall be tested and verified separately. In case of foundations with unfavourable or strongly varying deformation behaviour, the corrections of the foundation have to be designed beforehand.

(9) The pre-fabricated elements are designed sufficient for the applications according to section 1. The design calculation has been done according to EN 1992-1-1 (EC 2) taking into account the levels of trafficability according to Annex 4 and the safety factors according to Annex 10. All elements have met the levels of trafficability from t 0 to t 3. This shall only apply, provided that the basis satisfies provisions of the section 4.2.3 as well as Annex 4.

4.2.2 Processing

(1) The installation of pre-fabricated elements is carried out by firms according to section 4.2.5 only.

(2) For the proper installation of the pre-fabricated elements the holder of approval shall draw up an installation and assembling instruction.

(3) The conditions of installation given in the approval, the rail specific regulations and by the applicant have to be respected.

(4) The installation and/or application of the respective joint sealing systems and/or surface protection systems shall be only carried out in accordance with the respective European technical or national approval and/or provisions of the respective Member States.

(5) The installer shall hand over to the user of the installation a copy of this approval as well as installation and assembling instructions of the applicant.

4.2.3 Basis

Before laying the pre-fabricated elements the suitability of the basis shall be determined according to the provisions of the sections 4.2.1(8). It shall not exceed the allowed values of the annex 4 and shall not differ from provisions given in the installation and assembling instructions. The modulus of deformation " E_s " shall be confirmed by means of the plate-bearing test.

4.2.4 Installation of pre-fabricated elements

(1) The pre-fabricated elements shall be with all integrated installations and prepared joints. Single elements may not be replaced.

(2) The connection to other sealing constructions shall occur in accordance with installation and assembling instructions of the ETA holder.

(3) The connection to other pre-fabricated elements shall occur in accordance with section 4.2.1.

(4) Damaged pre-fabricated elements (e.g. with cracks wider than 0,1 mm) may not be installed.

(5) The permissible joint width according to Annex 4 and/or 5 shall be guaranteed, especially, if joint sealing compound systems shall be used, e.g. by gauge or distance piece.

4.2.5 Installing firm

(1) The installation of pre-fabricated elements is carried out by firms only who (including their specialists) are authorised and trained by the approval holder. Further requirements for the installing firm can result from national provisions of the Member States, e.g. in G.: obligation of a qualified firm (*Fachbetriebspflicht*).

(2) The confirmation of the conformity of the installed sealing construction with this approval shall be given with a declaration by the installing firm on basis of the following controls:

- Control, whether the right pre-fabricated elements are used for the installation according to technical rules of the sealing construction as well as the marking according to section 3.3.
- Control, that between the pre-fabricated elements only joint sealing systems with national and /or European approval are installed, which meet the criteria of the sections 1.2(3) and 4.2.
- Control, that for the protection of the surface of the pre-fabricated elements are only systems used with national or European approval and/or in accordance with the provisions of the respective Member States, which meet the criteria of the sections 1.2 (2) and 4.2.
- Control of the installation according to section 4.2.6.

(3) The results of controls shall be recorded and evaluated. The records shall include at least the following information:

- Sealing construction: " B+F Motor vehicle load-bearing elements to use in SFH-facilities"
- Approval number: ETA-09/0087
- Approval holder: *Name, Address*
- Installation on: *Date*
- Installing firm: *Name, Address*
- Kind of control or test (see section 4.2.6)
- Day of the test
- Results of the control and tests and comparison with the requirements
- Provisions to which the sealing construction conforms:
 - reaction-to-fire class (elements / joint sealing / surface protection),
 - admissible levels of road serviceability (elements / joint sealing) and, if necessary, the suitability of the trafficability of the surface protection
 - resistance to media of the pre-fabricated elements shall be given with the wording "*Resistance to media in accordance with Annex 2 of the ETA-09/0087*".
 - resistance to media of the installed joint sealing system shall be given with the wording "*Resistance to media in accordance with Annex 2 of the ETA-xx/yyy and/or national approval Nr.: xyz*".
 - resistance to media of the installed surface protection shall be given with the wording
 - "*Resistance to media in accordance with ETA-xx/yyy / national approval Nr.: xyz*" and/or
 - In accordance with the provisions of the respective Member States, e.g. in G.: "*according to construction products lists A, part A (Bauregelliste A), No. xy*".
- Particular conditions applicable to the use of the product

"Repair work /retrofitting is only permitted with retrofit systems and or -products, which are approved for the respective intended use (in accordance with national and/or European technical approvals), see section 1.2. Beyond that the respective instructions of the manufacturer have to be taken into account."
- Name of, and position held by, the person empowered to sign the declaration on behalf of the installing firm or of his authorized representative.

(4) The documentation and the declaration of the installing firm shall be given to the construction file of the respective object. On request they shall be presented to the approval body, the relevant construction supervision authority and the expert personnel in accordance with the national regulations of the Member States.

(5) If there are insufficient test results the installing firm shall immediately take the necessary actions to stop the defect. After having stopped the defects the test to be passed which is necessary to verify that the defect has been eliminated shall be repeated immediately, if technically possible.

4.2.6 Control of the execution

- (1) The basis set-up must comply with representations of Annex 5.
- (2) The sufficient compaction of the basis (E_s -value according to Annex 5) shall be verified before laying the pre-fabricated elements (once every pre-fabricated element and/or once every 50 m if the pre-fabricated elements are connected installed).
- (3) The control of the surface protection is carried out according to the respective national approval for the intended use in SFH-facilities and/or accordance with the provisions of the respective Member States.
- (4) During the laying of the pre-fabricated elements, records on the verification of the proper installation shall be kept by construction supervisor or agents of supervisor.
- (5) The records shall be at the disposal during the construction period on the construction site and on request shall be handed over to the construction supervision agent. They shall also be kept as the delivery note after works by the company for a minimum of five years such.

4.3 Responsibilities for the ETA holder

It is the responsibility of the holder of approval to make sure that all those who use his pre-fabricated elements will be appropriately informed about the specific conditions according to sections 1, 2, 4, and 5 including the annex to this ETA, the installation and processing instructions by the holder of approval and the not confidential part of the technical documentation to this ETA.

This information can be given by reproduction of the corresponding parts of the European technical approval.

5 Indications to the holder of approval

5.1 Transport and storage

5.1.1 Transport

- (1) The pre-fabricated elements are provided for transportation/delivering with all inlets, prepared joints.
- (2) The transportation to the installation point occurs with an appropriate transport vehicle.

5.1.2 Storage

The storage and/or intermediate storage of the pre-fabricated elements on load-spreading frost-free basis shall be so that no inadmissible exposures can occur.

5.2 Use, servicing, correction of the defect

(1) In order to ensure the fitness for use of the pre-fabricated elements and/or the sealing construction manufactured of these pre-fabricated elements, the measures described in sections (2) to (6) are recommended. It is the task of the ETA holder to make sure that all parties involved are adequately informed.

(2) The operator of the respective facility establishes operating instructions including the description of the necessary measures

- for the control of the proper condition
- for ensuring proper operation
- for maintenance and cleaning

of the sealing construction as well as the description of measures to be taken in case of damage. The inspection intervals are specified according to the stress levels given in Annex 4 in conjunction with Annex 10 of this ETA. The inspection results are documented.

(3) Dripping losses and/or accumulations of already minor liquid quantities are directly removed.

(4) Leaked out substances hazardous to water will immediately be bound with suitable means. The polluted bonding agent is taken up and recycled duly and without loss or is disposed of. Appropriate materials and/or employment devices are specified in the operating instructions and are constantly ready in sufficient quantity. For the disposal and treatment, respectively, of the materials resulting in waste reference is made to the applicable regulations of the respective Member State (e.g. in G: Abfallgesetz ('Waste management law')).

(5) The operator charges only those factories with maintenance, repair work and cleaning of the sealing construction, which for this purpose dispose of personnel authorised and instructed for this field of application according to the requirements of the respective countries.

(6) After each repair work of a larger extent a start-up check will be carried out according to section 5.2(8) and/or the recurring test according to section 5.2(9) shall be repeated by the person charged with the test.

(7) Before the operation of a facility and, if necessary, after required correction of the defect, the start-up inspections are carried out as follows:

- The start-up inspection is carried out by expert personnel only. Further requirements for the individuals can result from national regulations of the Member States.
- The person put in charge of the inspection will constantly be kept informed on the process of the work. The person is given the possibility to participate in the controls of the pre-fabricated elements before and after the installation according to section 4.2.6 and to evaluate the results of the controls.
- Checking the condition of the installed pre-fabricated elements is done via visual inspection of the sealing construction.
- Checking of the installed joint sealing system and/or surface protection system is done according to the provisions of the relevant European technical approval or the national approval and/or according to the requirements of the respective Member States for this field of application.
- The person put in charge of the inspection examines the intended control intervals of the operating instructions by the operator of the respective installation (see section 5.2(2)).

(8) One year after every start-up inspection and then every five years recurring inspections shall be performed as follows.

- The recurring inspections are carried out by expert individuals. Further requirements for the individuals can result from national regulations of the Member State.
- The investigation of the condition of the sealing construction is done via visual check of all areas of the respective sealing construction. The pre-fabricated elements are considered furthermore as tight and trafficable within the meaning of this approval, if no mechanical damage of the surface and/or no visible conversion procedure on the surface are identifiable and if cracks, not wider than 0,1 mm are identified.
- In addition the examination for protection effect of the joint sealing system and, if relevant, of the surface protection shall be carried out according to the provisions of the relevant European technical approval or the national approval and/or according to the requirements of the respective countries for this field of application.
- On the basis of the documentation in accordance with section 5.2(2) it is checked whether
 - the check intervals were kept,
 - the specifications of the operating instructions are observed, and
 - no longer contact has occurred between the pre-fabricated elements and the liquids hazardous to water in the course of use.

- If doubts arise about the tightness of the sealing construction (e.g. due to bigger cracks) further examinations become necessary. For that purpose samples (drilling core) will be taken from the section concerned, if need be. It can be done without the taking of samples from the soil underneath the pre-fabricated element, if demonstrably no complete penetration of the sealing construction occurred by liquids hazardous to water.
- (9) If during the start-up inspection the defects have been determined, they are to be repaired immediately, taking account of the following provisions. A firm according to section 4.2.2 is charged with repair damage that may use materials indicated in this notification in accordance with indications of the processing instructions by the applicant.
- The damaged pre-fabricated elements of the sealing construction (e.g. cracks wider than 0,1 mm, scalings and/or excavations) shall be exchanged. The replacement of the damaged pre-fabricated element is carried out in accordance with the provisions of this approval, taking into account the provisions of the relevant approval for the joint sealing system for facilities for the storage, filling and handling of liquid chemicals (substances hazardous to water).
 - Damaged area and/or parts of the joint sealing system or the surface protection shall be corrected taking into account the provisions of the relevant verification of applicability of the joint sealing and/or surface protection system.
 - If a correction of the defect is necessary, the testing shall be repeated in either case by an expert person according to section 5.2(8), first dash.
- (10) Further national regulations of the Member States shall remain unaffected.

6 Recommendations for the operator of a facility for the storage, decanting and handling of liquid chemicals (substances hazardous to water)

- (1) Reference is made to the necessity of a permanent surveillance by the operator of the installation for tightness and operability of the sealing construction in accordance with the requirements of the national regulations of the respective Member States.
- (2) An operating instruction is prepared by the operator of the respective installation which takes the following points into account:
- The contents of the regulations to be applied by the employee working in these fields will be presented in the operating instructions in a comprehensible and clear way and be laid out or put up at a suitable place of the plant. The operating instruction can be part of operating instructions in accordance with other fields of law of the respective Member States.
 - The employees working in these fields will be instructed in the possible threats to water when storing, filling and handling substances hazardous to water as well as in the measures of hazard control. Before working in this field, they will be instructed before working with these substances and afterwards at least once per year.
 - All essential measures of control by the operator, the maintenance and the cleaning will be specified in the operating instructions. The realization of the measures will be noted in each case in the company journal.
 - In this operating instruction the operator lays down his inspection intervals in accordance with Annex 4 in conjunction with Annex 10. These records are ready and will be presented to the person responsible according to the national regulations in force of the respective country.
- (3) The operator of a facility for the storage, filling and handling of liquid chemicals (substances hazardous to water) commissions only enterprises with maintenance and cleaning of the sealing construction according to section 4.2.2(1).

European technical approval

ETA-09/0087

English translation prepared by DIBt

Page 14 of 24 | 11 August 2011

(4) If after the start-up check a correction of the defect is necessary, the start-up check shall be repeated in either case according to section 5.2(8), taking into account the applicable national regulations of the respective country.

(5) The sealing construction is driven on only with vehicles according to the provisions referred to Annex 4, Table 1.

Uwe Bender
Head of Department

beglaubigt:
Kluge

B+F Motor Vehicle Load-Bearing Elements

- made of liquid-tight reinforced concrete or
 - made of reinforced concrete, additionally protected with suitable surface protections
- used in SFH- facilities**

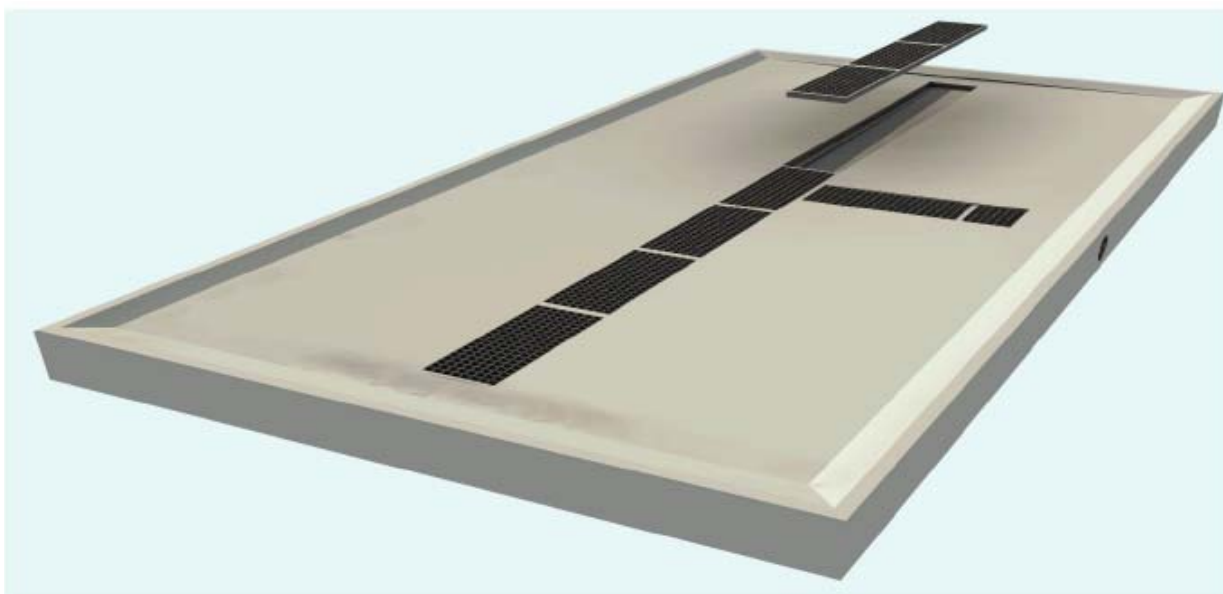

Trafficable by motor vehicles and accessible by pedestrians

SFH- facilities: Facilities for the storage, filling and handling of liquid chemicals (substances hazardous to water)

B+F Motor Vehicle Load-Bearing Elements

Motor vehicle load bearing elements, example

Annex 1

Motor vehicle load bearing elements, examples of element types

Type IR

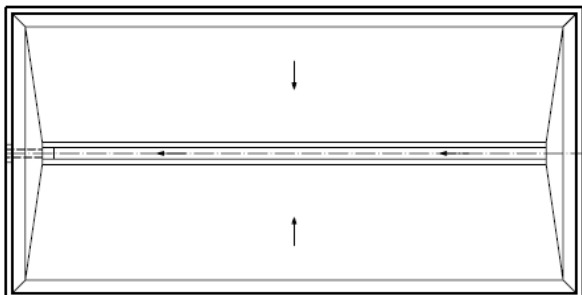

Type LR

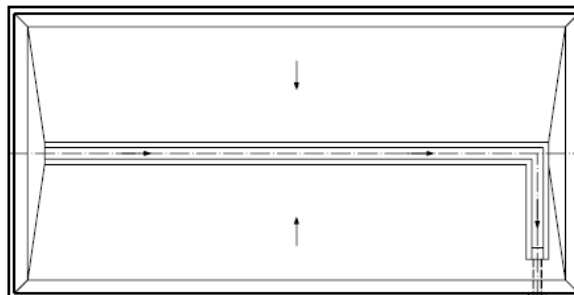

Type TR

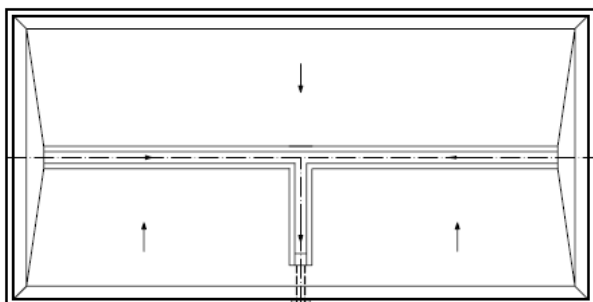

Type QR

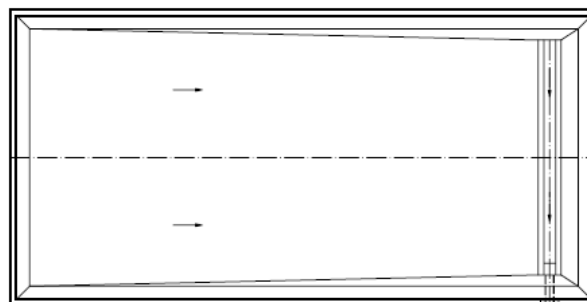

Type ME

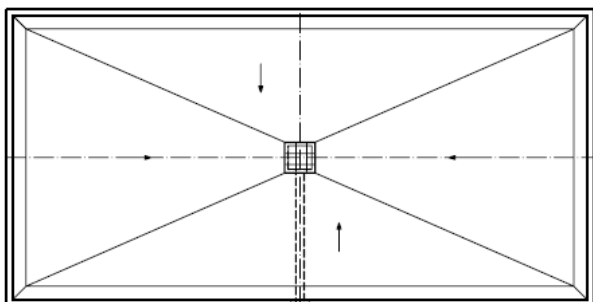

Type IR-KH

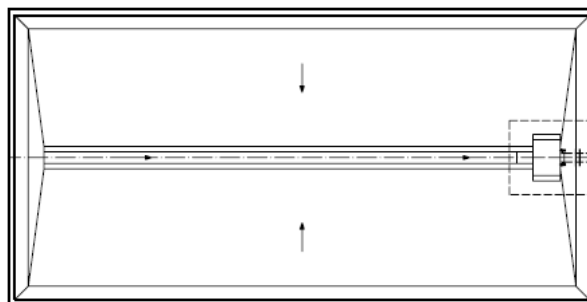

¹⁾ The maximal permissible speed should be 20 km/h to pass the pre fabricated elements.

B+F Motor Vehicle Load-Bearing Elements

Annex 2

Examples of pre-fabricated elements

Figure 1: Penetration behavior (mean penetration depth "e_{144m}" of liquids)¹⁾ on the basis of the respective dynamic viscosity and surface tension of the test liquids.

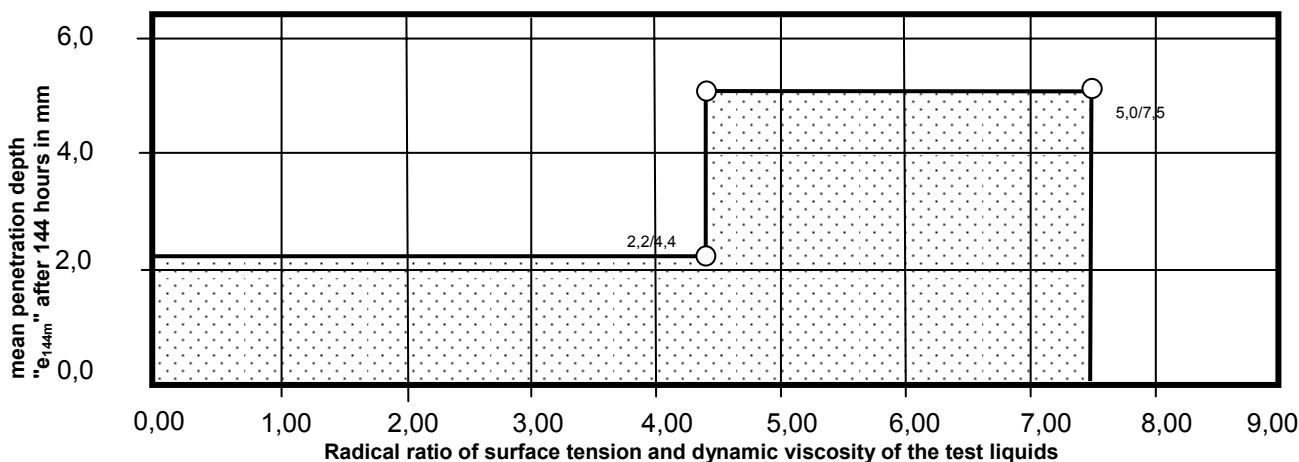

$$\sqrt{\frac{\sigma}{\eta}}, [m^{0,5}/s^{0,5}];$$

σ= surface tension [mN/m]
η= dynamic viscosity [mNs/m²]

¹⁾ safety factors^{*)} for determining the characteristic penetration depth and the minimum element thickness see Annex 10

Table 1: Materials and properties

No	Value	Requirement
1	Precast concrete	Liquid tight concrete according to the deposited information taking into account the provisions of this approval
	Aggregate	Aggregate according to the deposited information taking into account EN 12620:2003-4 and corrigenda 1 to EN 12620:2004-12
	Cement	Cement according to EN 197-1:2004-08
	Concrete admixture	FM and LP according to EN 934-2
2	Reinforcement	Reinforcing steel bars; reinforcing steel fabric within the meaning of EN 10080 taking into account the deposited information of the ETA holder
3	Drainage installation	according to the provisions of this approval and the requirements of the ETA holder Drain pipe: – Austenitic stainless steel e.g. according to EN 1124-1 – High density polyethylene, PE-HD according EN 12666-1 – Steel pipe according to EN 1123, hot-dip galvanized or – Pipes made of glass fibre reinforced polyester resin (UP-GF) according EN 14364 in connection with CEN/TS 14632:2006-09
4	Joint sealing system	Joint sealing systems (joint sealing compound systems, glued joint band systems) according to annex 4 with European and/or national approval for the respective intended use in SFH-facilities.
5	Transport and mounting device	According to the provisions of this approval and the deposited information
6	Surface protections: 6.1 Coating system	Trafficable coating systems with European and/or national approval suitable for the respective intended use in SFH-facilities.
	6.2 ceramic plates with Coating system	Surface sealing made of coating system with European and/or national approval and trafficable ceramic plates, which are permissible in accordance with the requirements of the respective Member States for the intended use in SFH-facilities, e.g. in G.: according to construction product list A (Bauregelliste A) Part 1, No. 15.31.
	6.3 ceramic plates with plastics sheets for the lining	Surface sealing made of plastics sheets for the lining with European and/or national approval and trafficable ceramic plates, which are permissible in accordance with the requirements of the respective Member States for the intended use in SFH-facilities, e.g. in G.: according to construction product list A (Bauregelliste A) Part 1, No. 15.31.

B+F Motor Vehicle Load-Bearing Elements

Annex 3

Penetration behavior, materials and properties

Table 1: Characteristic component and material values

No	Value	Requirement
Pre-fabricated elements		
1	Fresh concrete for pre-fabricated elements:	Concrete composition according to the deposited information
	- Monitoring class	2
	- Degree of compactability class	C1
	- Slump class	F3 to F6
	- Cement	CEM I 42,5 R
	- water/cement -value	0,43
	- Aggregate	according to the deposited information, alkali sensitivity class E I
2	Pre-fabricated elements:	Liquid-tight according to section 2.1.3 (1)
	- Monitoring class	2
	- Concrete compressive strength class	C35/45
	- Design state	State 2
	- Crack state class	$w_k \leq 0,1$ mm
	- Concrete cover	45 mm
	- Reinforcement	BSt 500 S (Mat.-no. 1.0438) and/or BSt 500 M (Mat.-no. 1.0466)
	- Exposure classes	XA3, XC4, XD3, XF4, XM2
	- Level of trafficability	t 0: pedestrians t 1: pneumatic-tyred vehicles to 60kN/(0,4x0,4)m ² t 2: pneumatic-tyred vehicles to 120kN/(0,4x0,4)m ² t 3: folk lift truck with pneumatic-tyred and/or solid rubber wheels to 0,8 N/mm ²
	- Class of wear and tear	XM1: moderate exposed to wear by means of pneumatic wheels XM2: strongly exposed to wear by means of air or solid rubber forklift truck lift
- Reaction to fire class	A1, when using in sealing constructions with joint sealing systems and/or surface protections, reaction to fire class of the relevant joint sealing system and/or surface protection (at least class "E") has to be observed	
3	Transport and mounting devices	Ball head anchor K32 and Flat steel anchor Rd 52
4	Joint width, if using joint sealing compound systems ¹⁾	$b \geq 16$ mm, < 20 mm

1) Joint widths bigger than 20 mm to 40 mm are only accessible by pedestrians.

2) The concrete meet the requirements of exposure classes XC4, XF3, XA3 and XM1

Transport and mounting devices

Geometry, material and installation

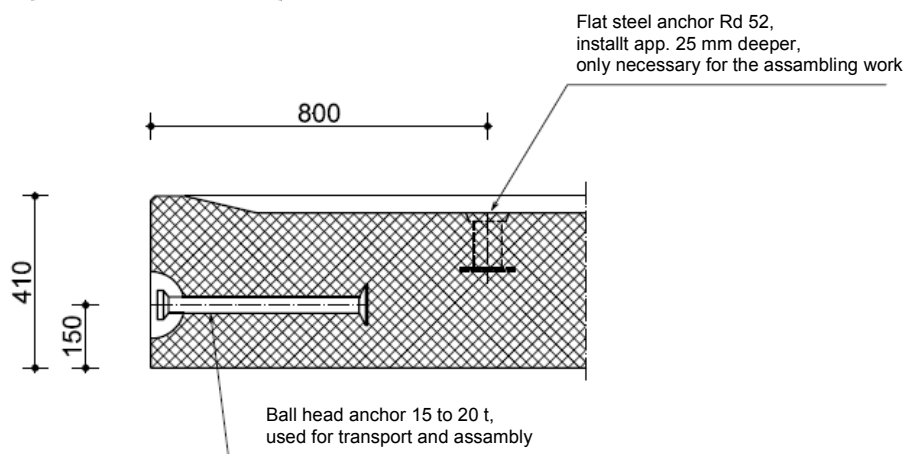

B+F Motor Vehicle Load-Bearing Elements

Annex 4

Characteristic component and material values,
Transport and mounting devices

English translation prepared by DIBt

Example of a joint sealing/ connection, schematic representation

- Connection to sealing surfaces, - constructions made of concrete and connection of the pre-fabricated elements with joint sealing compound systems: (ETA and/or national approval):

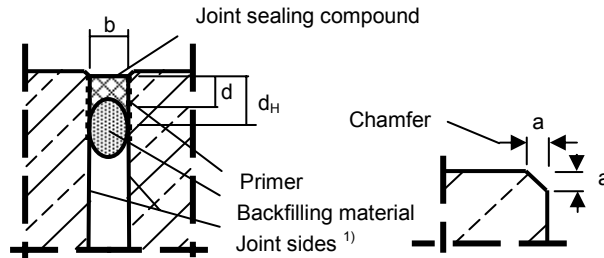

- a** = Chamfer edge 3-5 mm
- b** = Joint width
- d** = Thickness of the joint sealing compound
- d_H** = Joint sealing compound bonding or contact surface on the joint side wall (protected joint side) $d_H = \gamma_s \cdot e_{tm}$
- e_{tm}** = mean penetration depth; see Annex 2, Figure 1,
- γ_s** = Safety factor for determining the characteristic penetration depth, Annex 9
- 1)** = The joint sides shall be aligned parallel to one another

- Connection of the pre-fabricated elements with glued sealing band systems (ETA and/or national approval):

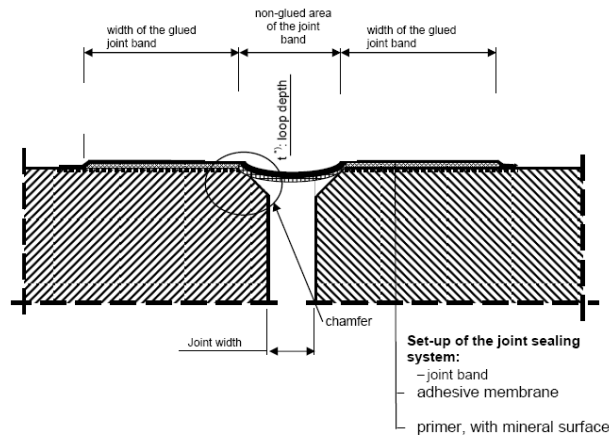

t = hog depth of the loop

Basis of the pre fabricated elements

ie:

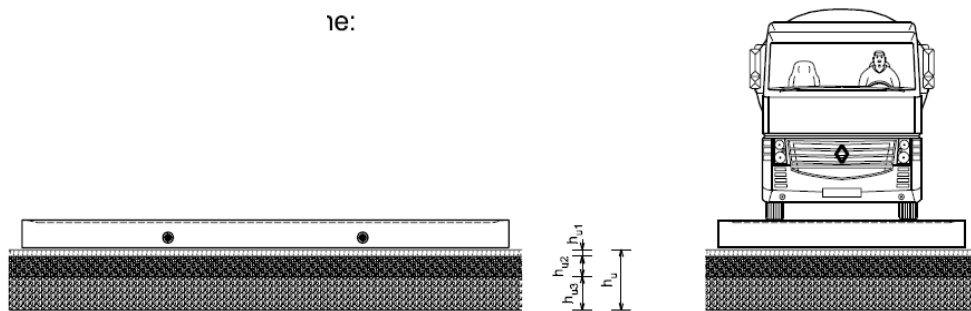

Table 1: Values for the basis of the pre fabricated elements^{1), 2)}

No	Level name	Grain size/ Description of the level	Height of the level (h _u ≥ 500 mm)		
			h _{u1} , [mm]	h _{u2} , [mm]	h _{u3} , [mm]
1	Fine chip	Grain size 2-8 mm, as fine-grading	≥ 50 ³⁾	-	-
2	Gravel and/or chip mixture	Grain size 8-16 mm	-	≥ 150 ³⁾	-
3	Ballast	Grain size 0-45 mm, crashed	-	-	≥ 300 ³⁾

¹⁾ Modulus of volume change of the basis: E_s ≥ 80 MN/m²

²⁾ Permissible ground pressure: ≤ 250 kN/m²

³⁾ The basis has to be built frost free, at least ≥ h_{ux}.

B+F Motor Vehicle Load-Bearing Elements

Annex 5

Examples of joint sealing and –connections

Pre-fabricated element Type IR

Table 1: Geometry of Type IR

Type	Designation	Length l^1	Width b^1	b_1	b_2	Thickness h	l_k	h_{KT}	h_{FL}
		[mm]	[mm]	[mm]	[mm]	[mm]	[mm]	[mm]	[mm]
IR	Length trough	5000 - 8000	3800 - 4000	1900 - 2000		410	1500	150	1750 - 2000

1) Adaptation geometries of 5000 mm x 3800 mm to 8000 mm x 4000 mm are permissible.

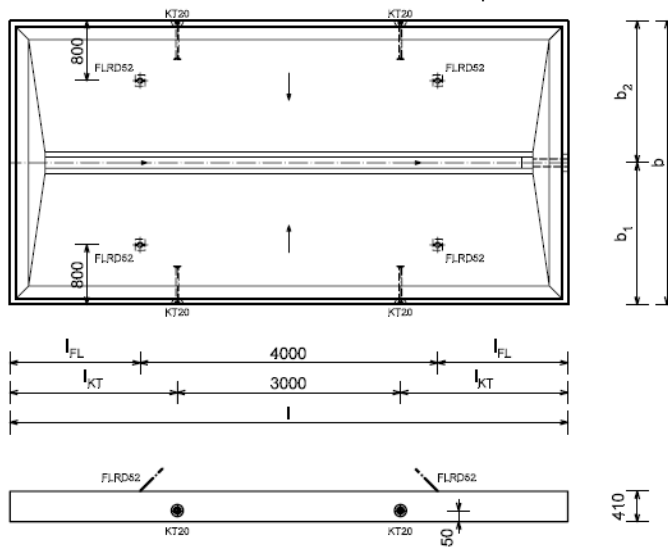

Pre-fabricated element Type TR

Table 2: Geometry of Type TR

Type	Designation	Length l^1	Width b^1	b_1	b_2	Thickness h	l_k	h_{KT}	h_{FL}
		[mm]	[mm]	[mm]	[mm]	[mm]	[mm]	[mm]	[mm]
IR	T- trough	5000 - 8000	3800 - 4000	1900 - 2000		410	150	150	1750 - 2000

1) Adaptation geometries of 5000 mm x 3800 mm to 8000 mm x 4000 mm are permissible.

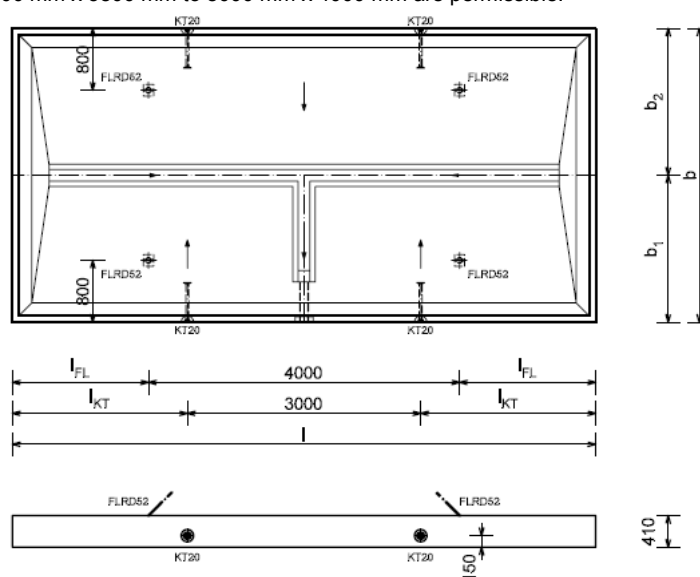

B+F Motor Vehicle Load-Bearing Elements

Annex 6

Pre-fabricated elements, Type IR and TR

English translation prepared by DIBt

Pre-fabricated element Type MR

Table 2: Geometry of Type MR

Type	Designation	Length ℓ^1	Width b^1	b_1	b_2	Thickness h	ℓ_k	h_{KT}	h_{FL}
		[mm]	[mm]	[mm]	[mm]				
IR	middle- drainage	5000 - 8000	3800 - 4000	1900 - 2000		410	1500	150	1750 - 2000

1) Adaptation geometries of 5000 mm x 3800 mm to 8000 mm x 4000 mm are permissible.

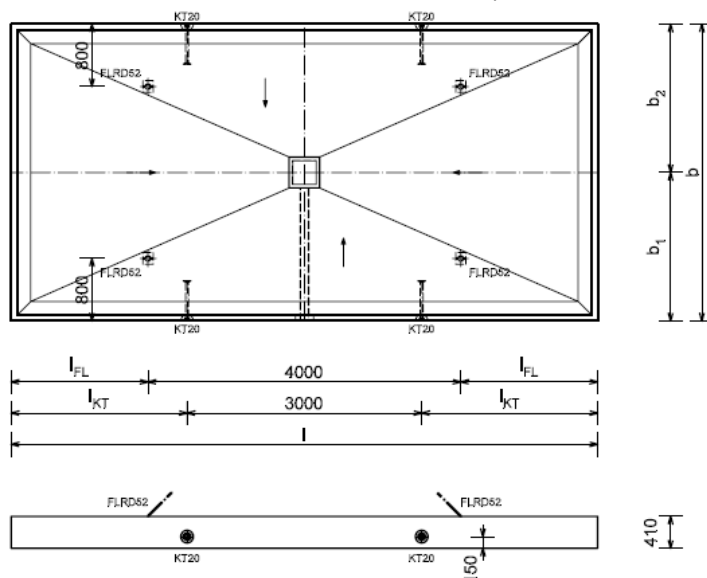

Pre-fabricated element Type IR-KH

Table 2: Geometry of Type IR-KH (with ball cock)

Type	Designation	Length ℓ^1	Width b^1	b_1	b_2	Thickness h	ℓ_k	h_{KT}	h_{FL}
		[mm]	[mm]	[mm]	[mm]				
IR-KH	Length trough	5000 - 8000	3800 - 4000	1900 - 2000		410	1500	150	1750 - 2000

1) Adaptation geometries of 5000 mm x 3800 mm to 8000 mm x 4000 mm are permissible.

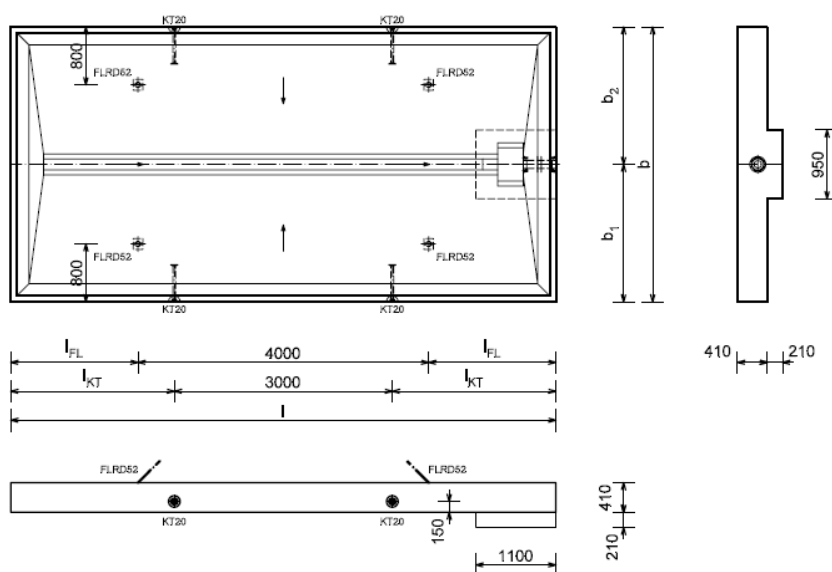

B+F Motor Vehicle Load-Bearing Elements

Pre-fabricated elements, Type MR and IR-KH

Annex 7

Pre-fabricated element Type LR

Table 1: Geometry of Type LR

Type	Designation	Length ℓ^1	Width b^1	b_1	b_2	Thickness h	ℓ_k	h_{KT}	h_{FL}
		[mm]	[mm]	[mm]	[mm]				
LR	Length trough	5000 - 8000	3800 - 4000	1900 - 2000		410	1500	150	1750 - 2000

1) Adaptation geometries of 5000 mm x 3800 mm to 8000 mm x 4000 mm are permissible.

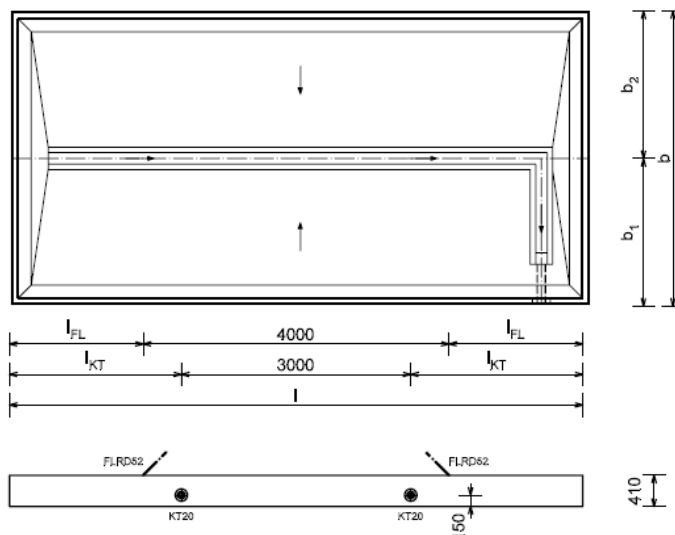

Pre-fabricated element Type QR

Table 2: Geometry of Type QR

Type	Designation	Length ℓ^1	Width b^1	b_1	b_2	Thickness h	ℓ_k	h_{KT}	h_{FL}
		[mm]	[mm]	[mm]	[mm]				
QR	cross trough	5000 - 8000	3800 - 4000	1900 - 2000		410	1500	150	1750 - 2000

1) Adaptation geometries of 5000 mm x 3800 mm to 8000 mm x 4000 mm are permissible.

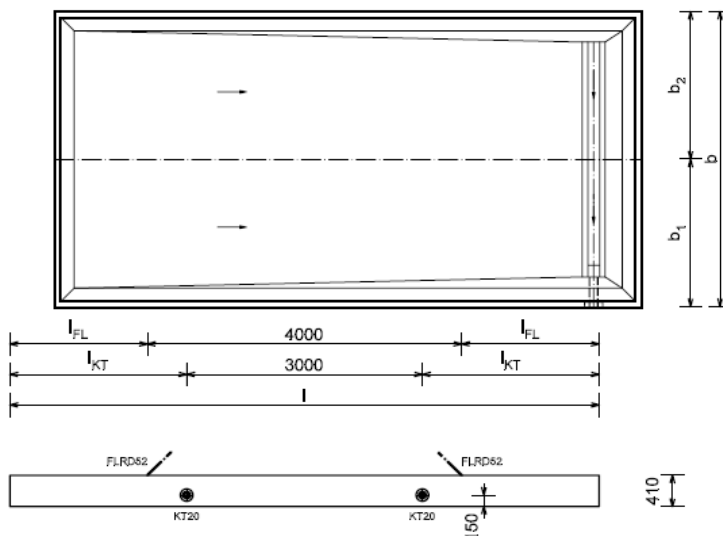

B+F Motor Vehicle Load-Bearing Elements

Pre-fabricated elements, Type LR and QR

Annex 8

Drainages for fields of applications the backflow into the pre-fabricated element can not be excluded:

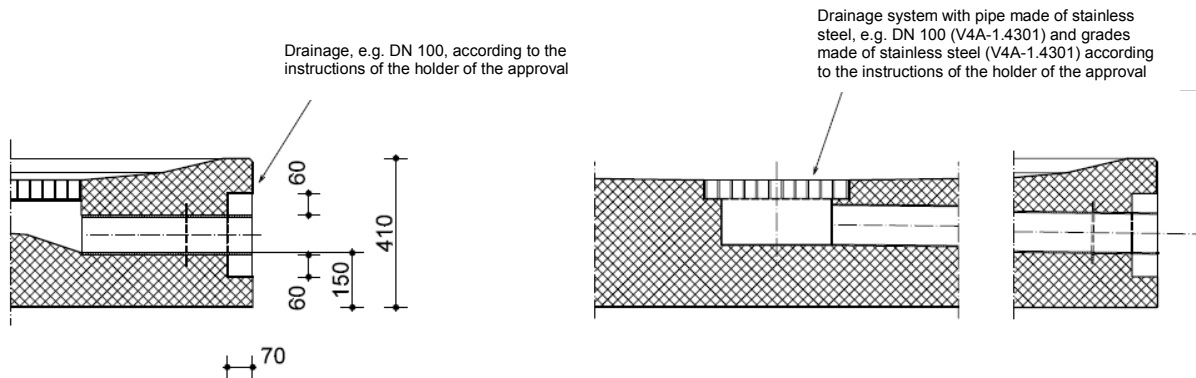

- Drainage connection DN 100 and/or DN 150
- The connection is only permissible welded and/or glued.
- **Material according to Annex 2, Table 1:**
 - Austenitic stainless steel,
 - High density polyethylene, PE-HD,
 - Steel pipe, hot-dip galvanized or
 - Pipes made of glass fiber reinforced polyester resin (UP-GF)

Drainages above grounds for fields of applications the free flow off of the liquids (without backflow) over slopes to the collecting installation^{*)} is guaranteed:

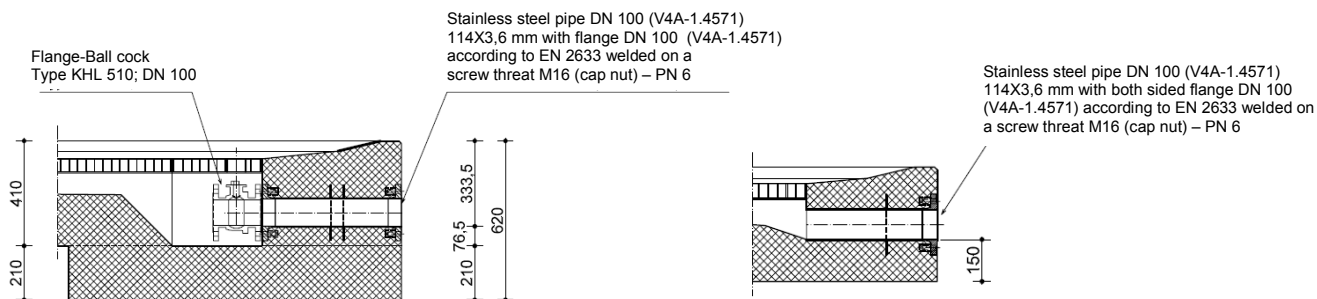

- Drainage connection DN 100 and/or DN 150
- Advice: Removable connections are only assessable with suitable sealing materials/ -profiles. The connections have to meet among other things the requirements of EN 681-1 and have to be resistant to the liquids mentioned in Annex 2, e.g. in G. on basis of "BAM-List"
- **Material according to Annex 2, Table 1:**
 - Austenitic stainless steel,
 - High density polyethylene, PE-HD,
 - Steel pipe, hot-dip galvanized or
 - Pipes made of glass fiber reinforced polyester resin (UP-GF)

^{*)} The collecting installation has to be designed that the complete foreseeable collecting volum (e.g. rain and leaking liquids hazardous to water) can be collected in the collecting installation.

B+F Motor Vehicle Load-Bearing Elements	Annex 9
Examples for collecting installation	

1. Stress levels for the impact:

1.1 Pre-fabricated elements in the area of storage

The stress of the pre-fabricated elements when storing shall be determined in individual cases according to the operating conditions taking into account the relevant national provisions of the countries. It is dependent amongst others on the duration of stress determined. Within this duration of stress determined the leaked liquids must be identified and removed from the sealing construction.

Table 1: Storing of substances hazardous to water

Abbreviation	Stress level	Duration of stress	Testing period
S ₁	low	Duration of stress up to 8 hours ¹⁾	8 hours
S ₂	mean	Duration of stress up to 72 hours ¹⁾	72 hours
S ₃	high	Duration of stress up to 3 months ^{1), 2)}	2200 hours

¹⁾ In this period of the duration of stress the stress is to be identified and removed, the sealant is to be cleaned and (if applicable, after the professional judgment) put into operation again.

²⁾ In case of duration of stress over 3 months, a permanent impact shall be assumed and the determinations given in this ETA shall not be applied.

1.2 Pre-fabricated elements in the area of filling and handling:

The stress of the pre-fabricated elements when filling and handling will be determined in individual cases taking into account the operating conditions. It is dependent on the frequency of the filling procedures, on the infrastructure and on the national provisions of the countries regarding the legal dangerous substances requirements for packing of substances hazardous to water.

Reloading and filling processes will be constantly visual checked for dripping losses and leakages, so that the measures on their elimination can be disposed immediately.

Table 2: Filling and Handling of substances hazardous to water

Abbreviation	Stress level	Frequency / measure	Testing period
F ₁ , H ₁	low	a) Filling up to 4 x per annum. b) Handling of substances in suitable packing ¹⁾	8 hours
F ₂ , H ₂	mean	a) Filling up to 200 x per annum. b) Handling of substances in not suitable packing ¹⁾	Impact cycle: 28 days per 5 hours ²⁾
F ₃	high	Filling and handling without restriction of the frequency	Impact cycle: 40 days per 5 hours ³⁾

¹⁾ According to the national provisions of the countries regarding the legal dangerous substances requirements for packing of substances hazardous to water.

²⁾ Equivalent impact (same penetration depth) one-time 144 hours.

³⁾ Equivalent impact (same penetration depth) one-time 200 hours.

2. Safety factors for determining the characteristic penetration depth and the minimum component thickness:

Safety factor γ_s : Failing an agreement to the contrary, the safety factor for the static deviation from the individual values of the penetration depths is 1,35. As opposed to this it may be determined according to the provisions of the respective Member States.

Safety factor γ_e : Failing an agreement to the contrary, the safety factor for the penetration depth is 1,5 based on the specifications of the supervision and testing and during the use of the pre-fabricated components (installation surveillance). As opposed to this it may be determined according to the provisions of the respective Member States.

B+F Motor Vehicle Load-Bearing Elements

Annex 10

Stress levels for the impact and safety factors