

## European Technical Approval ETA-10/0270

English translation prepared by DIBt - Original version in German language

Handelsbezeichnung <i>Trade name</i>	Eurolastic TC 30 S, schwarz <i>Eurolastic TC 30 S, black</i>
Zulassungsinhaber <i>Holder of approval</i>	Euroteam Bauchemie GmbH An der Mühle 1 15345 Altlandsberg DEUTSCHLAND
Zulassungsgegenstand und Verwendungszweck  <i>Generic type and use of construction product</i>	Eurolastic TC 30 S, schwarz als Bestandteil des Fugenabdichtungssystems der Euroteam Bauchemie GmbH zur Verwendung in Anlagen zum Lagern, Abfüllen und Umschlagen wassergefährdender Stoffe  <i>Eurolastic TC 30 S, black as a part of the joint sealing system of the Euroteam Bauchemie GmbH used in facilities for the storage, filling and handling of substances hazardous to water</i>
Geltungsdauer: <i>Validity:</i>	vom <i>from</i> bis <i>to</i>
	8 August 2011 9 December 2015
Herstellwerk <i>Manufacturing plant</i>	Euroteam Bauchemie GmbH An der Mühle 1 15345 Altlandsberg DEUTSCHLAND

Diese Zulassung umfasst  
*This Approval contains*

23 Seiten einschließlich 10 Anhänge  
*23 pages including 10 annexes*

Diese Zulassung ersetzt  
*This Approval replaces*

ETA-10/0270 mit Geltungsdauer vom 10.12.2010 bis 09.12.2015  
*ETA-10/0270 with validity from 10.12.2010 to 09.12.2015*

## I LEGAL BASES AND GENERAL CONDITIONS

- 1 This European technical approval is issued by Deutsches Institut für Bautechnik in accordance with:
  - Council Directive 89/106/EEC of 21 December 1988 on the approximation of laws, regulations and administrative provisions of Member States relating to construction products<sup>1</sup>, modified by Council Directive 93/68/EEC<sup>2</sup> and Regulation (EC) N° 1882/2003 of the European Parliament and of the Council<sup>3</sup>;
  - Gesetz über das In-Verkehr-Bringen von und den freien Warenverkehr mit Bauprodukten zur Umsetzung der Richtlinie 89/106/EWG des Rates vom 21. Dezember 1988 zur Angleichung der Rechts- und Verwaltungsvorschriften der Mitgliedstaaten über Bauprodukte und anderer Rechtsakte der Europäischen Gemeinschaften (Bauproduktengesetz - BauPG) vom 28. April 1998<sup>4</sup>, as amended by law of 31 October 2006<sup>5</sup>;
  - Common Procedural Rules for Requesting, Preparing and the Granting of European technical approvals set out in the Annex to Commission Decision 94/23/EC<sup>6</sup>.
- 2 Deutsches Institut für Bautechnik is authorized to check whether the provisions of this European technical approval are met. Checking may take place in the manufacturing plant. Nevertheless, the responsibility for the conformity of the products to the European technical approval and for their fitness for the intended use remains with the holder of the European technical approval.
- 3 This European technical approval is not to be transferred to manufacturers or agents of manufacturers other than those indicated on page 1, or manufacturing plants other than those indicated on page 1 of this European technical approval.
- 4 This European technical approval may be withdrawn by Deutsches Institut für Bautechnik, in particular pursuant to information by the Commission according to Article 5(1) of Council Directive 89/106/EEC.
- 5 Reproduction of this European technical approval including transmission by electronic means shall be in full. However, partial reproduction can be made with the written consent of Deutsches Institut für Bautechnik. In this case partial reproduction has to be designated as such. Texts and drawings of advertising brochures shall not contradict or misuse the European technical approval.
- 6 The European technical approval is issued by the approval body in its official language. This version corresponds fully to the version circulated within EOTA. Translations into other languages have to be designated as such.

<sup>1</sup> Official Journal of the European Communities L 40, 11 February 1989, p. 12  
<sup>2</sup> Official Journal of the European Communities L 220, 30 August 1993, p. 1  
<sup>3</sup> Official Journal of the European Union L 284, 31 October 2003, p. 25  
<sup>4</sup> *Bundesgesetzblatt Teil I 1998*, p. 812  
<sup>5</sup> *Bundesgesetzblatt Teil I 2006*, p. 2407, 2416  
<sup>6</sup> Official Journal of the European Communities L 17, 20 January 1994, p. 34

## II SPECIFIC CONDITIONS OF THE EUROPEAN TECHNICAL APPROVAL

### 1 Definition of the product/products and intended use

#### 1.1 Definition of the construction product

(1) The joint sealing system of the Euroteam Bauchemie GmbH (in the following called "joint sealing system"), is made of:

- Primer,
- stable joint sealing compound "Eurolastic TC 30 S, black", (in the following called "joint sealing compound") and
- backfill material.

(2) The following primers are given by the manufacturer of the joint sealing system especially for the respective contact material.

- "Eurolastic Primer U12 G" for sealing constructions made of concrete (precast concrete elements and/or in-situ concrete) and fibre concrete
- "Eurolastic Primer S2" for sealing constructions made of polymer-concrete based on UP resin
- "Eurolastic Primer ZM" for sealing constructions made of steel and for parts of sealing constructions made of CD-coated steel (cathodic dip coating only permitted on the basis of aminated, water-insoluble epoxy resin on bisphenol-A).

(3) A closed-cell backfill material, compatible with the joint sealing compound, is used.

(4) The joint sealing compound is placed in the prepared joint recesses of finished structural elements made from different construction materials (contact material) in a plastic state. There it reacts to form a joint sealing compound with predominantly elastic properties.

(5) The joint sealing compound and the respective primer are matched with the intended contact material, e.g. concrete, fibre concrete, polymer-concrete or steel. The respective suitable primer is applied to the joint sidewalls before the joint sealing compound is placed.

(6) The joint sealing compound system is applied with a defined ratio of thickness "d" to width "b" (see Annex 1). Evidence of suitability of the respective joint geometry was provided within the scope of the approval tests.

#### 1.2 Intended use

(1) The joint sealing system is intended for use in plants for the containment, handling and filling of certain substances hazardous to water both inside as well as outside of buildings.

(2) It shall be used for sealing of movement joints, which shall allow unrestrained deformation of structural elements (e.g. shrinkage, temperature-dependent alterations in length or the effects of different ground deformations) and, with regard to their sealing function, shall not be adversely affected.

(3) The joint sealing system may be used under constantly changing mechanical actions due to traffic with pedestrians and /or traffic actions by pneumatic tyres.

(4) The joint sealing compound system may be installed at normal environmental, structural element and material temperatures (usually within a range of + 5 °C to + 40 °C) and used at temperatures between –20 °C and + 70 °C. The temperature of the water contaminating liquid in contact with the joint sealing system shall not be higher than 30 °C.

(5) The provisions made in this European technical approval are based on an assumed working life of the joint sealing compound of 10 years. The indications given on the working life cannot be interpreted as a guarantee given by the producer, but are to be regarded only as a means for choosing the right products in relation to the expected economically reasonable working life of the works.

## 2 Characteristics of the product and methods of verification

### 2.1 General

(1) The joint sealing system shall correspond to the drawings and the details of the annexes of this approval.

(2) The chemical composition or the formula of the joint sealing compound and of the primer shall correspond to the information deposited with Deutsches Institut für Bautechnik.

(3) The characteristics of the material, the dimensions and tolerances which are not declared in this approval shall correspond to the information laid down in the technical documentation<sup>7</sup> of this European technical approval.

### 2.2 Characteristics

(1) The joint sealing system

- is resistant to the liquids listed in Annex 2 for the stress level S1, H1, F1 "low", S2, H2, F2 "medium" and/or S3, F3 "high" (definition of stress levels see Annex 10),
- is resistant to hydrolysis in consideration of ISO 868: 2003-03 and weather according to EN 14187-8:2003-06,
- is stable,
- is suitable to be attached to certain admissible contact materials (see Annex 5, Table 1) and
- is suitable to be directly applied onto joint sealing compound of this approval that has already hardened.

(2) The joint sealing system (see Annex 1 and Annex 3, Table 1 and figure 1)

- is accessible for pedestrians according to the level of trafficability "t0" and/or passable by vehicles according to the level of trafficability "t1" (see Annex 4, Table 1 in conjunction with Annex 3, Table 1),
- is classified in the class of wear and tear "XM1" (see Annex 4, Table 1),
- is suitable to take up the extension, compression and shear deformations documented in Annex 7, Table 1 in the area of parallel joint side walls as well as tee and cross intersections without becoming leaky and
- under consideration of the determinations of Annex 3, figure 1 prevents migration of the liquids listed in Annex 2 in the area of the joint.

<sup>7</sup>

The technical documentation of this European technical approval is deposited with Deutsches Institut für Bautechnik and shall be made available to the approved bodies, who are involved in the procedure of conformity attestation, for the fulfilment of their tasks.

(3) The joint sealing compound together with the respective primer used between contact materials according to clause 1.1 (2) meets the requirements of the reaction-to-fire class E in accordance with EN 13501-1<sup>8</sup> (see Annex 4, Table 1). The used backfill material has at least to meet the requirements for building products of reaction-to-fire class E in accordance with EN 13501-1<sup>8</sup>.

## 2.3 Composition

(1) The joint sealing system is made of:

- **joint sealing compound**

"Eurolastic TC 30 S, black"

consisting of the components A and B, the basis material of which is polysulfide.

- **primer**

- sealing constructions made of concrete and fibre concrete:

"Eurolastic Primer U12G"

consisting of the components A and B, the base material of which is epoxy resin.

- sealing constructions made of polymer-concrete on UP-resin base:

"Eurolastic Primer S2"

a one-component primer on silane base.

- sealing constructions made of steel and for parts of sealing constructions made of CD-coated steel:

"Eurolastic Primer ZM"

consisting of components A and B, the base material of which is epoxy resin.

- **Backfill material**

A closed-cell backfill material, compatible with the joint sealing compound, is to be chosen and to be used in accordance with the provisions by the manufacturer according to the following criteria:

- A backfill material is to be chosen which prevents the adhesion of the joint sealing compound to the ground of the joint. The backfill material has to be installed sufficiently stable and with the same height "d" (see Annex 1) to observe the dimensions of the joint depth.
- The backfill material shall be installed in such a way that it shows an elliptical cross-section (see Annex 1). It shall be compatible with the joint sealing compound and shall be closed-cell.
- The backfill material shall not inadmissibly impede the change in shape of the joint sealing compound and shall not contain any substances which weaken the adhesion of the joint sealing compound on the joint sidewalls.
- It may not cause discolorations or bubbles.
- At built-in state the backfill material shall offer sufficient resistance when placing the joint sealing compound.

(2) More information about the individual components of the joint sealing system (mix ratio, airing out, etc.) is given in Annex 4, Table 1.

## 2.4 Emission of dangerous substances

(1) According to the manufacturer's declaration the joint sealing system taking account of the EU database<sup>9</sup> does not contain any dangerous substances.

<sup>8</sup> EN 13501-1: Fire classification of construction products and building elements

<sup>9</sup> References in Guidance Paper H: A harmonised approach with regard to the handling of dangerous substances according to the Construction Products Directive, Brussels 18 February 2000

(2) Within the scope of this approval there may be other requirements applicable to dangerous substances resulting from transposed European legislation or applicable national regulations and administrative provisions. These requirements need also to be complied with.

(3) There may be other requirements applicable to the products resulting from other applicable national regulations and administrative provisions. These requirements need also to be complied with.

### 3 Evaluation and attestation of conformity and CE marking

#### 3.1 System of attestation of conformity

The European Commission according to its decision on the procedure of attestation of conformity 2003/656/EC of 12 September 2003 (Official Journal of the European Union No L 231 of 17 September 2003) has laid down for joint sealing compounds (EOTA-Nr. 06.05/11) system 2+ for the procedure of attestation of conformity (AoC) (Annex III, clause 2(ii) first possibility of Directive 89/106/EEC) for this type of material.

The AoC System 2+ provides:

- a) Tasks for the manufacturer:
- Initial type-testing of the joint sealing compound and the primer
  - Factory production control including continuous testing of samples taken at the factory
- b) Tasks for the approved bodies:
- Inspection body: Initial inspection as well as continuous surveillance, assessment and approval of factory production control.
  - Certification body: Granting of a certificate of conformity.

#### 3.2 Responsibilities

##### 3.2.1 Tasks for the manufacturer

###### 3.2.1.1 Factory production control

1) The manufacturer shall set up and perform a factory production control. Factory production control means the continuous surveillance of the production to be performed by the respective manufacturer, whereby it is ensured that the products manufactured by him correspond to the provisions of the European technical approval.

(2) The manufacturer has to perform continuous surveillance of the production process in accordance with the prescribed control plan<sup>10</sup>.

(3) The manufacturer may only use initial materials in accordance with the information deposited (according to) in section 2.1(2). He shall inspect or control the initial materials on acceptance according to the prescribed control plan.

(4) The factory production control follows the properties given in the Common Understanding of Assessment Procedure. They are specified in the technical documentation.

(5) The results of the factory production control shall be recorded and evaluated. The records shall include at least the following information:

- Description of the product, of the initial materials,
- type of inspection or test,

<sup>10</sup>

The control plan is deposited with Deutsches Institut für Bautechnik and contains the required information on the factory production control and on the initial type-testing. As far as this is relevant to the tasks of the approved body involved in the procedure of attestation of conformity the control plan will be handed over to the approved body.

- date of the manufacture of the product, batch N°, if need be, and date of the inspection or test of the product / the initial materials,
- results of the inspections or tests and, if applicable, comparison with the requirements,
- signature of the person responsible for the factory production control.

(6) The records shall be kept for a minimum of five years. On request they shall be presented to Deutsches Institut für Bautechnik.

(7) Details concerning extent, type and frequency of the tests or inspections to be performed within the scope of the factory production control shall correspond to the prescribed control plan<sup>10</sup> which is part of the technical documentation to this ETA.

#### 3.2.1.2 Other tasks for the manufacturer

The manufacturer shall, on the basis of a contract, involve a body which is approved for the tasks referred to in section 3.1 in the field of joint sealing compounds for the sealing of construction works for the containment, handling and filling of water-endangering substances in order to undertake the actions laid down in section 3.2.2.

The manufacturer shall make a declaration of conformity, stating that the construction product is in conformity with the provisions of this European technical approval.

### 3.2.2 Tasks for the approved bodies

#### 3.2.2.1 Inspection body

(1) In each factory where the joint sealing compound is manufactured an initial inspection as well as the factory production control shall be performed by an inspection body.

(2) An inspection body shall continuously control, assess and approve the effectiveness of the factory production control in accordance with the requirements of the control plan<sup>10</sup>. The continuous surveillance shall take place at least twice a year.

(3) On demand the results of the surveillance shall be presented by the inspection body to Deutsches Institut für Bautechnik and, if necessary, to the relevant authority.

(4) The verifications, on which the ETA is based, were furnished by samples taken from the current production, thus only a reduced initial type-testing according to the specifications in the control plan<sup>10</sup> shall be performed.

(5) Observance of the required property values shall be ascertained by the inspection body.

#### 3.2.2.2 Certification body

(1) The certification of the factory production control by a certification body is based on the initial inspection of the manufacturing plant and of the factory production control as well as of the continuous surveillance, assessment and approval of factory production control according to the provisions given in clause 3.2.1.1.

(2) The approved certification body involved by the manufacturer shall issue an EC certificate of conformity of the factory production control stating the conformity with the provisions of this European technical approval.

(3) In cases where the provisions of the European technical approval and its control plan are no longer fulfilled the certification body shall withdraw the certificate of conformity and inform Deutsches Institut für Bautechnik without delay.

### 3.3 CE marking

The CE marking<sup>11</sup> shall be affixed on the delivery containers, on the packaging of the components of the joint sealing system, on the delivery note, on signs or labels. The letters "CE" shall be followed by the identification number of the approved certification body, where relevant, and be accompanied by the following additional information:

The CE marking shall be accompanied by the following:

<sup>11</sup> Notes on the CE marking and the declaration of conformity by the manufacturer are stated in Guidance Paper D "CE marking under the Construction Products Directive", Brussels, 1 August 2002

- Name or identifying mark of the manufacturing plant
- last two digits of the year in which the CE marking was affixed
- number of the certificate on the factory production control (system 2+)
- name of the product
- number of the ETA
- essential properties:
  - reaction-to-fire class,
  - admissible contact material,
  - admissible extension, compression and shear distances in millimetres,
  - admissible levels of road serviceability and
  - resistance to media shall be given with the wording "Resistance to media in accordance with Annex 2 of the ETA".

#### **4 Assumptions under which the fitness of the product for the intended use was favourably assessed**

##### **4.1 Manufacturing**

(1) The manufacture and or the make of the individual components of the joint sealing compound and the primer shall be in accordance with the details deposited with Deutsches Institut für Bautechnik and carried out at the manufacturing plant of the holder of the approval, Euroteam Bauchemie GmbH, An der Mühle 1, 15345 Altlandsberg, Germany. Modifications are subject to prior consent by Deutsches Institut für Bautechnik.

(2) The European technical approval is issued for the product on the basis of agreed data/information, deposited with Deutsches Institut für Bautechnik, which identifies the product that has been assessed and judged. Changes to the product or production process, which could result in this deposited data/information being incorrect, should be notified to Deutsches Institut für Bautechnik before the changes are introduced. Deutsches Institut für Bautechnik will decide whether or not such changes affect the approval and consequently the validity of the CE marking on the basis of the approval and if so whether further assessment or alterations to the approval shall be necessary.

##### **4.2 Installation**

###### **4.2.1 Conditions for the installation**

- (1) The joint sealing system is planned and designed by expert designers only.
- (2) The joints are designed such that they can be controlled during subsequent use.
- (3) For the proper installation of the joint sealing system the manufacturer of the joint sealing system draws up installation and handling instructions, which are deposited as part of the technical documentation with Deutsches Institut für Bautechnik.
- (4) Joint sealing compounds which are installed in potentially explosive areas do not insulate conductive parts.
- (5) The additional instructions and technical advice given by the manufacturer are paid attention to, e.g. concerning the condition of the joint side walls and adjacent building components or surface sealants.
- (6) The suitability for the respective intended use results from the contact material and the indicated levels and/or performance classes of the categories of use.



- (7) Controllable calculations and construction drawings (e.g. joint plans) are made up taking account of the requirements at national level of the respective countries and the stresses and loadings to be expected.
- (8) The movable joints are arranged such that the admissible extension, compression and shear distances referred to in Annex 7, Table 1 are complied with.
- (9) The following is considered for design and dimensioning:
- Joint sealing compounds are arranged such that they can be used– within the scope of the stress level "low", "medium" and/or "high" according to Annex 2– with liquids hazardous to water or that an accumulation of a mixture of dirt and liquids hazardous to water is avoided on the joint sealing compounds. In particular, it is ensured that there is no joint sealing system in the immediate area under filling points.
  - The joint side walls shall have enough strength and load-bearing capacity that they are able to accept the occurring stresses acting on them through the joint sealing compound.
  - The liquid proof surfaces and/or constructions to be connected shall be designed such that the admissible deformations according to Annex 7, Table 1 (e.g. due to temperature, residual shrinkage or creep) are observed.
  - In accordance with the national requirements of the respective country, the surface sealant (e.g. concrete, polymer-concrete on UP-resin base, uncoated steel) in which and/or on which the joint sealing system is installed may only show limited penetration depths of liquids. The characteristic penetration depth of the respective liquid in the surface sealant, e.g. made of concrete, shall be smaller than the area of the joint side wall protected by the joint sealing compound "d<sub>H</sub>" (see also Annex 3, figure 1).

#### 4.2.2 Processing

- (1) Requirements for the performing company can result from national provisions of the Member States.
- (2) Furthermore the installation of joint sealing systems is carried out by companies who (including their specialists) are authorised and trained by the manufacturer.
- (3) Fitness for use of the installed joint sealing systems can only be assumed, if the processing is performed according to the provisions of this ETA and according to the supplementing installation and processing instructions by the manufacturer.
- (4) It is to be checked whether the system components of the sealing compound and the primer were not exchanged.
- (5) It is to be guaranteed that the maximum admissible joint width according to Annex 3, Table 1 will be warranted observed.
- (6) Before the installation of the joint sealing system the suitability of the joints side walls and the building components to be connected is to ascertain.
- In the case of concrete sealing constructions the concrete of the contact surfaces shall have reached at the time of jointing at least 70% of the 28-days-strength and be at least 7 days old.
  - The joint side walls shall be dry and may not show any impurities.
  - Accumulations of precipitation behind joint sealing compounds already installed are to be prevented.
  - The surface temperature of the building elements in the area of the joints shall be at least 3 K above thawing temperature during the installation of the joint sealing compound.
  - The primer shall be applied evenly on the respective joint side walls. The primer will be applied according to the installation instructions by the manufacturer.

- The classification of the different primers to the respective contact materials (concrete, fibre concrete, polymer-concrete on UP resin base, uncoated steel, CD-coated steel) shall be strictly observed.
- (7) When installing the joint sealing system the specifications made by the manufacturer or the designing engineer (see e.g. the drawing of the joint) shall be observed.
- (8) At temperatures of the building component below 5 °C and above 40 °C jointing may not be performed.
- (9) The joint sealing compound may not be applied on layers of condensation moisture.
- (10) The joint sealing compound and the respective primer respectively shall be mixed according to manufacturer's instructions.
- (11) The time interval given in Annex 4, Table 1, between applying the primer and installing the joint sealing compound (airing out) may not fall below or be exceeded.
- (12) The primer and the joint sealing compound are to be applied evenly and as blister-free as possible.
- (13) The release for mechanical and chemical stresses of the sealing construction may only be performed after the period indicated in Annex 4, Table 1 after complete installation of the joint sealing system. For the period of reaction the sealing compound shall be protected from atmospheric exposure in accordance with the definitions by the manufacturer.
- (14) The attestation of conformity of the installed joint sealing system with the determinations of this ETA and according to the supplementing installation and processing instructions by the manufacturer will take place by the installing company according to section 4.2.2 (1) and (2) by means on a report on the production (see Annex 9) based on the controls of the execution in accordance with section 4.2.4.

#### 4.2.3 Repair works

- (1) Companies according to clause 4.2.2 (1) and (2) are charged with the repair works.
- (2) The section to be repaired shall be separated from the intact section by conducting a vertical cut.
- (3) The defective material shall be removed completely. Unevenness, defects or edges in the area of the joint side walls shall be repaired in accordance with the determinations of section 4.2. When using repair systems made of concrete with polymeric additives the evidence of suitability shall be furnished prior to the use (contact body: concrete with polymeric additives).
- (4) The determinations of section 4.1 and 4.2 will be complied with.

#### 4.2.4 Control of the execution

- (1) Before, during and after the installation of the joint sealing system the following controls are made:
- (2) Before the installation:
  - For sealing layers made of concrete the strength class of concrete and the water-cement ratio according to EN 206-1 and/or according to the national stipulations of the respective countries (e.g. G: according to the DAfStb Richtlinie "Betonbau im Umgang mit wassergefährdenden Stoffen" ('Concrete construction for handling substances hazardous to water')) shall be proven before placing the joint sealing system on site.
  - Control of the joint width, the joint distance and the depth of the joint's space according to Annex 1 and/or Annex 3, Table 1 respectively, of the design documents e.g. design of the joint (see section 4.2.1) and/or the processing instructions by the manufacturer.
  - Control of the condition of the contact areas (bond areas). Dirt accumulations shall be removed thoroughly before the installation.
  - Determination of the surface temperature and comparison (3 K above thawing temperature) in accordance with section 4.2.2.

(3) After the installation:

- The installed joint sealing system is examined in full length for flank adhesion. This test can be performed with one of the following methods:

- Ball stick test

In doing this, a stick hemispherical at one end of half a joint width will be impressed approx. 2 mm in the joint.

- Pulley test

By using a circular metal disc of roughly 100 mm in diameter, the thickness of which is half as wide as the joint width and where the circumferential surface is semicircular, the impression test will be carried out continuously. For doing that the disc is provided with an axle and installed in a device which will be sufficiently loaded (impress approx. 2 mm deep). The device prepared like this will be pulled slowly over the joint sealing system.

#### 4.3 Responsibilities for the manufacturer

It is the manufacturer's responsibility to make sure that all those who use his joint sealing system will be appropriately informed about the specific conditions according to sections 1, 2, 4, and 5 including the annex to this ETA, the installation and processing instructions by the manufacturer and the not confidential part of the technical documentation to this ETA.

This information can be given by reproduction of the corresponding parts of the European technical approval.

### 5 Indications to the manufacturer

#### 5.1 Packaging, transport and storage

(1) Packaging, transport and storage of the single components of the joint sealing system shall be such that the fitness for the intended use will not be affected. All components of the joint sealing system and the respective primer shall in particular be stored in closed original containers/packs protected against moisture preferably at room temperatures. The maximum storage time indicated on the containers/packs shall be observed.

(2) The components of the joint sealing system shall not be exposed to direct solar radiation. They are to be stored such that the temperature of the material at the time of processing is higher than +10 °C and lower than +40 °C.

(3) The information on requirements from other fields of the law (e.g. law relating to hazardous substances and/or law relating to transport) given on the containers/packs shall be observed.

#### 5.2 Use, maintenance, repair

(1) In order to ensure the fitness for use of the joint sealing system after their installation in the construction works, the measures given in clauses (2) to (6) are recommended. It is the task of the manufacturer to make sure that all parties involved are adequately informed.

(2) The operator of the respective plant establishes operating instructions including, among others, the description of the necessary measures

- for the control of the proper condition
- for ensuring proper operation
- for maintenance and repair

of the joints as well as the description of measures to be taken in case of damage. The inspection intervals are specified according to the stress levels given in Annex 2 in conjunction with Annex 10 of this ETA. The inspection results are documented.

(3) Major dripping losses and/or accumulations of already minor liquid quantities are directly removed.

(4) Leaked out substances hazardous to water will immediately be bound with suitable means. The polluted bonding agent is taken up and recycled duly and without loss or is disposed of. Appropriate materials and/or employment devices are specified in the operating instructions and are constantly ready in sufficient quantity. For the disposal and treatment, respectively, of the materials resulting in waste reference is made to the applicable regulations of the respective Member State (e.g. in G: Kreislaufwirtschafts- und Abfallgesetz ('Act for Promoting Closed Substance Cycle Waste Management and Ensuring Environmentally Compatible Waste Disposal')).

(5) Before the operation of a plant and after repair measures of larger extent start-up inspections are carried out as follows:

- The start-up inspection is carried out by expert personnel only. Further requirements for the individuals can result from national regulations of the Member States.
- The person put in charge of the inspection will constantly be kept informed on the process of the work. The person is given the possibility to participate in the controls of the joint sealing system before and after the installation according to section 4.2.4 and to evaluate the results of the controls.
- Checking the condition of the installed joint sealing systems is done via visual inspection of the surface of all joints of the respective sealing construction.
- The person put in charge of the inspection examines the intended control intervals (according to section 5.2 (2)) of the operating instructions by the operator of the respective plant.

(6) One year after every start-up inspection, then after four years and then every fifth year recurring inspections shall be performed as follows:

- The recurring inspections are carried out by expert individuals. Further requirements for the individuals can result from national regulations of the Member States.
- The investigation of the condition of the joint sealing system is done via visual check of the joint sealing in all areas of the respective sealing construction. Particular attention shall be paid to possible edge spalling in the chamfer area.
- In addition the examination for tightness shall be carried out by audit-testing of the joint sealing system for side wall bonding following section 4.2.4(3) (ball stick or pulley test).
- On the basis of the documentation in accordance with section 5.2 (2) it is checked whether
  - the check intervals were kept,
  - the specifications of the operating instructions are observed, and
  - no longer contact has occurred between the joint sealing compound and the liquids hazardous to water in the course of use.
- If doubts arise about the tightness of the joint sealing system (e.g. due to softening of the surface of the joint sealing compound) further examinations become necessary. For that purpose samples (drilling core) will be taken from the section concerned, if need be. It can be done without the taking of samples from the soil underneath the joint sealing systems, if demonstrably no complete penetration of the joint sealing system occurred by liquids hazardous to water.

(7) Further national regulations of the Member States shall remain unaffected.

## **6 Recommendations for the operator of a plant for storing, filling and handling of water-endangering substances**

(1) Reference is made to the necessity of a permanent surveillance by the operator of the plant for tightness and operability of the joint sealing system in accordance with the requirements of the national regulations of the respective countries.

(2) An operating instruction shall be prepared by the operator of the respective plant which takes the following points into account:

- The contents of the regulations to be applied by the employee working in these fields will be presented in the operating instructions in a comprehensible and clear way and be laid out or put up at a suitable place of the plant. The operating instruction can be part of operating instructions in accordance with other fields of law of the respective Member States.
- The employees working in these fields will be instructed in the possible threats to water when storing, filling and handling substances hazardous to water as well as in the measures of hazard control. Before working in this field, they will be instructed before working with these substances and afterwards at least once per year.
- All essential measures of control by the operator, the maintenance and the repair will be specified in the operating instructions. The realization of the measures will be noted in each case in the company journal.
- In this operating instruction the operator lays down his inspection intervals with regard to the stress level specified in this ETA in accordance with Annex 2 in conjunction with Annex 10. These records are ready and will be presented to the person responsible according to the national regulations in force of the respective country.

(3) The operator of a plant for the storing, filling and handling of substances hazardous to water commissions companies with maintenance and repair of the joint sealing systems according to section 4.2.3 (1) and with the cleaning according to section 4.2.2 (1) and (2).

(4) After each repair work and/or touch up of a larger extent a start-up check will be carried out and the recurring test shall be repeated by the person charged with the test, respectively, in accordance with the effective national regulations of the respective country.

(5) The joint sealing system is driven on only with vehicles supplied with pneumatic tyres.

Uwe Bender  
Head of Department

*beglaubigt:*  
Westphal-Kay

**Joint sealing system,  
Eurolastic TC 30 S, black,  
by  
Euroteam Bauchemie GmbH  
used in plants made of  
- concrete, fibre concrete, polymer-concrete based on UP-resin and uncoated and  
CD-coated <sup>1)</sup> parts made of steel -**

**trafficable joint construction**

**not trafficable joint construction**

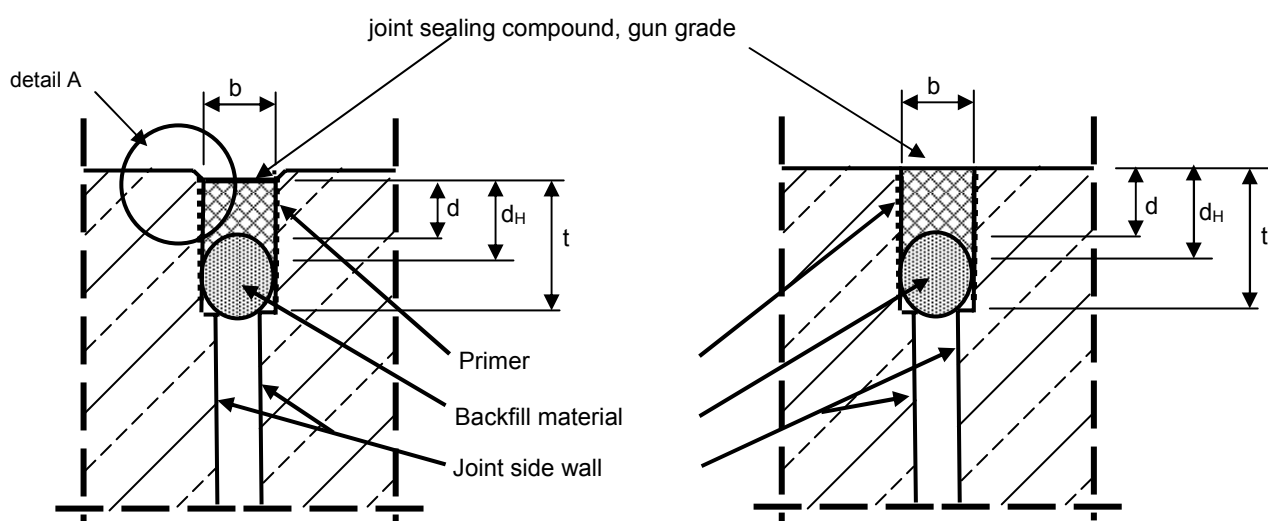

**Detail A:**

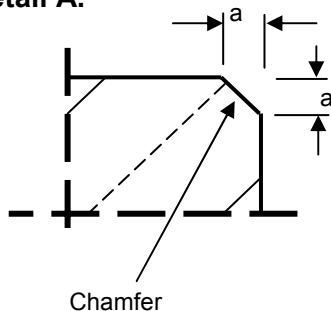

- a** = Chamfer edge (3-5) mm
- b** = Joint width
- d** = Thickness of the joint sealing compound
- d<sub>H</sub>** = Joint sealing compound bonding or contact surface on the joint side wall
- t** = Depth of the joint chamber

<sup>1)</sup> CD-coated steel only permitted with cathodic dip coating (corrosion protection) based on aminated, water-insoluble epoxy resin on bisphenol-A.

Eurolastic TC 30 S, black

Product and built-in state

Annex 1

The joint sealing system used in plants for the containment, handling and filling of substances hazardous to water is impermeable and chemically resistant to the following liquids (stress level: S<sub>1</sub>, H<sub>1</sub>, F<sub>1</sub> "low", S<sub>2</sub>, H<sub>2</sub>, F<sub>2</sub> "medium" and S<sub>3</sub>, F<sub>3</sub> "high", see Annex 10).

**Table 1:** List of liquids for stress level S<sub>1</sub>, H<sub>1</sub> and F<sub>1</sub> "low" <sup>1)</sup>

Group No.	liquids
DF 4	All hydrocarbons and mixtures containing benzene with a maximum of 5 volume percent of benzene, except fuels
DF 4a	Benzene and mixtures containing benzene

<sup>1)</sup> The usability was verified for the test period of **24 hours**.

**Table 2:** List of liquids for stress level S<sub>2</sub>, H<sub>2</sub> and F<sub>2</sub> "medium"

Group No.	liquids
DF 1	Gasoline for spark ignition engines, super and normal (according to EN 228:2004-03) with a maximum of 5 volume percent of bio-alcohol
DF 1a	Gasoline for spark ignition engines, super and normal (according to EN 228:2004-03) with a maximum of 20 volume percent of bio-alcohol
DF 2	Aviation gasoline
DF 3	Fuel EL Unused combustion engine oil Unused motor vehicle gear oil Mixture of saturated and aromatic hydrocarbons with an aromatic content ≤ 20 wt.-% and a flash point > 55 °C
DF 3a	Diesel fuel (according to EN 590) with a maximum of 5 volume percent of bio-diesel fuel
DF 3b	Diesel fuel (according to EN 590) with a maximum of 20 volume percent of bio-diesel fuel
DF 4b	Crude oils
DF 4c	Used internal combustion engine oils and used vehicle gear oils with a point of ignition of > 55 °C
DF 5	Monovalent and polyvalent alcohol (up to a maximum of 48 volume percent of methanol), glycol ethers
DF 5a	alcohol and glycol ethers
DF 5b	Monovalent and polyvalent alcohol ≥ C <sub>2</sub>
DF 7b	bio-diesel fuel
DF 8	Aqueous solutions of aliphatic aldehyde up to 40 %
DF 9	Aqueous solutions of organic acids (carboxylic) up to 10 % as well as their salts in aqueous solutions
DF 10	Mineral acids up to 20 % as well as acidic, hydrolyzed inorganic salts in aqueous solution (pH < 6), except for hydrofluoric acids and acids with an oxidizing effect and their salts
DF 11	Inorganic lye as well as alkaline hydrolysing inorganic salts in aqueous solution (pH > 8), except oxidising salt solutions (e.g. hypochlorite)
DF 12	Aqueous solutions of inorganic non-oxidising salts with a pH value between 6 und 8
DF 13	Amines as well as their salts (in aqueous solutions)
-	Single liquid: Skydrol LD 4 (Solutia Europe S.A./N.V.)

**Table 3:** List of liquids for stress level S<sub>3</sub> and F<sub>3</sub> "high"

Group No.	liquids
-	Single liquid: Urea with max. 35% in aqueous solution

Eurolastic TC 30 S, black

List of liquids

Annex 2

**Table 1:** Dimensions of the joint construction<sup>1), 2)</sup>

Level of trafficability "t1" – trafficable with pneumatic tyres–		
b	d	d <sub>H</sub>
mm		
10	10	15
Intermediate values can be interpolated		
20	20	30

Level of trafficability "t0" – trafficable with pedestrians–		
b	d	d <sub>H</sub>
mm		
10	10	15
Intermediate values can be interpolated		
40	40	60

- 1) compare with Annex 1  
 2) For joints which are only suited for traffic with pedestrians ("t0", according to Annex 4, Table 1), the admissible joint width is max. 40 mm. The other dimensions of the joint construction (d, d<sub>H</sub> and t) are to be adapted according to the table mentioned above.

**Figure 1:** Migration behaviour in the area of the embedded joint sealing system<sup>1)</sup>

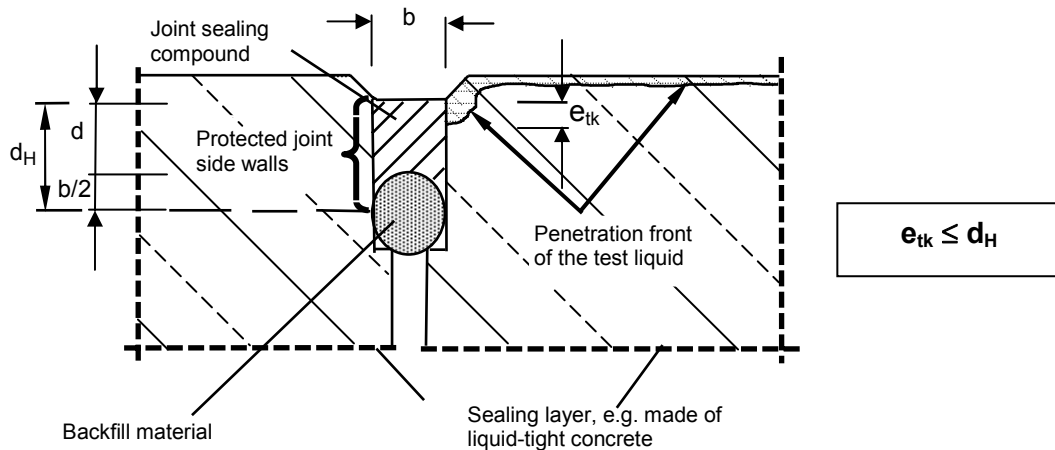

- d<sub>H</sub> = bond area and/or contact surface of the joint sealing compound at the joint side wall; d<sub>H</sub> = d + b/2  
 b = width of the joint sealing compound  
 d = thickness of the joint sealing compound; d = (0.8 to 1.0) x b  
 e<sub>tm</sub> = average penetration depth of the water-endangering liquid  
 e<sub>tk</sub> = characteristic penetration depth of the water-endangering liquid; e<sub>tk</sub> = e<sub>tm</sub> x 1.35

<sup>1)</sup> see also Annex 6, Table 1

Eurolastic TC 30 S, black	Annex 3
Dimensions of the joint construction and migration behaviour	



**Table 1:** Characteristics, levels, classes and characteristic values

No.	Characteristics / level / classes	unit	characteristic values for the joint sealing system facing		
			contact materials according to Annex 5 and 6:		
			– concrete, – fibre concrete	– polymer concrete (UP resin based) <sup>1)</sup>	– steel (uncoated), – CD-coated steel
1	<b>Airing out</b> (at 23°C) of the primer <sup>2)</sup> minimum:	minutes	60	10	120
2	<b>max. storage time</b> <sup>3)</sup> (at 0 - 40°C) sealing compound: component A component B Primer: component A component B	months	6 6 ----- 12 12	6 6 ----- one-component 12	6 6 ----- 12 12
3	<b>Mixing ratio</b> sealing compound: (comp. A : comp. B) primer: (comp. A : comp. B)	parts by weight	10 : 1 ----- 3 : 2	10 : 1 ----- one-component	10 : 1 ----- 3,7 : 1
4	Working life (Pot-life)	minutes	min. 120 (depending on weather)		
5	<b>Minimum cure time</b> until the complete chemical and mechanical design resistance	hours	24-48 (depending on weather)		
6	<b>waiting time</b> until trafficability	hours	24-48 (depending on weather)		
7	<b>shade</b> sealing compound: primer <sup>1)</sup> :	-	black light yellow   colourless   green		
8	<b>Backfill material</b> ----- reaction to fire class according to EN 13501-1	-	according to ETA and to the additional provisions by the manufacturer ----- at least class E		
9	surface temperature of the pavement sealing system in areas of joints during installation	°C K	≥ 5°C und ≤ 40°C, ≥ 3 K above temperature of dew point		
10	reaction-to-fire class of the joint sealing compound together with the respective primer <sup>2)</sup> : class E in accordance with EN 13501-1				
11	Level of trafficability	"t0": suited for traffic with pedestrians only, "t1": suited for traffic with pneumatic tyres only			
12	Class of wear and tear "XM1": permissible stress by vehicles with pneumatic tyres				

1) ≤ 15 percent by weight organic components

2) Primer for:  
concrete and fibre concrete:  
polymer-concrete (UP resin based):  
steel and CD-coated steel (see footnote annex 1):

Eurolastic Primer U12G  
Eurolastic Primer S2  
Eurolastic Primer ZM

3) in original container/ pack

Eurolastic TC 30 S, black

Characteristic values for the material

Annex 4

**Table 1:** Admissible contact materials

No	contact materials	comments
1	sealing constructions made of uncoated and CD-coated steel <sup>1)</sup>	- according to the statutory provisions implementing Directives of the European Community, which include the specific requirements of the building authority as well as the law relating to water and which bear the marking of the European Community (CE marking) and/or
2	sealing constructions made of polymer-concrete on UP resin base <sup>2)</sup> with ≤ 15 percent by weight organic components	- according to national provisions of the respective countries, which also include the specific requirements of the building authority as well as the law relating to water and are marked with the intended conformity marking in accordance with the national provisions of the respective countries.
3	sealing constructions made of concrete <sup>3)</sup> : pre-fabricated elements with and without fibres <sup>4)</sup>	- according to Annex 6, Table 1 and/or
4	sealing constructions made of concrete <sup>5)</sup> : in-situ concrete with and without fibres	- according to the national provisions of the respective countries, which also include the specific requirements of the building authority and the law relating to water and are marked with the intended conformity marking in accordance with the national provisions of the respective countries.

<sup>1)</sup> see Annex 1, footnote 1

<sup>2)</sup> e.g.: polymer-concrete, granted and marked in accordance with an *allgemeine bauaufsichtliche Zulassung* ('national technical approval') (G) for gutters (drains) made of polymer-concrete for the use in plants for the containment, handling and filling of substances hazardous to water

<sup>3)</sup> e.g.: vehicle pre-fabricated load-bearing elements made of liquid tight concrete granted and marked in accordance with an *allgemeine bauaufsichtliche Zulassung* ('national technical approval') (G) for the use in plants for the containment, handling and filling of substances hazardous to water

<sup>4)</sup> e.g.: gutters (drains) made of fibre concrete, granted and marked in accordance with an *allgemeine bauaufsichtliche Zulassung* ('national technical approval') (G) for the use in plants for the containment, handling and filling of substances hazardous to water

<sup>5)</sup> e.g.: liquid tight slabs made of in-situ concrete

Eurolastic TC 30 S, black

Admissible contact materials

Annex 5

**Table 1:** Properties of the contact materials

No	Property	Characteristic value	Requirements (comments)
1	2	3	4
contact materials according to Annex 5, Table 1:			
1	migration behaviour	characteristic penetration depth, "e <sub>tk</sub> "	In accordance with the national requirements of the respective countries the characteristic penetration depth "e <sub>tk</sub> " (e <sub>tk</sub> = e <sub>t,m</sub> × 1.35) of the respective test liquid in the concrete has to be smaller than the joint side wall protected by the joint sealing compound (d <sub>H</sub> ), see also Annex 3; Figure 1.
In addition to concrete according to Annex 5, Table 1, N° 4			
2	concrete strength	compressive strength class, C	≥ C30/37 ≤ C50/60 (EN 206-1, Table 7)
3	tightness	water/cement ratio, w/c	w/c ≤ 0.5 (EN 206-1, Table F.1)
In addition to fibre concrete <sup>1)</sup> according to Annex 5, Table 1, N° 4:			
4	tightness	water/cement ratio, w/c	- w/c < 0,45
5	fibres - kind - content - length	- volume, V length of fibre, l	- glass fibre - (0.5 ≤ V ≤ 5) vol.-% - l ≤ 25 mm

<sup>1)</sup> Only glass fibres may be used, which are marked with the conformity mark foreseen (e.g. in Germany *allgemeine bauaufsichtliche Zulassung* ('national technical approval')) according to national provisions of the respective Member States.

Eurolastic TC 30 S, black

Properties of the contact materials

Annex 6

**Table 1:** Admissible deformation distances for planning and design

No	Characteristic values/Notes	Admissible deformations as a result of extension, compressive strain and shear stress
	horizontal: <sup>2)</sup>	
1	<b>extension and compressive strain</b> and the sum resulting from extension, compressive strain in the area of parallel joint side walls and in the area of Tee and/or cruciform joints	10 mm joint width: 2.5 mm 20 mm joint width: 5.0 mm
	vertical: <sup>2)</sup>	
2	<b>shear</b> in the area of parallel joint side walls and in the area of Tee and cruciform joints	10 mm joint width: 2.5 mm 20 mm joint width: 5.0 mm
	resulting: <sup>1), 2)</sup>	
3	<b>Combination</b> of horizontal and vertical deformation in the area of parallel joint side walls and in the area of Tee and cruciform joints	10 mm joint width: 2.5 mm 20 mm joint width: 5.0 mm
4	The effect of the movement behaviour of the adjacent sealing construction (e.g. as a result of temperature, residual shrinkage or creep (concrete)) on the joint width is to be taken into account.	

<sup>1)</sup> **Simultaneous extension and/or compressive stress and shear:**

Taking account of the real stresses, joint sealing compounds may be used placing more emphasis on the extension and/or compression capacity or on the shear capacity according to the following equation.

$$\frac{X_{DS,p}^2}{X_{DS}^2} + \frac{X_{DS,p}^2}{X_{DS}^2} \leq 1$$

with:

- $X_{DS}$  admissible horizontal deformation
- $X_{DS,p}$  extension distance and/or compressive strain distance to be expected (for planning)
- $X_S$  admissible shear distance
- $X_{S,p}$  shear distance to be expected (for planning)

<sup>2)</sup> Intermediate values are to be interpolated linear.

Eurolastic TC 30 S, black

Admissible deformation distances for planning and design

Annex 7

### Details of trafficable joint constructions for individual contact materials

Figure 1:

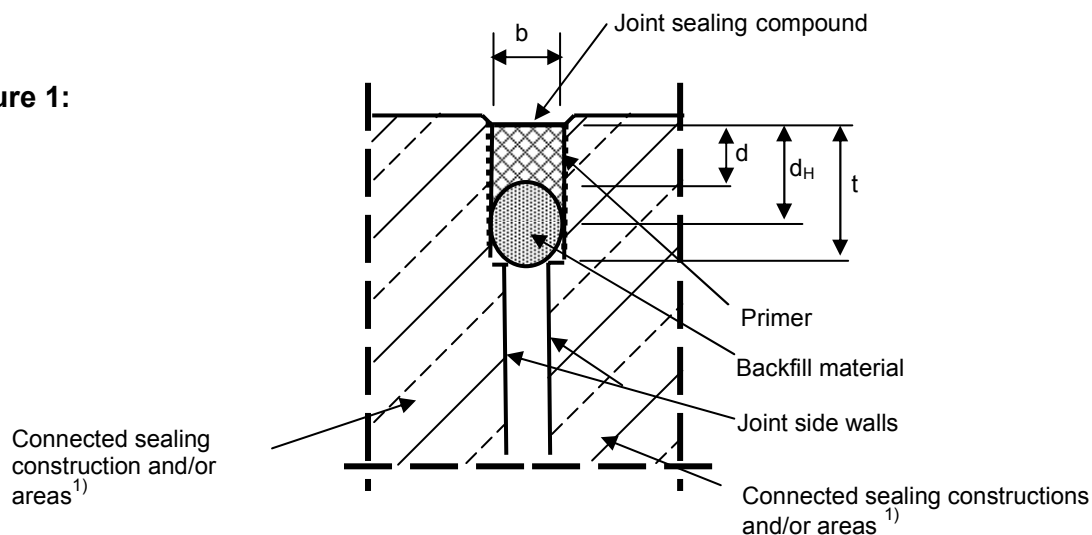

- <sup>1)</sup> admissible contact material:
- concrete
  - fibre concrete
  - polymer concrete (UP resin base)

Figure 2:

steel (coated and CD-coated <sup>1)</sup>)

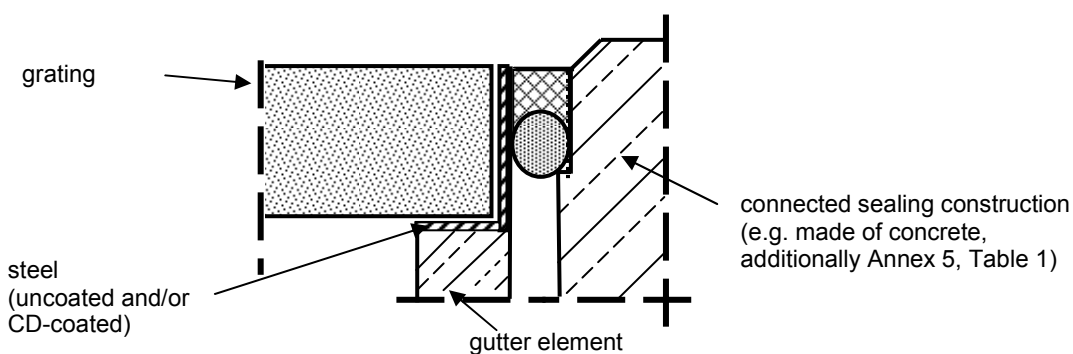

- <sup>1)</sup> CD-coated steel only permitted with cathodic dip coating (corrosion protection) based on aminated, water-insoluble epoxy resin on bisphenol-A.

Eurolastic TC 30 S, black

Examples of trafficable joint construction

Annex 8

No	<b>Confirmation by the executing company</b>	
1.	Project - Name..... - Size .....	
2.	storage substance: .....	
3.	Joint sealing system: <b>Eurolastic TC 30 S, black</b> as a part of the joint sealing system of the Euroteam Bauchemie GmbH used in plants for the containment, handling and filling of substances hazardous to water	
4.	Approval:ETA-10/0270 dated on 08.08.2011	
5.a	Holder of the approval: Euroteam Bauchemie GmbH An der Mühle 1 15345 Altlandsberg Phone: +49 (0) 334 38 / 14 79-0 Fax.: +49 (0) 334 38 / 14 79-29	
5.b	Name of company installing according to ..... ETA section 4.2.2 (1): .....	
5.c	Construction period: .....	
6.	The qualified personnel of the executing company were instructed by the holder of the European technical approval mentioned above in the proper processing.	The qualified personnel of the executing company were instructed by the holder of the European technical approval mentioned above in the proper processing.
7.	<b>Evaluations and controls before and during the installation of the joint sealing system</b>	
	a) Before the installation:	
	- joint width / joint distance / depth of the joint space in mm:	...../...../.....
	- surface temperature / thawing temperature in °C:	...../.....
	- bond areas/contact areas are dry:	yes / no
	- bond areas/contact areas are free from all contaminations:	yes / no
	- system component in accordance with the approval:	yes / no
	- Marking of all components in accordance with the approval:	yes / no
	b) During and after the installation::	
	- Records of the weather conditions are enclosed:	yes / no
	- Visual test: (delete as applicable)	<input type="checkbox"/> no objections <input type="checkbox"/> objections (see comments)
	- side wall adhesion acc. to section 4.2.4(3): (delete as applicable)	<input type="checkbox"/> no objections <input type="checkbox"/> objections (see comments)
	Remarks:	
	Date: .....	Signature / firm stamp
	Eurolastic TC 30 S, black	
	Annex 9	
	Example of a Confirmation by the executing company	

**Stress levels for the effective hourly capacity of substances hazardous to water**

The level of chemical exposure shall be chosen in accordance with the following Tables 5.1 and 5.2. The Tables indicate the time and/or the frequency (period of exposure and frequency, respectively) as well as the appropriate time (test period) during which the test liquid (see list of test liquids) acts on the joint sealing compound (during the test).

The period of exposure shall be chosen by the manufacturer. Following successful performance testing, the characteristic technical values related to the respective stress level shall be specified in the approval.

**Table 5.1:** Stress level related to the period of stress during storage in a test liquid

Stress level 1	Description 2	Period of stress 3	Test period 4
<b>Storage (S)</b>			
<b>S<sub>1</sub></b>	low	up to 8 hours	8 hours
<b>S<sub>2</sub></b>	mean	up to 72 hours	72 hours
<b>S<sub>3</sub></b>	high	up to 3 months	≥ 21 days <sup>1)</sup>

<sup>1)</sup> as far as no change is visible. Otherwise the test period can be prolonged until stability of mass, however up to 42 days at the most.

**Table 5.2:** Stress level related to the frequency of filling and/or handling period of test liquids

Stress level 1	Description 2	Period of stress 3	Test period 4
<b>Handling (H) and Filling (F)</b>			
<b>H<sub>1</sub>, F<sub>1</sub></b>	low	maximum of 4 times per year	8 hours
<b>H<sub>2</sub>, F<sub>2</sub></b>	mean	maximum of 200 times per year	72 hours
<b>F<sub>3</sub></b>	high	more than 200 times per year	≥ 21 days <sup>1)</sup>

<sup>1)</sup> as far as no change is visible. Otherwise the test period can be prolonged until stability of mass, however up to 42 days at the most.

Eurolastic TC 30 S, black	Annex 10
Stress levels	