

## European Technical Approval ETA-11/0164

English translation prepared by DIBt - Original version in German language

Handelsbezeichnung  
*Trade name*

COLLAK TACO QUÍMICO

Zulassungsinhaber  
*Holder of approval*

Collak, S.A.  
C/Francia nº 3, Pol Ind Pla de Llerona  
08520 LES FRANQUESES DEL VALLÈS - BARCELONA  
SPANIEN

Zulassungsgegenstand  
und Verwendungszweck  
*Generic type and use  
of construction product*

Verbunddübel (Injektionssystem) mit Ankerstange in den Größen M10,  
M12 und M16 zur Verankerung im ungerissenen Beton  
*Bonded anchor (Injection system) with anchor rod of sizes M10, M12  
and M16 for use in non-cracked concrete*

Geltungsdauer:  
*Validity:* vom  
*from*  
bis  
*to*

30 May 2011  
5 September 2012

Herstellwerk  
*Manufacturing plant*

Collak S.A. Plant1, Spain

Diese Zulassung umfasst  
*This Approval contains*

13 Seiten einschließlich 5 Anhänge  
*13 pages including 5 annexes*

## I LEGAL BASES AND GENERAL CONDITIONS

- 1 This European technical approval is issued by Deutsches Institut für Bautechnik in accordance with:
  - Council Directive 89/106/EEC of 21 December 1988 on the approximation of laws, regulations and administrative provisions of Member States relating to construction products<sup>1</sup>, modified by Council Directive 93/68/EEC<sup>2</sup> and Regulation (EC) N° 1882/2003 of the European Parliament and of the Council<sup>3</sup>;
  - Gesetz über das In-Verkehr-Bringen von und den freien Warenverkehr mit Bauprodukten zur Umsetzung der Richtlinie 89/106/EWG des Rates vom 21. Dezember 1988 zur Angleichung der Rechts- und Verwaltungsvorschriften der Mitgliedstaaten über Bauprodukte und anderer Rechtsakte der Europäischen Gemeinschaften (Bauproduktengesetz - BauPG) vom 28. April 1998<sup>4</sup>, as amended by law of 31 October 2006<sup>5</sup>;
  - Common Procedural Rules for Requesting, Preparing and the Granting of European technical approvals set out in the Annex to Commission Decision 94/23/EC<sup>6</sup>;
  - Guideline for European technical approval of "Metal anchors for use in concrete - Part 5: Bonded anchors", ETAG 001-05.
- 2 Deutsches Institut für Bautechnik is authorized to check whether the provisions of this European technical approval are met. Checking may take place in the manufacturing plant. Nevertheless, the responsibility for the conformity of the products to the European technical approval and for their fitness for the intended use remains with the holder of the European technical approval.
- 3 This European technical approval is not to be transferred to manufacturers or agents of manufacturers other than those indicated on page 1, or manufacturing plants other than those indicated on page 1 of this European technical approval.
- 4 This European technical approval may be withdrawn by Deutsches Institut für Bautechnik, in particular pursuant to information by the Commission according to Article 5(1) of Council Directive 89/106/EEC.
- 5 Reproduction of this European technical approval including transmission by electronic means shall be in full. However, partial reproduction can be made with the written consent of Deutsches Institut für Bautechnik. In this case partial reproduction has to be designated as such. Texts and drawings of advertising brochures shall not contradict or misuse the European technical approval.
- 6 The European technical approval is issued by the approval body in its official language. This version corresponds fully to the version circulated within EOTA. Translations into other languages have to be designated as such.

<sup>1</sup> Official Journal of the European Communities L 40, 11 February 1989, p. 12  
<sup>2</sup> Official Journal of the European Communities L 220, 30 August 1993, p. 1  
<sup>3</sup> Official Journal of the European Union L 284, 31 October 2003, p. 25  
<sup>4</sup> *Bundesgesetzblatt Teil I* 1998, p. 812  
<sup>5</sup> *Bundesgesetzblatt Teil I* 2006, p. 2407, 2416  
<sup>6</sup> Official Journal of the European Communities L 17, 20 January 1994, p. 34

## II SPECIFIC CONDITIONS OF THE EUROPEAN TECHNICAL APPROVAL

### 1 Definition of the construction product and intended use

#### 1.1 Definition of the product

The COLLAK TACO QUÍMICO is a bonded anchor (injection system) consisting of a mortar cartridge and a threaded anchor rod with hexagon nut and washer of sizes M10, M12 and M16. The steel elements (anchor rod, nut, washer) are made of galvanised steel or stainless steel 1.4401, 1.4404 or 1.4571 respectively.

The anchor rod is placed into a drilled hole filled with injection mortar and is anchored via the bond between anchor rod, chemical mortar and concrete.

An illustration of the product and intended use is given in Annex 1.

#### 1.2 Intended use

The anchor is intended to be used for anchorages for which requirements for mechanical resistance and stability and safety in use in the sense of the Essential Requirements 1 and 4 of Council Directive 89/106 EEC shall be fulfilled and failure of anchorages made with these products would cause risk to human life and/or lead to considerable economic consequences. Safety in case of fire (Essential Requirement 2) is not covered in this European technical approval. The anchor is to be used only for anchorages subject to static or quasi-static loading in reinforced or unreinforced normal weight concrete of strength classes C20/25 at minimum and C50/60 at most according to EN 206:2000-12.

It may be anchored in non-cracked concrete only.

##### Elements made of galvanised steel:

The anchor rod, nut and washer made of zinc plated or hot-dip galvanised steel may only be used in structures subject to dry internal conditions.

##### Elements made of stainless steel 1.4401, 1.4404, 1.4571:

The anchor rod, nut and washer made of stainless steel may be used in structures subject to dry internal conditions and also in structures subject to external atmospheric exposure (including industrial and marine environment), or exposure in permanently damp internal conditions, if no particular aggressive conditions exist. Such particular aggressive conditions are e.g. permanent, alternating immersion in seawater or the splash zone of seawater, chloride atmosphere of indoor swimming pools or atmosphere with extreme chemical pollution (e.g. in desulphurization plants or road tunnels where de-icing materials are used).

The anchor may be installed in dry or wet concrete, it must not be installed in flooded holes.

This European technical approval covers anchoring in hammer drilled holes only.

The anchor may be used in the following temperature range:

Temperature range: -40 °C to +80 °C (max long term temperature +50 °C and max short term temperature +80 °C)

The provisions made in this European technical approval are based on an assumed working life of the anchor of 50 years. The indications given on the working life cannot be interpreted as a guarantee given by the producer, but are to be regarded only as a means for choosing the right products in relation to the expected economically reasonable working life of the works.

## 2 Characteristics of product and methods of verification

### 2.1 Characteristics of product

The anchor corresponds to the drawings and provisions given in Annexes 1 to 3. The characteristic material values, dimensions and tolerances of the anchor not indicated in Annexes 1 to 3 shall correspond to the respective values laid down in the technical documentation<sup>7</sup> of this European technical approval.

The characteristic values for the design of anchorages are given in Annexes 4 and 5.

Each mortar cartridge shall be marked with the imprint "COLLAK TACO QUÍMICO", the size of the cartridge, processing notes, charge code, storage-life, hazard code and curing- and processing time in accordance with Annex 1.

The two components of the injection mortar are delivered in unmixed condition in mortar cartridges of 280 ml, 345 ml or 380 ml according to Annex 1.

### 2.2 Methods of verification

The assessment of fitness of the anchor for the intended use in relation to the requirements for mechanical resistance and stability and safety in use in the sense of the Essential Requirements 1 and 4 has been made in accordance with the "Guideline for European technical approval of Metal Anchors for Use in Concrete", Part 1 "Anchors in general" and Part 5 "Bonded anchors", on the basis of Option 7.

In addition to the specific clauses relating to dangerous substances contained in this European technical approval, there may be other requirements applicable to the products falling within its scope (e.g. transposed European legislation and national laws, regulations and administrative provisions). In order to meet the provisions of the Construction Products Directive, these requirements need also to be complied with, when and where they apply.

## 3 Evaluation and attestation of conformity and CE marking

### 3.1 System of attestation of conformity

According to the decision 96/582/EG of the European Commission<sup>8</sup> the system 2(i) (referred to as System 1) of attestation of conformity applies.

This system of attestation of conformity is defined as follows:

System 1: Certification of the conformity of the product by an approved certification body on the basis of:

(a) Tasks for the manufacturer:

- (1) factory production control;
- (2) further testing of samples taken at the factory by the manufacturer in accordance with a prescribed test plan;

<sup>7</sup> The technical documentation of this European technical approval is deposited at the Deutsches Institut für Bautechnik and, as far as relevant for the tasks of the approved bodies involved in the attestation of conformity procedure, is handed over to the approved bodies.

<sup>8</sup> Official Journal of the European Communities L 254 of 08.10.1996

- (b) Tasks for the approved body:
- (3) initial type-testing of the product;
  - (4) initial inspection of factory and of factory production control;
  - (5) continuous surveillance, assessment and approval of factory production control.

Note: Approved bodies are also referred to as "notified bodies".

## 3.2 Responsibilities

### 3.2.1 Tasks of the manufacturer

#### 3.2.1.1 Factory production control

The manufacturer shall exercise permanent internal control of production. All the elements, requirements and provisions adopted by the manufacturer shall be documented in a systematic manner in the form of written policies and procedures, including records of results performed. This production control system shall insure that the product is in conformity with this European technical approval.

The manufacturer may only use initial/raw/constituent materials stated in the technical documentation of this European technical approval.

The factory production control shall be in accordance with the control plan which is part of the technical documentation of this European technical approval. The control plan is laid down in the context of the factory production control system operated by the manufacturer and deposited at Deutsches Institut für Bautechnik.<sup>9</sup>

The results of factory production control shall be recorded and evaluated in accordance with the provisions of the control plan.

#### 3.2.1.2 Other tasks of manufacturer

The manufacturer shall, on the basis of a contract, involve a body which is approved for the tasks referred to in section 3.1 in the field of anchors in order to undertake the actions laid down in section 3.2.2. For this purpose, the control plan referred to in sections 3.2.1.1 and 3.2.2 shall be handed over by the manufacturer to the approved body involved.

The manufacturer shall make a declaration of conformity, stating that the construction product is in conformity with the provisions of this European technical approval.

### 3.2.2 Tasks of approved bodies

The approved body shall perform the following tasks in accordance with the provisions laid down in the control plan:

- initial type-testing of the product,
- initial inspection of factory and of factory production control,
- continuous surveillance, assessment and approval of factory production control.

The approved body shall retain the essential points of its actions referred to above and state the results obtained and conclusions drawn in a written report.

The approved certification body involved by the manufacturer shall issue an EC certificate of conformity of the product stating the conformity with the provisions of this European technical approval.

<sup>9</sup> The control plan is a confidential part of the European technical approval and only handed over to the approved body involved in the procedure of attestation of conformity. See section 3.2.2.

In cases where the provisions of the European technical approval and its control plan are no longer fulfilled the certification body shall withdraw the certificate of conformity and inform Deutsches Institut für Bautechnik without delay.

### 3.3 CE marking

The CE marking shall be affixed on each packaging of anchors. The letters "CE" shall be followed by the identification number of the approved certification body, where relevant, and be accompanied by the following additional information:

- the name and address of the holder of the approval (legal entity responsible for the manufacturer),
- the last two digits of the year in which the CE marking was affixed,
- the number of the EC certificate of conformity for the product,
- the number of the European technical approval,
- the number of the guideline for European technical approval,
- use category (ETAG 001-1, Option 7),
- size.

## 4 Assumptions under which the fitness of the product for the intended use was favourably assessed

### 4.1 Manufacturing

The European technical approval is issued for the product on the basis of agreed data/information, deposited with Deutsches Institut für Bautechnik, which identifies the product that has been assessed and judged. Changes to the product or production process, which could result in this deposited data/information being incorrect, should be notified to Deutsches Institut für Bautechnik before the changes are introduced. Deutsches Institut für Bautechnik will decide whether or not such changes affect the approval and consequently the validity of the CE marking on the basis of the approval and if so whether further assessment or alterations to the approval shall be necessary.

### 4.2 Design of anchorages

The fitness of the anchor for the intended use is given under the following conditions:

The anchorages are designed in accordance with the "Guideline for European technical approval of Metal Anchors for Use in Concrete", Annex C, Method A, for bonded anchors under the responsibility of an engineer experienced in anchorages and concrete work.

For the verifications given below according to Annex C the following shall be observed:

- For the verification 'concrete cone failure' (clause 5.2.2.4, Annex C of the Guideline)  $N_{Rk,c}$  shall be determined according to (1) and (2): The smaller of the values according to (1) and (2) is decisive.

(1)  $N_{Rk,c}$  according to equation (5.2), Annex C of the Guideline

where:  $N_{Rk,c}^0$  according to Annex 4  
 $S_{cr,N}$  according to Annex 4  
 $G_{cr,N}$  according to Annex 4  
 $\Psi_{ucr,N} = 1,0$

In special cases according to clause 5.2.2.4 g, Annex C of the Guideline the method given there is valid. However, the value  $N_{Rk,c}^0$  shall be calculated according to the following equation:

$$N_{Rk,c}^0 = N_{Rk,c}^0 \text{ (Annex 4)} \times \frac{h'_{ef}}{h_{ef}}$$

(2)  $N_{Rk,c}$  according to equation (5.2), Annex C of the Guideline

where:  $N_{Rk,c}^0 = 0,75 \times 15,5 \times h_{ef}^{1,5} \times f_{ck,cube}^{0,5}$

$S_{cr,N} = 3 h_{ef}$

$C_{cr,N} = 1,5 h_{ef}$

$\Psi_{ucr,N} = 1,0$

- For the verification 'splitting failure due to loading' (clause 5.2.2.6, Annex C of the Guideline)  $N_{Rk,sp}$  shall be determined according to (3).

(3)  $N_{Rk,sp}$  according to equation (5.3), Annex C of the Guideline

where:  $N_{Rk,c}^0$  according to Annex 4

$S_{cr,sp}$  according to Annex 4

$C_{cr,sp}$  according to Annex 4

$\Psi_{ucr,N} = 1,0$

$\Psi_{h,sp} = 1,0$

- For the verification 'concrete pryout failure' (clause 5.2.3.3, Annex C of the Guideline)  $N_{Rk,c}$  for equation (5.6), Annex C of the Guideline, shall be determined according to (1).

Verifiable calculation notes and drawings are prepared taking account of the loads to be anchored.

The position of the anchor is indicated on the design drawings (e.g. position of the anchor relative to reinforcement or to supports, etc.).

### 4.3 Installation of anchors

The fitness for use of the anchor can only be assumed if the anchor is installed as follows:

- anchor installation carried out by appropriately qualified personnel and under the supervision of the person responsible for technical matters of the site,
- threaded rods, washers and hexagon nuts may only be used if the following requirements are fulfilled:
  - Material and mechanical properties of the metal parts according to Annex 2, Table 1,
  - Confirmation of material and mechanical properties of the metal parts by inspection certificate 3.1 according to EN 10204:2004, the documents should be stored,
  - Marking of the threaded rod with the envisage embedment depth. This may be done by the manufacturer of the rod or the person on job site.
- anchor installation in accordance with the manufacturer's specifications and drawings using the tools indicated in the technical documentation of this European technical approval,
- checks before placing the anchor to ensure that the strength class of the concrete in which the anchor is to be placed is in the range given and is not lower than that of the concrete to which the characteristic loads apply,
- check of concrete being well compacted, e.g. without significant voids,
- edge distance and spacing not less than the specified values without minus tolerances,

- positioning of the drill holes without damaging the reinforcement,
- in case of aborted drill hole: the drill hole shall be filled with mortar,
- cleaning the drill hole and setting the anchor in accordance with Annex 3,
- the anchor must not be installed in flooded holes,
- keeping the effective anchorage depth,
- the anchor component installation temperature shall be at least +5 °C,
- the temperature of the concrete during installation and curing of the chemical mortar must not fall below +5 °C,
- in case of overhead installation anchors of size > M12 shall be fixed with wedges,
- the curing time according to Annex 3 shall be observed before the anchor may be loaded,
- after the curing time fixing the member to be anchored by using a calibrated torque wrench by not exceeding the torque moment given in Annex 3.

## 5 Indications to the manufacturer

### 5.1 Responsibility of the manufacturer

The manufacturer is responsible to ensure that the information on the specific conditions according to 1 and 2 including Annexes referred to as well as sections 4.2, 4.3 and 5 is given to those who are concerned. This information may be made by reproduction of the respective parts of the European technical approval. In addition all installation data shall be shown clearly on the package and/or on an enclosed instruction sheet, preferably using illustration(s).

The minimum data required are:

- drill bit diameter,
- hole depth,
- diameter of anchor rod,
- minimum effective anchorage depth,
- information on the installation procedure, including cleaning of the hole with the cleaning equipments, preferably by means of an illustration,
- anchor component installation temperature,
- ambient temperature of the concrete during installation of the anchor,
- admissible processing time (open time) of the mortar,
- curing time until the anchor may be loaded as a function of the ambient temperature in the concrete during installation,
- maximum torque moment,
- identification of the manufacturing batch.

All data shall be presented in a clear and explicit form.

### 5.2 Packaging, transport and storage

The injection cartridges shall be protected against sun radiation and shall be stored according to the manufacture's installation instructions in dry condition at temperatures of at least +5 °C to not more than +25 °C.

Mortar cartridges with expired shelf life must no longer be used.



**Injection mortar "COLLAK TACO QUÍMICO"**

**Coaxial cartridges 280 ml, 380 ml**

**sealing cap**

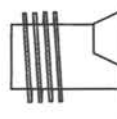
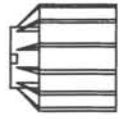

Imprint:  
 Trade name, size, processing notes,  
 charge code, storage life, hazard code,  
 curing- and processing time,

**Side by side cartridge 345 ml**

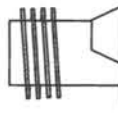
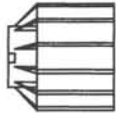

Imprint: see above

**Static mixer**

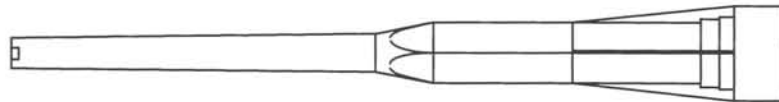

**Anchor rod with washer and hexagon nut**

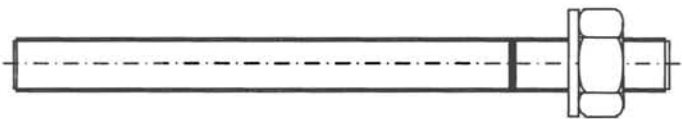

**Installed anchor**

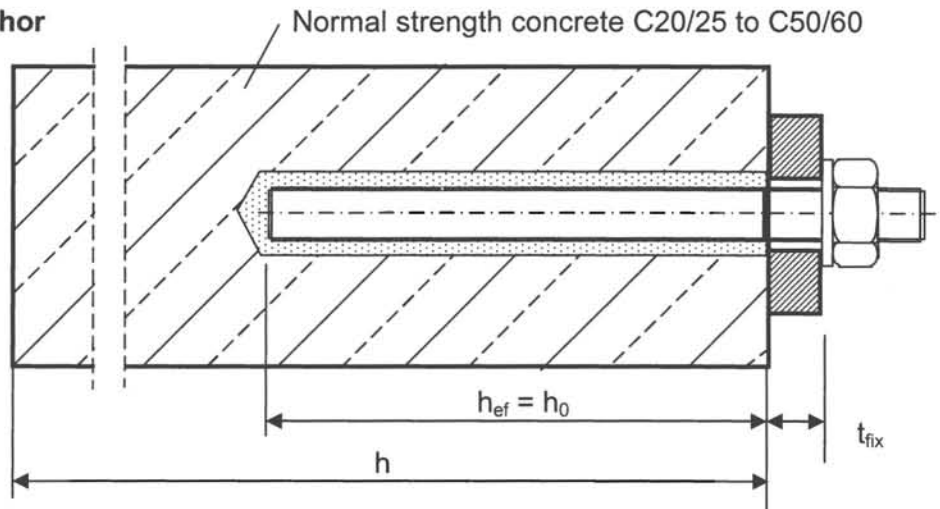

use category: - Installation in dry or wet concrete, not in flooded holes

Temperature range -40°C to +80°C (max. short term temperature +80°C and max. long term temperature +50°C)

**COLLAK TACO QUÍMICO**

**Annex 1**

Product and Intended use

of European technical approval  
**ETA-11/0164**

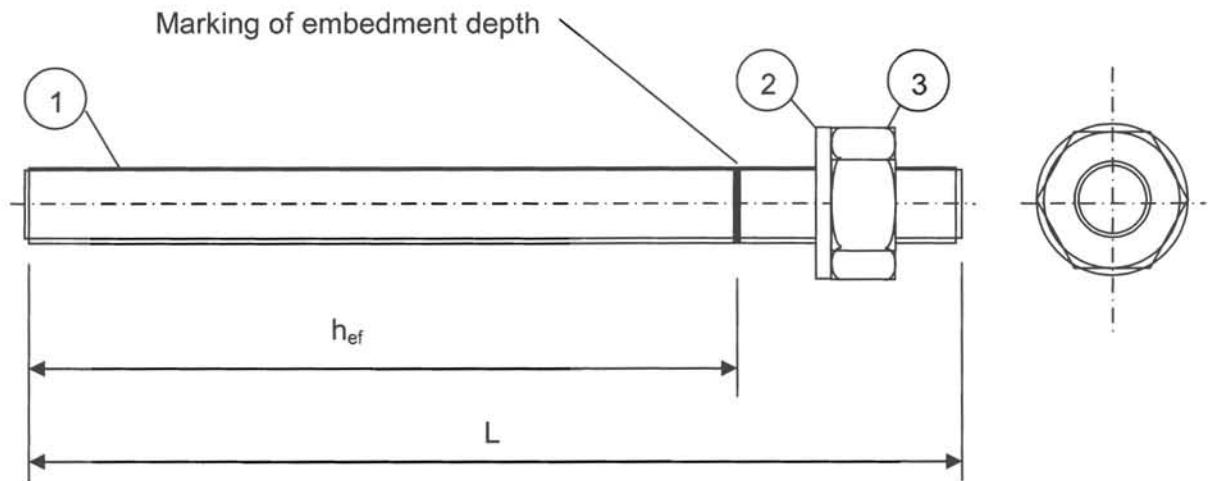

- Commercial standard threaded rod with
- Material and mechanical properties acc. to Table 1
  - Confirmation of material and mechanical properties by inspection certificate 3.1 acc. to EN 10204:2004
  - Marking of the threaded rod with embedding depth

**Table 1 Designation and materials**

Part	Designation	Material
<b>Steel elements made of zinc coated steel</b>		
1	Threaded rod	Steel, galvanised $\geq 5 \mu\text{m}$ acc. to EN ISO 4042:1999 property class 5.8 or 8.8 acc. to EN ISO 898-1:1999
2	Washer EN ISO 887:2000, EN ISO 7089:2000, EN ISO 7094:2000	Steel, galvanised $\geq 5 \mu\text{m}$ acc. to EN ISO 4042:1999
3	Hexagon nut EN ISO 4032:2000	Steel, galvanised $\geq 5 \mu\text{m}$ acc. to EN ISO 4042:1999 property class 5 or 8 acc. to EN 20898-2:1993
<b>Steel elements made of stainless steel</b>		
1	Threaded rod	Stainless steel 1.4401, 1.4404 or 1.4571 property class 70 or 80 acc. to EN ISO 3506:1997
2	Washer EN ISO 887:2000, EN ISO 7089:2000, EN ISO 7094:2000	
3	Hexagon nut EN ISO 4032:2000	

**COLLAK TACO QUÍMICO**

**Annex 2**

Dimensions and materials

of European technical approval  
**ETA-11/0164**

**Table 2 Installation parameter**

Anchor size		M10	M12	M16
Nominal drill hole diameter	$d_0$ [mm]	12	14	18
Depth of drill hole = embedment depth	$h_0 = h_{nom} \geq$ [mm]	90	110	125
Maximum clearance hole in the fixture	$d_f$ [mm]	12	14	18
Diameter of steel brush	$d_b$ [mm]	13.3	14.9	19.35
Torque moment	$T_{inst}$ [Nm]	20	40	80
Minimum thickness of member	$h_{min}$ [mm]	130	160	160
Minimum spacing	$s_{min}$ [mm]	90	110	125
Minimum edge distance	$c_{min}$ [mm]	90	110	125

**Steel brush**

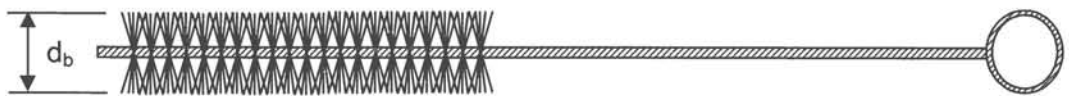

**Installation:**

<p><b>1</b> 2x blowing</p>	<p><b>2</b> 2x brushing</p>	<p><b>3</b> 2x blowing</p>	<p><b>4</b> 2x brushing</p>	<p><b>5</b> 2x blowing</p>
<p><b>6</b> Use appropriate static mixer and dispenser</p>	<p><b>7</b> Discard initial amount of mortar ≈ 10 cm strand</p>	<p><b>8</b> Inject mortar starting from the bottom of the hole</p>	<p><b>9</b> Insert anchor rod up to the embedment mark, the gap must be completely filled with mortar.</p>	<p><b>10</b> Do not touch the anchor rod until the curing time has passed</p>

**Table 3 Minimum curing time**

Concrete temperature	Maximum processing time (minutes)	Minimum curing time in dry concrete (hours)
$\geq +5^\circ\text{C}$	20	6
$\geq +10^\circ\text{C}$	15	4.5
$\geq +20^\circ\text{C}$	7	3
$\geq +30^\circ\text{C}$	4	1.5
$\geq +35^\circ\text{C}$	2	1

If the anchor is set in wet concrete, the curing time shall be doubled

**COLLAK TACO QUÍMICO**

**Annex 3**

Installation parameters and curing time

of European technical approval  
**ETA-11/0164**

**Table 5 Design method A**  
**Characteristic values for tension loads**

Anchor size		M10	M12	M16
<b>Steel failure</b>				
Characteristic resistance	<b>steel 5.8</b> $N_{Rk,s}$ [kN]	29	42	78
Characteristic resistance	<b>steel 8.8</b> $N_{Rk,s}$ [kN]	46	67	126
Respective partial safety factor	$\gamma_{Ms}^{1)}$ [-]	1.5		
Characteristic resistance	<b>steel A4-70</b> $N_{Rk,s}$ [kN]	41	59	110
Respective partial safety factor	$\gamma_{Ms}^{1)}$ [-]	1.87		
Characteristic resistance	<b>steel A4-80</b> $N_{Rk,s}$ [kN]	46	67	126
Respective partial safety factor	$\gamma_{Ms}^{1)}$ [-]	1.6		
<b>Pullout failure and concrete cone failure</b>				
Characteristic resistance in non-cracked concrete C20/25	$N_{Rk,p} = N_{Rk,c}^0$ [kN]	30	40	60
Increasing factor for non-cracked concrete C50/60	$\Psi_c$	1.15	1.07	1.04
Effective anchorage depth	$h_{ef}$ [mm]	90	110	125
Spacing	$s_{cr,N}$ [mm]	180	220	250
Edge distance	$c_{cr,N}$ [mm]	90	110	125
Respective partial safety factor	$\gamma_{Mp} = \gamma_{Mc}^{1)}$ [-]	1.5 <sup>2)</sup>		
<b>Splitting failure</b>				
Spacing	$s_{cr,sp}$ [mm]	4 $h_{ef}$	4 $h_{ef}$	3 $h_{ef}$
Edge distance	$c_{cr,sp}$ [mm]	2 $h_{ef}$	2 $h_{ef}$	1.5 $h_{ef}$
Respective partial safety factor	$\gamma_{Msp}^{1)}$ [-]	1.5 <sup>2)</sup>		

- 1) In absence of other national regulations  
 2) The partial safety factor  $\gamma_2 = 1.0$  is included

**Table 5 Displacements under tension loads**

Anchor size		M10	M12	M16
Tension load	N [kN]	12	19	28
Displacement	$\delta_{N0}$ [mm]	0.8		
Displacement	$\delta_{N\infty}$ [mm]	1.0		

**COLLAK TACO QUÍMICO**

**Annex 4**

Design method A,  
 Characteristic values for tension loads,  
 Displacements

of European technical approval  
**ETA-11/0164**

**Table 6 Design method A**  
**Characteristic values for shear loads**

Anchor size			M10	M12	M16
<b>Steel failure without lever arm</b>					
Characteristic resistance	<b>steel 5.8</b>	$V_{Rk,s}$ [kN]	15	21	39
Characteristic resistance	<b>steel 8.8</b>	$V_{Rk,s}$ [kN]	23	33	63
Respective partial safety factor		$\gamma_{Ms}^{1)}$ [-]	1.25		
Characteristic resistance	<b>steel A4-70</b>	$V_{Rk,s}$ [kN]	20	29	55
Respective partial safety factor		$\gamma_{Ms}^{1)}$ [-]	1.56		
Characteristic resistance	<b>steel A4-80</b>	$V_{Rk,s}$ [kN]	23	34	63
Respective partial safety factor		$\gamma_{Ms}^{1)}$ [-]	1.33		
<b>Steel failure with lever arm</b>					
Characteristic resistance	<b>steel 5.8</b>	$M_{Rk,s}^0$ [Nm]	37	65	166
Characteristic resistance	<b>steel 8.8</b>	$M_{Rk,s}^0$ [Nm]	60	105	266
Respective partial safety factor		$\gamma_{Ms}^{1)}$ [-]	1.25		
Characteristic resistance	<b>steel A4-70</b>	$M_{Rk,s}^0$ [Nm]	52	92	233
Respective partial safety factor		$\gamma_{Ms}^{1)}$ [-]	1.56		
Characteristic resistance	<b>steel A4-80</b>	$M_{Rk,s}^0$ [Nm]	60	105	266
Respective partial safety factor		$\gamma_{Ms}^{1)}$ [-]	1.33		
<b>Concrete pryout failure</b>					
Factor in equation (5.6) of ETAG 001, Annex C, section 5.2.3.3		k [-]	2.0		
Respective partial safety factor		$\gamma_{Mc}^{1)}$ [-]	1.5 <sup>2)</sup>		
<b>Concrete edge failure</b>					
Effective length of the anchor in shear loading		$l_f$ [mm]	90	110	125
Outside diameter of the anchor		$d_{nom}$ [mm]	12	14	16
Respective partial safety factor		$\gamma_{Mc}^{1)}$ [-]	1.5 <sup>2)</sup>		

1) In absence of other national regulations

2) The partial safety factor  $\gamma_2 = 1.0$  is included

**Table 7 Displacements under shear loads**

Anchor size			M10	M12	M16
Shear load		V [kN]	8	12	22
Displacement		$\delta_{V0}$ [mm]	1.0		
Displacement		$\delta_{V\infty}$ [mm]	1.5		

**COLLAK TACO QUÍMICO**

**Annex 5**

Design method A,  
 Characteristic values for shear loads,  
 Displacements

of European technical approval  
**ETA-11/0164**