

European Technical Approval ETA-11/0208

English translation prepared by DIBt - Original version in German language

Handelsbezeichnung <i>Trade name</i>	"ROKU System AWM II"
Zulassungsinhaber <i>Holder of approval</i>	Rolf Kuhn GmbH Jägersgrund 10 57339 Erndtebrück DEUTSCHLAND
Zulassungsgegenstand und Verwendungszweck <i>Generic type and use of construction product</i>	Rohrabschottung <i>Pipe penetration seal</i>
Geltungsdauer: <i>Validity:</i>	vom <i>from</i> bis <i>to</i>
Herstellwerk <i>Manufacturing plant</i>	Rolf Kuhn GmbH Jägersgrund 10 57339 Erndtebrück DEUTSCHLAND

Diese Zulassung umfasst
This Approval contains

28 Seiten einschließlich 19 Anhänge
28 pages including 19 annexes

I LEGAL BASES AND GENERAL CONDITIONS

- 1 This European technical approval is issued by Deutsches Institut für Bautechnik in accordance with:
 - Council Directive 89/106/EEC of 21 December 1988 on the approximation of laws, regulations and administrative provisions of Member States relating to construction products¹, modified by Council Directive 93/68/EEC² and Regulation (EC) N° 1882/2003 of the European Parliament and of the Council³;
 - Gesetz über das In-Verkehr-Bringen von und den freien Warenverkehr mit Bauprodukten zur Umsetzung der Richtlinie 89/106/EWG des Rates vom 21. Dezember 1988 zur Angleichung der Rechts- und Verwaltungsvorschriften der Mitgliedstaaten über Bauprodukte und anderer Rechtsakte der Europäischen Gemeinschaften (Bauproduktengesetz - BauPG) vom 28. April 1998⁴, as amended by law of 31 October 2006⁵;
 - Common Procedural Rules for Requesting, Preparing and the Granting of European technical approvals set out in the Annex to Commission Decision 94/23/EC⁶;
 - Guideline for European technical approval of "Fire Stopping and Fire Sealing Products - Part 2: Penetration Seals", ETAG 026-02.
- 2 Deutsches Institut für Bautechnik is authorized to check whether the provisions of this European technical approval are met. Checking may take place in the manufacturing plant. Nevertheless, the responsibility for the conformity of the products to the European technical approval and for their fitness for the intended use remains with the holder of the European technical approval.
- 3 This European technical approval is not to be transferred to manufacturers or agents of manufacturers other than those indicated on page 1, or manufacturing plants other than those indicated on page 1 of this European technical approval.
- 4 This European technical approval may be withdrawn by Deutsches Institut für Bautechnik, in particular pursuant to information by the Commission according to Article 5(1) of Council Directive 89/106/EEC.
- 5 Reproduction of this European technical approval including transmission by electronic means shall be in full. However, partial reproduction can be made with the written consent of Deutsches Institut für Bautechnik. In this case partial reproduction has to be designated as such. Texts and drawings of advertising brochures shall not contradict or misuse the European technical approval.
- 6 The European technical approval is issued by the approval body in its official language. This version corresponds fully to the version circulated within EOTA. Translations into other languages have to be designated as such.

¹ Official Journal of the European Communities L 40, 11 February 1989, p. 12
² Official Journal of the European Communities L 220, 30 August 1993, p. 1
³ Official Journal of the European Union L 284, 31 October 2003, p. 25
⁴ *Bundesgesetzblatt Teil I 1998*, p. 812
⁵ *Bundesgesetzblatt Teil I 2006*, p. 2407, 2416
⁶ Official Journal of the European Communities L 17, 20 January 1994, p. 34

II SPECIFIC CONDITIONS OF THE EUROPEAN TECHNICAL APPROVAL

1 Definition of the product and intended use

1.1 Definition of the construction product

1.1.1 Description of the pipe penetration seal

The pipe penetration seal called "ROKU® System AWM II" mainly consists of pipe collars and a gap filling material. The pipe penetration seal shall be constructed in accordance with Appendix 3 using the components listed in Appendix 1.

1.1.2 Description of the components of the pipe penetration seal

- The pipe collar, called "AWM II" or "AWM II Light", consists of a housing and an inlay made from the intumescent material "ROKU Strip" according to ETA-10/0117. The housing shall consist of steel sheet and shall be sufficiently protected against corrosion.

The dimensions of the pipe collars, the housings and the inlays shall comply with the information given in Appendix 1.

- For closing joints a non-combustible material (class A1 or A2-s1,d0 according to EN 13501-1) which is dimensionally stable, as e.g. concrete, cementitious or gypsum mortar, shall be used.

1.2 Intended use

1.2.1 General

The pipe penetration seal is used to seal off openings in fire-resistant walls and floors in accordance with section 1.2.2 penetrated by pipes in accordance with section 1.2.3⁷ and serves to preserve the fire resistance of the wall or floor in the vicinity of the penetrations.

Depending on the type of the pipe work the pipe penetration seal reaches a maximum fire resistance class of EI 120-U/U or EI 240-U/C (see also section 2.3).

1.2.2 Building elements

1.2.2.1 The pipe penetration seal may be used in flexible walls, rigid walls and rigid floors. The walls and floors shall be classified according to EN 13501-2 (max. EI 240) in accordance with the fire resistance period required. The walls and floors shall comply with the specifications given in Appendix 2.

1.2.2.2 Depending on the pipe dimensions⁸ and the fire resistance classification required the thickness of the walls shall be at least 100 mm and 300 mm respectively.

Depending on the pipe dimensions⁸ and the fire resistance classification required the thickness of the floor shall be at least 150 mm and 300 mm respectively.

1.2.3 Openings (in the building elements)

1.2.3.1 The opening size is restricted to a size allowing the collar to be fixed to the building element.

1.2.3.2 There shall be a distance of at least 200 mm between the opening to be sealed off and other openings or components. The distance between adjacent penetration seals according to this ETA can be reduced to 100 mm if the openings to be sealed off are not larger than 200 mm x 200 mm.

⁷ The technical provisions of the Member States for the design of piping systems and the reliability of pipe penetrations are not affected by this.

⁸ Outer pipe diameter (d_A) and pipe wall thickness (s)

1.2.4 Installations

- 1.2.4.1 The pipe penetration seal may be used on straight pipes which are fixed perpendicular to the wall or floor surface. The pipes shall consist of the pipe materials listed in Annexes 7 and 8 (depending on the fire resistance class required) and shall have dimensions⁸ according to Annexes 9 to 16 (depending on the installation conditions and the fire resistance class required).
- 1.2.4.2 The pipe work shall only be used for non-combustible liquids and fluids, pneumatic dispatch systems or vacuum cleaning pipes.
The regulations of the Member States shall be observed for more precise specifications of the pipe works (intended use of pipes) for which the penetration seal may be used (e.g. drinking water pipes, heating pipes, waste water pipes)⁹.
- 1.2.5 For the intumescent component of the pipe penetration seal suitability for external use was verified; use category X in accordance with EOTA TR 024.
- 1.2.6 The provisions in this European technical approval are based on an assumed working life of 10 years for the pipe penetration seal "ROKU[®] System AWM II" provided the conditions laid down in sections 4 and 5 relating to manufacturing, installation, use and repair are met. The information provided on the working life cannot be interpreted as a guarantee given by the manufacturer, but should be regarded only as a means for choosing the right products in relation to the expected economically reasonable working life of the construction.

2 Product characteristics and methods of verification

2.1 General

- 2.1.1 The fitness of the pipe penetration seal for the intended use was evaluated in accordance with ETAG 026 Part 2: 2008-01-01.
For the evaluation of the pipe penetration seal, the product properties "reaction to fire", "fire resistance", "emission of dangerous substances" as well as "durability and serviceability" were taken into consideration.
- 2.1.2 The product properties specified in sections 2.2 to 2.5 only apply to the penetration seal and its components described in this ETA. Deutsches Institut für Bautechnik shall be immediately notified of any changes to the materials, composition, dimensions or properties of these components. Deutsches Institut für Bautechnik will then decide if a new evaluation is required.

2.2 Reaction to fire

2.2.1 Casing of the collar

The material for the metal casing is classified according to Commission Decision 96/603/EC (as amended): **Class A1**

2.2.2 Inlay

According to ETA-10/0117 the inlay made from "ROKU[®] Strip" fulfils the requirements for reaction to fire class E according to EN 13501-1.

⁹ The pipe penetration seal may only be fitted to these pipe work types if it fulfils the classification required in the respective country. Particular attention must be paid to the ending of the classification, which reflects the pipe end situation from the fire resistance tests performed to verify the fitness for use (see section 2.3).

2.3 Fire resistance

The pipe penetration seal was tested in accordance with prEN 1366-3: 07/2007 and EN 1366-3: 2009-07. As a maximum, the penetration seal fulfils the requirements of Class EI 120 – U/U or EI 240 – U/C according to EN 13501-2 depending on the pipe dimensions, the intended use of the pipe work (see section 1.2.4.2) and the type of the building element (see Appendices 1 and 2).

In the annexes the maximum fire resistance class verified – under the respective installation conditions and for the respective pipe dimensions – is specified. If installed in walls or floors of the same thickness and density and with the same structure as specified there, but with a lower fire resistance class, the fire resistance class of the pipe penetration seal is reduced to the fire resistance class of the wall or floor.

The fire resistance classes specified in the annexes with the ending -U/U cover the classes of the same fire resistance duration, but with the endings -U/C, -C/U and -C/C. The fire resistance classes with the ending -U/C cover the classes of the same fire resistance duration, but with the ending -C/C.

2.4 Emission of dangerous substances

According to ETA-10/0117 the inlay made from the intumescent material "ROKU[®] Strip" does not contain substances registered as dangerous substances in the list of the European Commission.

Note: In addition to the specific clauses relating to dangerous substances contained in this European technical approval, there may be other requirements applicable to the products falling within its scope (e.g. transposed European legislation and national laws, regulations and administrative provisions). In order to meet the provisions of the Construction Products Directive, these requirements need also to be complied with, when and where they apply.

2.5 Durability and serviceability

According to ETA-10/0117 the inlay made from the intumescent material "ROKU[®] Strip" fulfils the requirements of use category X in accordance with EOTA TR 024. That means that the materials can be exposed to the conditions in interiors with and without moisture loads and external weathering, without expecting significant changes in fire protection characteristics.

Furthermore no significant changes in expansion ratio and expansion pressure of the material were observed after exposure to a constant temperature of 80°C, exposure to permanent wetness (water immersion) and the contact to plastics (PVC, PE) – in each case tested according to EOTA TR 024.

3 Evaluation and attestation of conformity and CE marking

3.1 System of attestation of conformity for the pipe collar

According to Decision 1999/454/EG, amended by Decision 2001/596/EC of the European Commission¹⁰, system 1 of the attestation of conformity applies.

This system of attestation of conformity is defined as follows:

System 1: Certification of the conformity of the product by an approved certification body on the basis of:

(a) Tasks of the manufacturer:

- (1) factory production control;
- (2) further testing of samples taken at the factory by the manufacturer in accordance with a prescribed test plan;

¹⁰ Official Journal of the European Communities 178/52, 14 July 1999

- (b) Tasks of the approved body:
- (3) initial type-testing of the product;
 - (4) initial inspection of the factory and of factory production control;
 - (5) continuous surveillance, assessment and approval of factory production control.

Note: Approved bodies are also referred to as "notified bodies".

3.2 Responsibilities

3.2.1 Tasks of the manufacturer

3.2.1.1 Factory production control

The manufacturer shall exercise permanent internal control of production. All the elements, requirements and provisions adopted by the manufacturer shall be documented in a systematic manner in the form of written policies and procedures, including records of results performed. The factory production control shall ensure that the product is in conformity with this European technical approval.

The manufacturer may only use the initial/raw/constituent materials stated in the technical documentation of this European technical approval.

The factory production control shall be in accordance with the control plan dated 28. June 2011 relating to the European technical approval ETA-11/0208 granted on 22 June 2011, which is part of the technical documentation of this European technical approval. The control plan is laid down in the context of the factory production control system operated by the manufacturer and deposited with Deutsches Institut für Bautechnik.¹¹

The results of factory production control shall be recorded and evaluated in accordance with the provisions of the control plan.

3.2.1.2 Other tasks of the manufacturer

The manufacturer shall provide a technical datasheet and an installation guide containing at least the following information:

Technical data sheet:

1. Field of application:

- Building elements into which the penetration seal may be installed, type and properties of the building elements, such as minimum thickness, density and – in the case of lightweight constructions – the construction requirements.
- Installations that may pass through the penetration seal, type and properties of the installations (including insulation if relevant), such as materials, diameter, thickness; necessary/permitted supports/fastenings; distances.
- Dimensions, minimum thicknesses etc. of the penetration seal
- Climatic conditions covered by the ETA: Internal use with and without moisture loads and external use

2. Construction of the penetration seal including the necessary components and additional products (i.e. gap filling material) with clear indications whether they are generic or specific.

Installation instruction:

- Installation method (e.g. preparation of the supporting structure before installation of the penetration seal)
- The sequence of working steps to be followed

¹¹

The control plan is a confidential part of the European technical approval and only handed over to the approved body involved in the procedure of attestation of conformity. See section 3.2.2.

The manufacturer shall, on the basis of a contract, involve a body which is approved for the tasks referred to in section 3.1 for products in accordance with ETAG 026-2, in order to undertake the actions laid down in section 3.2.2. For this purpose, the control plan referred to in sections 3.2.1.1 and 3.2.2 shall be handed over by the manufacturer to the approved body involved.

The manufacturer shall make a declaration of conformity, stating that the construction product is in conformity with the provisions of the European technical approval ETA-11/0208 issued on 22 June 2011.

3.2.2 Tasks for the approved bodies

The approved bodies shall perform the following tasks in accordance with the provisions laid down in the control plan:

- Initial type-testing of the product
- Initial inspection of factory and factory production control
- Continuous surveillance, assessment and approval of factory production control

The approved bodies shall record the essential points of their actions referred to above and state the results obtained and conclusions made in a written report.

The approved certification body involved by the manufacturer shall issue an EC certificate of conformity of the product stating the conformity with the provisions of this European technical approval.

In cases where the provisions of the European technical approval and its control plan are no longer fulfilled, the certification body shall withdraw the certificate of conformity and inform Deutsches Institut für Bautechnik without delay.

3.3 CE marking

The CE marking shall be affixed on the pipe collar as well as on the packaging or the accompanying commercial documents. The letters "CE" shall be followed by the identification number of the approved certification body and be accompanied by the following additional information:

- the name and address of the manufacturer (legal entity responsible for the manufacture),
- the last two digits of the year in which the CE marking was affixed,
- the number of the EC certificate of conformity for the product,
- the number of the European technical approval,
- the number of the guideline for European technical approval,
- the use category,
- the designation of the product (trade name) (with indication of the size),
- declaration of any dangerous substances or "no dangerous substances",
- "see ETA-11/0208 for other relevant characteristics".

For an example of the CE marking see Appendix 4.

4 Assumptions under which the fitness of the product for the intended use was favourably assessed

4.1 General

4.1.1 It is assumed that

- the penetration seal complies with the specifications in this ETA and the installation was carried out in accordance with this ETA and also in accordance with the technical data sheet and the installation instructions by the manufacturer,
- damages to the penetration seal are repaired accordingly,

- the seal is installed only in the building elements specified in this ETA,
- only installations in accordance with the specifications in this ETA pass through the openings (Parts or service support constructions other than those in accordance with section 1.2 shall not pass through the penetration seal.),
- the installation of the penetration seal does not affect the stability of the adjacent building elements – even in case of fire,
- pneumatic dispatch systems, compressed air systems, etc. are switched off by additional means in case of fire,
- the installations are fixed to the adjacent building elements (not to the seal) in accordance with the relevant regulations in such a way that, in case of fire, no additional mechanical load is imposed on the seal,
- the support of the installations is maintained for the classification period required.

4.1.2 This European technical approval does not address any risks associated with the emission of dangerous liquids or gases caused by failure of the pipe(s) in case of fire nor does it prove the prevention of the transmission of fire through heat transfer via the medium in the pipes.

4.1.3 This European technical approval does not verify the prevention of destruction of adjacent building elements with fire separating function or of the pipes themselves due to distortion forces caused by extreme temperatures. These risks shall be accounted for by taking appropriate measures when designing or installing the pipe work.

The mounting or hanging of the pipes or the layout of the pipe work shall be implemented in such a way that the pipes and the fire-resistant building elements shall remain functional within a period of time which corresponds to the fire resistance period required.

4.1.4 The risk of downward spread of fire caused by burning material which drips through a pipe to floors below, is not considered in this ETA (see EN 1366-3: 2009-07, section 1).

4.1.5 The durability assessment does not take account of the possible effect on the penetration seal of substances permeating through the pipe walls.

4.2 Production

The European technical approval was issued for the product on the basis of agreed data/information, deposited with Deutsches Institut für Bautechnik, which identifies the product that has been assessed and judged. Changes to the product or production process, which could result in this deposited data/information being incorrect, shall be reported to Deutsches Institut für Bautechnik before the changes are introduced. Deutsches Institut für Bautechnik will decide whether or not such changes affect the approval and consequently the validity of the CE marking on the basis of the approval, and if so whether further assessment or alterations to the approval shall be necessary.

4.3 Installation

The product characteristics specified in this European technical approval shall only apply if the penetration seal is installed in accordance with the specifications in Appendix 3 and also with the technical data sheet and the manufacturer's installation instructions.

5 Indications to the manufacturer

5.1 Packaging, transport and storage

5.1.1 The manufacturer's specifications for packaging, transport and storage shall be observed.

5.1.2 The packaging of the pipe collar shall contain the following information:

- Trade name or trademark or other symbol identifying the product
- The date of manufacture (day, month, year or coded information)

5.1.3 The pipe collar shall be packaged for delivery in compliance with the usual delivery conditions and providing sufficient protection against the effects of normal handling.

5.2 Use, maintenance, repair

In general, no maintenance work is necessary. Repair can be performed by replacing damaged collars and/or by renewing damaged gap seals in accordance with Appendix 3.

Prof. Gunter Hoppe
Head of Department

beglaubigt:
Meske-Dallal

English translation prepared by DIBt

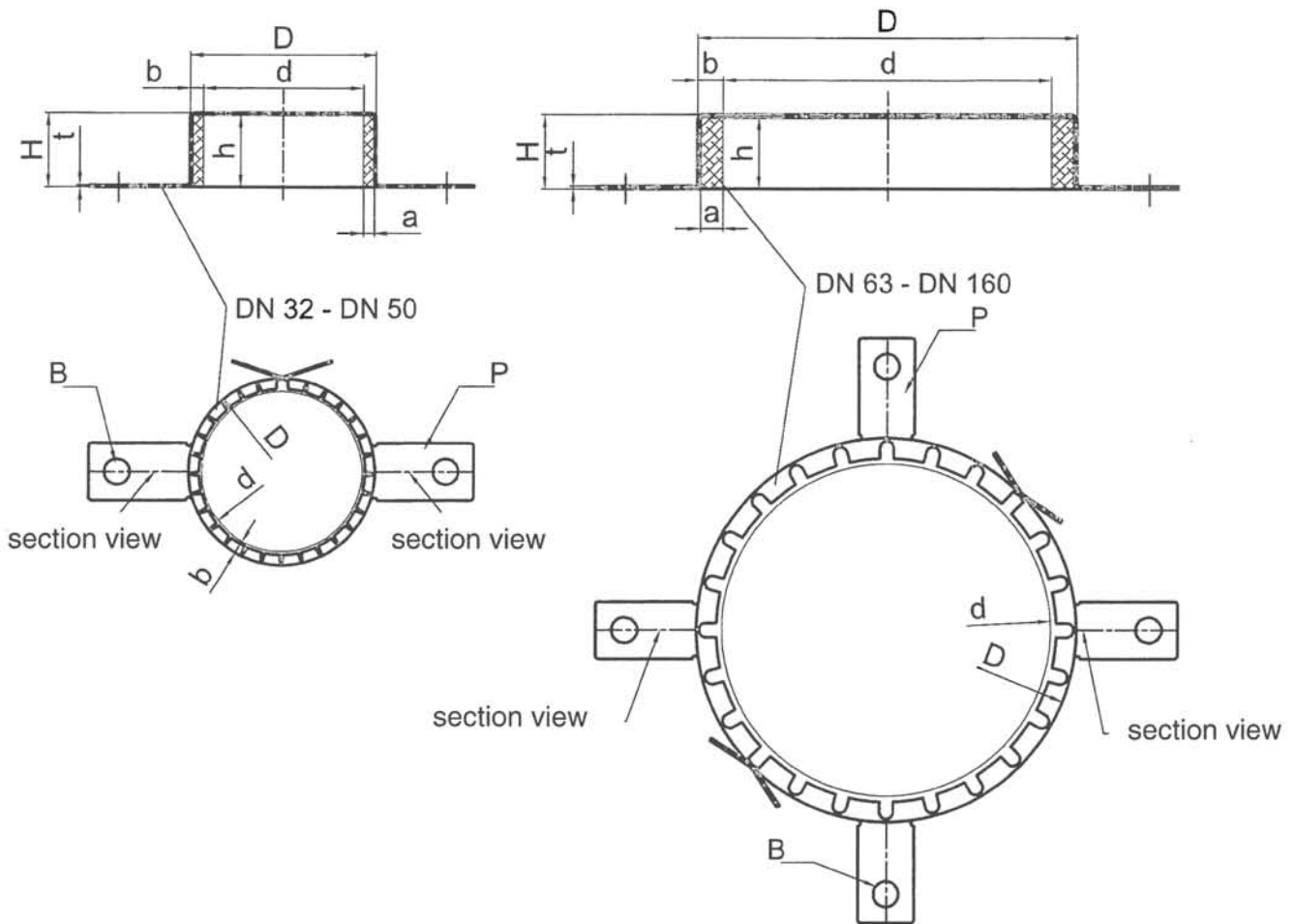

pipe collar "AWM II Light"

dA [mm]	d [mm]	D [mm]	b [mm]	t [mm]	H [mm]	P [Stck]	h [mm]	a [mm]	B [mm]
32	38	47	4,6	0,6	26,0	2	25,0	4,0 -0/+0,8	9,0
40	46	55	4,6	0,6	26,0	2	25,0	4,0 -0/+0,8	9,0
50	56	65	4,6	0,6	26,0	2	25,0	4,0 -0/+0,8	9,0
63	69	82	6,6	0,6	26,0	4	25,4	6,0 -0/+1,0	9,0
75	81	94	6,6	0,6	26,0	4	25,4	6,0 -0/+1,0	9,0
90	96	114	9,0	1,0	26,6	4	25,4	8,0 -0/+1,5	9,0
110	116	134	9,0	1,0	26,6	4	25,4	8,0 -0/+1,5	9,0
125	132	150	9,0	1,0	26,6	4	38,0	10 -0/+2,0	9,0
140	144	168	12	1,0	40,0	4	38,0	10 -0/+2,0	9,0
160	164	188	12	1,0	40	4	38,0	10 -0/+2,0	9,0

"ROKU System AWM II"

APPENDIX 1 – DESCRIPTION OF THE PRODUCT

Design of the pipe collar "AWM II Light" – collar sizes DN 32 to DN 160

Annex 1

English translation prepared by DIBt

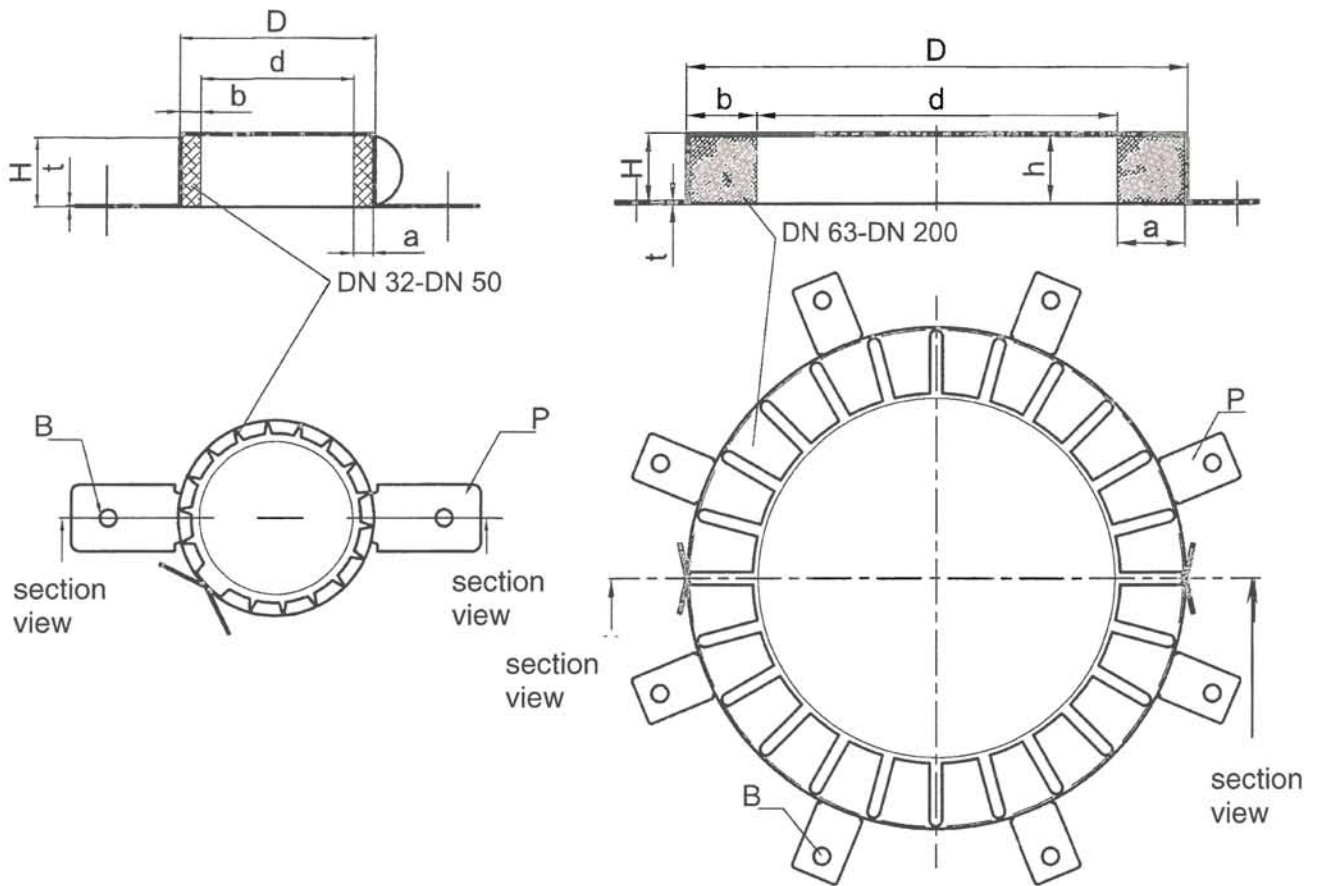

pipe collar "AWM II"

dA [mm]	d [mm]	D [mm]	b [mm]	t [mm]	H [mm]	P [Stck]	h [mm]	a [mm]	B [mm]
32	36	50	7,0	0,6	26,0	2	25,4	6,4 $\pm 0,5$	6,0
40	44	58	7,0	0,6	26,0	2	25,4	6,4 $\pm 0,5$	6,0
50	54	68	7,0	0,6	26,0	2	25,4	6,4 $\pm 0,5$	6,0
63	67	94	13,5	0,6	26,0	4	25,4	12,8 $\pm 1,0$	6,0
75	79	106	13,5	0,6	26,0	4	25,4	12,8 $\pm 1,0$	6,0
90	94	132	18,3	1,1	26,6	4	25,4	17,1 $\pm 1,0$	9,0
110	114	155	20,5	1,1	26,6	4	25,4	19,2 $\pm 1,5$	9,0
125	129	172	20,5	1,1	40,0	4	38,1	19,2 -0/+1,5	9,0
140	144	200	28,0	1,1	40,0	4	38,1	25,6 -0/+2,0	9,0
160	164	220	28,0	1,1	40,0	4	38,1	25,6 -0/+2,0	9,0
180	184	264	40,0	1,5	40,0	8	38,1	38,4 $\pm 3,0$	9,0
200	204	284	40,0	1,5	40,0	8	38,1	38,4 $\pm 3,0$	9,0

"ROKU System AWM II"

APPENDIX 1 – DESCRIPTION OF THE PRODUCT

Design of the pipe collar "AWM II" – collar sizes DN 32 to DN 200

Annex 2

English translation prepared by DIBt

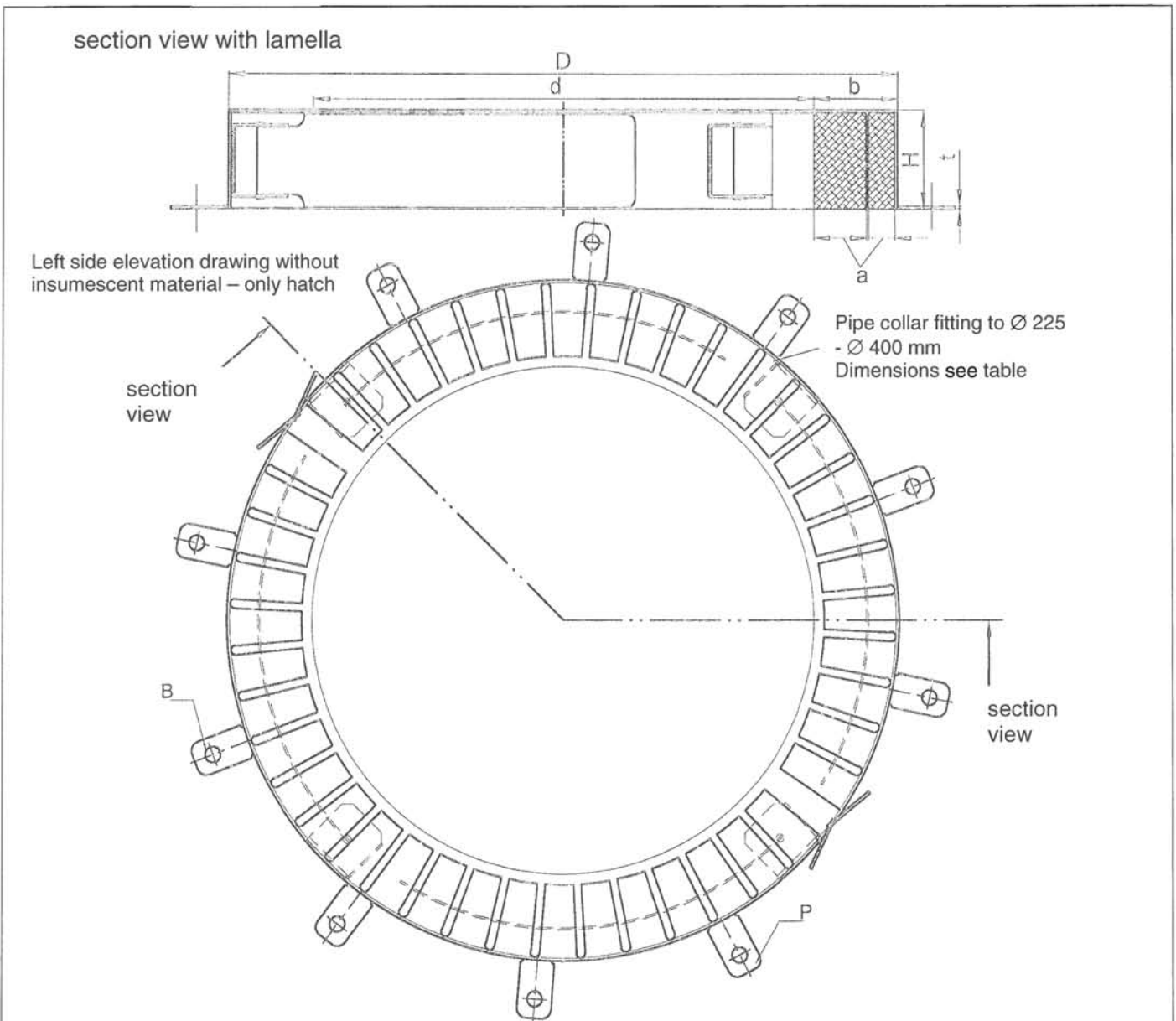

pipe collar "AWM II"

dA [mm]	d [mm]	D [mm]	b [mm]	t [mm]	H [mm]	P [Stck]	h [mm]	a [mm]	B [mm]
225	239	328	44,5	1,5 / 1,0	51,5	10	50	42,0 ± 3,0	8,0
250	264	353	44,5	1,5 / 1,0	51,5	10	50	42,0 ± 3,0	8,0
280	289	378	44,5	1,5 / 1,0	51,5	12	50	42,0 ± 3,0	8,0
300	314	403	44,5	1,5 / 1,0	51,5	12	50	42,0 ± 3,0	8,0
315	328	417	44,5	1,5 / 1,0	51,5	12	50	42,0 ± 3,0	8,0
355	370	459	44,5	1,5 / 1,0	51,5	12	50	42,0 ± 3,0	8,0
400	415	504	44,5	1,5 / 1,0	51,5	12	50	42,0 ± 3,0	8,0

"ROKU System AWM II"

APPENDIX 1 – DESCRIPTION OF THE PRODUCT

Design of the pipe collar "AWM II" – collar sizes DN 225 to DN 400

Annex 3

English translation prepared by DIBt

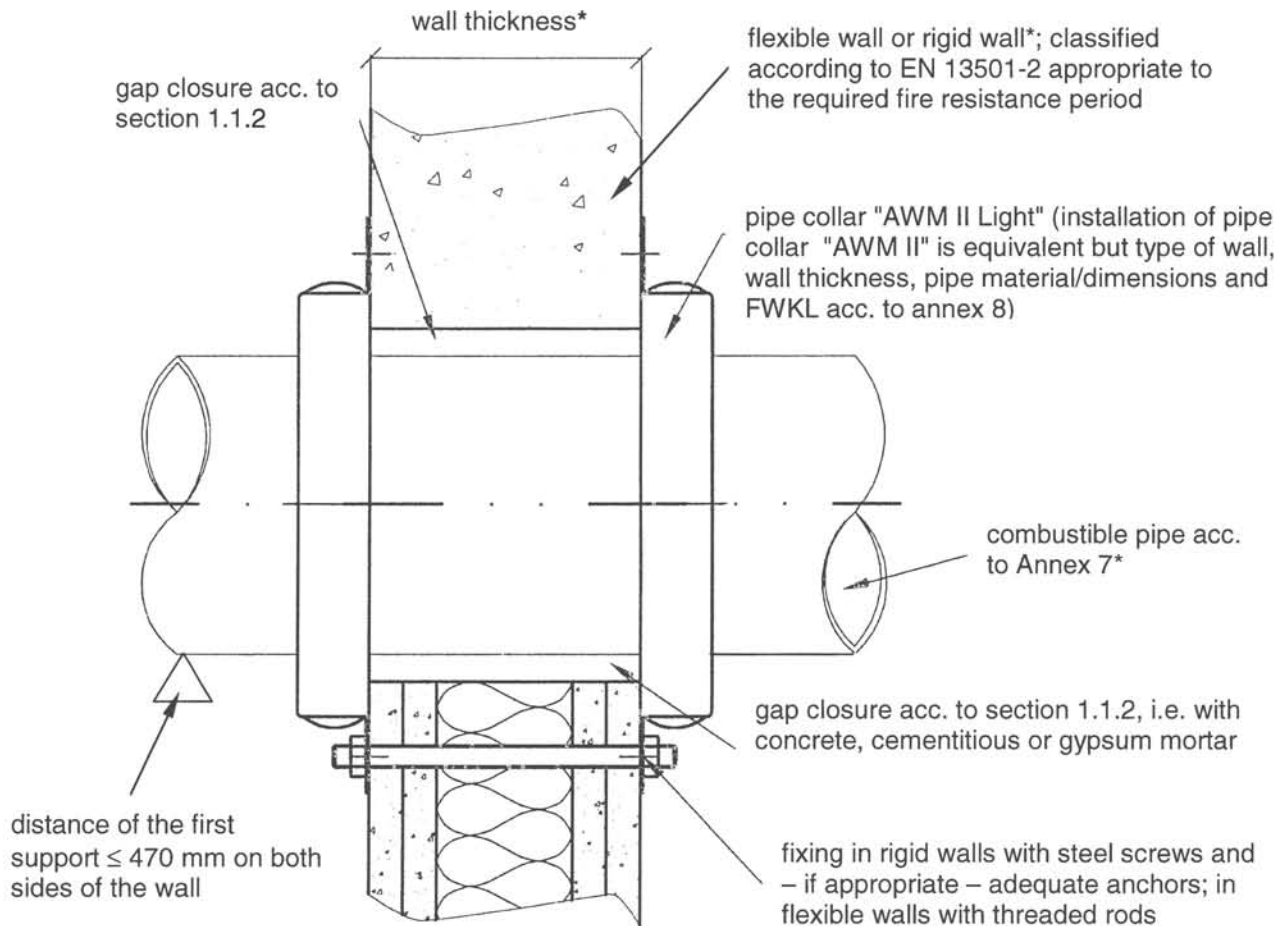

table 1:

type of wall	wall thickness d_w	pipe diameter d_A	FWKL
LTW, MW	≥ 100	≤ 110	EI 120 – U/U
LTW, MW	≥ 100	≤ 160	EI 120 – U/C
MW	≥ 100	≤ 200	EI 240 – U/C
MW	≥ 300	≤ 400	EI 240 – U/C

* Typ and thickness of the wall and related pipe materials and pipe dimensions (outer pipe diameter and pipe wall thickness) see table 1 and Appendix 2.

LTW: flexible wall according to Annex 6

MW: rigid wall according to Annex 6

FWKL: maximum fire resistance class; If installed in walls of the same thickness, density and with the same structure, but with a lower fire resistance class, the fire resistance class of the pipe penetration seal is reduced to the fire resistance class of the wall.

"ROKU System AWM II"

APPENDIX 1 – DESCRIPTION OF THE PRODUCT

Design of the pipe penetration seal – installation into walls

Annex 4

English translation prepared by DIBt

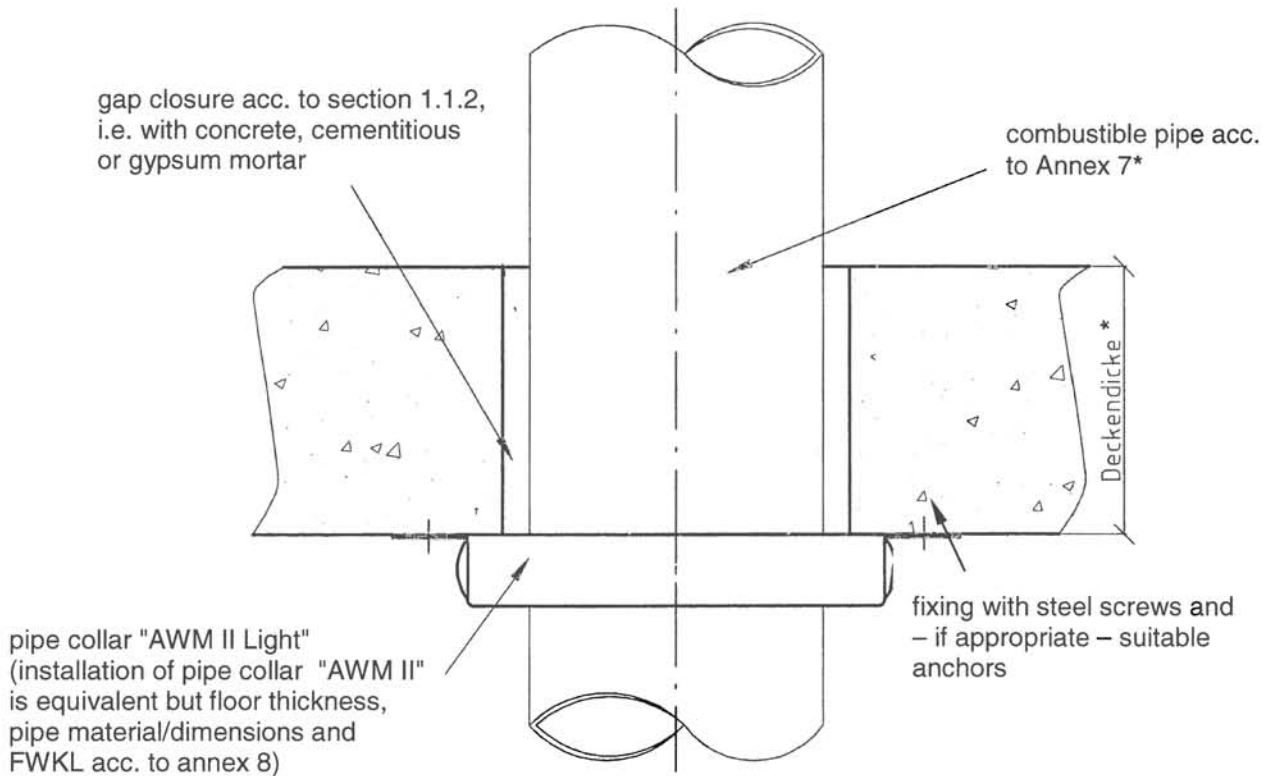

table 2:

Floor thickness d_D	Pipe diameter d_A	Pipe material	FWKL
≥ 150	≤ 50	PVC, PE	EI 120 – U/U
≥ 150	≤ 200	PVC, PE, PP	EI 120 – U/C
≥ 300	≤ 400	PVC, PE, PP	s. Appendix 2

* Thickness of the floor and related pipe materials and pipe dimensions (outer pipe diameter and pipe wall thickness) see table 2 and appendix 2.

FWKL: maximum fire resistance class; If installed in floors of the same thickness, density and with the same structure, but with a lower fire resistance class, the fire resistance class of the pipe penetration seal is reduced to the fire resistance class of the floor.

"ROKU System AWM II"

APPENDIX 1 – DESCRIPTION OF THE PRODUCT

Design of the pipe penetration seal – installation into walls

Annex 5

English translation prepared by DIBt

The pipe penetration seal may be used in

Rigid walls (MW)

- of masonry, concrete, reinforced concrete or aerated concrete
- density $\geq 630 \text{ kg/m}^3$
- thickness $\geq 100 \text{ mm}$ or $\geq 300 \text{ mm}$ (depending on the pipe dimensions and the required fire resistance class; s. Appendices 1 and 2)
- The walls shall be classified according to EN 13501-2 (maximum EI 240) corresponding to the required fire resistance period.

Flexible walls (LTW)

- flexible walls with a steel stud substructure and a lining on both sides made from min. 2 layers of 12,5 mm thick cementitious or gypsum based slabs with a fire reaction class A1 or A2 according to EN 13501-1
- flexible walls with a wood stud substructure and a lining on both sides made from min. 2 layers of 12,5 mm thick cementitious or gypsum based slabs with a fire reaction class A1 or A2 according to EN 13501-1

The distance between the wood substructure and the seal shall be $\geq 100 \text{ mm}$ and the cavity between the linings of the wall, the wood substructure and the seal shall be tightly clogged with mineral wool of fire reaction class A1 or A2 according to EN 13501-1 in a depth of minimum 100 mm.

- thickness $\geq 100 \text{ mm}$
- The walls shall be classified according to EN 13501-2 (maximum EI 120) corresponding to the required fire resistance period.

Rigid floors (D)

- of masonry, concrete, reinforced concrete or aerated concrete
- density $\geq 630 \text{ kg/m}^3$
- thickness $\geq 150 \text{ mm}$ or $\geq 300 \text{ mm}$ (depending on the pipe dimensions and the required fire resistance class; s. appendixes 1 and 2)
- The floors shall be classified according to EN 13501-2 (maximum EI 120) corresponding to the required fire resistance period.

note: This ETA do not cover the installation of the seal in special walls, i.e. in sandwich panel constructions.

"ROKU System AWM II"

APPENDIX 2 – FIELD OF APPLICATION
walls and floors

Annex 6

English translation prepared by DIBt

Pipe group A

Pipes made from PVC-U according to EN 1452-1 and also to DIN 8061/8062

Building element	Thickness d_w or d_D	Fire resistance classification (FWKL)		
		EI 120 – U/U	EI 120 – U/C	EI 240 – U/C
LTW, MW	≥ 100 mm	s. figure 1	s. figure 2	-
MW	≥ 100 mm	s. figure 1	s. figure 3	s. figure 4
MW	≥ 300 mm	s. figure 1	s. figure 5	s. figure 4 and $d_A=220-400$ mm; $s = 11,7$
D	≥ 150 mm	$d_A \leq 50$ mm; $s = 1,8 - 5,6$ mm	s. figure 6	-
D	≥ 300 mm	$d_A \leq 50$ mm; $s = 1,8 - 5,6$ mm	s. figure 7	-

Pipe group B

Pipes made from PE-HD according to EN 1519-1 and also to DIN 8074/8075

Building element	Thickness d_w or d_D	Fire resistance classification (FWKL)		
		EI 120 – U/U	EI 120 – U/C	EI 240 – U/C
LTW, MW	≥ 100 mm	-	s. figure 8	-
MW	≥ 100 mm	-	s. figure 9	$d_A=180-200$ mm; $s = 4,9$
MW	≥ 300 mm	-	s. figure 10	-
D	≥ 150 mm	$d_A \leq 50$ mm; $s = 1,8 - 4,6$ mm	s. figure 11	-
D	≥ 300 mm	$d_A \leq 50$ mm; $s = 1,8 - 4,6$ mm	s. figure 12	-

Pipe group C

Pipes made from PP according to EN 1451-1 and also to DIN 8077

Building element	Thickness d_w or d_D	Fire resistance classification (FWKL)		
		EI 120 – U/U	EI 120 – U/C	EI 240 – U/C
LTW, MW	≥ 100 mm	-	s. figure 13	-
MW	≥ 100 mm	-	s. figure 14	$d_A=180-200$ mm; $s = 4,9$
D	≥ 150 mm	-	s. figure 15	-
D	≥ 300 mm	-	s. figure 16	-

"ROKU System AWM II"

APPENDIX 2 – FIELD OF APPLICATION

Overview of services (installations) – Pipe groups A, B and C

Annex 7

English translation prepared by DIBt

Pipe group D (only for pipe collar "AWM II")

"CoolFit"-Pipes, which are constructed from a smaller pipe made from ABS and a larger pipe made from PE-HD with a filling of ABS (density > 45 kg/m³) in between; produced by Georg Fischer GmbH, 73095 Albershausen; production level 2009.

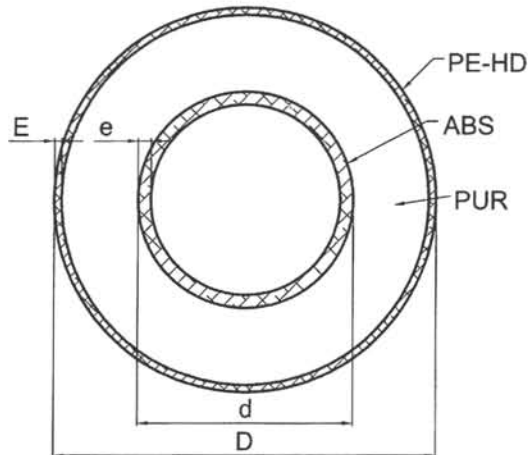

d = Outer diameter ABS pipe
D = Outer diameter PE-HD pipe
e = pipe wall thickness of ABS pipe
E = pipe wall thickness of PE-HD pipe
G = weight of PUR + ABS

D [mm]	E [mm]	d [mm]	e [mm]	G [kg/m]	Building element	Thickness d _w or d _D	FWKL
90	2,2	25	2,3	1,24	LTW, MW	≥ 100 mm	EI 120-U/C
					D	≥ 150 mm	
90	2,2	32	1,9	1,29	LTW, MW	≥ 100 mm	EI 120-U/C
					D	≥ 150 mm	
110	2,7	40	2,4	1,76	LTW, MW	≥ 100 mm	EI 120-U/C
					D	≥ 150 mm	
110	2,7	50	3,0	1,89	LTW, MW	≥ 100 mm	EI 120-U/C
					D	≥ 150 mm	
125	3,0	63	3,8	2,48	LTW, MW	≥ 100 mm	EI 120-U/C
					D	≥ 150 mm	
140	3,0	75	4,6	3,17	LTW, MW	≥ 100 mm	EI 120-U/C
					D	≥ 150 mm	EI 90-U/C
160	3,0	90	5,4	4,11	LTW, MW	≥ 100 mm	EI 120-U/C
					D	≥ 150 mm	EI 90-U/C
180	3,0	110	6,6	5,22	LTW, MW	≥ 100 mm	EI 120-U/C
					D	≥ 150 mm	EI 90-U/C
225	3,2	140	9,2	8,16	MW	≥ 240 mm	EI 120-U/C
					D	≥ 200 mm	EI 90-U/C
250	3,9	160	10,5	10,34	MW	≥ 240 mm	EI 120-U/C
					D	≥ 200 mm	EI 90-U/C
280	4,4	200	13,1	13,42	MW	≥ 240 mm	EI 90-U/C
					D	≥ 200 mm	
315	4,9	225	14,8	17,97	MW	≥ 240 mm	EI 90-U/C
					D	≥ 200 mm	EI 120-U/C

"ROKU System AWM II"

APPENDIX 2 – FIELD OF APPLICATION

Overview of services (installations) – Pipe group D (only for pipe collar "AWM II")

Annex 8

English translation prepared by DIBt

figure 1: Pipes according to pipe group A (PVC): Installation in flexible walls and rigid walls; $d_w \geq 100$ mm; Fire resistance class EI 120-U/U

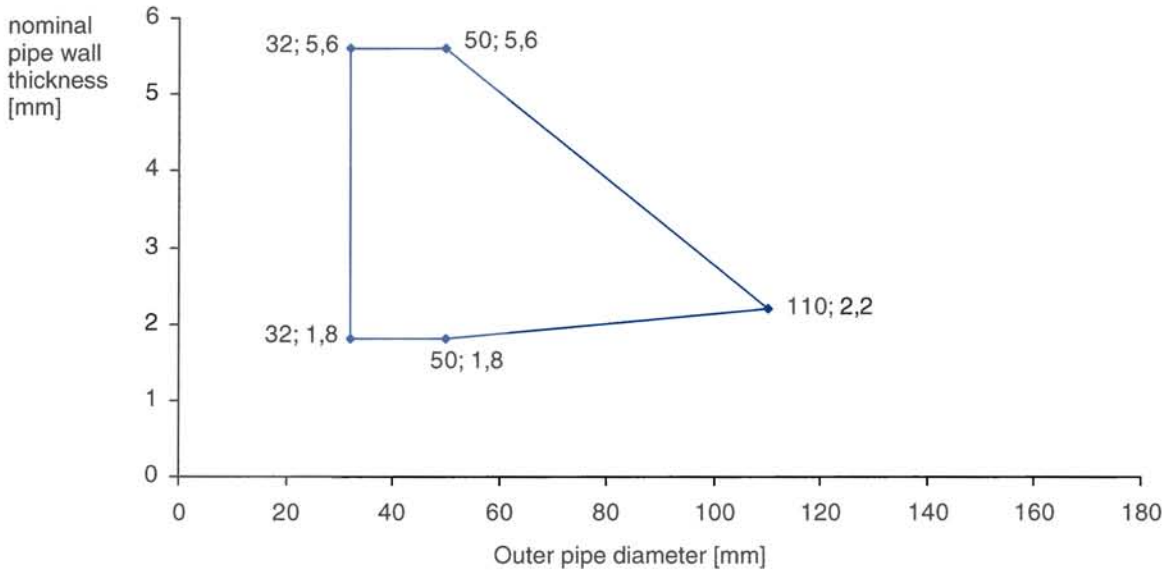
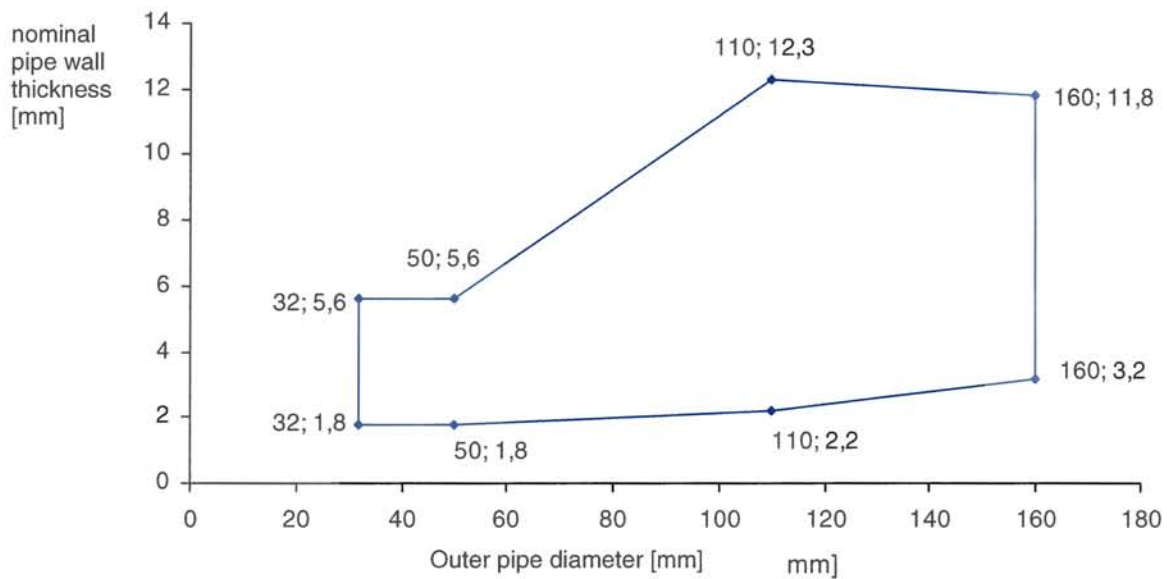

figure 2: Pipes according to pipe group A (PVC): Installation in flexible walls; $d_w \geq 100$ mm; Fire resistance class EI 120-U/C



"ROKU System AWM II"

APPENDIX 2 – FIELD OF APPLICATION
Pipe dimensions for pipes of pipe group A ("PVC")

Annex 9

English translation prepared by DIBt

figure 3: Pipes according to pipe group A (PVC): Installation in rigid walls; $d_w \geq 100$ mm; Fire resistance class 120-U/C

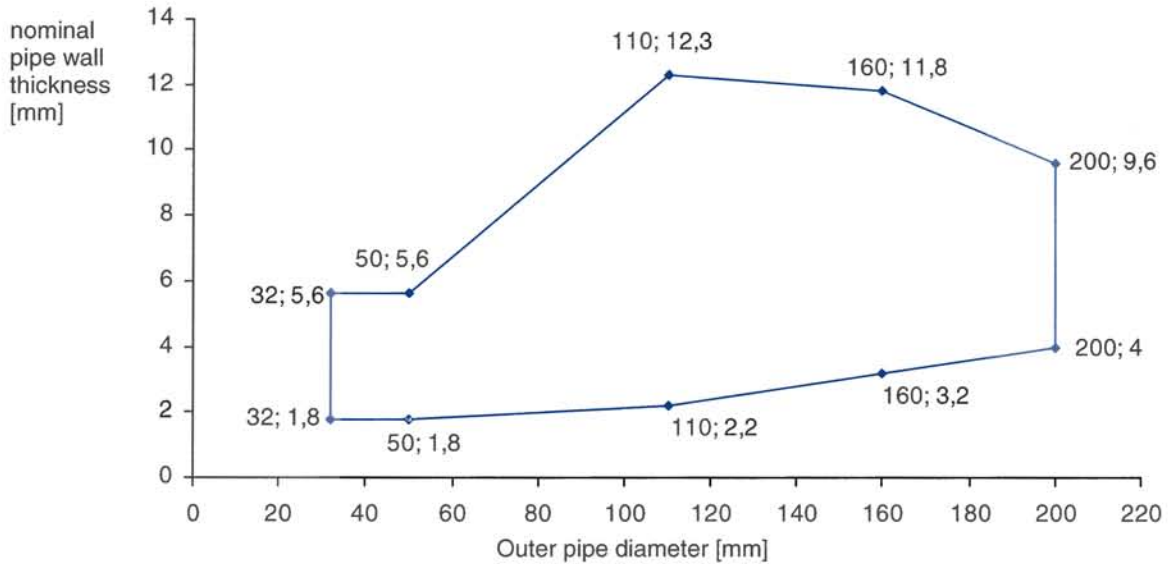
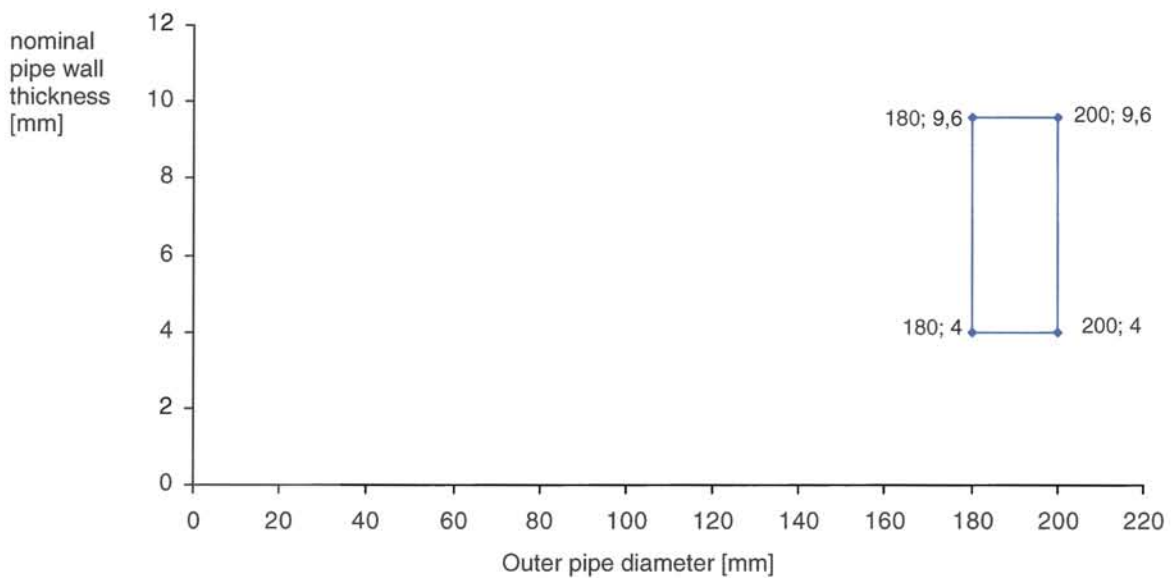

figure 4: Pipes according to pipe group A (PVC): Installation rigid walls; $d_w \geq 100$ mm; Fire resistance class 240-U/C



"ROKU System AWM II"

APPENDIX 2 – FIELD OF APPLICATION
Pipe dimensions for pipes of pipe group A ("PVC")

Annex 10

English translation prepared by DIBt

Figure 5: Pipes according to pipe group A (PVC): Installation in rigid walls; $d_w \geq 300$ mm; Fire resistance class 120-U/C

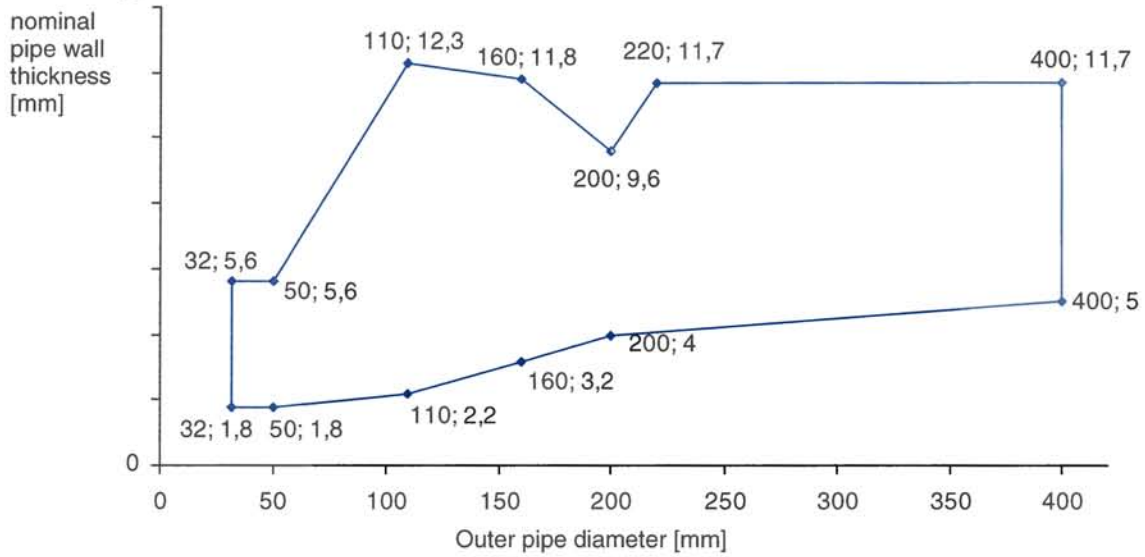
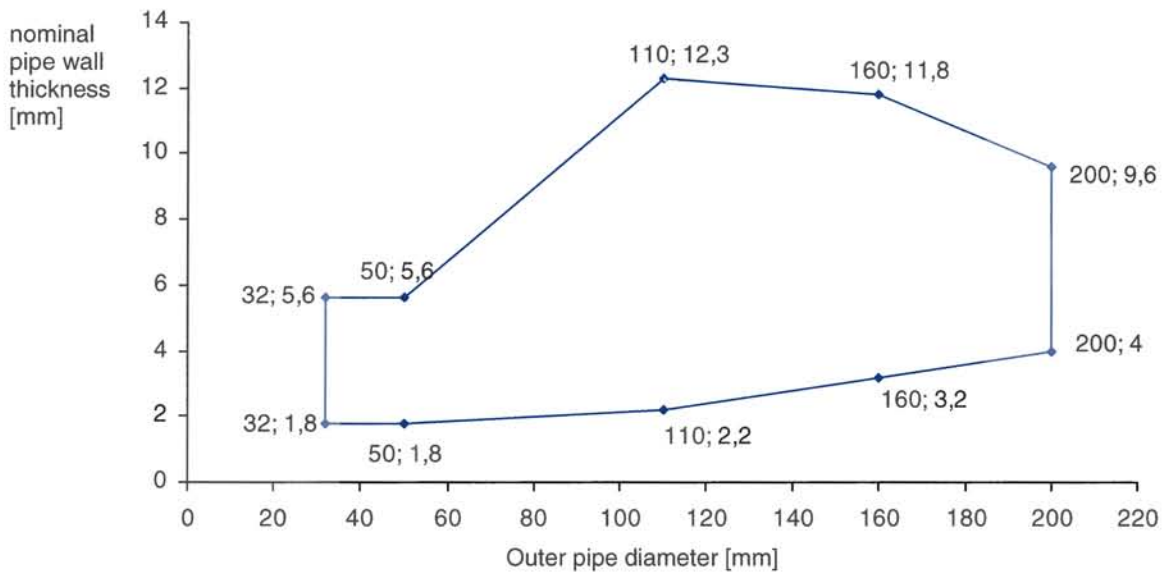

Figure 6: Pipes according to pipe group A (PVC): Installation in rigid floors; $d_D \geq 150$ mm; Fire resistance class EI 120-U/C



"ROKU System AWM II"

APPENDIX 2 – FIELD OF APPLICATION
Pipe dimensions for pipes of pipe group A ("PVC")

Annex 11

English translation prepared by DIBt

Figure 7: Pipes according to pipe group A (PVC): Installation in rigid floors; $d_D \geq 350$ mm; Fire resistance class EI 120-U/C

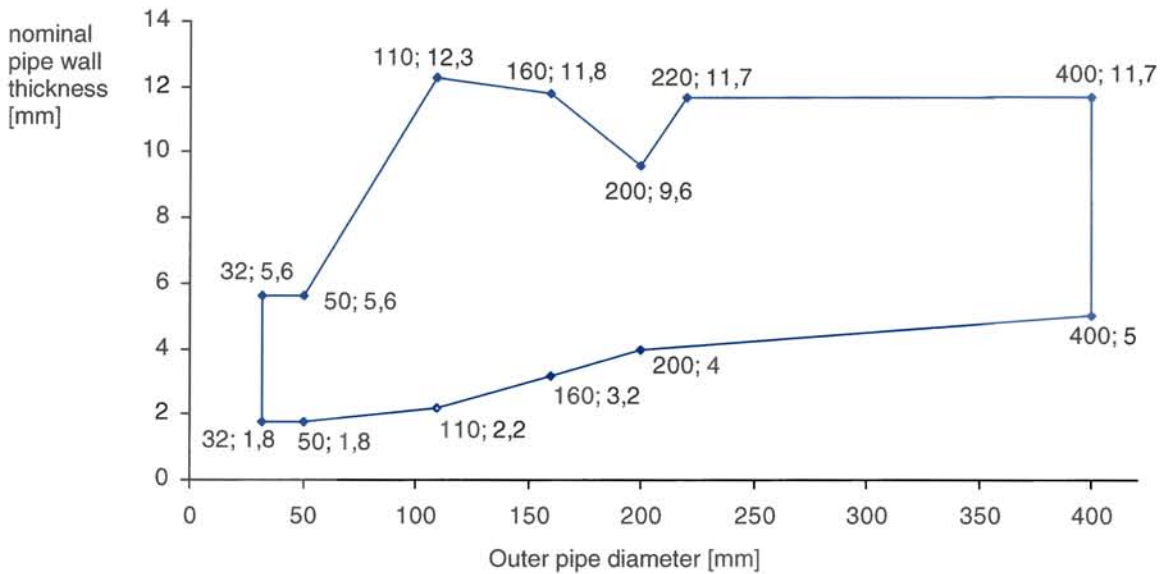
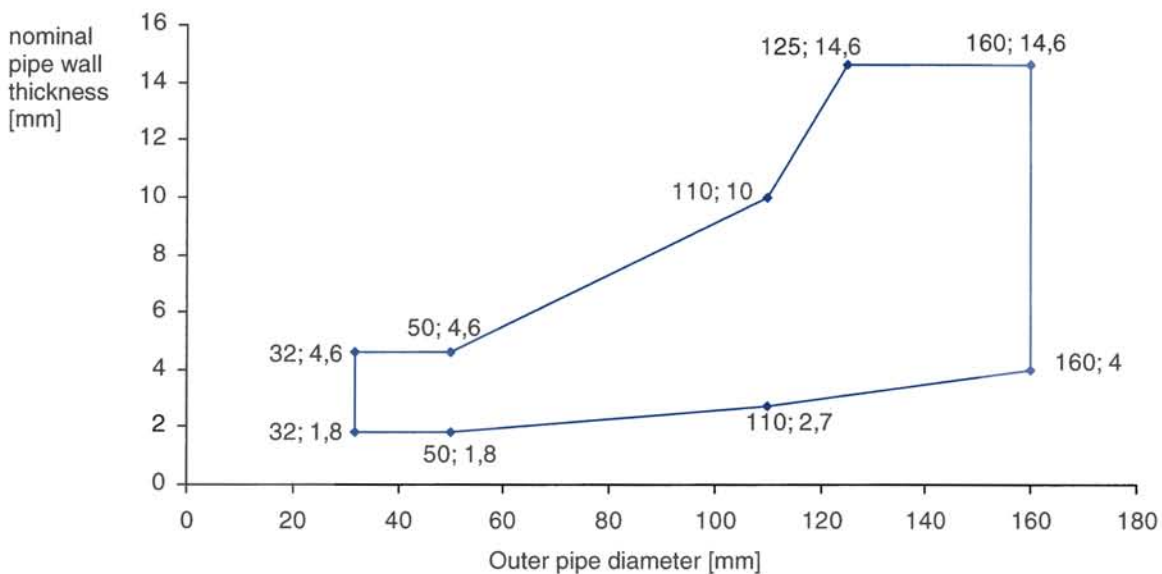

Figure 8: Pipes according to pipe group B (PE-HD): Installation in flexible walls and rigid walls; $d_W \geq 100$ mm; Fire resistance class EI 120-U/C



"ROKU System AWM II"

APPENDIX 2 – FIELD OF APPLICATION

Pipe dimensions for pipes of pipe groups A ("PVC") and B ("PE")

Annex 12

English translation prepared by DIBt

Figure 9: Pipes according to pipe group B (PE-HD): Installation in rigid walls; $d_w \geq 100$ mm; Fire resistance class EI 120-U/C

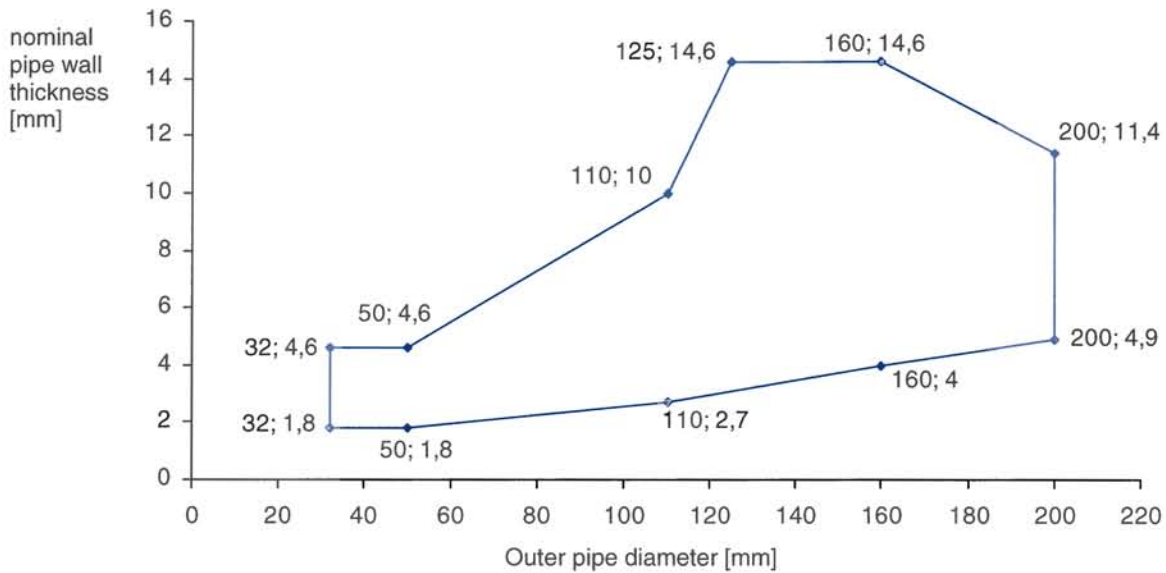
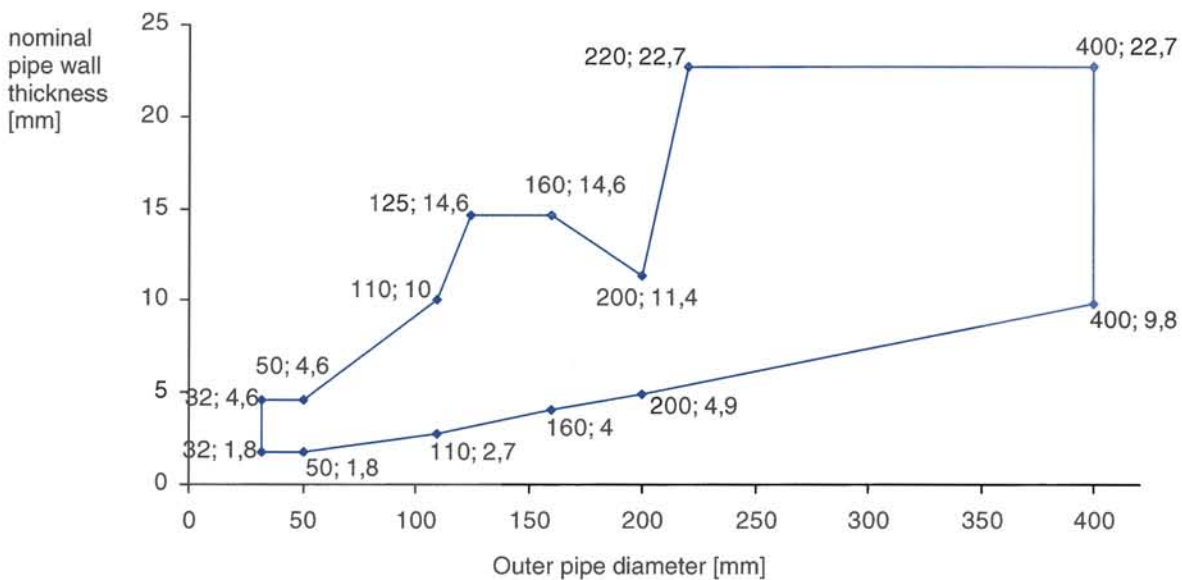

Figure 10: Pipes according to pipe group B (PE-HD): Installation in rigid walls; $d_w \geq 300$ mm; Fire resistance class EI 120-U/C



"ROKU System AWM II"

APPENDIX 2 – FIELD OF APPLICATION
Pipe dimensions for pipes of pipe group B ("PE")

Annex 13

English translation prepared by DIBt

Figure 11: Pipes according to pipe group B (PE-HD): Installation in rigid floors; $d_D \geq 150$ mm; Fire resistance class EI 120-U/C

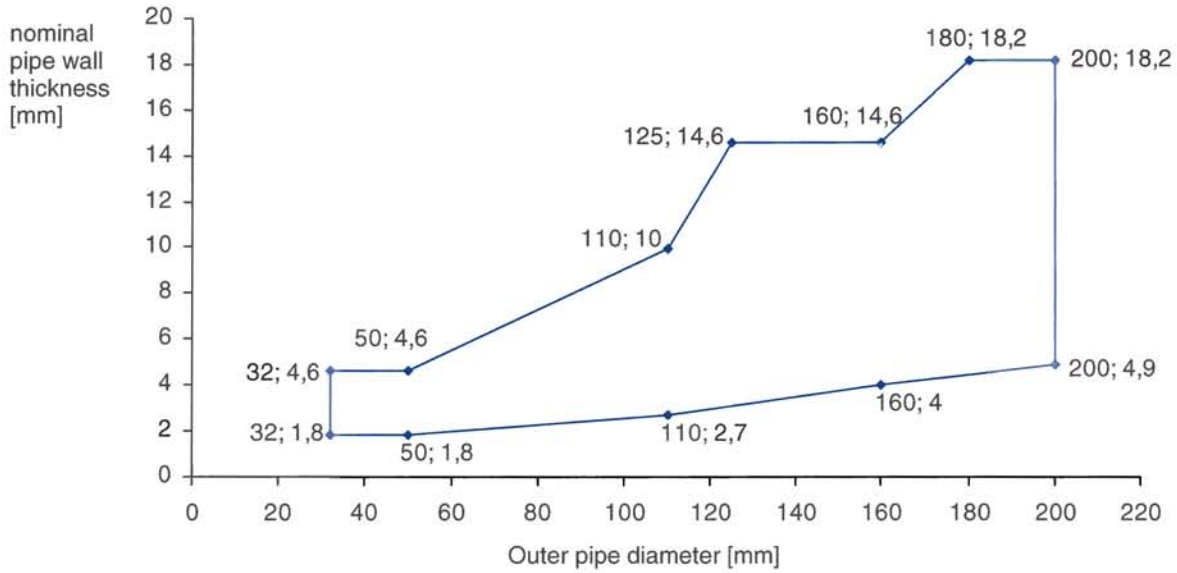
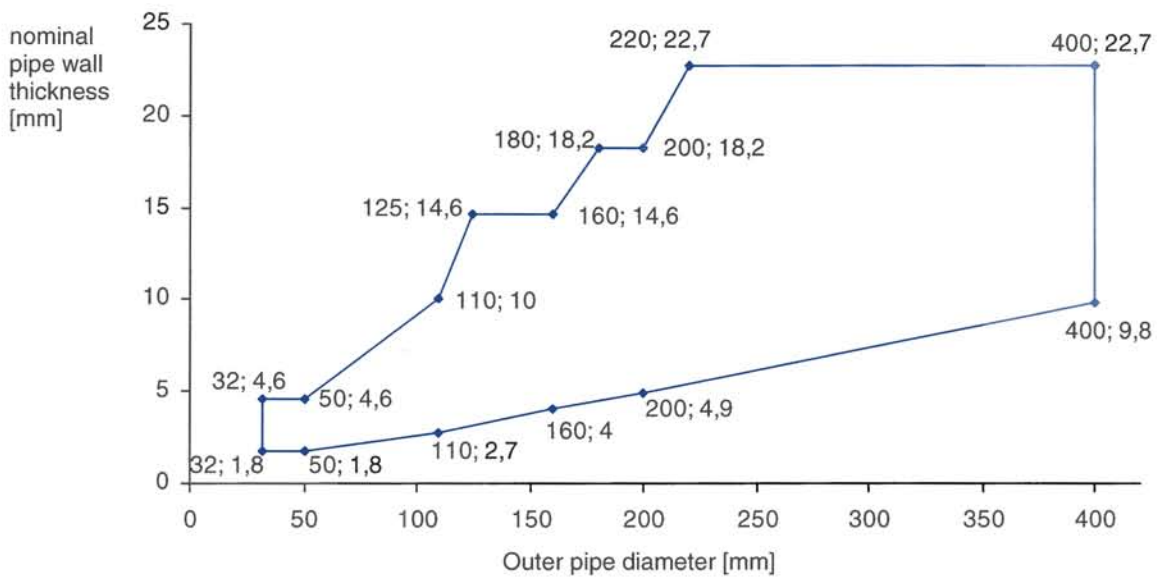

Figure 12: Pipes according to pipe group B (PE-HD): Installation in rigid floors; $d_D \geq 300$ mm; Fire resistance class EI 120-U/C



"ROKU System AWM II"

APPENDIX 2 – FIELD OF APPLICATION
Pipe dimensions for pipes of pipe group B ("PE")

Annex 14

English translation prepared by DIBt

Figure 13: Pipes according to pipe group C (PP): Installation in flexible walls and rigid walls; $d_w \geq 100$ mm; Fire resistance class EI 120-U/C

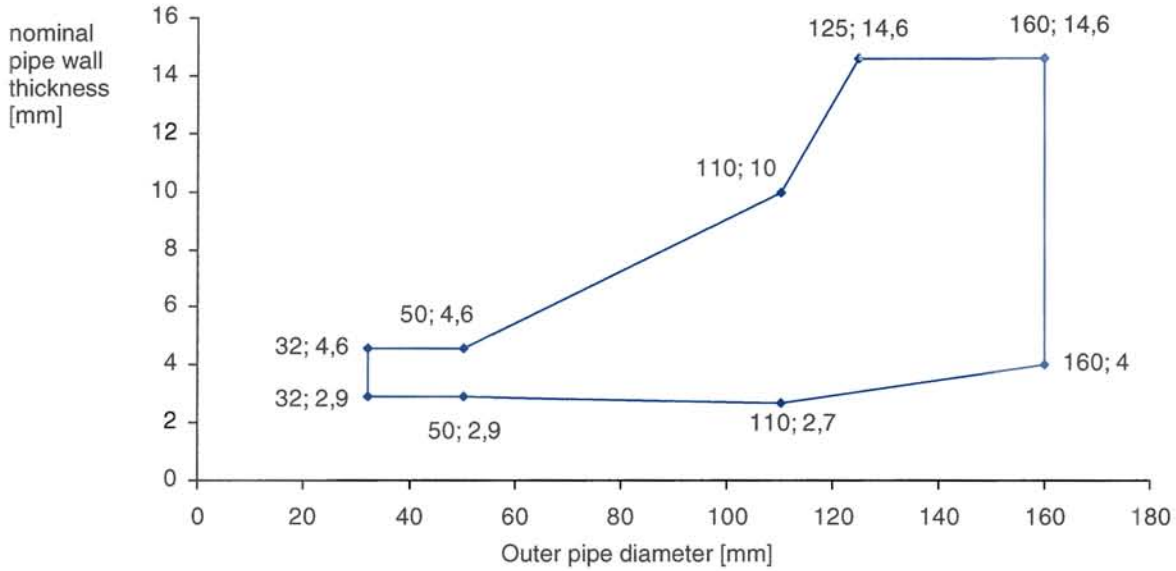
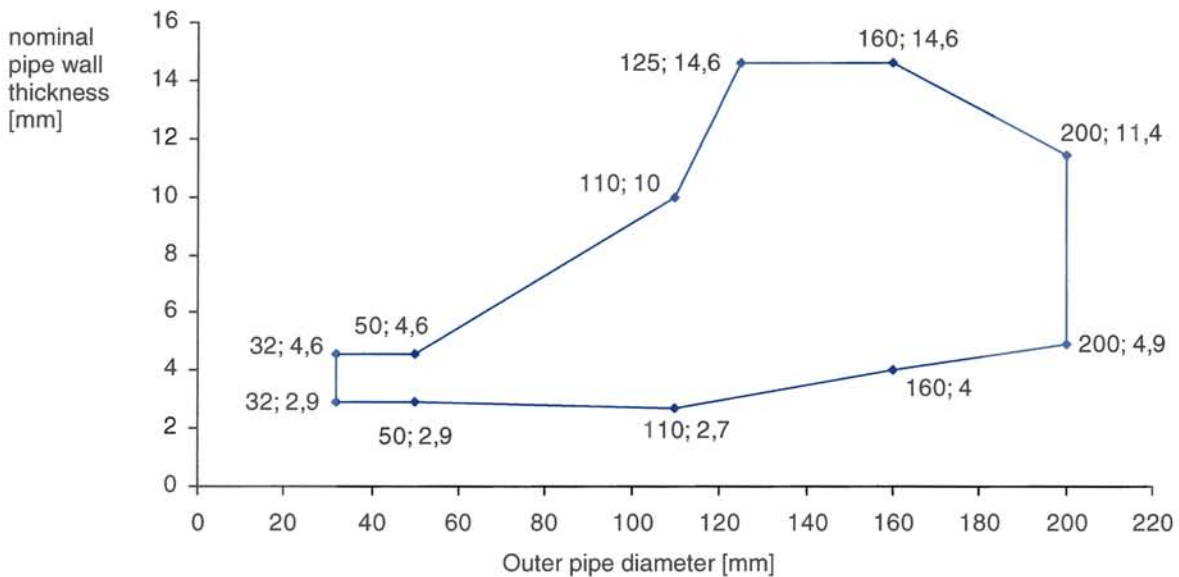

Figure 14: Pipes according to pipe group C (PP): Installation in rigid walls; $d_w \geq 100$ mm; Fire resistance class EI 120-U/C



"ROKU System AWM II"

APPENDIX 2 – FIELD OF APPLICATION
Pipe dimensions for pipes of pipe group C ("PP")

Annex 15

English translation prepared by DIBt

Figure 15: Pipes according to pipe group C (PP): Installation in rigid floors; $d_D \geq 150$ mm; Fire resistance class EI 120-U/C

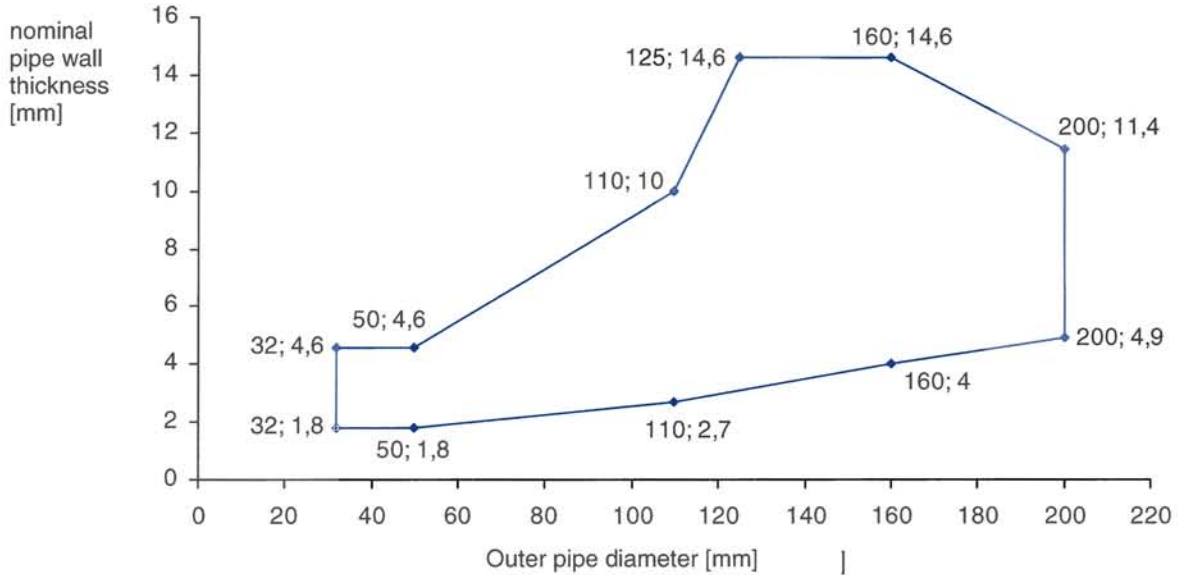
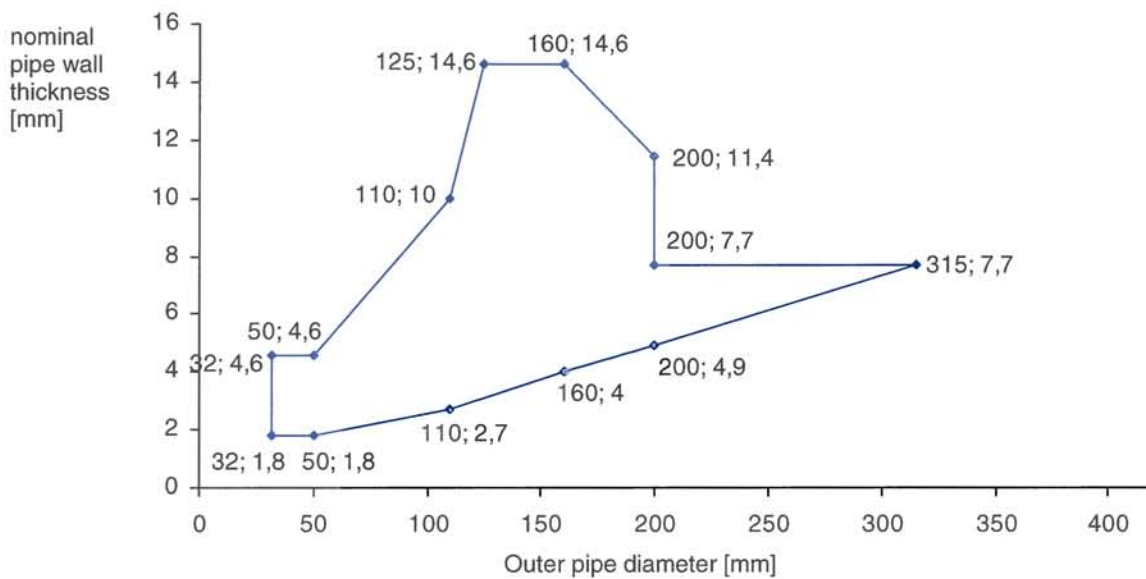

Figure 16: Pipes according to pipe group C (PP): Installation in rigid floors; $d_D \geq 300$ mm; Fire resistance class EI 120-U/C



"ROKU System AWM II"

APPENDIX 2 – FIELD OF APPLICATION
Pipe dimensions for pipes of pipe group C ("PP")

Annex 16

INSTALLATION OF THE PENETRATION SEAL

1. General

- 1.1 Before commencing installation of the penetration seal it shall be checked that all the conditions (e.g. type and thickness of the wall or floor, type and dimensions of the pipes and insulation and the ambient conditions) comply with the provisions of section 1.2 and Annexes 1 and 2.
- 1.2 It shall be ensured that the assumptions under which the fitness for use was evaluated are complied with (see Section 4.1).

2. Selection of pipe collars

- 2.1 For pipes of group A, B or C pipe collar "AWM II" or pipe collar "AWM II Light" may be used. For pipes of group D ("CoolFit") pipe collar "AWM II" shall be used.
- 2.2 The smallest pipe collar assigned to the relevant external pipe diameter according to the Annexes 1 to 3 shall be used.

3. Arrangement of pipe collars

For pipe penetrations in floors, one pipe collar according to section 2.1.1 shall be fitted at the underside of the floor. For pipe penetrations in walls one pipe collar shall be fitted on each side of the wall (see Annexes 4 and 5).

4. Fixing of pipe collars and closing of remaining gaps

- 4.1 The pipe collars shall be fixed to rigid walls or floors via their fixing lugs with adequate steel screws and - if appropriate – with adequate anchors (each with a diameter of 6 mm or 8 mm; see Annexes 4 and 5). The number of fasteners shall apply to the specifications of Appendix 1, depending on the size of the collar.

When fixing the collars with anchors the required edge distances shall be observed.

- 4.2 The pipe collars shall be fixed to flexible walls with threaded bolts (with a diameter of 6 mm or 8 mm and a length greater than the wall thickness) reaching through the wall; this type of fixing may also be used for rigid building elements (see Annex 4).
- 4.3 Prior to the installation of the pipe collars the remaining gap/joint between the wall or floor and the penetrating pipe shall be completely filled with a dimensionally stable non-combustible (class A1 or A2-s1,d0 according to EN 13501-1) material, as e.g. concrete, cementitious or gypsum mortar, over the entire building element's thickness (see Annexes 4 and 5).

"ROKU System AWM II"

APPENDIX 3 – INSTALLATION OF THE PENETRATION SEAL

Annex 17

English translation prepared by DIBt

 XXXX
Rolf Kuhn GmbH Jägersgrund 10 57339 Erndtebrück DEUTSCHLAND/GERMANY 11 XXXX-CPD-XXXX
ETA-11/0208 ETAG 026 – Teil 2/Part 2 Rohrabschottung/ Pipe Penetration Seal "ROKU® System AWM II" Rohrmanschette/ Pipe collar "AWM II" Nutzungskategorie/ Use category X

"CE"-Zeichen / "CE" marking

Identifizierungsnummer der notifizierten Stelle (für Konformitätsbescheinigungssystem 1)/ Identification number of notified certification body

Name und Anschrift des Herstellers oder seines autorisierten Vertreters (verantwortliche juristische Person)/ Name and address of the producer (legal entity responsible for the manufacturer)

Die letzten beiden Ziffern des Jahres, in dem die CE-Kennzeichnung angebracht wurde/ Two last digits of year of affixing CE marking

Nummer des EG-Konformitätszertifikats (für Konformitätsbescheinigungssystem 1)/ Number of EC certificate of conformity

Nummer der ETA / ETA number

Nummer der Leitlinie / ETAG number

Produktbezeichnung (Handelsname) / Designation of the product (trade name)

Produktbezeichnung der Komponente (Handelsname) / Designation of the component (trade name)

Nutzungskategorie/ Use category

Für weitere relevante Produktmerkmale (z.B. Feuerwiderstandsklasse, Abgabe gefährlicher Stoffe) s. ETA-11/0208/ See ETA-11/0208 for other relevant characteristics (i.e. fire resistance class, dangerous substances)

"ROKU System AWM II"

APPENDIX 4 – EXAMPLE FOR CE MARKING AND ADDITIONAL INFORMATION

Annex 18

English translation prepared by DIBt

Abbreviations

- FWKL:** maximum fire resistance class; If installed in building elements of the same type, thickness, density and with the same structure, but with a lower fire resistance class, the fire resistance class of the pipe penetration seal is reduced to the fire resistance class of the building element.
- LTW:** flexible wall according to annex 6
- MW:** rigid wall according to annex 6
- D:** rigid floor according to annex 6
- d_w:** thickness of the wall
- d_D:** thickness of the floor
- d_A:** outer pipe diameter (nominal diameter according to the standards)
- s:** pipe wall thickness (nominal value according to the standards)

Standards

- EN 13501-2:2010-02** Fire classification of construction products and building elements – Part 2: Classification using test data from resistance to fire tests, excluding ventilation services
- EN 13501-1:2007** Fire classification of construction products and building elements – Part 1: Classification using test data from reaction to fire tests
- prEN 1366-3: 07/2007** Document from CEN TC 127 for formal vote (document N 185); title see EN 1366-3: 2009-07
- EN 1366-3: 2009-07** Fire resistance tests for service installations – Part 3: Penetration seals

Other documents

- ETAG 026-2** Guideline for European Technical Approval of Fire Stopping and Fire Sealing Products, Part 2, Penetration Seals (edition January 2008)
- EOTA TR 024** Characterisation, Aspects of Durability and Factory Production Control for Reactive Materials, Components and Products (edition November 2006)

"ROKU System AWM II"	Annex 19
APPENDIX 5 – ABBREVIATIONS AND REFERENCE DOCUMENTS	