



European Technical Approval ETA-11/0209

English translation prepared by DIBt - Original version in German language

Handelsbezeichnung <i>Trade name</i>	"HENSOMASTIK Kombi-Schottsystem" "HENSOMASTIK Kombi-Schottsystem"
Zulassungsinhaber <i>Holder of approval</i>	Rudolf Hensel GmbH Lack- und Farbenfabrik Lauenburger Landstraße 11 21039 Börnsen DEUTSCHLAND
Zulassungsgegenstand und Verwendungszweck <i>Generic type and use of construction product</i>	Kombiabschottung <i>Mixed penetration seal</i>
Geltungsdauer: <i>Validity:</i>	vom <i>from</i> bis <i>to</i> 22 June 2011 22 June 2016
Herstellwerk <i>Manufacturing plant</i>	Rudolf Hensel GmbH Lack- und Farbenfabrik Lauenburger Landstraße 11 21039 Börnsen DEUTSCHLAND

Diese Zulassung umfasst
This Approval contains

24 Seiten einschließlich 15 Anlagen
24 pages including 15 annexes

I LEGAL BASES AND GENERAL CONDITIONS

- 1 This European technical approval is issued by Deutsches Institut für Bautechnik in accordance with:
 - Council Directive 89/106/EEC of 21 December 1988 on the approximation of laws, regulations and administrative provisions of Member States relating to construction products¹, modified by Council Directive 93/68/EEC² and Regulation (EC) N° 1882/2003 of the European Parliament and of the Council³;
 - Gesetz über das In-Verkehr-Bringen von und den freien Warenverkehr mit Bauprodukten zur Umsetzung der Richtlinie 89/106/EWG des Rates vom 21. Dezember 1988 zur Angleichung der Rechts- und Verwaltungsvorschriften der Mitgliedstaaten über Bauprodukte und anderer Rechtsakte der Europäischen Gemeinschaften (Bauproduktengesetz - BauPG) vom 28. April 1998⁴, as amended by law of 31 October 2006⁵;
 - Common Procedural Rules for Requesting, Preparing and the Granting of European technical approvals set out in the Annex to Commission Decision 94/23/EC⁶;
 - Guideline for European technical approval of "Fire stopping, fire sealing and fire protective products – Part 2: Penetration seals", ETAG 026-02.
- 2 Deutsches Institut für Bautechnik is authorized to check whether the provisions of this European technical approval are met. Checking may take place in the manufacturing plant. Nevertheless, the responsibility for the conformity of the products to the European technical approval and for their fitness for the intended use remains with the holder of the European technical approval.
- 3 This European technical approval is not to be transferred to manufacturers or agents of manufacturers other than those indicated on page 1, or manufacturing plants other than those indicated on page 1 of this European technical approval.
- 4 This European technical approval may be withdrawn by Deutsches Institut für Bautechnik, in particular pursuant to information by the Commission according to Article 5(1) of Council Directive 89/106/EEC.
- 5 Reproduction of this European technical approval including transmission by electronic means shall be in full. However, partial reproduction can be made with the written consent of Deutsches Institut für Bautechnik. In this case partial reproduction has to be designated as such. Texts and drawings of advertising brochures shall not contradict or misuse the European technical approval.
- 6 The European technical approval is issued by the approval body in its official language. This version corresponds fully to the version circulated within EOTA. Translations into other languages have to be designated as such.

¹ Official Journal of the European Communities L 40, 11 February 1989, p. 12
² Official Journal of the European Communities L 220, 30 August 1993, p. 1
³ Official Journal of the European Union L 284, 31 October 2003, p. 25
⁴ *Bundesgesetzblatt Teil I 1998*, p. 812
⁵ *Bundesgesetzblatt Teil I 2006*, p. 2407, 2416
⁶ Official Journal of the European Communities L 17, 20 January 1994, p. 34

II SPECIFIC CONDITIONS OF THE EUROPEAN TECHNICAL APPROVAL

1 Definition of product and intended use

1.1 Definition of the construction product

1.1.1 Description of the mixed penetration seal

The mixed penetration seal called "HENSOMASTIK Kombi-Schottsystem" mainly consists of mineral fibre boards, a coating with an ablative material and – depending on the installations passing through – of local insulations and/or pipe collars as appropriate (see Appendix 1). The mixed penetration seal shall be constructed in accordance with Appendix 3 using the components listed in Appendix 1.

1.1.2 Description of the components of the mixed penetration seal

- The mineral fibre boards, called "Hardrock II", produced by Deutsche Rockwool Mineralwoll GmbH,
 - the ablative materials, called "HENSOMASTIK 5 KS", "HENSOMASTIK 5 KS viskos" or "HENSOMASTIK 5 KS SP", produced by Rudolf Hensel GmbH,
 - the pipe shells for the local insulation, called "Rockwool 800 Rohrschale", produced by Deutsche Rockwool Mineralwoll GmbH and
 - the pipe collars, called "AWM II Light", produced by Rolf Kuhn GmbH
- shall comply with the specifications given in Annex 1.

1.2 Intended use

1.2.1 General

- 1.2.1.1 The mixed penetration seal is used to seal off openings in accordance with section 1.2.3 in fire resistant walls and floors in accordance with section 1.2.2 penetrated by installations in accordance with section 1.2.4⁷ and serves to preserve the fire resistance of the wall or floor in the vicinity of the penetrations.
- 1.2.1.2 Depending on the design of the penetration seal the mixed penetration seal reaches a maximum fire resistance class of EI 60 (EI 60-U/U for plastic pipes and EI 60-U/C for metal pipes) (see also section 2.3).
- 1.2.1.3 The mixed penetration seal can be used in interiors with and without moisture loads (see section 2.5). Suitability for external use was demonstrated for the ablative components (use category X in accordance with EOTA TR 024).
- 1.2.1.4 The mixed penetration seal can also be used to seal openings which have not yet been used for installations. Modifications may be made to the installations subsequently (retrofitting or removal of installations) provided compliance with the provisions of this European technical approval is ensured.

1.2.2 Building elements

The mixed penetration seal may be used in flexible walls (thickness $d_w \geq 94$ mm), rigid walls (thickness $d_w \geq 100$ mm) and rigid floors (thickness $d_b \geq 150$ mm) in accordance with Appendix 2, which are classified in accordance with the required fire resistance duration according to EN 13501-2 (max. EI 60).

⁷ The technical provisions of the member states for the design of piping systems and the reliability of pipe penetrations are not affected by this.

1.2.3 Openings (in the building elements)

- 1.2.3.1 The dimensions of the openings to be sealed off shall not exceed 1200 mm (width) x 1200 mm (height) in walls.

In floors the width shall not exceed 600 mm. For openings with a width between 550 mm and 600 mm the length shall not exceed 1800 mm. For openings with a width < 550 mm there are no length restrictions.

- 1.2.3.2 There shall be a distance of at least 200 mm between the opening to be sealed off and other openings or components. The distance between adjacent penetration seals according to this ETA can be reduced to 10 cm if the openings to be sealed off are no larger than 200 mm x 200 mm.

1.2.4 Installations

- 1.2.4.1 The mixed penetration seal may be used on cables, cable supporting constructions (cable trays or ladders), combustible and/or non-combustible pipes in accordance with Appendix 2. The total permitted cross section of the installations (relative to the respective external dimensions; including cable supporting constructions) may not exceed 60% of the opening. The installations shall be fixed perpendicularly to the surface of the wall and penetration seal. The distances between the individual installations and between the installations and the seal edge shall comply with the specifications in Appendix 2, taking into account the type of the installation.

- 1.2.4.2 The pipe work shall only be used for non-combustible liquids and fluids, pneumatic dispatch systems or vacuum cleaning pipes.

The regulations of the member states shall be observed for more precise specifications of the pipe works (intended use of pipes) for which the penetration seal may be used (e.g. drinking water pipes, heating pipes, waste water pipes)⁸.

The suitability of the mixed penetration seal in accordance with this European technical approval on pipes was demonstrated using the U/U (plastic pipes) and U/C (metal pipes) test conditions, which means that all possible classifications (pipe end situations) are covered in accordance with EN 1366-3.

1.2.5 Working life

The provisions in this European technical approval are based on an assumed working life of 10 years for the mixed penetration seal "HENSOMASTIK Kombi-Schottsystem" provided the conditions laid down in sections 4 and 5 relating to manufacturing, installation, use and repair are met. The information provided on the working life cannot be interpreted as a guarantee given by the manufacturer, but should be regarded only as a means for choosing the right products in relation to the expected economically reasonable working life of the construction.

2 Product characteristics and methods of verification

2.1 General

- 2.1.1 The fitness of the mixed penetration seal for the intended use was evaluated in accordance with ETAG 026 Part 2: 2008-01-01.

For the evaluation of the mixed penetration seal, the product characteristics "reaction to fire", "fire resistance", "emission of dangerous substances" as well as "durability and serviceability" were taken into consideration.

- 2.1.2 The product characteristics specified in sections 2.2 to 2.5 only apply to the penetration seal and its components described in this ETA. Deutsches Institut für Bautechnik shall be immediately notified of any changes to the materials, composition, dimensions or properties of

⁸ The penetration seal may only be fitted to these pipe work types if it fulfils the classification required in the respective country. Particular attention must be paid to the ending of the classification, which reflects the pipe end situation from the fire resistance tests performed to prove serviceability (see section 2.2).

these components. Deutsches Institut für Bautechnik will then decide if a new evaluation is required.

2.2 Reaction to fire

The mineral fibre boards, the pipe shells for the local insulation, the components of the pipe collars and the ablative components comply with the fire reaction classes in accordance with EN 13501-1 specified in Annex 1.

2.3 Fire resistance

The mixed penetration seal was tested in accordance with prEN 1366-3: 07/2007. As a maximum, the penetration seal fulfils the requirements of Class EI 60 (ending for plastic pipes -U/U and for metal pipes – U/C) in accordance with EN 13501-2.

In the annexes the maximum verified fire resistance class – under the respective installation conditions – is specified. If installed in walls of the same thickness and density and with the same structure as specified there, but with a lower fire resistance class, the fire resistance class of the mixed penetration seal is reduced to the fire resistance class of the wall.

The fire resistance classes specified in the annexes with the endings –U/U (plastic pipes) or – U/C (metal pipes) cover the classes of the same fire resistance duration, but with the other possible endings in accordance with EN 13501-2.

2.4 Emission of dangerous substances

The ablative components "HENSOMASTIK 5 KS", "HENSOMASTIK 5 KS viskos", "HENSOMASTIK 5 KS SP" and the intumescent inlay of the collar "AWM II Light" do not contain substances registered as dangerous substances in the list of the European Commission.

For assessment purposes, the chemical compositions of the materials were made available to the Deutsches Institut für Bautechnik.

For the mineral fibre boards "Hardrock II" and the pipe shells "Rockwool 800" manufacturer's declarations, that these products do not contain dangerous substances specified in Directive 67/548/EEC or Regulation (EC) N° 1272/2008 or the Indicative List on Dangerous Substances were made available to the Deutsches Institut für Bautechnik.

Note: In addition to the specific clauses relating to dangerous substances contained in this European technical approval, there may be other requirements applicable to the products falling within its scope (e.g. transposed European legislation and national laws, regulations and administrative provisions). In order to meet the provisions of the Construction Products Directive, these requirements need also to be complied with, when and where they apply.

2.5 Durability and serviceability

The ablative materials "HENSOMASTIK 5 KS", "HENSOMASTIK 5 KS viskos" or "HENSOMASTIK 5 KS SP" fulfil the requirements of use category X in accordance with EOTA TR 024. That means that the materials can be exposed to the conditions in interiors with and without moisture loads and external weathering, without expecting significant changes in fire protection characteristics.

3 Evaluation and attestation of conformity and CE marking

3.1 System of attestation of conformity for the pipe collar

According to Decision 1999/454/EG, amended by Decision 2001/596/EC of the European Commission⁹, system 1 of the attestation of conformity applies.

⁹ Official Journal of the European Communities 178/52, 14 July 1999

This system of attestation of conformity is defined as follows:

System 1: Certification of the conformity of the product by an approved certification body on the basis of:

- (a) Tasks of the manufacturer:
 - (1) factory production control;
 - (2) further testing of samples taken at the factory by the manufacturer in accordance with a prescribed test plan;
- (b) Tasks of the approved body:
 - (3) initial type-testing of the product;
 - (4) initial inspection of the factory and of factory production control;
 - (5) continuous surveillance, assessment and approval of factory production control.

Note: Approved bodies are also referred to as "notified bodies".

3.2 Responsibilities

3.2.1 Tasks of the manufacturer

3.2.1.1 Factory production control

The manufacturer shall exercise permanent internal control of production. All the elements, requirements and provisions adopted by the manufacturer shall be documented in a systematic manner in the form of written policies and procedures, including records of results performed. The factory production control shall ensure that the product is in conformity with this European technical approval.

The manufacturer may only use the initial/raw/constituent materials stated in the technical documentation of this European technical approval.

The factory production control shall be in accordance with the Control plan dated 24.06.2011 relating to the European technical approval ETA-11/0209 granted on 22.06.2011, which is part of the technical documentation of this European technical approval. The control plan is laid down in the context of the factory production control system operated by the manufacturer and deposited with Deutsches Institut für Bautechnik.¹⁰

The results of factory production control shall be recorded and evaluated in accordance with the provisions of the control plan.

3.2.1.2 Other tasks of the manufacturer

The manufacturer shall provide a technical datasheet and an installation guide containing at least the following information:

Technical data sheet:

1. Field of application:

- Building elements into which the penetration seal may be installed, type and properties of the building elements, such as minimum thickness, density and – in the case of lightweight constructions – the construction requirements.
- Installations that may pass through the penetration seal, type and properties of the installations (including insulation if relevant), such as materials, diameter, thickness; necessary/permitted supports/fastenings; distances.
- Dimensions, minimum thicknesses etc. of the penetration seal
- Climatic conditions covered by the ETA: Internal use with and without moisture loads

¹⁰

The control plan is a confidential part of the European technical approval and only handed over to the approved body involved in the procedure of attestation of conformity. See section 3.2.2.

2. Construction of the penetration seal including the necessary components and additional products with clear indications whether they are generic or specific.

Installation instruction:

- Installation method (e.g. preparation of the supporting structure before installation of the penetration seal)
- The sequence of working steps to be followed
- Procedure in case of retrofitting

The manufacturer shall, on the basis of a contract, involve a body which is approved for the tasks referred to in section 3.1 for products in accordance with ETAG 026-2, in order to undertake the actions laid down in section 3.2.2. For this purpose, the control plan referred to in sections 3.2.1.1 and 3.2.2 shall be handed over by the manufacturer to the approved body involved.

The manufacturer shall make a declaration of conformity, stating that the construction product is in conformity with the provisions of the European technical approval ETA-11/0209 issued on 22.06.2011.

3.2.2 Tasks for the approved body

The approved body shall perform the following tasks in accordance with the provisions laid down in the control plan:

- Initial type-testing of the product
- Initial inspection of factory and factory production control
- Continuous surveillance, assessment and approval of factory production control

The approved body shall record the essential points of their actions referred to above and state the results obtained and conclusions made in a written report.

The approved certification body involved by the manufacturer shall issue an EC certificate of conformity of the product stating the conformity with the provisions of this European technical approval.

In cases where the provisions of the European technical approval and its control plan are no longer fulfilled, the certification body shall withdraw the certificate of conformity and inform Deutsches Institut für Bautechnik without delay.

3.3 CE marking

The CE marking shall be affixed on the packagings/cartridges of the ablative components and the accompanying commercial documents. The letters "CE" shall be followed by the identification number of the approved certification body and be accompanied by the following additional information:

- the name and address of the manufacturer (legal entity responsible for the manufacture),
- the last two digits of the year in which the CE marking was affixed,
- the number of the EC certificate of conformity for the product,
- the number of the European technical approval,
- the number of the guideline for European technical approval,
- the use category,
- the designation of the product (trade name),
- declaration of any dangerous substances or "no dangerous substances",
- "see ETA-11/0209 for other relevant characteristics".

For an example of the CE marking see Appendix 4.

4 Assumptions under which the fitness of the product for the intended use was favourably assessed

4.1 General

4.1.1 It is assumed that

- the penetration seal complies with the specifications in this ETA and the installation was carried out in accordance with this ETA and also in accordance with the technical data sheet and the installation instructions by the manufacturer,
- damages to the penetration seal are repaired accordingly,
- the seal is installed only in the building elements specified in this ETA,
- only installations in accordance with the specifications in this ETA pass through the openings (Parts or service support constructions other than those in accordance with section 1.2 shall not pass through the penetration seal.),
- the installation of the penetration seal does not affect the stability of the adjacent building elements – even in the case of fire,
- the lintel or floor above the penetration seal is designed structurally and in terms of fire protection such that no additional mechanical load (other than its own weight) is imposed on the seal,
- pneumatic dispatch systems, compressed air systems, etc. are switched off by additional means in case of fire (for sealing off plastic pipes),
- the installations are fixed to the adjacent building elements (not to the seal) in accordance with the relevant regulations in such a manner that, in case of fire, no additional mechanical load is imposed on the seal and
- the support of the installations is maintained for the classification period required.

4.1.2 This European technical approval does not address any risks associated with the emission of dangerous liquids or gases caused by failure of the pipe(s) in case of fire nor does it prove the prevention of the transmission of fire through heat transfer via the medium in the pipes.

4.1.3 This European technical approval does not prove the prevention of destruction of adjacent building elements with fire separating function or of the pipes themselves due to distortion forces caused by extreme temperatures. These risks shall be accounted for by taking appropriate measures when designing or installing the pipe work.

The mounting or hanging of the pipes or the layout of the pipe work shall be implemented in such a way that the pipes and the fire resistant building elements shall remain functional within a period of time which corresponds to the fire resistance period required.

4.1.4 The risk of downward spread of fire caused by burning material which drips through a pipe to floors below, is not considered in this ETA (see EN 1366-3: 2009-07, section 1).

4.1.5 The durability assessment does not take account of the possible effect on the penetration seal of substances permeating through the pipe walls.

4.1.6 It is assumed that to avoid injuries provisions are taken to prevent persons to step or fall onto the penetration seal (e.g. covering with a wire mesh).

4.2 Production

The European technical approval was issued for the product on the basis of agreed data/information, deposited with Deutsches Institut für Bautechnik, which identifies the product that has been assessed and judged. Changes to the product or production process, which could result in this deposited data/information being incorrect, shall be reported to Deutsches Institut für Bautechnik before the changes are introduced. Deutsches Institut für Bautechnik will decide whether or not such changes affect the approval and consequently the validity of the CE marking on the basis of the approval, and if so whether further assessment or alterations to the approval shall be necessary.

4.3 Installation

The product characteristics specified in this European technical approval only apply if the penetration seal is installed in accordance with the specifications in Appendix 3 and also with the technical data sheet and the manufacturer's installation instructions.

5 Indications to the manufacturer

5.1 Packaging, transport and storage

5.1.1 The manufacturer's specifications for packaging, transport and storage shall be observed.

5.1.2 The packaging of the ablative components shall contain the following information:

- Trade name or trademark or other symbol identifying the product
- The date of manufacture (day, month, year or coded information)

5.1.3 The ablative components shall be packaged for delivery in compliance with the usual delivery conditions and providing sufficient protection against the effects of normal handling.

5.2 Use, maintenance, repair

5.2.1 In general, no maintenance work is necessary. Repair can be implemented by installing pieces of mineral fibre boards and ablative materials and/or restoring damaged measures (i.e. local insulation or coating) on the installations in accordance with Appendix 3.

5.2.2 If individual installations are removed or added, the mineral fibre board plane shall be sealed again in accordance with Appendix 3 and measures in accordance with Appendix 3 shall be taken for the added installations.

Prof. Gunter Hoppe
Head of Department

beglaubigt:
Meske-Dallal

English translation prepared by DIBt

Name/manufacturer	Description
"Hardrock II" Deutsche Rockwool Mineralwoll GmbH, 45966 Gladbeck, Germany	Mineral fibre board in accordance EN 13162 Thickness ≥ 60 mm Nominal gross density ≥ 150 kg/m ³ Reaction to fire class according to EN 13501-1: Class A1
"HENSOMASTIK 5 KS" Rudolf Hensel GmbH, 21039 Börnsen, Germany	Ablative material , filled in cartridges or buckets Reaction to fire class according to EN 13501-1: Class E Density (condition on delivery): 1350 kg/m ³ \pm 70 kg/m ³ Content of non-volatile components*: 70% - 80% Mass loss through heating*: 44% - 54% LOI*: 45% \pm 3% Flexibility*: No cracks at ≥ 8 mm mandrel diameter (sample thickness approx. 2.4 mm)
"HENSOMASTIK 5 KS viskos"	Ablative material , filled in cartridges or buckets Reaction to fire class according to EN 13501-1: Class E Density (condition on delivery): 1,340 kg/m ³ \pm 70 kg/m ³ Content of non-volatile components*: 65.5% - 75.5% Mass loss through heating*: 48% - 58% LOI*: 43% \pm 3% Flexibility*: No cracks at ≥ 6 mm mandrel diameter (sample thickness approx. 2.6 mm)
"HENSOMASTIK 5 KS SP"	Ablative material , filled in cartridges Reaction to fire class according to EN 13501-1: Class E Density (condition on delivery): 1,350 kg/m ³ \pm 70 kg/m ³ Content of non-volatile components*: 66% - 70% Mass loss through heating*: 27% - 37% LOI*: 40% \pm 3% Flexibility*: No cracks at ≥ 10 mm mandrel diameter (sample thickness approx. 1.5 mm)
"Rockwool 800 Rohrschale" (Z-23.14-1114) Deutsche Rockwool Mineralwoll GmbH, 45966 Gladbeck Germany	Pipe shell made of concentrically wound rock wool with aluminium mesh reinforced film laminate in accordance with EN 14303 Nominal gross density ≥ 90 kg/m ³ Reaction to fire class according to EN 13501-1: Class A2 L-s1d0 Length (on both sides of the mineral fibre board plane): ≥ 1000 mm (see Annexes 4 and 7) Thickness (depending on the pipe material and pipe dimensions): See Annex 11
"AWM II Light" Rolf Kuhn GmbH, Germany	Pipe collar with a sheet steel housing and an inlay made of an intumescent material in accordance with ETA-11/0208 Reaction to fire class according to EN 13501-1 (for the components): at least Class E
*tested according to ETAG 026-2 (see also TR 024)	
"HENSOMASTIK Kombi-Schottsystem"	Annex 1
APPENDIX 1 – DESCRIPTION OF THE PRODUCT Description of the components of the product	

English translation prepared by DIBt

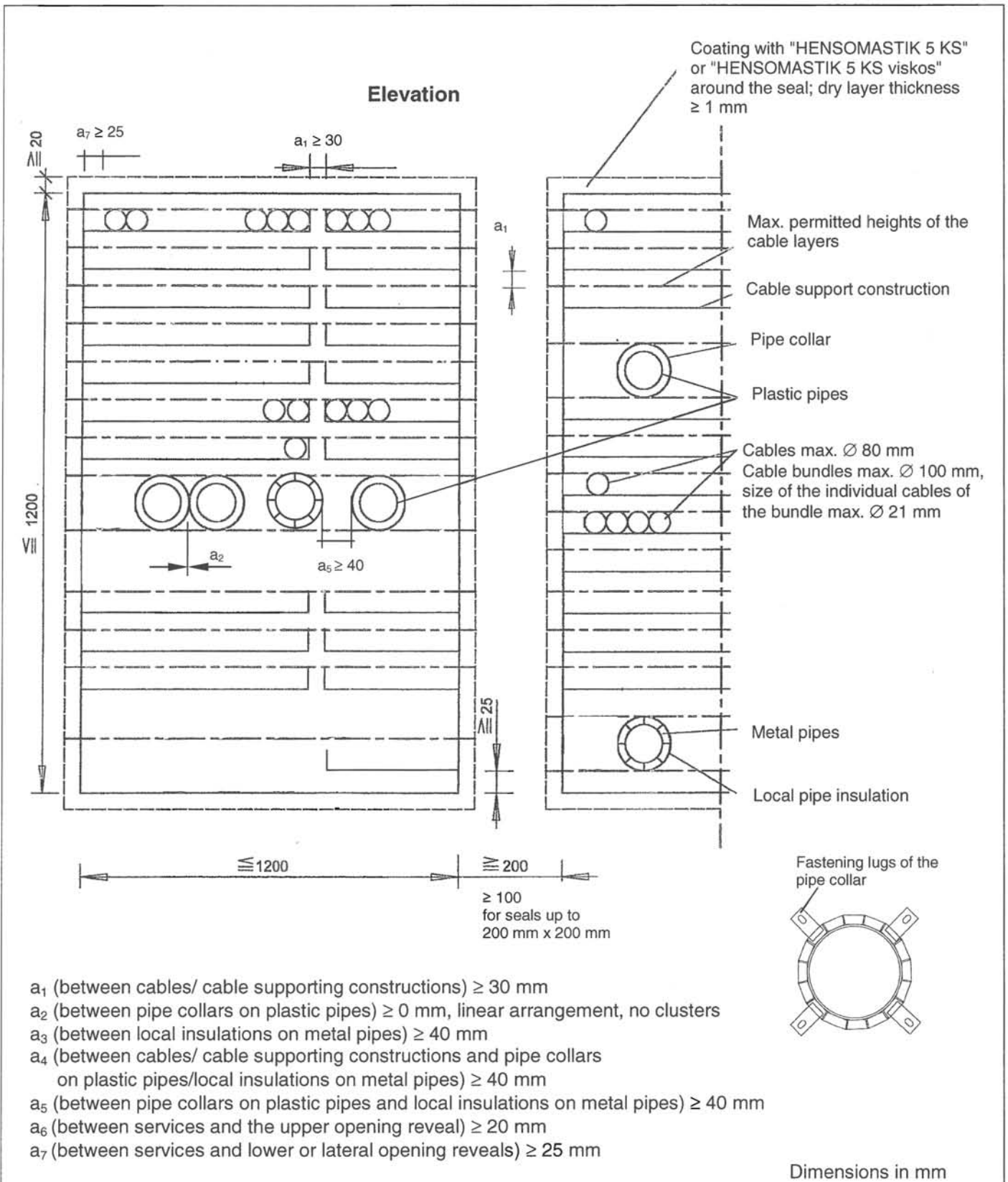

- a_1 (between cables/ cable supporting constructions) ≥ 30 mm
- a_2 (between pipe collars on plastic pipes) ≥ 0 mm, linear arrangement, no clusters
- a_3 (between local insulations on metal pipes) ≥ 40 mm
- a_4 (between cables/ cable supporting constructions and pipe collars on plastic pipes/local insulations on metal pipes) ≥ 40 mm
- a_5 (between pipe collars on plastic pipes and local insulations on metal pipes) ≥ 40 mm
- a_6 (between services and the upper opening reveal) ≥ 20 mm
- a_7 (between services and lower or lateral opening reveals) ≥ 25 mm

"HENSOMASTIK Kombi-Schottsystem"

APPENDIX 1 – DESCRIPTION OF THE PRODUCT

Design of the mixed penetration seal for wall installation; Elevation; Distances

Annex 2

English translation prepared by DIBt

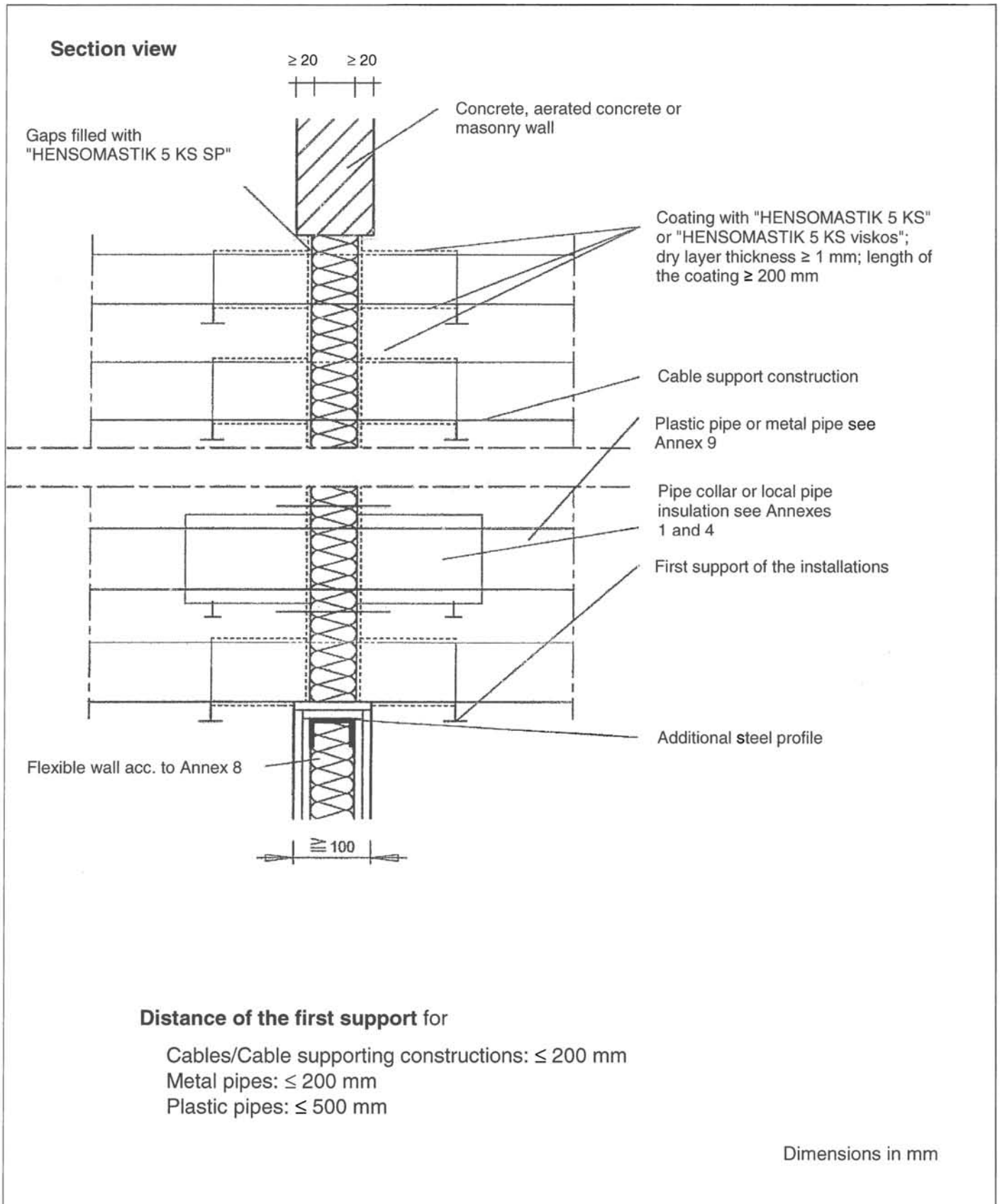

"HENSOMASTIK Kombi-Schottsystem"

APPENDIX 1 – DESCRIPTION OF THE PRODUCT

Design of the mixed penetration seal for wall installation; Section view

Annex 3

English translation prepared by DIBt

Measures on plastic pipes (pipe groups A and B)

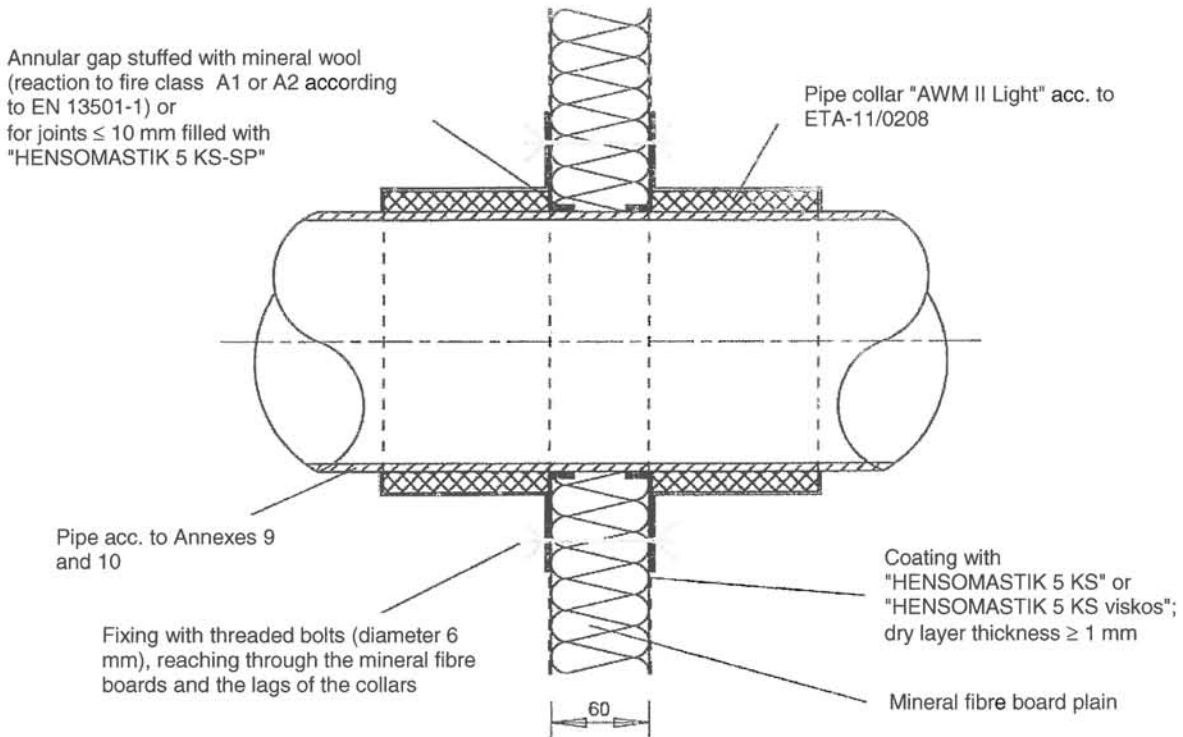

Measures on metal pipes

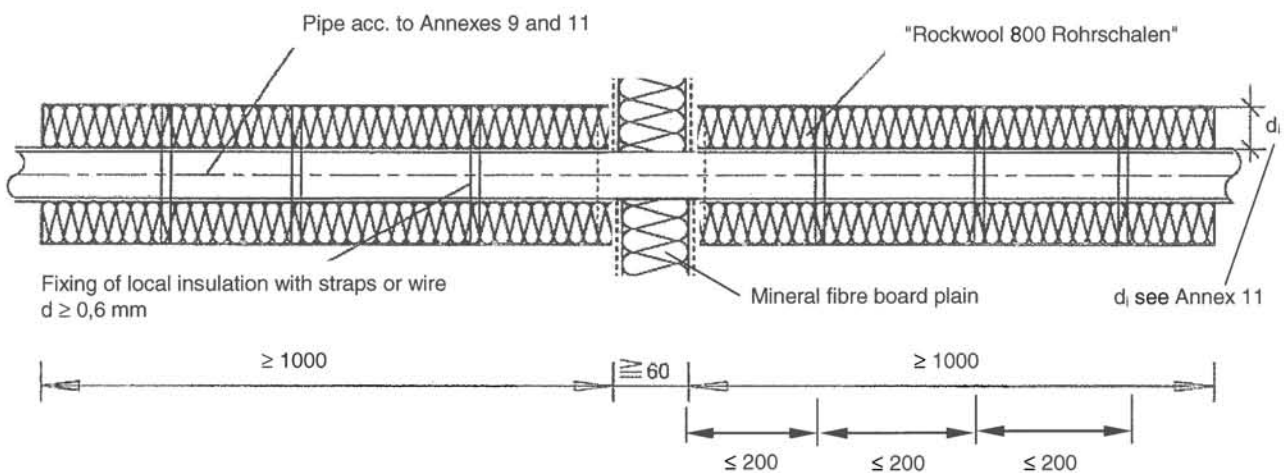

Dimensions in mm

"HENSOMASTIK Kombi-Schottsystem"

APPENDIX 1 – DESCRIPTION OF THE PRODUCT

Design of the mixed penetration seal in walls; Details for measures on pipes

Annex 4

English translation prepared by DIBt

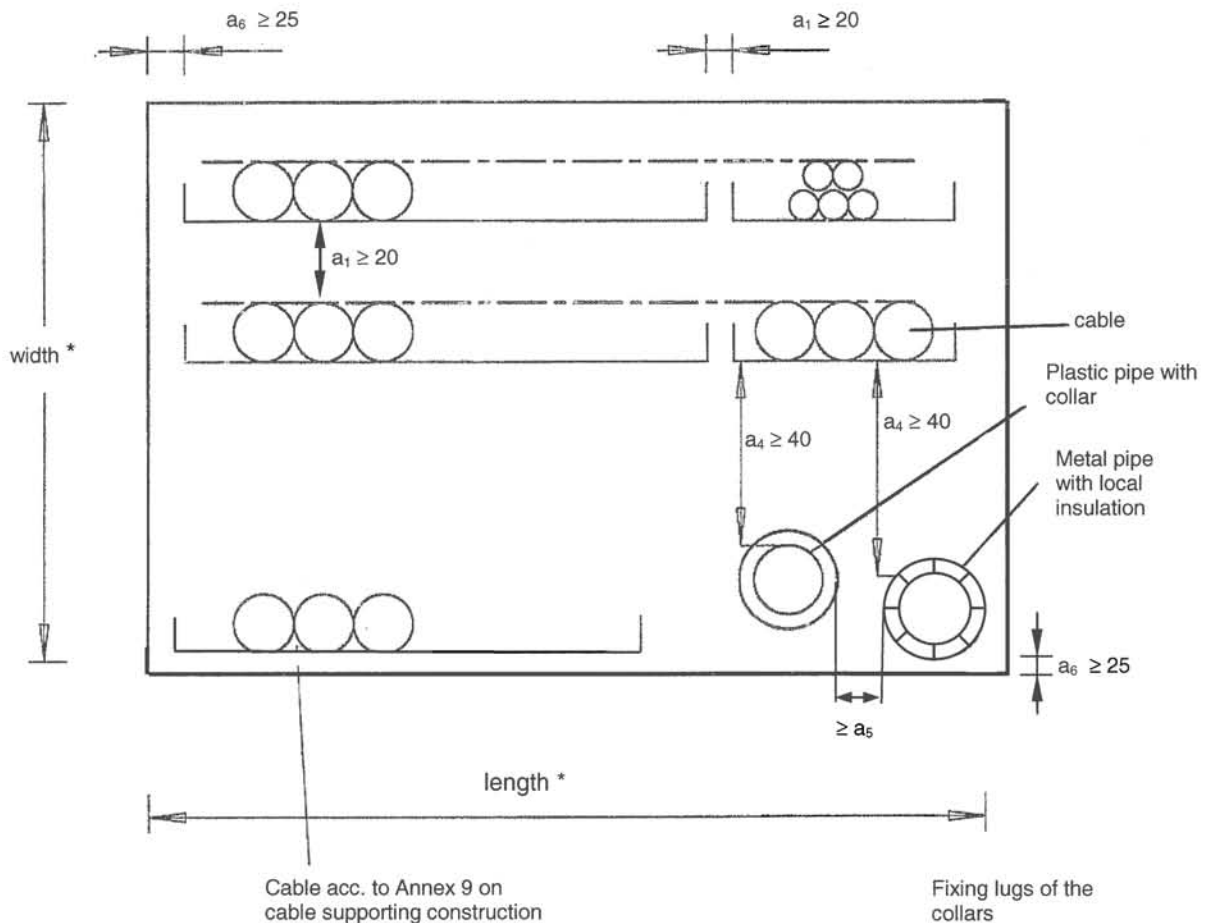

*

width	length
550-600 mm	≤ 1800 mm
< 550 mm	not restricted

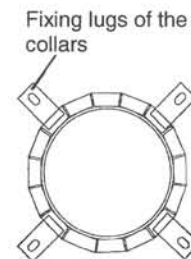

Distances a_i :

a_1 (between cables/ cable supporting constructions) ≥ 20 mm

a_2 (between pipe collars on plastic pipes) ≥ 0 mm, linear arrangement, no clusters

a_3 (between local insulations on metal pipes) ≥ 40 mm

a_4 (between cables/ cable supporting constructions and pipe collars on plastic pipes/local insulations on metal pipes) ≥ 40 mm

a_5 (between pipe collars on plastic pipes and local insulations on metal pipes) ≥ 40 mm

a_6 (between services and opening reveals) ≥ 25 mm

Dimensions in mm

"HENSOMASTIK Kombi-Schottsystem"

APPENDIX 1 – DESCRIPTION OF THE PRODUCT

Design of the mixed penetration seal for floor installation; Elevation; Distances

Annex 5

English translation prepared by DIBt

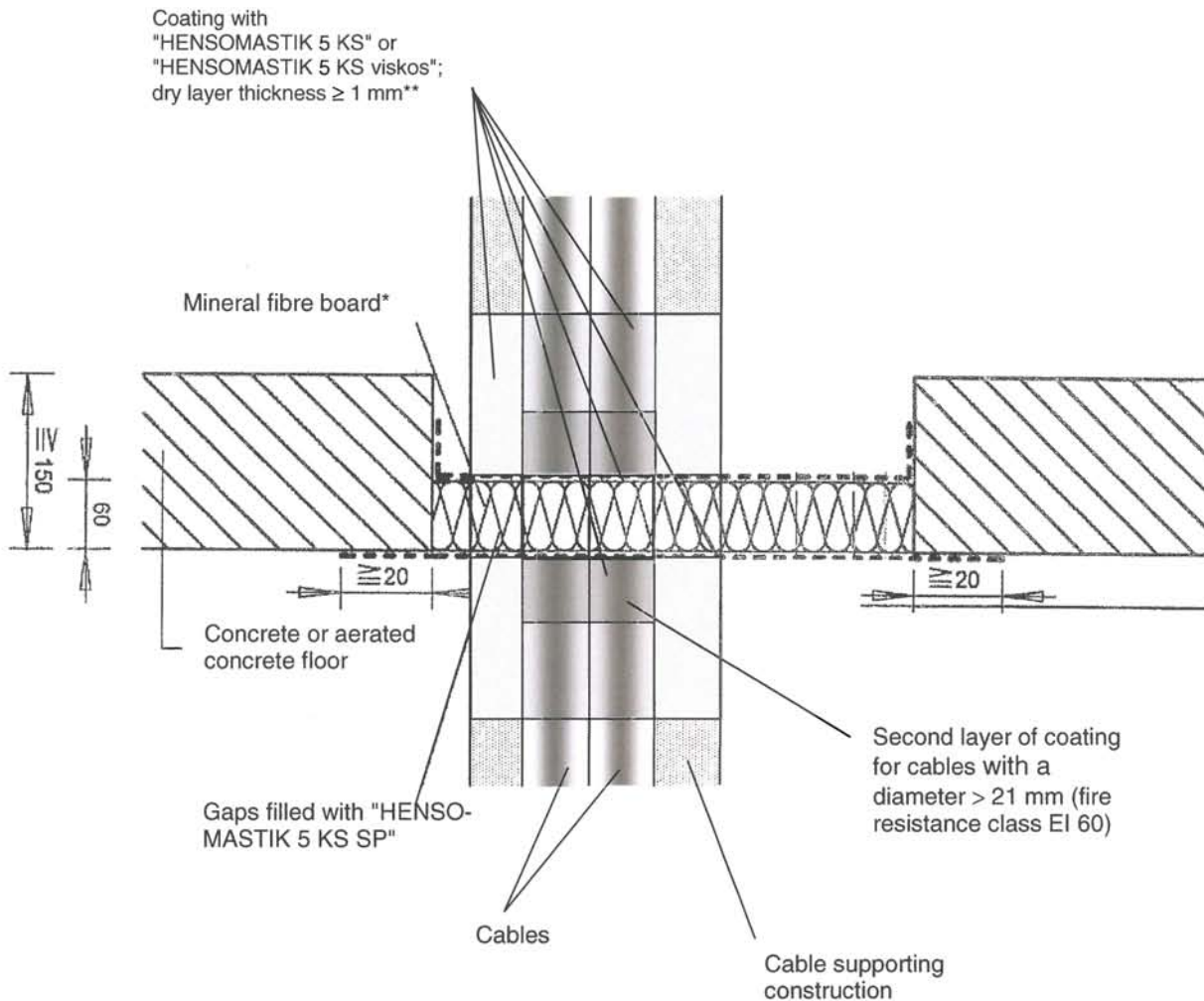

* Mineral fibre board plain either flush with the top or bottom of the floor or an installation position between the two

** Length of the coating in accordance with the following table:

Fire resistance class	Cable diameter	Coating length
EI 60	≤ 21 mm	100 mm
EI 60	> 21 mm	150 mm***
EI 30	≤ 80 mm	100 mm

***For fire resistance class EI 60: Fit cables with a diameter > 21 mm on both sides at a length of at least 30 mm with a second 1 mm thick layer of the coating

Dimensions in mm

"HENSOMASTIK Kombi-Schottsystem"

APPENDIX 1 – DESCRIPTION OF THE PRODUCT
Design of the mixed penetration seal for floor installation; Section view

Annex 6

English translation prepared by DIBt

Measures on plastic pipes (pipe groups A and B)

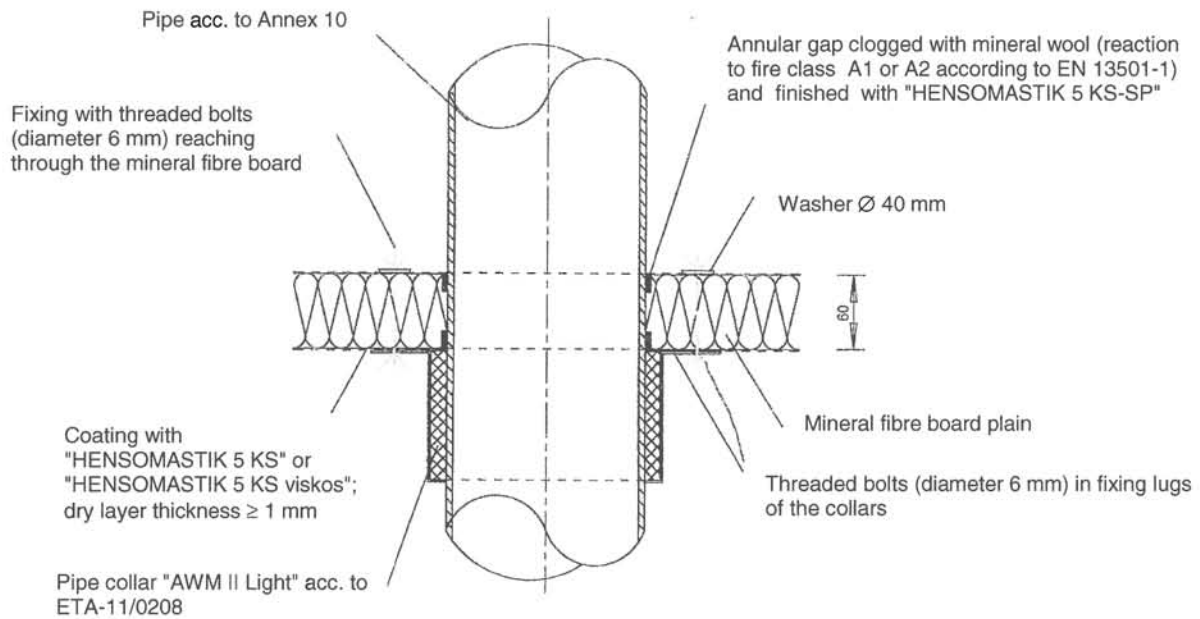

Measures on metal pipes

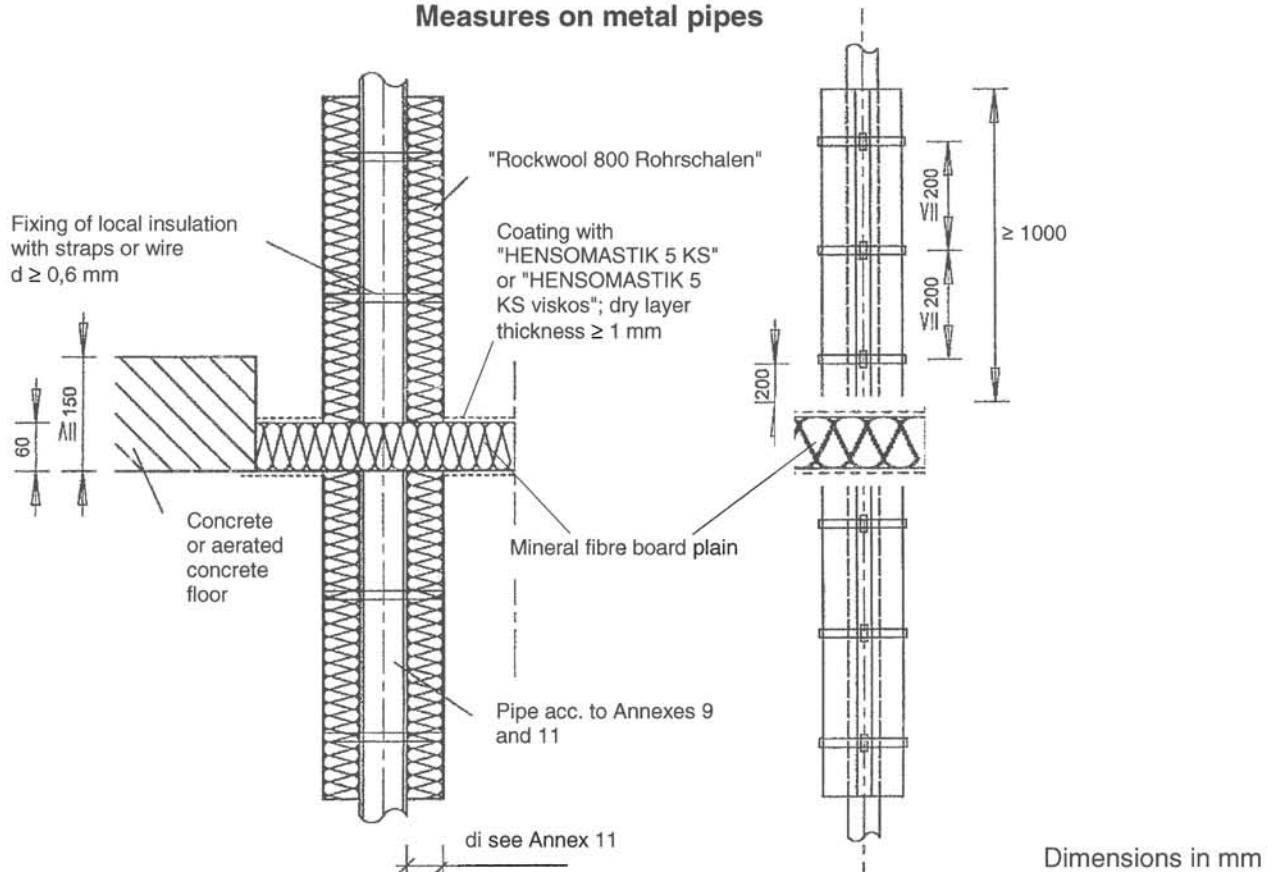

"HENSOMASTIK Kombi-Schottsystem"

APPENDIX 1 – DESCRIPTION OF THE PRODUCT

Design of the mixed penetration seal in floors; Details for measures on pipes

Annex 7

English translation prepared by DIBt

The mixed penetration seal may be used in

Rigid walls

- of masonry, concrete, reinforced concrete or aerated concrete
- density $\geq 630 \text{ kg/m}^3$
- thickness $\geq 100 \text{ mm}$
- The walls shall be classified according to EN 13501-2 (maximum EI 60) corresponding to the required fire resistance period.

Flexible walls

- flexible walls with a steel stud substructure and a lining on both sides made from min. 2 layers of 12,5 mm thick cementitious or gypsum based slabs with a fire reaction class A1 or A2 according to EN 13501-1

The framework shall be supplemented with additional transoms and mullions so that they form the reveal of the wall opening for the planned mixed penetration seal. The wall lining shall be attached to these steel profiles appropriately. The opening reveal shall be cladded as described below.

- flexible walls with a wood stud substructure and a lining on both sides made from min. 2 layers of 12,5 mm thick cementitious or gypsum based slabs with a fire reaction class A1 or A2 according to EN 13501-1

The distance between the wood substructure and the seal shall be $\geq 100 \text{ mm}$ and the cavity between the linings of the wall, the wood substructure and the seal shall be tightly clogged with mineral wool of fire reaction class A1 or A2 according to EN 13501-1 in a depth of minimum 100 mm. The opening reveal shall be cladded as described below.

- thickness $\geq 94 \text{ mm}$
- The walls shall be classified according to EN 13501-2 (maximum EI 60) corresponding to the required fire resistance period.
- Cladding of the opening reveal: A surrounding reveal (frame flush with the wall surface) shall be fitted in the opening in accordance with the layout of the respective wall lining (for walls without internal insulation) or made of at least 12.5 mm thick cementitious or gypsum bound sheets with fire reaction class A1 per EN 13501-1 (e.g. gypsum fibre or calcium silicate plates) (for walls with internal insulation).

Rigid floors

- of masonry, concrete, reinforced concrete or aerated concrete
- density $\geq 630 \text{ kg/m}^3$
- thickness $\geq 150 \text{ mm}$
- The floors shall be classified according to EN 13501-2 (maximum EI 60) corresponding to the required fire resistance period.

Note: This ETA does not cover the installation of the seal in special walls, i.e. in sandwich panel constructions.

"HENSOMASTIK Kombi-Schottsystem"

APPENDIX 2 – FIELD OF APPLICATION

Walls and floors

Annex 8

English translation prepared by DIBt

General

- The total permitted cross section of the installations (relative to the respective external dimensions; including cable support constructions) shall not exceed 60% of the opening.
- The distances between the individual services and between the services and the opening reveals shall comply with the specifications in the Annexes 2 and 5, depending on the type of services.
- For wall application the distance from the first support on both sides of the penetration seal shall be
 - ≤ 200 mm for cables, cable support constructions and metal pipes
 - ≤ 500 mm for plastic pipes

The main components of the brackets shall consist of materials with a fire reaction class A1 or A2 in accordance with EN 13501-1.

Type of installations

Typ	Description
Cables	<ul style="list-style-type: none"> ➤ All types of sheathed cables* currently and commonly used in building practice in Europe (e.g. power cables, data cables, telecommunications cables, fibre-optic cables) with the exception of waveguides ➤ $\varnothing \leq 80$ mm ➤ The cables may be grouped as layers and laid on cable support constructions ➤ Cable bundles – consisting of parallel cables, densely packed and tightly bound, stitched or welded to one another – may pass through the opening provided the external diameter of the individual cables in the bundle does not exceed 21 mm and the overall diameter of the cable bundle does not exceed 100 mm.
Cable support constructions	<ul style="list-style-type: none"> ➤ Perforated or unperforated cable trays and cable ladders made of steel, with organic coatings if required (provided the overall fire reaction class complies with at least class A2 per EN 13501-1)
Plastic pipes	<ul style="list-style-type: none"> ➤ Pipe group A: PE-HD pipes which comply with both EN 1519-1 and DIN 8074/8075 with dimensions (d_R, s) in accordance with Annex 10 ➤ Pipe group B: Pipes made of styrene copolymers called "Friaphon" by FRIATEC Aktiengesellschaft, 68229 Mannheim, Germany (Z-42.1-220) with dimensions (d_R, s) in accordance with Annex 10
Metal pipes	<ul style="list-style-type: none"> ➤ Steel, stainless steel, cast iron or copper pipes and other metals whose heat transfer capacity is lower than that of steel or copper and with a melting point $\geq 842^\circ\text{C}$ (EI 30) or $\geq 945^\circ\text{C}$ (EI 60) ➤ Pipe dimensions in accordance with Annex 11

* single or multicore cable with individual insulation of the cores and an additional protective covering of the assembly

"HENSOMASTIK Kombi-Schottsystem"

APPENDIX 2 – FIELD OF APPLICATION
Übersicht der Installationen

Annex 9

English translation prepared by DIBt

Fig. 1: Pipes of pipe group A (PE): wall and floor installation; fire resistance class EI 60-U/U

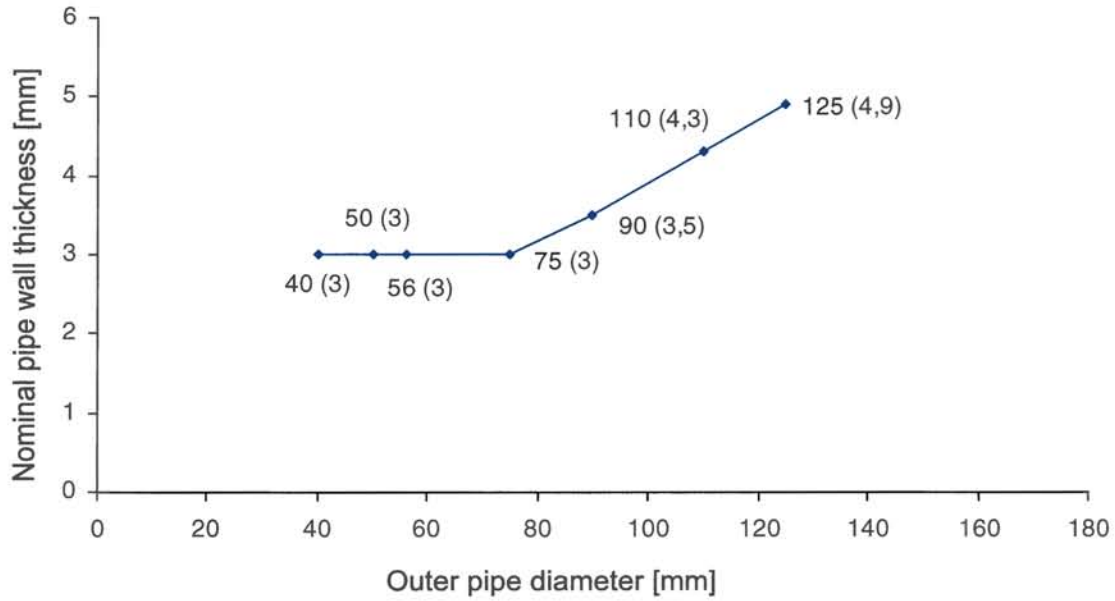
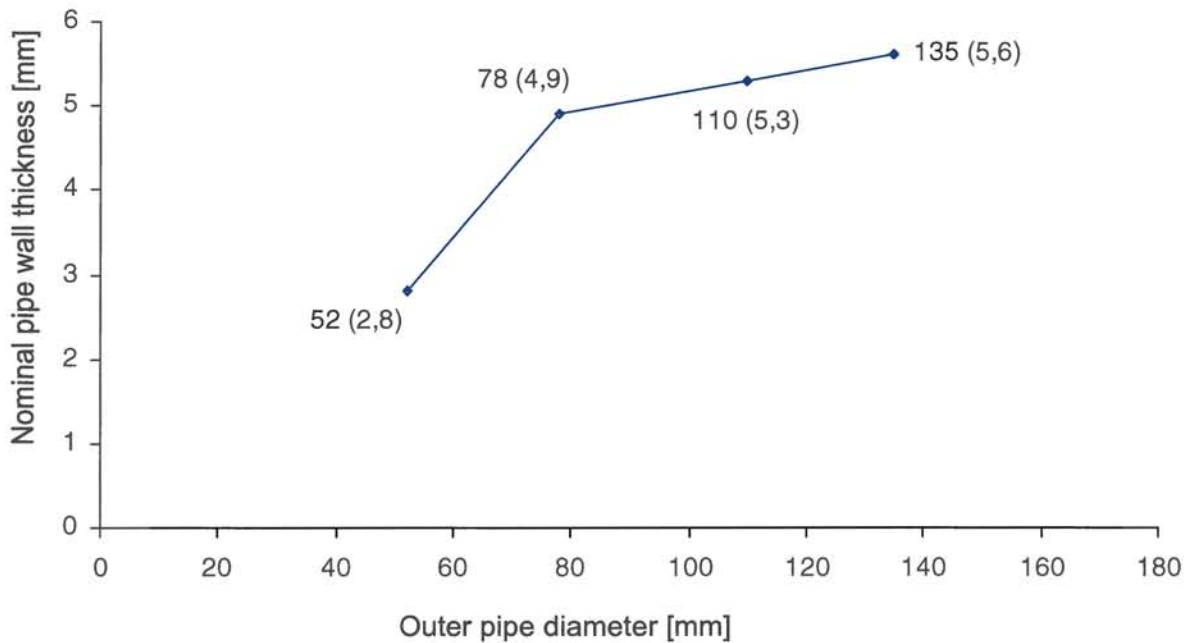

Fig. 2: Pipes of pipe group B ("Friaphon"): wall and floor installation; fire resistance class EI 60-U/U



"HENSOMASTIK Kombi-Schottsystem"

APPENDIX 2 – FIELD OF APPLICATION
Pipe dimensions for plastic pipes (pipe groups A and B)

Annex 10

English translation prepared by DIBt

Fig. 3: Steel, stainless steel, cast iron pipes (or equivalent, see Annex 9): wall and floor installation; fire resistance class EI 60-U/C

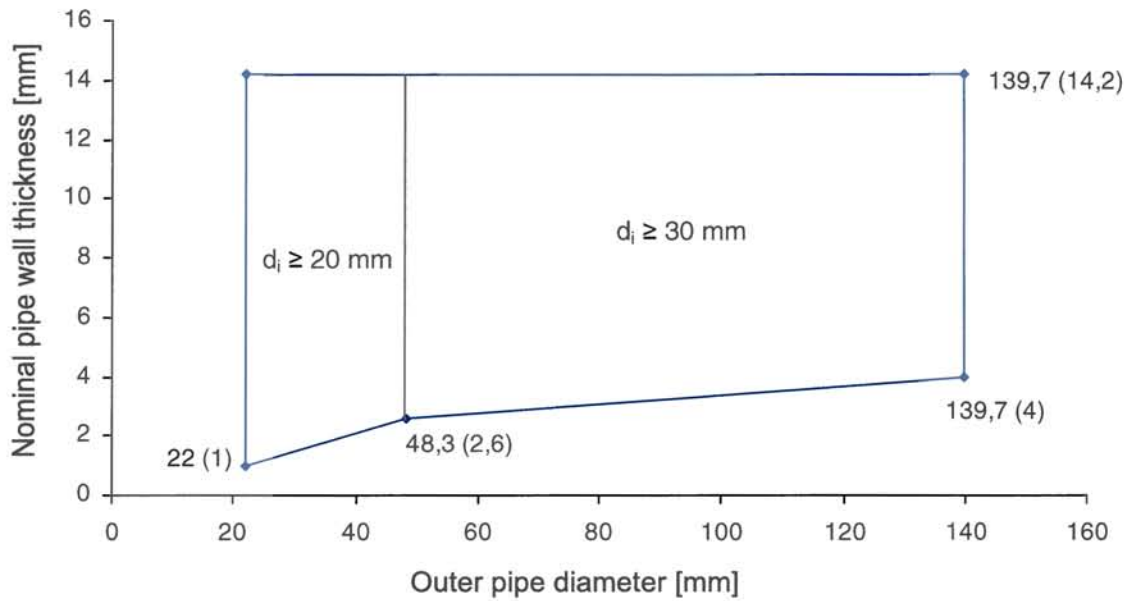
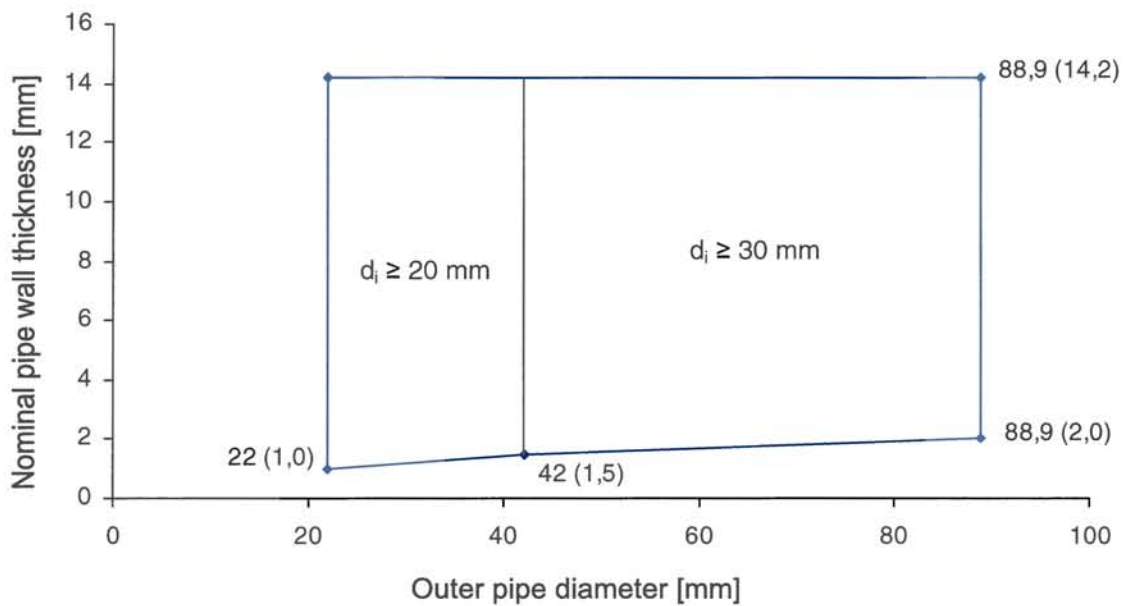

Fig. 4: copper pipes (or equivalent, see Annex 9): wall and floor installation; fire resistance class EI 60-U/C



d_i = thickness of the local insulation

"HENSOMASTIK Kombi-Schottsystem"

APPENDIX 2 – FIELD OF APPLICATION
Pipe dimensions for metal pipes

Annex 11

INSTALLATION OF THE PENETRATION SEAL

1. General

- 1.1 Before installing the mixed penetration seals, all framework conditions are to be checked for compliance (e.g. type and thickness of the wall, type and dimensions of the cables and the ambient conditions) with the provisions of section 1.2 and Appendices 1 and 2.
- 1.2 It shall be ensured that the assumptions under which the fitness for use was evaluated are complied with (see section 4).

2. Installation of the mineral fibre board plain

- 2.1 The mineral fibre boards shall be cut into individual pieces which are to be installed in one plain such that they sit tightly and fit precisely into all openings between the pipes and between the pipes and the reveal of the opening. The mineral fibre board pieces shall be installed such that all openings are mostly sealed (see Appendix 1). Up to 10 mm wide joints surrounding the pipes may remain unclosed.
- 2.2 The mineral fibre board plain shall be inset at least 20 mm into the wall on both sides (see Annex 3). For floor installation, the mineral fibre board plain can be installed flush with the upper or lower side of the floor. Installation positions in between are permitted (see Annex 6).
- 2.3 All remaining gaps, joints and spaces - in particular between the individual cables – shall be spray-filled with the ablative material "HENSOMASTIK 5 KS SP" from both sides to a depth of at least 60 mm to seal the remaining unclosed space. Cable bundles in accordance with Annex 9 do not have to be filled with material.
- 2.4 The mineral fibre board plain shall be coated with an at least 1 mm thick layer (dry layer thickness) of "HENSOMASTIK 5KS" (see Annexes 3 and 6).

The transition area (butt joint) between the mineral fibre board plain and the adjacent component shall be coated at least 1 mm thick (dry layer thickness) with "HENSOMASTIK 5 KS" or "HENSOMASTIK 5 KS viskos" so that the layer extends at least 20 mm beyond the penetration seal surface (on the component reveal or the component surface) (see Annexes 3 and 6).

3. Measures on the cables and cable support constructions

- 3.1 The cables and cable support constructions shall be coated with an at least 1 mm thick layer (dry layer thickness) of "HENSOMASTIK 5KS" on both sides of the mineral fibre board plain. The length of the coating shall comply with the specifications in Annex 3 and 6.
- 3.2 If for floor installation a fire resistance class EI 60 is required, cables with a diameter ≥ 21 mm shall be coated with an additional 1 mm thick layer of the intumescent material at a length of minimum 30 mm on both sides of the seal (see Annex 6).

4. Measures on the plastic pipes

- 4.1 For pipe penetrations in floors, one "AWM II Light" pipe collar shall be fixed at the underside of the mineral fibre board plain, and for pipe penetrations in walls on each side of the mineral fibre board plain one pipe collar shall be fixed. The smallest pipe collar in accordance with ETA-11/0208 assigned to the relevant external pipe diameter shall be used. This ETA does not address special penetrations – e.g. obliquely penetrations, oversized penetrations or multiple penetrations of pipes through one pipe collar.
- 4.2 The pipe collars shall be fixed to the mineral fibre board plain via their lugs with threaded bolts (diameter 6 mm) reaching trough the mineral fibre boards (see Annexes 2, 4, 5 and 7).
For floor installation, washers (diameter 40 mm) shall be fitted at the top of the mineral fibre board plain. For wall installation, opposing collars are fixed with the same threaded bolts.
- 4.3 Adjacent collars may be in contact with one another (linear arrangement; no clusters).

"HENSOMASTIK Kombi-Schottsystem"

APPENDIX 3 – INSTALLATION OF THE PENETRATION SEAL

Annex 12

English translation prepared by DIBt

5. Measures on the metal pipes

- 5.1 At least 1000 mm long local insulations made of "Rockwool 800" pipe shells shall be fitted to the metal pipes on both sides of and in contact with the mineral fibre board layer. The thickness of the insulation shall fulfil the specifications in Annex 11 depending on the pipe material and the pipe dimensions. For floor installation, the local insulation on the underside of the floor shall be secured to prevent slippage.
- 5.2 The local insulation shall be secured with straps or wire (diameter ≥ 0.6 mm) in accordance with Appendix 1. The distance of the attachments shall be ≤ 200 mm (see Annexes 4 and 7).

"HENSOMASTIK Kombi-Schottsystem"

APPENDIX 3 – INSTALLATION OF THE PENETRATION SEAL

Annex 13

English translation prepared by DIBt

 XXXX
Rudolf Hensel GmbH, Lauenburger Landstraße 11 21039 Börnsen, DEUTSCHLAND/GERMANY
11
XXXX-CPD-XXXX
ETA-11/0209 ETAG 026 – Teil 2/Part 2 Kombiabschottung/ Mixed Penetration Seal "HENSOMASTIK Kombi- Schottsystem" Ablative Komponente/ ablative component "HENSOMASTIK 5 KS" Nutzungskategorie/ use category X

"CE"-Zeichen / "CE" marking

Identifizierungsnummer der notifizierten Stelle (für Konformitätsbescheinigungssystem 1) / Identification number of notified certification body

Name und Anschrift des Herstellers oder seines autorisierten Vertreters (verantwortliche juristische Person) / Name and address of the producer (legal entity responsible for the manufacturer)

Die letzten beiden Ziffern des Jahres, in dem die CE-Kennzeichnung angebracht wurde / Two last digits of year of affixing CE marking

Nummer des EG-Konformitätszertifikats / Number of EC certificate of conformity

Nummer der ETA / ETA number

Nummer der Leitlinie / ETAG number

Produktbezeichnung (Handelsname) / Designation of the product (trade name)

Produktbezeichnung der Komponente (Handelsname) / Designation of the component (trade name)

Nutzungskategorie / use category

Für weitere relevante Produktmerkmale (z. B. Feuerwiderstandsklasse, Abgabe gefährlicher Stoffe) s. ETA-11/0209/ See ETA-11/0209 for other relevant characteristics (i.e. fire resistance class, dangerous substances)

"HENSOMASTIK Kombi-Schottsystem"

APPENDIX 4 – EXAMPLE FOR CE MARKING AND ADDITIONAL INFORMATION

Annex 14

English translation prepared by DIBt

Abbreviations

- FWKL:** maximum fire resistance class; If installed in building elements of the same type, thickness, density and with the same structure, but with a lower fire resistance class, the fire resistance class of the penetration seal is reduced to the fire resistance class of the building element.
- LTW:** flexible wall according to annex 8
- MW:** rigid wall according to annex 8
- D:** rigid floor according to annex 8
- d_w:** wall thickness
- d_D:** floor thickness
- d_A:** outer pipe diameter (nominal diameter according to the standards)
- d_i:** thickness of the local insulation
- s:** pipe wall thickness (nominal value according to the standards)
- ∅:** external diameter
- U/U:** pipe end configuration "uncapped/uncapped" (on both sides open pipe ends in the fire test)
- U/C:** pipe end configuration "uncapped/capped" (on the fire side open pipe ends and on the cold side capped pipe ends in the fire test)

Standards

- EN 13501-2:2010-02** Fire classification of construction products and building elements – Part 2: Classification using test data from resistance to fire tests, excluding ventilation services
- EN 13501-1:2007** Fire classification of construction products and building elements – Part 1: Classification using test data from reaction to fire tests
- prEN 1366-3: 07/2007** Document from CEN TC 127 for formal vote (document N 185); title see EN 1366-3: 2009-07
- EN 1366-3: 2009-07** Fire resistance tests for service installations – Part 3: Penetration seals
- EN 13162: 2008** Thermal insulation products for buildings - Factory made mineral wool (MW) products – Specification

Other documents

- ETAG 026-2** Guideline for European Technical Approval of Fire Stopping and Fire Sealing Products, Part 2, Penetration Seals (edition January 2008)
- EOTA TR 024** Characterisation, Aspects of Durability and Factory Production Control for Reactive Materials, Components and Products (edition November 2006)

"HENSOMASTIK Kombi-Schottsystem"

APPENDIX 5 – ABBREVIATIONS AND REFERENCE DOCUMENTS

Annex 15