



European Technical Approval ETA-11/0244

English translation prepared by DIBt - Original version in German language

Handelsbezeichnung <i>Trade name</i>	BTI Verbundtechnik UVT 390 Top-Z <i>BTI compound mortar UVT 390 Top-Z</i>
Zulassungsinhaber <i>Holder of approval</i>	BTI Befestigungstechnik GmbH & Co. KG Salzstraße 51 74653 Ingelfingen DEUTSCHLAND
Zulassungsgegenstand und Verwendungszweck <i>Generic type and use of construction product</i>	Verbunddübel in den Größen Ø 8 mm bis Ø 40 mm zur Verankerung im Beton <i>Bonded anchor in the size of Ø 8 mm to Ø 40 mm for use in concrete</i>
Geltungsdauer: <i>Validity:</i>	vom <i>from</i> bis <i>to</i> 30 June 2011 16 February 2015
Herstellwerke <i>Manufacturing plants</i>	BTI Herstellwerk 1 BTI manufacturing plant 1

Diese Zulassung umfasst
This Approval contains

26 Seiten einschließlich 17 Anhänge
26 pages including 17 annexes

I LEGAL BASES AND GENERAL CONDITIONS

- 1 This European technical approval is issued by Deutsches Institut für Bautechnik in accordance with:
 - Council Directive 89/106/EEC of 21 December 1988 on the approximation of laws, regulations and administrative provisions of Member States relating to construction products¹, modified by Council Directive 93/68/EEC² and Regulation (EC) N° 1882/2003 of the European Parliament and of the Council³;
 - Gesetz über das In-Verkehr-Bringen von und den freien Warenverkehr mit Bauprodukten zur Umsetzung der Richtlinie 89/106/EWG des Rates vom 21. Dezember 1988 zur Angleichung der Rechts- und Verwaltungsvorschriften der Mitgliedstaaten über Bauprodukte und anderer Rechtsakte der Europäischen Gemeinschaften (Bauproduktengesetz - BauPG) vom 28. April 1998⁴, as amended by law of 31 October 2006⁵;
 - Common Procedural Rules for Requesting, Preparing and the Granting of European technical approvals set out in the Annex to Commission Decision 94/23/EC⁶;
 - Guideline for European technical approval of "Metal anchors for use in concrete - Part 5: Bonded anchors", ETAG 001-05.
- 2 Deutsches Institut für Bautechnik is authorized to check whether the provisions of this European technical approval are met. Checking may take place in the manufacturing plant. Nevertheless, the responsibility for the conformity of the products to the European technical approval and for their fitness for the intended use remains with the holder of the European technical approval.
- 3 This European technical approval is not to be transferred to manufacturers or agents of manufacturers other than those indicated on page 1, or manufacturing plants other than those indicated on page 1 of this European technical approval.
- 4 This European technical approval may be withdrawn by Deutsches Institut für Bautechnik, in particular pursuant to information by the Commission according to Article 5(1) of Council Directive 89/106/EEC.
- 5 Reproduction of this European technical approval including transmission by electronic means shall be in full. However, partial reproduction can be made with the written consent of Deutsches Institut für Bautechnik. In this case partial reproduction has to be designated as such. Texts and drawings of advertising brochures shall not contradict or misuse the European technical approval.
- 6 The European technical approval is issued by the approval body in its official language. This version corresponds fully to the version circulated within EOTA. Translations into other languages have to be designated as such.

¹ Official Journal of the European Communities L 40, 11 February 1989, p. 12
² Official Journal of the European Communities L 220, 30 August 1993, p. 1
³ Official Journal of the European Union L 284, 31 October 2003, p. 25
⁴ *Bundesgesetzblatt Teil I* 1998, p. 812
⁵ *Bundesgesetzblatt Teil I* 2006, p. 2407, 2416
⁶ Official Journal of the European Communities L 17, 20 January 1994, p. 34

II SPECIFIC CONDITIONS OF THE EUROPEAN TECHNICAL APPROVAL

1 Definition of product and intended use

1.1 Definition of the construction product

The BTI compound mortar UVT 390 Top-Z is a bonded anchor consisting of a cartridge with injection mortar UVT 390 Top-Z and a steel element. The steel elements are either

- anchor rods UVT Top A in the range of M8 to M30 or
- internal threaded anchor UVT Top I in the range of M8 to M20 or
- Reinforcing bar in the range of \varnothing 8 to \varnothing 40 or
- BTI rebar anchor FRA in the range of 12 to 24.

The steel element is placed into a drilled hole filled with injection mortar and is anchored via the bond between metal part, injection mortar and concrete.

An illustration of the product and intended use is given in Annexes 1 and 2.

1.2 Intended use

The anchor is intended to be used for anchorages for which requirements for mechanical resistance and stability and safety in use in the sense of the Essential Requirements 1 and 4 of Council Directive 89/106 EEC shall be fulfilled and failure of anchorages made with these products would cause risk to human life and/or lead to considerable economic consequences. Safety in case of fire (Essential Requirement 2) is not covered in this European technical approval. The anchor is to be used only for anchorages subject to static or quasi-static loading in reinforced or unreinforced normal weight concrete of strength classes C20/25 at minimum and C50/60 at most according to EN 206:2000-12.

The anchor may be used in cracked or non-cracked concrete.

The anchor may be installed in dry or wet concrete.

The anchor may be used in the following temperature ranges:

Temperature range I:	-40 °C to +60 °C	(max long term temperature +35 °C and max short term temperature +60 °C)
Temperature range II:	-40 °C to +72 °C	(max long term temperature +50 °C and max short term temperature +72 °C)

Elements made of zinc coated steel:

The element made of zinc plated or hot dipped galvanised steel may only be used in structures subject to dry internal conditions.

Elements made of stainless steel:

The element made of stainless steel may be used in structures subject to dry internal conditions and also in structures subject to external atmospheric exposure (including industrial and marine environment), or exposure to permanently damp internal conditions, if no particular aggressive conditions exist. Such particular aggressive conditions are e.g. permanent, alternating immersion in seawater or the splash zone of seawater, chloride atmosphere of indoor swimming pools or atmosphere with extreme chemical pollution (e.g. in desulphurization plants or road tunnels where de-icing materials are used).

Elements made of high corrosion resistant steel:

The element made of high corrosion resistant steel may be used in structures subject to dry internal conditions and also in structures subject to external atmospheric exposure, in permanently damp internal conditions or in other particular aggressive conditions. Such particular aggressive conditions are e. g. permanent, alternating immersion in seawater or the splash zone of seawater, chloride atmosphere of indoor swimming pools or atmosphere with chemical pollution (e.g. in desulphurization plants or road tunnels where de-icing materials are used).

Elements made of reinforcing bars:

Post-installed reinforcing bars may be used as anchor designed in accordance with the EOTA Technical Report TR 029 only. Such applications are e.g. concrete overlay or shear dowel connections or the connections of a wall predominantly loaded by shear and compression forces with the foundation, where the reinforcing bars act as dowels to take up shear forces. Connections with post-installed reinforcing bars in concrete structures designed in accordance with EN1992-1-1: 2004 are not covered by this European technical approval.

The provisions made in this European technical approval are based on an assumed working life of the anchor of 50 years. The indications given on the working life cannot be interpreted as a guarantee given by the producer, but are to be regarded only as a means for choosing the right products in relation to the expected economically reasonable working life of the works.

2 Characteristics of the product and methods of verification

2.1 Characteristics of the product

The anchor corresponds to the drawings and provisions given in Annexes 1 to 7. The characteristic material values, dimensions and tolerances of the anchor not indicated in Annex 1 to 7 shall correspond to the respective values laid down in the technical documentation⁷ of this European technical approval.

The characteristic values for the design of anchorages are given in Annexes 10 to 17.

The two components of the injection mortar are delivered in unmixed condition in side-by-side-cartridges of sizes 390 ml, 585 ml or 1100 ml according to Annex 1. Each cartridge is marked with the imprint "UVT 390 Top-Z", with processing notes, shelf life, curing time, processing time (depending on temperature), hazard code.

Each anchor rod UVT Top A rod is marked with the identifying mark of the producer and property class in accordance with Annex 3.

Each internal threaded anchor UVT Top I is marked with the marking of steel grade and length in accordance with Annex 4. Each internal threaded anchor UVT Top I made of stainless steel is marked with the additional letter "A4". Each internal threaded anchor UVT Top I made of high corrosion resistant steel is marked with the additional letter "C".

Each BTI rebar anchor FRA is marked with the identifying mark of the producer and the trade name according to Annex 7.

Elements made of reinforcing bars shall comply with the specifications given in Annex 6.

The marking of embedment depth may be done on jobsite.

⁷ The technical documentation of this European technical approval is deposited at the Deutsches Institut für Bautechnik and, as far as relevant for the tasks of the approved bodies involved in the attestation of conformity procedure, is handed over to the approved bodies.

2.2 Methods of verification

The assessment of fitness of the anchor for the intended use in relation to the requirements for mechanical resistance and stability and safety in use in the sense of the Essential Requirements 1 and 4 has been made in accordance with the "Guideline for European technical approval of Metal Anchors for Use in Concrete", Part 1 "Anchors in general" and Part 5 "Bonded anchors", on the basis of Option 1.

In addition to the specific clauses relating to dangerous substances contained in this European technical approval, there may be other requirements applicable to the products falling within its scope (e.g. transposed European legislation and national laws, regulations and administrative provisions). In order to meet the provisions of the Construction Products Directive, these requirements need also to be complied with, when and where they apply.

3 Evaluation and attestation of conformity and CE marking

3.1 System of attestation of conformity

According to the Decision 96/582/EG of the European Commission⁸ system 2(i) (referred to as System 1) of the attestation of conformity applies.

This system of attestation of conformity is defined as follows:

System 1: Certification of the conformity of the product by an approved certification body on the basis of:

- (a) Tasks for the manufacturer:
 - (1) factory production control;
 - (2) further testing of samples taken at the factory by the manufacturer in accordance with a prescribed control plan;
- (b) Tasks for the approved body:
 - (3) initial type-testing of the product;
 - (4) initial inspection of factory and of factory production control;
 - (5) continuous surveillance, assessment and approval of factory production control.

Note: Approved bodies are also referred to as "notified bodies".

3.2 Responsibilities

3.2.1 Tasks for the manufacturer

3.2.1.1 Factory production control

The manufacturer shall exercise permanent internal control of production. All the elements, requirements and provisions adopted by the manufacturer shall be documented in a systematic manner in the form of written policies and procedures, including records of results performed. This production control system shall insure that the product is in conformity with this European technical approval.

The manufacturer may only use initial/raw/constituent materials stated in the technical documentation of this European technical approval.

⁸ Official Journal of the European Communities L 254 of 08.10.1996

The factory production control shall be in accordance with the control plan which is part of the technical documentation of this European technical approval. The control plan is laid down in the context of the factory production control system operated by the manufacturer and deposited at Deutsches Institut für Bautechnik.⁹

The results of factory production control shall be recorded and evaluated in accordance with the provisions of the control plan.

3.2.1.2 Other tasks for the manufacturer

The manufacturer shall, on the basis of a contract, involve a body which is approved for the tasks referred to in section 3.1 in the field of anchors in order to undertake the actions laid down in section 3.2.2 For this purpose, the control plan referred to in sections 3.2.1.1 and 3.2.2 shall be handed over by the manufacturer to the approved body involved.

The manufacturer shall make a declaration of conformity, stating that the construction product is in conformity with the provisions of this European technical approval.

3.2.2 Tasks for the approved bodies

The approved body shall perform the

- initial type-testing of the product,
 - initial inspection of factory and of factory production control,
 - continuous surveillance, assessment and approval of factory production control
- in accordance with the provisions laid down in the control plan.

The approved body shall retain the essential points of its actions referred to above and state the results obtained and conclusions drawn in a written report.

The approved certification body involved by the manufacturer shall issue an EC certificate of conformity of the product stating the conformity with the provisions of this European technical approval.

In cases where the provisions of the European technical approval and its control plan are no longer fulfilled the certification body shall withdraw the certificate of conformity and inform Deutsches Institut für Bautechnik without delay.

3.3 CE marking

The CE marking shall be affixed on each packaging of the anchor. The letters "CE" shall be followed by the identification number of the approved certification body, where relevant, and be accompanied by the following additional information:

- the name and address of the holder of the approval (legal entity responsible for the manufacture),
- the last two digits of the year in which the CE marking was affixed,
- the number of the EC certificate of conformity for the product,
- the number of the European technical approval,
- the number of the guideline for European technical approval,
- use category (ETAG 001-1, Option 1),
- size.

⁹ The control plan is a confidential part of the European technical approval and only handed over to the approved body involved in the procedure of attestation of conformity. See section 3.2.2.

4 Assumptions under which the fitness of the product for the intended use was favourably assessed

4.1 Manufacturing

The European technical approval is issued for the product on the basis of agreed data/information, deposited at Deutsches Institut für Bautechnik, which identifies the product that has been assessed and judged. Changes to the product or production process, which could result in this deposited data/information being incorrect, should be notified to Deutsches Institut für Bautechnik before the changes are introduced. Deutsches Institut für Bautechnik will decide whether or not such changes affect the approval and consequently the validity of the CE marking on the basis of the approval and if so whether further assessment or alterations to the approval shall be necessary.

4.2 Design of anchorages

The fitness of the anchor for the intended use is given under the following conditions:

The anchorages are designed in accordance with the EOTA Technical Report TR 029 "Design of bonded anchors"¹⁰ under the responsibility of an engineer experienced in anchorages and concrete work.

Post-installed reinforcing bars may be used as anchor designed in accordance with the EOTA Technical Report TR 029 only. The basic assumptions for the design according to anchor theory shall be observed. This includes the consideration of tension and shear loads and the corresponding failure modes as well as the assumption that the base material (concrete structural element) remains essentially in the serviceability limit state (either non-cracked or cracked) when the connection is loaded to failure. Such applications are e.g. concrete overlay or shear dowel connections or the connections of a wall predominantly loaded by shear and compression forces with the foundation, where the reinforcing bars act as dowels to take up shear forces. Connections with reinforcing bars in concrete structures designed in accordance with EN 1992-1-1:2004 (e.g. connection of a wall loaded with tension forces in one layer of the reinforcement with the foundation) are not covered by this European technical approval.

Anchor rods UVT Top A may be replaced by commercial standard threaded rods, washers and hexagon nuts made of galvanised steel or stainless steel if the following requirements are fulfilled:

- material, dimensions and mechanical properties of the metal parts according to the specifications given in Annex 5, Table 3,
- confirmation of material and mechanical properties of the metal parts by inspection certificate 3.1 according to EN 10204:2004, the documents should be stored,
- marking of the threaded rod with the envisage embedment depth. This may be done by the manufacturer of the rod or the person on jobsite.

For the internal threaded anchor UVT Top I fastening screws or threaded rods made of appropriate steel and strength class acc. to Annex 5 shall be specified. The minimum and maximum thread engagement length l_E of the fastening screw or the threaded rod for installation of the fixture shall be met the requirements according to Annex 4, Table 2. The length of the fastening screw or the threaded rod shall be determined depending on thickness of fixture, admissible tolerances, available thread length and minimum and maximum thread engagement length l_E .

¹⁰ The Technical Report TR 029 "Design of bonded anchors" is published in English on EOTA website www.eota.eu.

Verifiable calculation notes and drawings are prepared taking account of the loads to be anchored.

The position of the anchor is indicated on the design drawings (e.g. position of the anchor relative to reinforcement or to supports, etc.).

4.3 Installation of anchors

The fitness for use of the anchor can only be assumed if the anchor is installed as follows:

- anchor installation carried out by appropriately qualified personnel and under the supervision of the person responsible for technical matters of the site,
- anchor installation in accordance with the manufacturer's specifications and drawings using the tools indicated in the technical documentation of this European technical approval,
- use of the anchor only as supplied by the manufacturer without exchanging the components,
- reinforcing bars shall comply with specifications given in Annex 6,
- checks before placing the anchor to ensure that the strength class of the concrete in which the anchor is to be placed is in the range given and is not lower than that of the concrete to which the characteristic loads apply,
- check of concrete being well compacted, e.g. without significant voids,
- marking and keeping the effective anchorage depth,
- edge distance and spacing not less than the specified values without minus tolerances,
- positioning of the drill holes without damaging the reinforcement,
- drilling by hammer-drilling,
- in case of aborted drill hole: the drill hole shall be filled with mortar,
- cleaning the drill hole and installation in accordance with Annexes 8 and 9,
- during installation and curing of the chemical mortar the anchor component installation temperature shall be at least 5 °C;
- during curing of the chemical mortar the temperature of the concrete must not fall below +5 °C; observing the curing time according to Annex 5, Table 4 until the anchor may be loaded,
- for installation in bore holes $h_0 > 150$ mm extension hoses acc. Annex 1 shall be used,
- for overhead installation or in bore hole depth $h_0 > 250$ mm injection-funnels acc. to Annex 1 shall be used,
- Fastening screw or threaded rods (including nut and washer) must comply with the appropriate material and strength class of the internal threaded anchor UVT Top I,
- installation torque moments are not required for functioning of the anchor. However, the torque moments given in Annex 3 to 7 must not be exceeded.

5 Indications to the manufacturer

5.1 Responsibility of the manufacturer

The manufacturer is responsible to ensure that the information on the specific conditions according to 1 and 2 including Annexes referred to as well as sections 4.2 and 4.3 is given to those who are concerned. This information may be made by reproduction of the respective parts of the European technical approval.

In addition all installation data shall be shown clearly on the package and/or on an enclosed instruction sheet, preferably using illustration(s).

The minimum data required are:

- drill bit diameter,
- diameter of anchor rod,
- information on the installation procedure, including cleaning of the hole with the cleaning equipments, preferably by means of an illustration,
- anchor component installation temperature,
- ambient temperature of the concrete during installation of the anchor,
- admissible processing time (open time) of the mortar,
- curing time until the anchor may be loaded as a function of the ambient temperature in the concrete during installation,
- identification of the manufacturing batch,

All data shall be presented in a clear and explicit form.

5.2 Packaging, transport and storage

The cartridges shall be protected against sun radiation and shall be stored according to the manufacturer's installation instructions in dry condition at temperatures of at least +5 °C to not more than +30 °C.

Cartridges with expired shelf life must no longer be used.

The anchor shall only be packaged and supplied as a complete unit. Cartridges may be packed separately from metal parts.

Georg Feistel
Head of Department

beglaubigt:
Baderschneider

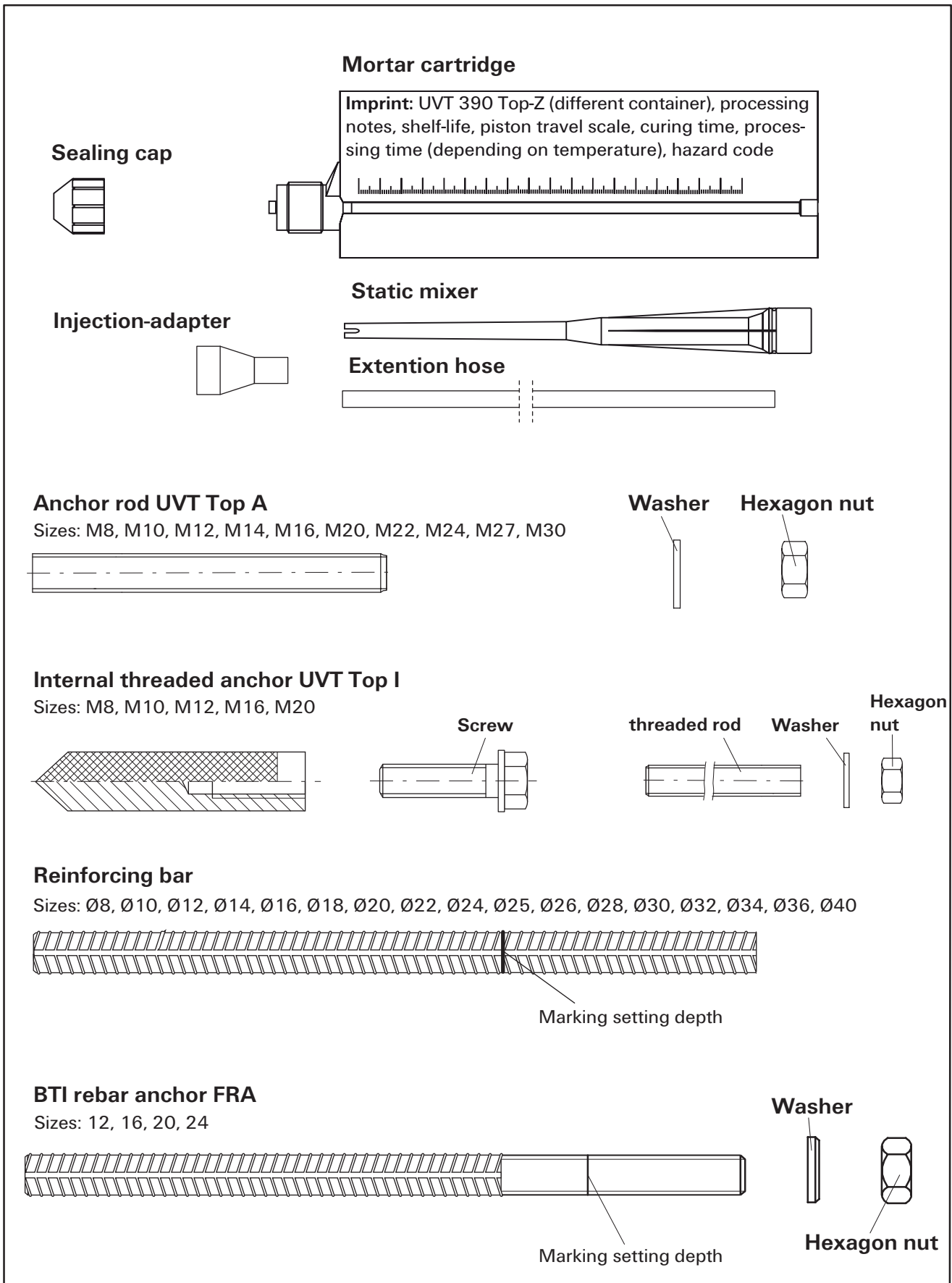

Doc: UVT-Top-Z-06-11

BTI compound mortar UVT 390 Top-Z	Annex 1 of European technical approval ETA-11/0244
Products	

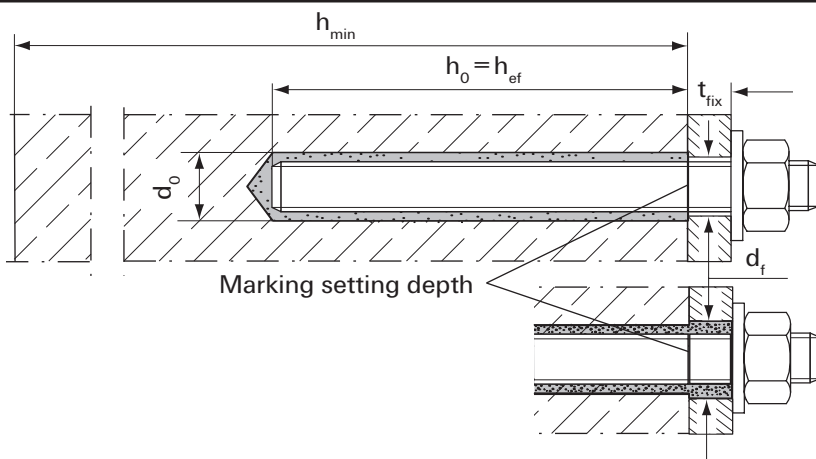

Anchor rod UVT Top A
Pre-positioned anchorage

In-place anchorage
(annual clearance filled with mortar)

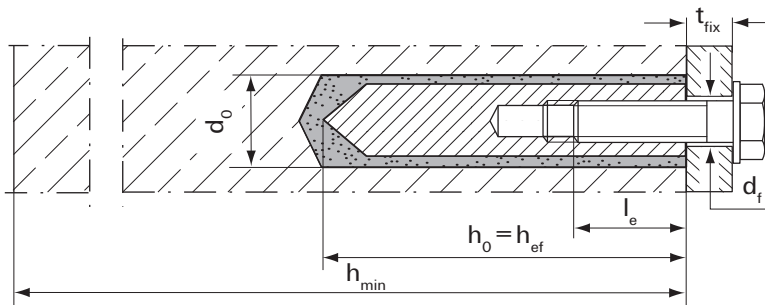

Internal threaded anchor UVT Top I
Only pre-positioned anchorage

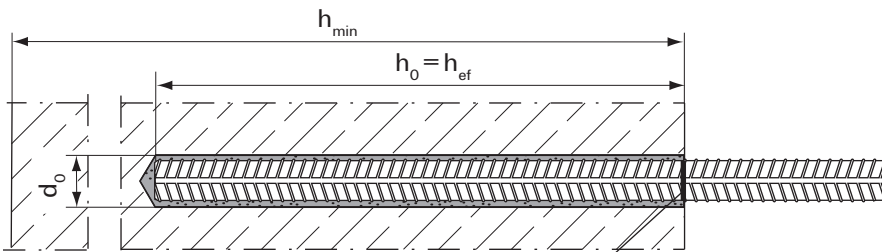

Reinforcing bar

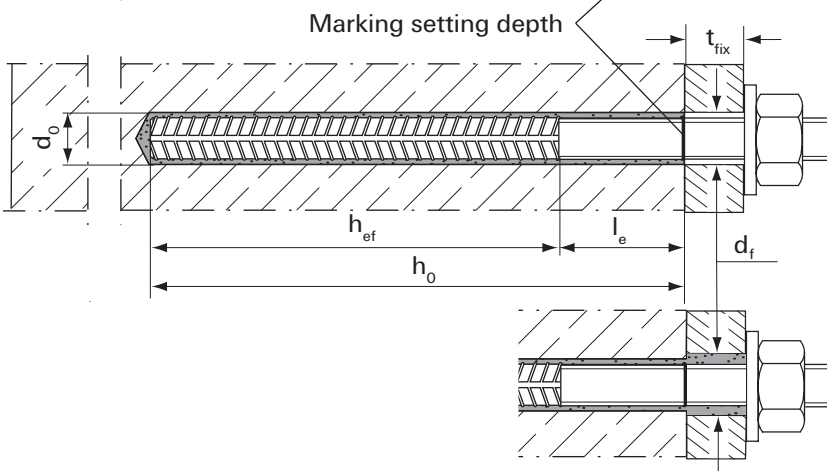

BTI rebar anchor FRA
Pre-positioned anchorage

In-place anchorage
(annual clearance filled with mortar)

Intended use in dry and wet concrete

Temperature range I: -40°C to +60°C (max. long term temperature +35°C and max. short term temperature +60°C)

Temperature range II: -40°C to +72°C (max. long term temperature +50°C and max. short term temperature +72°C)

BTI compound mortar UVT 390 Top-Z

Application range
Intended use

Annex 2

of European technical approval

ETA-11/0244

Table 1: Installation parameters anchor rods UVT Top A

Size of anchor		[-]	M8	M10	M12	M14	M16	M20	M22	M24	M27	M30
Nominal drill bit diameter	d_o	[mm]	12	14	14	16	18	24	25	28	30	35
Depth of drill hole	h_o	[mm]	$h_o = h_{ef}$									
Effective anchorage depth	$h_{ef,min}$	[mm]	60	60	70	75	80	90	93	96	108	120
	$h_{ef,max}$	[mm]	160	200	240	280	320	400	440	480	540	600
Minimum spacing and minimum edge distance	$s_{min} = c_{min}$	[mm]	40	45	55	60	65	85	95	105	120	140
Diameter of clearance hole in the fixture	pre-positioned anchorage	d_f	9	12	14	16	18	22	24	26	30	33
	in-place anchorage	d_f	14	16	16	18	20	26	28	30	33	40
Minimum thickness of concrete member	h_{min}	[mm]	$h_{ef} + 30 (\geq 100)$				$h_{ef} + 2d_o$					
Maximum torque moment	$T_{inst,max}$	[Nm]	10	20	40	50	60	120	135	150	200	300
Thickness of fixture	$t_{fix,min}$	[mm]	0									
	$t_{fix,max}$	[mm]	3000									

Anchor rod UVT Top A

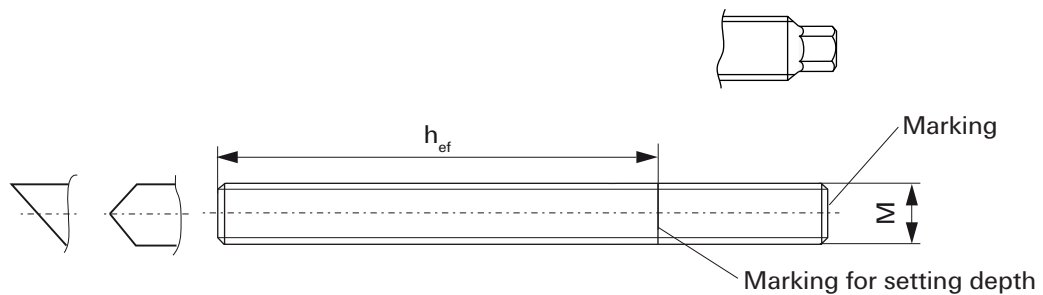

Marking:

- Property class 8.8 or high corrosion-resistant steel C, property class 80: •
- Stainless steel A4, property class 50 and high corrosion-resistant Steel C, property class 50: ••

BTI compound mortar UVT 390 Top-Z

Anchor rod UVT Top A
Installation parameters and dimensions

Annex 3

of European technical approval

ETA-11/0244

Table 2: Installation parameters internal threaded anchors UVT Top I

Size of anchor		M8	M10	M12	M16	M20
Diameter of anchor	d_H [mm]	12	16	18	22	28
Nominal drill bit diameter	d_o [mm]	14	18	20	24	32
Length of anchor	L_H [mm]	90	90	125	160	200
Effective anchorage depth h_{ef} and drill hole depth h_o	$h_{ef} = h_o$ [mm]	90	90	125	160	200
Minimum spacing and edge distance	$s_{min} = c_{min}$ [mm]	55	65	75	95	125
Diameter of clearance hole in the fixture	d_f [mm]	9	12	14	18	22
Minimum thickness of concrete member	h_{min} [mm]	120	125	165	205	260
Screw-in depth	$l_{E,min}$ [mm]	8	10	12	16	20
	$l_{E,max}$ [mm]	18	23	26	35	45
Maximum torque moment	$T_{inst,max}$ [Nm]	10	20	40	80	120

Internal threaded anchor UVT Top I

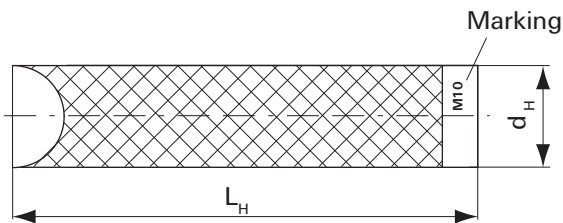
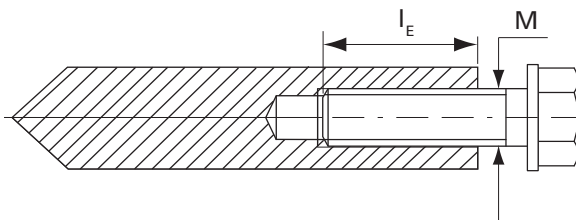

Marking: anchor size
 e.g.: **M10**
 Stainless steel additional A4
 e.g.: **M10 A4**
 High corrosion-resistant steel additional C
 e.g.: **M10 C**

BTI compound mortar UVT 390 Top-Z

Internal threaded anchors UVT Top I
 Installation parameters and dimensions

Annex 4

of European
 technical approval

ETA-11/0244

Table 3: Materials: anchor rods, threaded rods, washers, hexagon nuts and screws

Designation	Materials		
	Steel, zinc plated	Stainless steel (A4)	high corrosion-resistant steel (C)
Anchor rod	Property class 5.8 or 8.8; EN ISO 898-1 zinc plated $\geq 5\mu\text{m}$, EN ISO 4042 A2K or hot-dip galvanised $\geq 45\mu\text{m}$, EN ISO 10684	Property class 50 or 70 EN ISO 3506, EN 10088 1.4401; 1.4404; 1.4578; 1.4571; 1.4439; 1.4362	Property class 50 or 80 EN ISO 3506, or $f_{uk} = 700\text{ N/mm}^2$ $f_{yk} = 560\text{ N/mm}^2$ EN 10088 1.4462; 1.4539; 1.4565; 1.4529; 1.4547
Washer EN ISO 7089	zinc plated $\geq 5\mu\text{m}$, EN ISO 4042 A2K or hot-dip galvanised $\geq 45\mu\text{m}$, EN ISO 10684	EN 10088 1.4401; 1.4404; 1.4578; 1.4571; 1.4439; 1.4362	EN 10088 1.4462; 1.4539; 1.4565; 1.4529; 1.4547
Hexagon nut according to EN 24032	Property class 5 or 8; EN 20898-2 zinc plated $\geq 5\mu\text{m}$, EN ISO 4042 A2K or hot-dip galvanised $\geq 45\mu\text{m}$, EN ISO 10684	Property class 50 or 70 EN ISO 3506, EN 10088 1.4401; 1.4404; 1.4578; 1.4571; 1.4439; 1.4362	Property class 50,70 or 80 EN ISO 3506, EN 10088 1.4462; 1.4539; 1.4565; 1.4529; 1.4547
Screw or threaded rods for internal-threaded anchors RG MI	Property class 5.8 or 8.8; EN ISO 898-1 zinc plated $\geq 5\mu\text{m}$, EN ISO 4042 A2K or hot-dip galvanised $\geq 45\mu\text{m}$, EN ISO 10684	Property class 70 EN ISO 3506, EN 10088 1.4401; 1.4404; 1.4578; 1.4571; 1.4439; 1.4362	Property class 70 EN ISO 3506, EN 10088 1.4462; 1.4539; 1.4565; 1.4529; 1.4547

Table 4: Maximum permissible processing times and minimum curing times

System temperature [°C]	Max. processing time [minutes]	Minimum curing time ¹⁾ [hours]
+5 to +10	120	40
$\geq +10$ to +20	30	18
$\geq +20$ to +30	14	10
$\geq +30$ to +40	7	5

¹⁾For wet concrete the curing time must be doubled.

BTI compound mortar UVT 390 Top-Z

Materials
Processing times, curing times

Annex 5

of European
technical approval

ETA-11/0244

Table 5: Installation parameters reinforcing bars

Nominal bar size	$\varnothing d$ [mm]	8	10	12	14	16	18	20	22	24	25	26	28	30	32	34	36	40	
Nominal drill bit diameter	d_0 [mm]	12	14	16	18	20	25	25	30	30	30	35	35	40	40	40	45	55	
Drill hole depth	h_0 [mm]	$h_0 = h_{ef}$																	
Effective anchorage depth	$h_{ef,min}$ [mm]	60	60	70	75	80	85	90	94	98	100	104	112	120	128	136	144	160	
	$h_{ef,max}$ [mm]	160	200	240	280	320	360	400	440	480	500	520	560	600	640	680	720	800	
Minimum spacing and minimum edge distance	$s_{min} = c_{min}$ [mm]	40	45	55	60	65	75	85	95	105	110	120	130	140	160	170	180	200	
Minimum thickness of concrete member	h_{min} [mm]	$h_{ef} + 30$ ≥ 100					$h_{ef} + 2d_0$												

Reinforcing bar

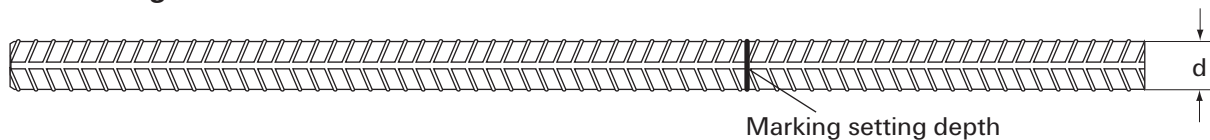

Refer to EN 1992-1-1 Annex C, Table C.1 and C.2N, properties of reinforcement:

Produkt form		Non-zinc-plated bars and de-coiled rod	
Class		B	C
Characteristic yield strength f_{yk} or $f_{0,2k}$ [MPa]		400 to 600	
Minimum value of $k = (f_t / f_{yk})$		$\geq 1,08$	$\geq 1,15$ < 1,35
Characteristic strain at maximum force, ϵ_{uk} [%]		$\geq 5,0$	$\geq 7,5$
Bendability		Bend / Rebind test	
Maximum deviation from nominal mass (individual bar) [%]	Nominal bar size [mm]		
	≤ 8 > 8	$\pm 6,0$ $\pm 4,5$	
Bond: Minimum relative rib area, $f_{R,min}$ (determination according to EN 15630)	Nominal bar size [mm]		
	8 to 12 > 12	0,040 0,056	

Rib height h:

The rib height h must be: $0,05 \cdot d \leq h \leq 0,07 \cdot d$ $d =$ nominal bar size

BTI compound mortar UVT 390 Top-Z

Reinforcing bars
Installation parameters
Materials

Annex 6

of European technical approval
ETA-11/0244

Table 6: Installation parameters BTI rebar anchors FRA

Threaded diameter		M 12	M 16	M 20	M 24
Nominal bar size	d [mm]	12	16	20	25
Nominal drill bit diameter	d ₀ [mm]	16	20	25	30
Depth of drill hole (h ₀ = l _{e,ges})	h ₀ [mm]	h _{ef} + l _e			
Effective anchorage depth	h _{ef,min} [mm]	70	80	90	96
	h _{ef,max} [mm]	140	220	300	380
Distance concrete surface to welded joint	l _e [mm]	100			
Minimum spacing and minimum edge distance	s _{min} = c _{min} [mm]	55	65	85	105
Diameter of clearance hole in the fixure	pre-positioned anchorage d _f [mm]	14	18	22	26
	in-place anchorage d _f [mm]	18	22	26	32
Minimum thickness of concrete member	h _{min} [mm]	h ₀ + 2d ₀			
Maximum torque moment	T _{inst,max} [Nm]	40	60	120	150
Thickness of fixure	minimum t _{fix} [Nm]	5			
	maximum t _{fix} [Nm]	3000			

BTI rebar anchor FRA

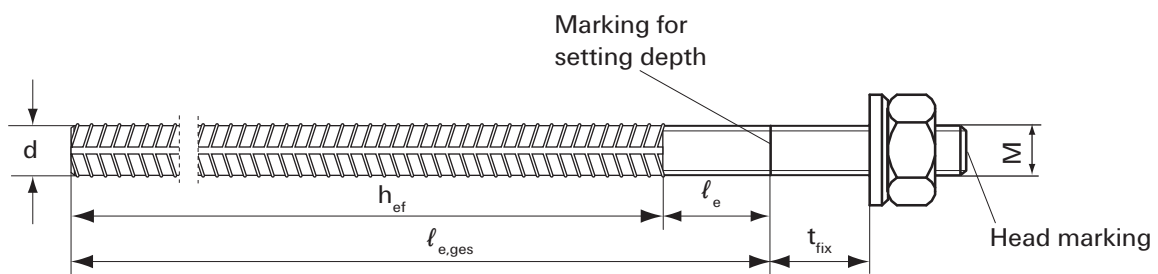







Head marking e.g.: FRA (for stainless steel)
 FRA C (for high corrosion-resistant steel)

BTI compound mortar UVT 390 Top-Z

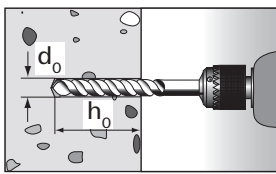
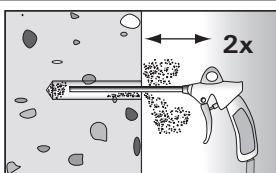
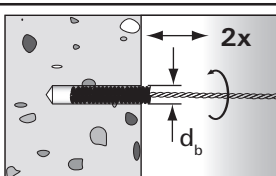
BTI rebar anchor FRA
 Installation Parameters

Annex 7
 of European
 technical approval
ETA-11/0244

Drilling and cleaning the hole

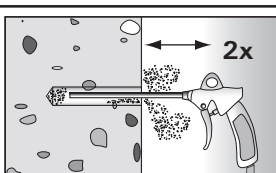
1		<p>Drill the hole. Drill hole diameter d_0 and drill hole depth h_0 see Tables 1, 2, 5 or 6.</p>																																
2		<p>Clean the drill hole. Blow out the drill hole two times, using oil-free pressure air ($P > 6$ bar).</p>																																
3		<p>Brush the drill hole two times, using a steel brush. For deep holes use an extension.</p> <table border="1" data-bbox="526 739 1420 828"> <tr> <td></td> <td>d_0 [mm]</td> <td>12</td> <td>14</td> <td>16</td> <td>18</td> <td>20</td> <td>24</td> <td>25</td> <td>28</td> <td>30</td> <td>32</td> <td>35</td> <td>40</td> <td>45</td> <td>55</td> </tr> <tr> <td></td> <td>d_b [mm]</td> <td>13</td> <td>16</td> <td>20</td> <td>21,5</td> <td>26</td> <td>27</td> <td>30</td> <td></td> <td>40</td> <td></td> <td>42</td> <td>47</td> <td>58</td> <td></td> </tr> </table>		d_0 [mm]	12	14	16	18	20	24	25	28	30	32	35	40	45	55		d_b [mm]	13	16	20	21,5	26	27	30		40		42	47	58	
	d_0 [mm]	12	14	16	18	20	24	25	28	30	32	35	40	45	55																			
	d_b [mm]	13	16	20	21,5	26	27	30		40		42	47	58																				
4		<p>Blow out the drill hole two times, using oil-free pressure air ($P > 6$ bar).</p>																																

Preparing the cartridge

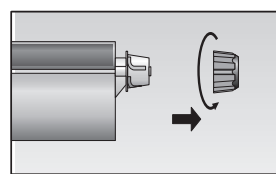
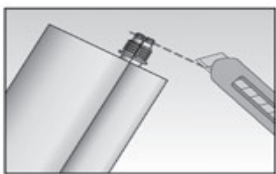
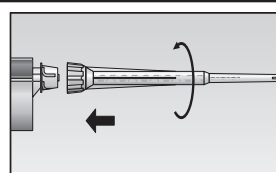
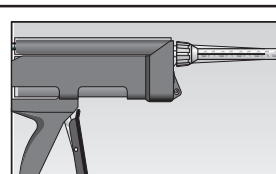
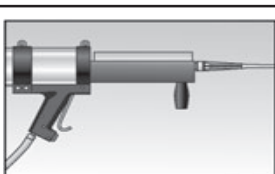
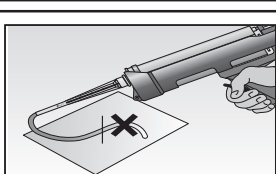
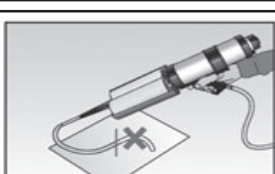
5		<p>Twist off the sealing cap. (Cartridge ≤ 600 ml)</p>		<p>Cut off the cap. (Cartridge 1100 ml)</p>
6		<p>Twist on the static mixer. (the spiral in the static mixer must be clearly visible)</p>		
7			<p>Place the cartridge into the applicator gun.</p>	
8			<p>Press approx 10 cm of material out until the resin is evenly grey in colour. Don't use mortar that is not uniformly gray.</p>	

BTI compound mortar UVT 390 Top-Z

Installation instructions
Part I

Annex 8

of European
Technical Approval
ETA-11/0244

Injection of the mortar

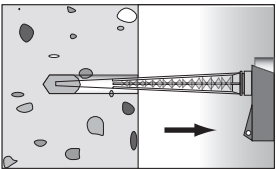
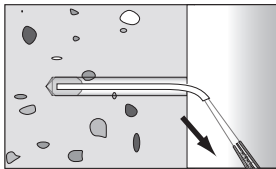
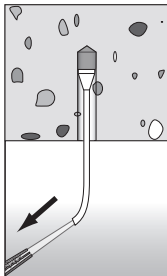
9	 <p>Fill approx. 2/3 of the drill hole with mortar. Always begin from the surface of the hole and avoid bubbles.</p>	 <p>For drill hole depth ≥ 150 mm use an extension hose.</p>	 <p>For overhead installation, deep holes $h_0 > 250$ mm or drill hole diameter $d_0 \geq 40$ mm use an injection-adaptor.</p>
----------	---	---	---

Installation anchor rods UVT Top A or internal threaded anchors UVT Top I

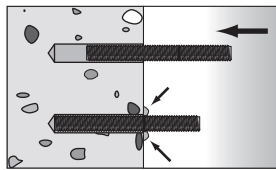
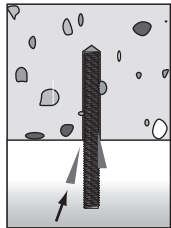
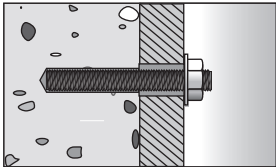
10	 <p>Only use clean and oil-free anchor elements. Mark the anchor for setting depth. Press the anchor rod or internal threaded anchor down to the bottom of the hole, turning it slightly while doing so. After inserting the anchor element, excess mortar must emerge from the mouth of the hole.</p>	 <p>For overhead installation support the anchor-rod with wedges.</p>	 <p>For in-place anchorage fill the annular clearance with mortar.</p>
-----------	---	---	--

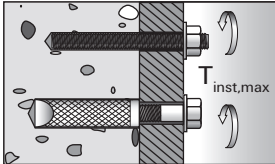
11	 <p>Wait for the specified curing time, t_{cure} see Table 4.</p>	 <p>Mounting the fixture. $T_{inst,max}$ see Table 1 or 2.</p>
-----------	---	---

Installation reinforcing bars and BTI rebar anchors FRA

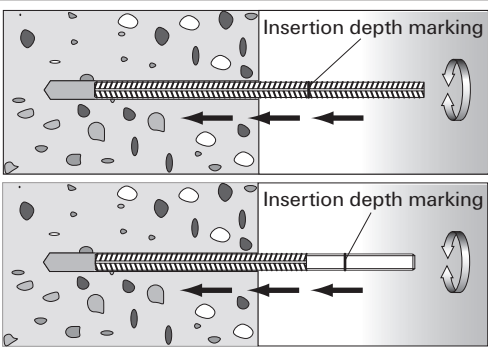
10	 <p>Insertion depth marking</p> <p>Only use clean and oil-free rebars. Mark the reinforcing bar for setting depth. Using a turning movement, push the reinforcement bar or the FRA vigorously into the filled hole up to the insertion depth marking.</p>
-----------	--

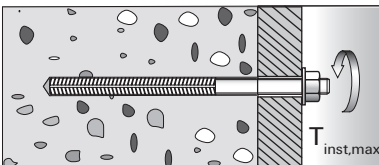
11	 <p>Wait for the specified curing time, t_{cure} see Table 4.</p>	 <p>Mounting the fixture. $T_{inst,max}$ see Table 6.</p>
-----------	---	--

BTI compound mortar UVT 390 Top-Z

Installation instructions
Part II

Annex 9

of European
technical approval

ETA-11/0244

Table 7: Characteristic values to tension load anchor rods UVT Top A

Size			M 8	M 10	M 12	M 14	M 16	M 20	M 22	M 24	M 27	M 30		
Steel failure														
Characteristic resistance $N_{Rk,s}$	Property class	5.8 [kN]	19	29	43	58	79	123	152	177	230	281		
		8.8 [kN]	30	47	68	92	126	196	243	282	368	449		
	stainless steel A4	Property class	50 [kN]	19	29	43	58	79	123	152	177	230	281	
			70 [kN]	26	41	59	81	110	172	212	247	322	393	
	high corrosion-resistant steel C	Property class	50 [kN]	19	29	43	58	79	123	152	177	230	281	
			70 ⁴⁾ [kN]	26	41	59	81	110	172	212	247	322	393	
		80 [kN]	30	47	68	92	126	196	243	282	368	449		
Partial safety factor $\gamma_{Ms,N}^{(1)}$	Property class	5.8 [-]							1,50					
		8.8 [-]							1,50					
	stainless steel A4	Property class	50 [-]							2,86				
			70 [-]							1,87				
	high corrosion-resistant steel C	Property class	50 [-]							2,86				
			70 ⁴⁾ [-]							1,50				
		80 [-]							1,60					
Combined pullout and concrete cone failure														
Diameter for calculation	d [mm]		8	10	12	14	16	20	22	24	27	30		
Characteristic bond resistance in non-cracked concrete C20/25														
Temperature range I (60°C / 35°C)	$\tau_{Rk,ucr}$ [N/mm ²]		16	15	15	14	14	13	13	13	13	12		
Temperature range II (72°C / 50°C)	$\tau_{Rk,ucr}$ [N/mm ²]		13	12	12	12	11	11	11	11	10	10		
Characteristic bond resistance in cracked concrete C20/25														
Temperature range I (60°C / 35°C)	$\tau_{Rk,cr}$ [N/mm ²]								7,0					
Temperature range II (72°C / 50°C)	$\tau_{Rk,cr}$ [N/mm ²]								6,0					
Increasing factors for τ_{Rk}	ψ_c	C25/30 [-]							1,02					
		C30/37 [-]							1,04					
		C35/45 [-]							1,06					
		C40/50 [-]							1,07					
		C45/55 [-]							1,08					
		C50/60 [-]							1,09					
Splitting failure														
Edge distance $c_{cr,sp}$ [mm]		$h / h_{ef} \geq 2,0$							$1,0 h_{ef}$					
		$2,0 > h / h_{ef} > 1,3$							$4,6 h_{ef} - 1,8 h$					
		$h / h_{ef} \leq 1,3$							$2,26 h_{ef}$					
Spacing	$s_{cr,sp}$ [mm]								$2c_{cr,sp}$					
Partial safety factor $\gamma_{Mp} = \gamma_{Mc} = \gamma_{Msp}^{(1)}$ [-]			1,5 ²⁾				1,8 ³⁾							
¹⁾ In absence of other national regulations. ²⁾ The partial safety factor $\gamma_2 = 1,0$ is included ³⁾ The partial safety factor $\gamma_2 = 1,2$ is included ⁴⁾ $f_{uk} = 700 \text{ N/mm}^2$; $f_{yk} = 560 \text{ N/mm}^2$														
BTI compound mortar UVT 390 Top-Z									Annex 10 of European technical approval ETA-11/0244					
Anchor rods UVT Top A Characteristic values to tension load														

Table 8: Characteristic values to shear load anchor rods UVT Top A

Size			M8	M10	M12	M14	M16	M20	M22	M24	M27	M30		
Steel failure without lever arm														
Characteristic resistance $V_{Rk,s}$	Property class	5.8 [kN]	9	15	21	29	39	61	76	89	115	141		
		8.8 [kN]	15	23	34	46	63	98	122	141	184	225		
	stainless steel A4	Property class	50 [kN]	9	15	21	29	39	61	76	89	115	141	
			70 [kN]	13	20	30	40	55	86	107	124	161	197	
	high corrosion-resistant steel C	Property class	50 [kN]	9	15	21	29	39	61	76	89	115	141	
			70 ³⁾ [kN]	13	20	30	40	55	86	107	124	161	197	
		80 [kN]	15	23	34	46	63	98	122	141	184	225		
Steel failure with lever arm														
Characteristic bending moment $M_{Rk,s}^0$	Property class	5.8 [Nm]	19	37	65	104	166	324	447	560	833	1123		
		8.8 [Nm]	30	60	105	167	266	519	716	896	1333	1797		
	stainless steel A4	Property class	50 [Nm]	19	37	65	104	166	324	447	560	833	1123	
			70 [Nm]	26	52	92	146	232	454	626	784	1167	1573	
	high corrosion-resistant steel C	Property class	50 [Nm]	19	37	65	104	166	324	447	560	833	1123	
			70 ³⁾ [Nm]	26	52	92	146	232	454	626	784	1167	1573	
		80 [Nm]	30	60	105	167	266	519	716	896	1333	1797		
Partial safety factor steel failure														
$\gamma_{Ms,V}^{1)}$	Property class	5.8 [-]							1,25					
		8.8 [-]							1,25					
	stainless steel A4	Property class	50 [-]							2,38				
			70 [-]							1,56				
	high corrosion-resistant steel C	Property class	50 [-]							2,38				
			70 ³⁾ [-]							1,25				
		80 [-]							1,33					
Concrete pryout failure														
Factor k in Equation (5.7) of Technical Report TR 029, Section 5.2.3.3			k [-]						2,00					
Partial safety factor			$\gamma_{Mcp}^{1)}$ [-]						1,5 ²⁾					
Concrete edge failure			See Technical Report TR 029, Section 5.2.3.4											
Partial safety factor			$\gamma_{Mc}^{1)}$ [-]						1,5 ²⁾					

¹⁾ In absence of other national regulations.

³⁾ $f_{uk} = 700 \text{ N/mm}^2$; $f_{yk} = 560 \text{ N/mm}^2$

²⁾ The partial safety factor $\gamma_2 = 1,0$ is included.

Table 9: Displacements of anchor rods UVT Top A to tension load

Size			M8	M10	M12	M14	M16	M20	M22	M24	M27	M30
Non-cracked concrete and cracked concrete; temperature range I to II												
Displacement	δ_{N0} [mm/(N/mm ²)]		0,07	0,08	0,09	0,09	0,10	0,11	0,11	0,12	0,12	0,13
Displacement	δ_{Nzc} [mm/(N/mm ²)]		0,11	0,12	0,13	0,14	0,15	0,16	0,17	0,18	0,19	0,19

Calculation of characteristic displacement with $\delta_N = (\delta_{N0} \cdot \tau_{sd}) / 1,4$

Table 10: Displacements of anchor rods UVT Top A to shear load

Size			M8	M10	M12	M14	M16	M20	M22	M24	M27	M30
Displacement	δ_{V0} [mm/kN]		0,18	0,15	0,12	0,10	0,09	0,07	0,07	0,06	0,05	0,05
Displacement	δ_{Vzc} [mm/kN]		0,27	0,22	0,18	0,16	0,14	0,11	0,10	0,09	0,08	0,07

Calculation of characteristic displacement with $\delta_V = (\delta_{V0} \cdot V_{sd}) / 1,4$

BTI compound mortar UVT 390 Top-Z

Anchor rods UVT Top A
Characteristic values to shear load
Displacements

Annex 11

of European
technical approval

ETA-11/0244

Table 11: Characteristic values to tension load internal threaded anchors UVT Top I

Size		M 8	M 10	M 12	M 16	M 20	
Steel failure							
Characteristic resistance with screw	$N_{Rk,s}$	Property 5.8 [kN]	19	29	43	79	123
		class 8.8 [kN]	29	47	68	108	179
		Property A4 [kN]	26	41	59	110	172
		class 70 C [kN]	26	41	59	110	172
Partial safety factor	$\gamma_{Ms,N}^{1)}$	Property 5.8 [-]	1,50				
		class 8.8 [-]	1,50				
		Property A4 [-]	1,87				
		class 70 C [-]	1,87				
Combined pullout and concrete cone failure							
Diameter for calculation	d_H [mm]	12	16	18	22	28	
Effective anchorage depth	h_{ef} [mm]	90	90	125	160	200	
Characteristic values in non-cracked concrete C20/25							
Temperature range I (60°C / 35°C) ⁴⁾	$N_{Rk,ucr}$ [kN]	50	60	95	140	200	
Temperature range II (72°C / 50°C) ⁴⁾	$N_{Rk,ucr}$ [kN]	40	50	75	115	170	
Characteristic values in cracked concrete C20/25							
Temperature range I (60°C / 35°C) ⁴⁾	$N_{Rk,cr}$ [kN]	20	30	50	75	115	
Temperature range II (72°C / 50°C) ⁴⁾	$N_{Rk,cr}$ [kN]	20	25	40	60	95	
Increasing factors for N_{Rk}	ψ_c	C25/30 [-]	1,02				
		C30/37 [-]	1,04				
		C35/45 [-]	1,06				
		C40/50 [-]	1,07				
		C45/55 [-]	1,08				
		C50/60 [-]	1,09				
Splitting failure							
Edge distance $c_{cr,sp}$ [mm]	$h / h_{ef} \geq 2,0$	$1,0 h_{ef}$					
	$2,0 > h / h_{ef} > 1,3$	$4,6 h_{ef} - 1,8 h$					
	$h / h_{ef} \leq 1,3$	$2,26 h_{ef}$					
Spacing	$s_{cr,sp}$ [mm]	$2c_{cr,sp}$					
Partial safety factor	$\gamma_{Mp} = \gamma_{Mc} = \gamma_{Msp}^{1)}$	1,5 ²⁾			1,8 ³⁾		

¹⁾ In absence of other national regulations.

²⁾ The partial safety factor $\gamma_2 = 1,0$ is included

³⁾ The partial safety factor $\gamma_2 = 1,2$ is included

⁴⁾ See annex 2

BTI compound mortar UVT 390 Top-Z

Internal threaded anchors UVT Top I
Characteristic values to tension load

Annex 12

of European
technical approval

ETA-11/0244

Table 12: Characteristic values to shear load internal threaded anchors UVT Top I

Size		M 8	M 10	M 12	M 16	M 20	
Steel failure without lever arm							
Characteristic resistance	$V_{Rk,s}$	Property class 5.8 [kN]	9,2	14,5	21,1	39,2	62
		Property class 8.8 [kN]	14,6	23,2	33,7	54,0	90
		Property class A4 [kN]	12,8	20,3	29,5	54,8	86
		Property class 70 C [kN]	12,8	20,3	29,5	54,8	86
Partial safety factor	$\gamma_{Ms,V}$	Property class 5.8 [-]	1,25				
		Property class 8.8 [-]	1,25				
		Property class A4 [-]	1,56				
		Property class 70 C [-]	1,56				
Steel failure with lever arm							
Characteristic bending moment	$M_{Rk,s}^0$	Property class 5.8 [Nm]	20	39	68	173	337
		Property class 8.8 [Nm]	30	60	105	266	519
		Property class A4 [Nm]	26	52	92	232	454
		Property class 70 C [Nm]	26	52	92	232	454
Partial safety factor	$\gamma_{Ms,V}$	Property class 5.8 [-]	1,25				
		Property class 8.8 [-]	1,25				
		Property class A4 [-]	1,56				
		Property class 70 C [-]	1,56				
Concrete pryout failure							
Factor k in Equation (5.7) of technical Report TR 029, Section 5.2.3.3		[-]		2,0			
Partial safety factor		$\gamma_{Mcp}^{1)}$		[-]			
				1,5 ²⁾			
Concrete edge failure							
Partial safety factor		$\gamma_{Mc}^{1)}$		[-]			
				1,5 ²⁾			

¹⁾ In absence of other national regulations.

²⁾ The partial safety factor $\gamma_2 = 1,0$ is included.

Table 13: Displacements of internal threaded anchors UVT Top I to tension load

Size		M 8	M 10	M 12	M 16	M 20
Non-cracked concrete and cracked concrete; temperature range I to II						
Displacement	δ_{N0} [mm/(N/mm ²)]	0,09	0,10	0,10	0,11	0,13
Displacement	$\delta_{N\infty}$ [mm/(N/mm ²)]	0,13	0,15	0,15	0,17	0,19

Calculation of characteristic displacement with $\delta_N = (\delta_{N0} \cdot \tau_{sd}) / 1,4$

Table 14: Displacements of internal threaded anchors UVT Top I to shear load

Size		M 8	M 10	M 12	M 16	M 20
Displacement	δ_{V0} [mm/kN]	0,12	0,09	0,08	0,07	0,05
Displacement	$\delta_{V\infty}$ [mm/kN]	0,18	0,14	0,12	0,10	0,08

Calculation of characteristic displacement with $\delta_V = (\delta_{V0} \cdot V_{sd}) / 1,4$

BTI compound mortar UVT 390 Top-Z

Internal threaded anchors UVT Top I
Characteristic values to shear load
Displacements

Annex 13

of European
technical approval

ETA-11/0244

Table 15: Characteristic values to tension load reinforcing bars

Size	Ø d	8	10	12	14	16	18	20	22	24	25	26	28	30	32	34	36	40		
Steel failure																				
Characteristic resistance reinforcing bars ⁵⁾	$N_{Rk,s}$ [kN]	28	44	63	85	111	140	173	209	249	270	292	339	389	443	499	560	691		
Partial safety factor	$\gamma_{Ms,N}$ ¹⁾ [-]	1,4																		
Combined pullout and concrete cone failure																				
Diameter for calculation	d [mm]	8	10	12	14	16	18	20	22	24	25	26	28	30	32	34	36	40		
Characteristic bond resistance in non-cracked concrete C20/25																				
Temperature range I ⁴⁾ (60°C / 35°C)	$\tau_{Rk,ucr}$ [N/mm ²]	16	15	15	14	14	14	13	13	13	13	13	13	12	12	12	12	12		
Temperature range II ⁴⁾ (72°C / 50°C)	$\tau_{Rk,ucr}$ [N/mm ²]	13	12	12	12	11	11	11	11	11	10	10	10	10	10	10	9,5	9,5		
Characteristic bond resistance in cracked concrete C20/25																				
Temperature range I ⁴⁾ (60°C / 35°C)	$\tau_{Rk,cr}$ [N/mm ²]	7	7	7	7	7	7	7	7	7	7	7	7	7	5	5	5	5		
Temperature range II ⁴⁾ (72°C / 50°C)	$\tau_{Rk,cr}$ [N/mm ²]	6	6	6	6	6	6	6	6	6	6	6	6	6	4	4	4	4		
Increasing factors for τ_{Rk}	ψ_c C25/30 [-]	1,02																		
	C30/37 [-]	1,04																		
	C35/45 [-]	1,06																		
	C40/50 [-]	1,07																		
	C45/55 [-]	1,08																		
	C50/60 [-]	1,09																		
Splitting failure																				
Edge distance $c_{cr,sp}$ [mm]	$h / h_{ef} \geq 2,0$	1,0 h_{ef}																		
	$2,0 > h / h_{ef} > 1,3$	4,6 h_{ef} - 1,8 h																		
	$h / h_{ef} \leq 1,3$	2,26 h_{ef}																		
Spacing	$s_{cr,sp}$ [mm]	2 $c_{cr,sp}$																		
Partial safety factor	$\gamma_{Mp} = \gamma_{Mc} = \gamma_{Msp}$ ¹⁾ [-]	1,5 ²⁾						1,8 ³⁾												

¹⁾ In absence of other national regulations.

²⁾ The partial safety factor $\gamma_2 = 1,0$ is included

³⁾ The partial safety factor $\gamma_2 = 1,2$ is included

⁴⁾ See annex 2

⁵⁾ The values given in Table 15 are valid for reinforcing bars with $f_{uk} = 550$ N/mm² and $f_{yk} = 500$ N/mm². Other reinforcing bars have to be calculated according to TR 029, Equation (5.1).

BTI compound mortar UVT 390 Top-Z

Reinforcing bars
Characteristic values to tension load

Annex 14

of European
technical approval

ETA-11/0244

Table 16: Characteristic values to shear load reinforcing bars¹⁾

Size	Ø d	8	10	12	14	16	18	20	22	24	25	26	28	30	32	34	36	40
Steel failure without lever arm																		
Charac- teristic resistance	$V_{Rk,s}$ [kN]	13,8	21,6	31,1	42,4	55,3	70	87	105	125	135	146	170	195	221	250	280	346
Partial safety factor	$\gamma_{Ms,V}$ [-]	1,5																
Steel failure with lever arm																		
Charac- teristic resistance	$M_{Rk,s}^0$ [Nm]	33	65	112	178	265	378	518	690	896	1012	1139	1422	1749	2123	2547	3023	4147
Partial safety factor	$\gamma_{Ms,V}$ [-]	1,5																
Concrete pryout failure																		
Factor k in Equation (5.7) of Technical Report TR 029, Section 5.2.3.3	[-]	2,0																
Partial safety factor	$\gamma_{Mcp}^{2)}$ [-]	1,5 ³⁾																
Concrete edge failure																		
Partial safety factor	$\gamma_{Mc}^{2)}$ [-]	See Technical Report TR 029, Section 5.2.3.4																
Partial safety factor	$\gamma_{Mc}^{2)}$ [-]	1,5 ³⁾																

¹⁾ The values given in Table 16 are valid for reinforcing bars with $f_{uk} = 550 \text{ N/mm}^2$ and $f_{yk} = 500 \text{ N/mm}^2$. Other reinforcing bars have to be calculated according to TR 029, Equation (5.1).

²⁾ In absence of other national regulations.

³⁾ The partial safety factor $\gamma_2 = 1,0$ is included.

Table 17: Displacements of reinforcing bars to tension load

Size	Ø	8	10	12	14	16	18	20	22	24	25	26	28	30	32	34	36	40
Non-cracked concrete and cracked concrete; temperature range I to II																		
Displace- ment	$\delta_{No} \left[\frac{\text{mm}}{(\text{N/mm}^2)} \right]$	0,07	0,08	0,09	0,09	0,10	0,10	0,11	0,11	0,12	0,12	0,12	0,13	0,13	0,13	0,14	0,14	0,15
Displace- ment	$\delta_{N\infty} \left[\frac{\text{mm}}{(\text{N/mm}^2)} \right]$	0,11	0,12	0,13	0,14	0,15	0,16	0,16	0,17	0,18	0,18	0,18	0,19	0,19	0,20	0,20	0,21	0,22

Calculation of characteristic displacement with $\delta_N = (\delta_{No} \cdot \tau_{sd})/1,4$

Table 18: Displacements of reinforcing bars to shear load

Size	Ø	8	10	12	14	16	18	20	22	24	25	26	28	30	32	34	36	40
Displace- ment	δ_{V0} [mm/kN]	0,18	0,15	0,12	0,10	0,09	0,08	0,07	0,07	0,06	0,06	0,06	0,05	0,05	0,05	0,05	0,05	0,04
Displace- ment	$\delta_{V\infty}$ [mm/kN]	0,27	0,22	0,18	0,16	0,14	0,12	0,11	0,10	0,09	0,09	0,08	0,08	0,07	0,06	0,06	0,06	0,05

Calculation of characteristic displacement with $\delta_V = (\delta_{V0} \cdot V_{sd})/1,4$

BTI compound mortar UVT 390 Top-Z

Reinforcing bars
Characteristic values to shear load
Displacements

Annex 15

of European
technical approval
ETA-11/0244

Table 19: Characteristic values to tension load BTI rebar anchor FRA

Size		M12	M16	M20	M24
Steel failure					
Characteristic resistance	$N_{Rk,s}$ [kN]	68	126	196	283
Partial safety factor	$\gamma_{Ms,N}^{1)}$ [-]	1,56			
Combined pullout and concrete cone failure					
Diameter for calculation	d [mm]	12	16	20	25
Characteristic bond resistance in non-cracked concrete C20/25					
Temperature range I ⁴⁾ (60°C / 35°C)	$\tau_{Rk,ucr}$ [N/mm ²]	15	14	13	13
Temperature range II ⁴⁾ (72°C / 50°C)	$\tau_{Rk,ucr}$ [N/mm ²]	12	11	11	11
Characteristic bond resistance in cracked concrete C20/25					
Temperature range I ⁴⁾ (60C / 35°C)	$\tau_{Rk,cr}$ [N/mm ²]	7			
Temperature range II ⁴⁾ (72°C / 50°C)	$\tau_{Rk,cr}$ [N/mm ²]	6			
Increasing factors for τ_{Rk}	ψ_c	C25/30 [-]	1,02		
		C30/37 [-]	1,04		
		C35/45 [-]	1,06		
		C40/50 [-]	1,07		
		C45/55 [-]	1,08		
		C50/60 [-]	1,09		
Splitting failure					
Edge distance $c_{cr,sp}$ [mm]	$h / h_{ef} \geq 2,0$	$1,0 h_{ef}$			
	$2,0 > h / h_{ef} > 1,3$	$4,6 h_{ef} - 1,8 h$			
	$h / h_{ef} \leq 1,3$	$2,26 h_{ef}$			
Spacing	$s_{cr,sp}$ [mm]	$2 c_{cr,sp}$			
Partial safety factor	$\gamma_{Mp} = \gamma_{Mc} = \gamma_{Msp}^{1)}$ [-]	1,5 ²⁾	1,8 ³⁾		

¹⁾ In absence of other national regulations.

²⁾ The partial safety factor $\gamma_2 = 1,0$ is included

³⁾ The partial safety factor $\gamma_2 = 1,2$ is included

⁴⁾ See annex 2

BTI compound mortar UVT 390 Top-Z

BTI rebar anchors FRA
Characteristic values to tension load

Annex 16

of European
technical approval

ETA-11/0244

Table 20: Characteristic values to shear load BTI rebar anchor FRA

Size		M12	M16	M20	M24
Steel failure without lever arm					
Characteristic resistance	$V_{Rk,s}$ [kN]	33,7	63	98	141
Partial safety factor	$\gamma_{Ms,V}$ [-]	1,25			
Steel failure with lever arm					
Characteristic bending moment	$M_{Rk,s}^0$ [Nm]	105	266	519	896
Partial safety factor	$\gamma_{Ms,V}$ [-]	1,25			
Concrete pryout failure					
Factor k in Equation (5.7) of Technical Report TR 029, Section 5.2.3.3	k [-]	2,0			
Partial safety factor	$\gamma_{Mcp}^{1)}$ [-]	1,5 ²⁾			
Concrete edge failure					
Partial safety factor	$\gamma_{Mc}^{1)}$ [-]	1,5 ²⁾			

¹⁾ In absence of other national regulations.

²⁾ The partial safety factor $\gamma_2 = 1,0$ is included.

Table 21: Displacements of BTI rebar anchors FRA to tension load

Size	\emptyset	12	16	20	24
Non-cracked and cracked concrete; temperature range I to II					
Displacement	δ_{NO} [mm/(N/mm ²)]	0,09	0,10	0,11	0,12
Displacement	$\delta_{N\infty}$ [mm/(N/mm ²)]	0,13	0,15	0,16	0,18

Calculation of characteristic displacement with $\delta_N = (\delta_{NO} \cdot \delta_{Sd}) / 1,4$

Table 22: Displacements of BTI rebar anchors FRA to shear load

Size	\emptyset	12	16	20	24
Displacement	δ_{V0} [mm/kN]	0,12	0,09	0,07	0,06
Displacement	$\delta_{V\infty}$ [mm/kN]	0,18	0,14	0,11	0,09

Calculation of characteristic displacement with $\delta_V = (\delta_{V0} \cdot V_{Sd}) / 1,4$

BTI compound mortar UVT 390 Top-Z

BTI rebar anchors FRA
 Characteristic values to shear load
 Displacements

Annex 17
 of European
 technical approval
ETA-11/0244