



European Technical Approval ETA-11/0261

English translation prepared by DIBt - Original version in German language

Handelsbezeichnung
Trade name

SCHAEFER KALOTHERM System Leicht EPS und Fein EPS

Zulassungsinhaber
Holder of approval

SCHAEFER KRUSEMARK GmbH & Co. KG
Louise-Seher-Straße 6
65582 Diez
DEUTSCHLAND

Zulassungsgegenstand
und Verwendungszweck
*Generic type and use
of construction product*

Außenseitiges Wärmedämm-Verbundsystem mit Putzschicht zur
Wärmedämmung von Gebäuden
*External Thermal Insulation Composite System with rendering for use
as external thermal insulation of building wall*

Geltungsdauer:
Validity: vom
from
bis
to

4 August 2011
4 August 2016

Herstellwerk
Manufacturing plant

SCHAEFER KRUSEMARK GmbH & Co. KG
Louise-Seher-Straße 6
65582 Diez
DEUTSCHLAND

Diese Zulassung umfasst
This Approval contains

20 Seiten einschließlich 1 Anhang
20 pages including 1 annex

I LEGAL BASES AND GENERAL CONDITIONS

- 1 This European technical approval is issued by Deutsches Institut für Bautechnik in accordance with:
- Council Directive 89/106/EEC of 21 December 1988 on the approximation of laws, regulations and administrative provisions of Member States relating to construction products¹, modified by Council Directive 93/68/EEC² and Regulation (EC) N° 1882/2003 of the European Parliament and of the Council³;
 - Gesetz über das In-Verkehr-Bringen von und den freien Warenverkehr mit Bauprodukten zur Umsetzung der Richtlinie 89/106/EWG des Rates vom 21. Dezember 1988 zur Angleichung der Rechts- und Verwaltungsvorschriften der Mitgliedstaaten über Bauprodukte und anderer Rechtsakte der Europäischen Gemeinschaften (Bauproduktengesetz - BauPG) vom 28. April 1998⁴, as amended by law of 31 October 2006⁵;
 - Common Procedural Rules for Requesting, Preparing and the Granting of European technical approvals set out in the Annex to Commission Decision 94/23/EC⁶;
 - Guideline "External Thermal Insulation Composite Systems with Rendering", ETAG 004, edition March 2000.
- 2 Deutsches Institut für Bautechnik is authorized to check whether the provisions of this European technical approval are met. Checking may take place in the manufacturing plant. Nevertheless, the responsibility for the conformity of the products to the European technical approval and for their fitness for the intended use remains with the holder of the European technical approval.
- 3 This European technical approval is not to be transferred to manufacturers or agents of manufacturers other than those indicated on page 1, or manufacturing plants other than those laid down in the context of this European technical approval.
- 4 This European technical approval may be withdrawn by the Deutsches Institut für Bautechnik, in particular pursuant to information by the Commission according to Article 5(1) of Council Directive 89/106/EEC.
- 5 Reproduction of this European technical approval including transmission by electronic means shall be in full. However, partial reproduction can be made with the written consent of the Deutsches Institut für Bautechnik. In this case partial reproduction has to be designated as such. Texts and drawings of advertising brochures shall not contradict or misuse the European technical approval.
- 6 The European technical approval is issued by the approval body in its official language. This version corresponds fully to the version circulated within EOTA. Translations into other languages have to be designated as such.

¹ Official Journal of the European Communities L 40, 11 February 1989, p. 12
² Official Journal of the European Communities L 220, 30 August 1993, p. 1
³ Official Journal of the European Union L 284, 31 October 2003, p. 25
⁴ *Bundesgesetzblatt Teil I 1998*, p. 812
⁵ *Bundesgesetzblatt Teil I 2006*, p. 2407, 2416
⁶ Official Journal of the European Communities L 17, 20 January 1994, p. 34

II BESONDERE BESTIMMUNGEN DER EUROPÄISCHEN TECHNISCHEN ZULASSUNG

1 Definition of products and intended use

The External Thermal Insulation Composite System "SCHAEFER KALOTHERM System Leicht EPS und Fein EPS" called ETICS in the following text, is designed and installed in accordance with the ETA-holder's design and installation instructions, deposited with the Deutsches Institut für Bautechnik (DIBt). The ETICS comprises the following components, which are factory-produced by the ETA-holder or a supplier. It's made up on site from these. The ETA-holder is ultimately responsible for the ETICS.

1.1 Definition of the construction product

	Components (see clause 2.3 for further description, characteristics and performances)	Coverage [kg/m ²]	Thickness [mm]
Insulation material with associated method of fixing	Bonded ETICS: <ul style="list-style-type: none"> • Insulation product factory-prefabricated expanded polystyrene (EPS) to EN 13163:2008 <ul style="list-style-type: none"> – Standard-EPS – elastified EPS • Adhesives (minimum bonded surface 40 %) <ul style="list-style-type: none"> – UNO FEIN 510 (cement based powder requiring addition of about 30 % of water) – MULTI 550 (cement based powder requiring addition of about 20 % of water) – MULTIPLUS 560 (cement based powder requiring addition of about 20 % of water) – MULTILIGHT PLUS 570 (cement based powder requiring addition of about 20 % of water) – Dispersionskleber * (organic based ready to use paste) 	<ul style="list-style-type: none"> – – 4.5 to 7.0 (prepared) 5.2 to 7.8 (Nassauftrag) 4.2 to 6.3 (prepared) 2.0 – 3.0 (prepared) 	<ul style="list-style-type: none"> ≤ 400* ≤ 200* - - - -
	Mechanically fixed ETICS with profiles and supplementary adhesive: <ul style="list-style-type: none"> • Insulation product factory-prefabricated expanded polystyrene (EPS) to EN 13163:2008 <ul style="list-style-type: none"> – Standard-EPS • Supplementary adhesive (equal to bonded ETICS) • Profiles <ul style="list-style-type: none"> – "Halteleiste PVC" – "Verbindungsleiste PVC" Polyvinylchlorid (PVC) – Profiles	<ul style="list-style-type: none"> – 	<ul style="list-style-type: none"> 60 to 200*

	Components (see clause 2.3 for further description, characteristics and performances)	Coverage [kg/m ²]	Thickness [mm]
Insulation material with associated method of fixing	<ul style="list-style-type: none"> • Anchors for profiles <ul style="list-style-type: none"> – ejothem SK U – WS 8 L – WS 8 N – ejothem SDK U – IsoFux ND-8Z – SDM-T plus, SDF-K plus U, SDF-S plus – ejothem NK U 		
	<p>Mechanically fixed ETICS with anchors and supplementary adhesive:</p> <ul style="list-style-type: none"> • Insulation product factory-prefabricated expanded polystyrene (EPS) to EN 13163:2008 <ul style="list-style-type: none"> – Standard-EPS – elastified EPS • Supplementary adhesive (equal to bonded ETICS) • Anchors for insulation product <ul style="list-style-type: none"> – ejothem ST U – KEW TSD 8 – TERMOZ 8 SV – KOELNER KI8M – ejothem NTK U <p>and anchors with ETA according to ETAG 014⁷ with characteristics defined in clause 2.3.2</p>	<p>–</p> <p>–</p>	<p>60 to 300*</p> <p>60 to 200*</p>
Base coat	<p>UNO FEIN 510 Identical with the equally named adhesive given above</p>	4.5 to 7.5 (prepared)	3.0 to 5.0
	<p>MULTILIGHT PLUS 570 Identical with the equally named adhesive given above</p>	4.2 to 6.3 (prepared)	4.0 to 6.0
Glass fibre mesh	<p>System Armierungsgewebe 4x4 Alkali- and slide-resistant glass fibre mesh with mass per unit area of about ca. 160 g/m² und einer Maschenweite von ca. 4.0 mm x 4.0 mm.</p> <p>System Armierungsgewebe 6x6** Alkali- and slide-resistant glass fibre mesh with mass per unit area of about 200 g/m² and mesh size of about 6.0 mm x 6.0 mm.</p> <p>Only be used with the base coat MULTI LIGHT PLUS 570. and the finishing coat KRATZPUTZ</p>	–	–

	Components (see clause 2.3 for further description, characteristics and performances)	Coverage [kg/m ²]	Thickness [mm]
Key coat	Isoliergrund Quarzgrund Ready to use pigmented acrylic-resin dispersion liquid To be used with all finishing coats indicated hereafter. For the compatibility with the finishing coats see below.	0.10 - 0.20 l/m ² 0.15 - 0.20 l/m ²	– –
Finishing coat	To use with key coat "Isoliergrund" oder "Quarzgrund" if applicable: *** <ul style="list-style-type: none"> Thin layered cement based powder requiring addition of about 27 - 33 % of water: <p>OPTIMAL</p> <ul style="list-style-type: none"> structure Scheibenputz (particle size 1.5 to 4.0 mm) structure Rillenputz (particle size 2.5 to 5.0 mm) structure Strukturputz (particle size 1.5 to 2.5 mm) 	3.0 to 5.0 (prepared)	1.5 to 4.5
	To use with key coat "Quarzgrund" if applicable: *** <ul style="list-style-type: none"> Ready to use pastes –acrylic-resin binder <p>SILIKONHARZPUTZ</p> <ul style="list-style-type: none"> Rillenputz (particle size 2 and 3 mm) Scheibenputz (particle size 1.5 to 3 mm) <p>KUNSTHARZPUTZ</p> <ul style="list-style-type: none"> structure Rillenputz (particle size 2 and 3 mm) structure Scheibenputz (particle size 1.5 to 3 mm) Ready to use pastes – silicate/acrylic-resin binder: <p>SILIKATPUTZ</p> <ul style="list-style-type: none"> structure Rillenputz (particle size 2 and 3 mm) structure Scheibenputz (particle size 1.5 to 3 mm) To use without key coat: <ul style="list-style-type: none"> Thick layered cement based powder requiring addition of about 20 to 27 % of water: <p>KRATZPUTZ**</p> (particle size 2.5 to 5.0 mm) 	3.0 to 4.5 (prepared)	1.5 to 4.5
Ancillary material	Description in accordance with clause 3.2.2.5 of ETAG 004 and decorative coatings compatible with the ETICS to be applied to the finishing coat. Remains the responsibility of the ETA-holder.		
*	The minimum thickness of the insulation product when using the adhesive "Dispersionskleber" is 80 mm		
**	The glass fibre mesh "System Armierungsgewebe 6x6" and the finishing coat "KRATZPUTZ" be used only with the base coat "MULTILIGHT 570".		
***	The instruction to the installer concerning the use of a key coat remains the responsibility of the ETA-holder.		

1.2 Intended use

This ETICS is intended to be used as external insulation to the walls of buildings made of masonry (bricks, blocks, stones ...) or concrete (cast on site or as prefabricated panels) with and without rendering (Class A1 or A2 - s1,d0 according to EN 13501-1:2007). It shall be designed to give the wall to which it is applied satisfactory thermal insulation.

The ETICS is non load-bearing construction element. It does not contribute directly to the stability of the wall on which it is installed, but it can contribute to durability by providing enhanced protection from the effects of weathering.

The ETICS can be used on new or existing (retrofit) vertical walls.

The ETICS is not intended to ensure the air tightness of the building structure.

The choice of the method of fixing depends on the characteristics of the substrate, which could need preparation (see clause 7.2.1 of ETAG 004) and on the national instructions.

The provisions made in this European technical approval (ETA) based upon the assumed intended working life of the ETICS of at least 25 years, provided that the conditions laid down in clauses 4.2, 5.1 and 5.2 for the packaging, transport, storage, installation as well as appropriate use, maintenance and repair are met. The indications given on the working life cannot be interpreted as a guarantee given by the manufacturer or the Approval Body, but should only be regarded as a means to choosing the appropriate products in relation to the expected, economically reasonable working life of the works.

2 Characteristics of products and methods of verification

2.1 General

The assessment of the fitness for use of the ETICS for the intended use according to the Essential Requirements was carried out in compliance with ETAG 004, "Guideline for European Technical Approval of External Thermal Insulation Composite Systems with rendering", edition March 2000 (called ETAG 004 in this ETA).

Characteristics (of the components as well as of the ETICS), not mentioned in this ETA nor in the annex shall correspond to the respective values laid down in the technical documentation of this ETA.

2.2 Characteristics of the ETICS

2.2.1 Reaction to fire

Rendering system: Base coat with finishing coat and compatible key coat indicated hereafter	Maximum declared organic content	Class according to EN 13501-1:2007
OPTIMAL with key coat "Quarzgrund" oder "Isoliergrund"	Base coat ≤ 3.7 % Finishing coat ≤ 0.6 %	B – s1, d0
KRATZPUTZ		
SILIKATPUTZ with key coat "Quarzgrund"	Base coat ≤ 3.7 % Finishing coat ≤ 4.5 %	B – s2, d0
SILIKONHARZPUTZ with key coat "Quarzgrund"	Base coat ≤ 3.7 % Finishing coat ≤ 8.8 %	
KUNSTHARZPUTZ with key coat "Quarzgrund"		

Mounting and fixing

(for all end use applications given in clause 1.2 of the ETA)

The assessment of reaction to fire is based on tests with a maximum insulation layer thickness of 180 mm (testing according to EN 13823:2002 – SBI-test), resp. 60 mm (testing according to EN ISO 11925-2:2002) and a maximum insulation material (EPS) density of 30 kg/m³ as well as rendering systems with three / two different types of binder (cement based, silicate based and organic based / inorganic and organic) each with the highest organic content and the lowest amount of flame retardant and additives.

The manufacturer of the tested EPS is Brohlburg, D-56626 Andernach. EPS with higher density than tested or with other chemical composition or of an other manufacturer, which fulfils the requirements of clause 2.3.1 and is deposited with the DIBt, can be used if it fulfils the requirements of Class E according to EN 13501-1:2007 by testing specimens with a thickness of 10 mm and with the highest possible density.

For rendering systems with cement based finishing coats the assessment of reaction to fire is based on tests with a particles size of 3 mm (lowest thickness).

For rendering systems with silicate and organic based finishing coats the assessment of reaction to fire is based on tests with particle sizes of 3 mm (lowest and highest thickness).

For the SBI-test the ETICS was mounted directly to a calcium silicate substrate (class A2-s1,d0) according to EN 13238:2001 with a thickness of 6 mm.

For testing according to EN ISO 11925-2:2002 no substrate was used.

The installation of the ETICS was carried out by the approval holder following his design and installation instructions using a single mesh all over the test specimen.

The tests specimens were prefabricated and did not include any joints.

For the SBI-test the lateral edges were covered with the rendering system.

For testing according to EN ISO 11925-2:2002 the edges were not covered with the rendering system (cut edges). The tests were performed with surface flaming of the front side and edge flaming turned by 90.

Anchors were not included in the tested ETICS as they have no influence on the test result.

Note:

A European reference fire scenario for facades has not been laid down. In some Member States, the classification of ETICS according to EN 13501-1:2007 might not be sufficient for the use in facades. An additional assessment of ETICS according to national provisions (e.g. on the basis of a large scale test) might be necessary to comply with Member State regulations, until the existing European classification system has been completed.

2.2.2 Water absorption (capillarity test)

Base coat	Water absorption after 1 h < 1 kg/m ²	Water absorption after 24 h < 0.5 kg/m ²
UNO FEIN 510	x	x
MULTILIGHT PLUS 570	x	x

Rendering system: Base coat with finishing coat and compatible key coat indicated hereafter	Water absorption after 24 h	
	< 0.5 kg/m ²	≥ 0.5 kg/m ²
UNO FEIN 510 + Quarzgrund + SILIKATPUTZ R		x
UNO FEIN 510 + Quarzgrund + SILIKONHARZPUTZ R	x	
UNO FEIN 510 + Quarzgrund + KUNSTHARZPUTZ R		x
MULTILIGHT PLUS 570 + Quarzgrund + SILIKATPUTZ R		x
MULTILIGHT PLUS 570 + Quarzgrund + SILIKONHARZPUTZ	x	
MULTILIGHT PLUS 570 + Quarzgrund + KUNSTHARZPUTZ R		x

2.2.3 Hygrothermal behaviour

Hygrothermal cycles have been performed on a rig with the base coat "UNO FEIN 510" and "MULTILIGHT PLUS 570", each carried out on a test wall. None of the following defects occur during the testing:

- blistering or peeling of any finishing
- failure or cracking associated with joints between insulation product boards or profiles fitted with the system
- detachment of render
- cracking allowing water penetration to the insulation layer

The ETICS with the base coats "UNO FEIN 510" und "MULTILIGHT PLUS 570" is so assessed resistant to hygrothermal cycles.

2.2.4 Freeze/thaw behaviour

The water absorption of the both base coats "UNO FEIN 510" and "MULTILIGHT PLUS 570" as well as their rendering systems with finishing coat "SILIKONHARZPUTZ" is less than 0.5 kg/m² after 24 hours. The corresponding configurations of the ETICS are so assessed as freeze/thaw resistant.

The ETICS with finishing coats "SILIKATPUTZ" and "KUNSTHARZPUTZ" have been assessed as freeze/thaw resistant according to the simulated method.

2.2.5 Impact resistance

The verified resistance to hard body impact and to perforation of the ETICS with different mesh configurations results in the classification into categories listed below.

Rendering system: Base coat with finishing coat indicated hereafter	Single standard mesh
UNO FEIN 510	Category II
UNO FEIN 510 with OPTIMAL R	Category II
UNO FEIN 510 with SILIKATPUTZ R	Category II
UNO FEIN 510 with KUNSTHARZPUTZ R	Category II
UNO FEIN 510 with SILIKONHARZPUTZ R	Category I
MULTILIGHT PLUS 570	Category II

Rendering system: Base coat with finishing coat indicated hereafter	Single standard mesh
MULTILIGHT PLUS 570 with OPTIMAL R	Category II
MULTILIGHT PLUS 570 with KRATZPUTZ	Category II
MULTILIGHT PLUS 570 with SILIKATPUTZ R	Category II
MULTILIGHT PLUS 570 with KUNSTHARZPUTZ R	Category II
MULTILIGHT PLUS 570 with SILIKONHARZPUTZ R	Category II

2.2.6 Water vapour permeability

Rendering system: Base coat with finishing coat and compatible key coat indicated hereafter (evaluated without decorative coating or key coat)	Equivalent air thickness s_d
UNO FEIN 510	≤ 1.0 m (Test result obtained with a layer thickness 4 mm: 0.03 m)
UNO FEIN 510 + Quarzgrund + OPTIMAL R	≤ 1.0 m (Test result obtained with a layer thickness 7 mm: 0.12 m)
UNO FEIN 510 + Quarzgrund + SILIKATPUTZ R	≤ 1.0 m (Test result obtained with a layer thickness 7mm: 0.13 m)
UNO FEIN 510 + Quarzgrund + SILIKONHARZPUTZ R	≤ 1.0 m (Test result obtained with a layer thickness 7 mm: 0.25 m)
UNO FEIN 510 + Quarzgrund + KUNSTHARZPUTZ R	≤ 1.0 m (Test result obtained with a layer thickness 7 mm: 0.18 m)
MULTILIGHT PLUS 570	≤ 1.0 m (Test result obtained with a layer thickness 5 mm: 0.05 m)
MULTILIGHT PLUS 570 + Quarzgrund + OPTIMAL R	≤ 1.0 m (Test result obtained with a layer thickness 8 mm: 0.15 m)
MULTILIGHT PLUS 570 + Quarzgrund + KRATZPUTZ R	≤ 1.0 m (Test result obtained with a layer thickness 13 mm: 0.24 m)
MULTILIGHT PLUS 570 + Quarzgrund + SILIKATPUTZ R	≤ 1.0 m (Test result obtained with a layer thickness 8 mm: 0.16 m)
MULTILIGHT PLUS 570 + Quarzgrund + SILIKONHARZPUTZ R	≤ 1.0 m (Test result obtained with a layer thickness 8 mm: 0.30 m)
MULTILIGHT PLUS 570 + Quarzgrund + KUNSTHARZPUTZ R	≤ 1.0 m (Test result obtained with a layer thickness 8 mm: 0.19 m)

2.2.7 Emission of dangerous substances or radiation

The ETICS complies with the provisions of Guidance Paper H ("A harmonized approach related to dangerous substances under the construction product directives Revision August 2002").

In addition to the specific clauses relating to dangerous substances contained in this ETA, there may be other requirements applicable to the products falling within its scope (e.g. transposed European legislation and national laws, regulations and administrative provisions). In order to meet the provisions of the Construction Products Directive, these requirements need also to be complied with, when and where they apply.

2.2.8 Safety in use

2.2.8.1 Bond strengths

Bond strength between base coat and insulation product (EPS)

Base coat	Conditioning		
	Initial state	After hygrothermal cycles	After freeze/thaw test
UNO FEIN 510	≥ 0.08 MPa	≥ 0.08 MPa	Test not required because freeze/thaw cycles not necessary
MULTILIGHT PLUS 570	≥ 0.08 MPa	≥ 0.08 MPa	

Bond strength between adhesive and substrate resp. insulation product (EPS)

Adhesive	Substrate resp. insulation product	Conditioning		
		Initial state	2 d immersion in water + 2 h drying	2 d immersion in water + 7 d drying
UNO FEIN 510	Concrete	≥ 0.25 MPa	≥ 0.08 MPa	≥ 0.25 MPa
	EPS	≥ 0.08 MPa	≥ 0.03 MPa	≥ 0.08 MPa
MULTIPLUS 570, MULTILIGHT PLUS 570	Concrete	≥ 0.25 MPa	≥ 0.08 MPa	≥ 0.25 MPa
	EPS	≥ 0.08 MPa	≥ 0.03 MPa	≥ 0.08 MPa
Dispersionskleber	Concrete	≥ 0.25 MPa	≥ 0.08 MPa	≥ 0.25 MPa
	Brick	≥ 0.25 MPa	≥ 0.08 MPa	≥ 0.25 MPa
	EPS	≥ 0.08 MPa	≥ 0.03 MPa	≥ 0.08 MPa

Bonded surface:

For bonded ETICS the calculated minimal bonded surface area, according to ETAG 004, clause 6.1.4.1.3 is 40 %

2.2.8.2 Fixing strength (displacement test)

Test not required because the ETICS fulfils the following criteria to clause 5.1.4.2 of ETAG 004:

- the bonded area exceeds 20 %
- $E \cdot d < 50\,000 \text{ N/mm}$
(E: modulus of elasticity of the base coat – d: mean dried thickness of the base coat)

2.2.8.3 Wind load resistance

Safety in use of mechanically fixed ETICS using profiles

The following failure loads only apply to the listed combination (EPS panel's characteristics) / (way of fixing the profiles) and the characteristics of the insulation product given in clause 2.3.1.

Characteristics of the EPS (Standard-EPS)	Dimensions	500 mm x 500 mm
	Thickness	≥ 60 mm
	Tensile strength perpendicular to the faces	≥ 150 kPa
	Shear modulus	≥ 1.0 N/mm ²
Versagenslasten [N / Platte] (Statischer Schaumblockversuch)	Horizontal profiles fixed every 30 cm and 49.4 cm long vertical connection profiles	Minimal: 950 Average: 1010

Safety in use of mechanically fixed ETICS using anchors

The following failure loads only apply to the listed combination (EPS panel's characteristics) / (anchor plate's characteristics) and the characteristics of the insulation product given in clause 2.3.1.

Apply to all anchors listed in the Table in clause 1.1 mounted on the insulation panels surface				
Characteristics of the EPS (Standard-EPS)	Thickness		≥ 60 mm	
	Tensile strength perpendicular to the faces		≥ 100 kPa	
	Shear modulus		≥ 1.0 N/mm ²	
Plate diameter of anchor			∅ 60 mm	∅ 90 mm
Failure loads [N]	Anchors not placed at the panel joints (Static Foam Block Test)	R _{panel}	Minimal: 510 Average: 520	Minimal: 720 Average: 730
	Anchors placed at the panel joints (Pull-through test)	R _{joint}	Minimal: 400 Average: 430	Minimal: 430 Average: 470

Apply to all anchors listed in the Table in clause 1.1 mounted on the insulation panels surface				
Characteristics of the EPS (elastified EPS)	Thickness		≥ 60 mm	
	Tensile strength perpendicular to the faces		≥ 80 kPa	
	Shear modulus		≥ 0.3 N/mm ²	
Plate diameter of anchor			∅ 60 mm	
Failure loads [N]	Anchors not placed at the panel joints (Static Foam Block Test)	R _{panel}	Minimal: 350 Average: 360	
	Anchors placed at the panel joints (Pull-through test)	R _{joint}	Minimal: 300 Average: 310	

The failure loads specified above only apply to the following anchors with deep mounting under the given conditions of installation:

Anchor	Thickness of the EPS [d]	Conditions of installation *
ejotherm STR U (ETA-04/0023)	100 mm > d ≥ 80 mm (for standard and elastified EPS)	– Maximum installation depth of the anchor plate: 15 mm (≅ thickness of insulation cover) – Maximum depth of die: 5 mm
	≥ 100 mm (for standard and elastified EPS)	– Maximum installation depth of the anchor plate: 15 mm (≅ thickness of insulation cover) – Maximum depth of die: 20 mm
IsoFux NDT8LZ (ETA-05/0080)	≥ 80 mm (for standard and elastified EPS)	– Maximum depth of countersink: 20 mm
TERMOZ 8 SV (ETA-06/0180)	≥ 80 mm (for standard EPS only)	– Maximum installation depth of the anchor plate: 15 mm (≅ thickness of insulation cover)

* According to the appropriate ETA of anchor

The wind load resistance R_d of the ETICS is calculated as follows:

$$R_d = \frac{R_{\text{panel}} \cdot n_{\text{panel}} + R_{\text{joint}} \cdot n_{\text{joint}}}{\gamma}$$

n_{panel} : number (per m²) of anchors not placed at the panel joints

n_{joint} : number (per m²) of anchors placed at the panel joint

γ : national safety factor

2.2.9 Thermal resistance

The nominal value of the additional thermal resistance R provided by the ETICS to the substrate wall is calculated in accordance with EN ISO 6946:2007 from the nominal value of the insulation product's thermal resistance R_D given accompanied to the CE marking and from the thermal resistance of the rendering system R_{render} which is about 0.02 (m² · K)/W.

$$R = R_D + R_{\text{render}}$$

The thermal bridges caused by anchors increase the thermal transmittance U . This influence had to take into account according to EN ISO 6946:2007.

$$U_c = U + \chi_p \cdot n$$

Corrected thermal transmittance

where: $\chi_p \cdot n$ influence of thermal bridges

n number of anchors per m²

χ_p local influence of thermal bridge caused by an anchor. The values listed below can be taken into account, if not specified in the anchor's technical approval

$\chi_p = 0.004$ W/K for anchors with a galvanized steel screw with the head covered by a plastic material

$\chi_p = 0.002$ W/K for anchors with a stainless steel screw with the head covered by plastic material, and for anchors with an air gap at the head of the screw

The thermal bridges caused by profiles are negligible.

2.2.10 Aspects of durability and serviceability

Bond strength after ageing:

Rendering system: Base coat with finishing coat and compatible key coat indicated hereafter	OPTIMAL + Quarzgrund oder Isoliergrund	≥ 0.08 MPa
	KRATZPUTZ	
	SILIKATPUTZ + Quarzgrund	
	SILIKONHARZPUTZ + Quarzgrund	
	KUNSTHARZPUTZ + Quarzgrund	

2.3 Characteristics of the components

Detailed information on the chemical composition and other identifying characteristics of the components, following Annex C of ETAG 004 have been deposited with the DIBt.

Further information can be observed from the product data sheets, which are part of the technical documentation for this ETA.

2.3.1 Thermal insulation product

Factory-prefabricated, uncoated panels made of expanded polystyrene (EPS) to EN 13163:2008 shall be used, having the description and characteristics defined in the Table below.

Description and characteristics	For bonded ETICS	For mechanically fixed ETICS	
		with anchors and supplementary adhesive	with profiles and supplementary adhesive
Reaction to fire; EN 13501-1:2007	Class E *		
Thermal resistance [(m ² ·K)/W]	Defined in the CE marking in reference to EN 13163:2008		
Tolerances			
Length; EN 822:1994	± 0.6 % or ± 3 mm whichever gives the greatest numerical tolerance (class L1 or class L2)		
Width [mm]; EN 822:1994	± 2 (class W2)		
Thickness [mm]; EN 823:1994	± 1 (class T2)		
Squareness [mm/m]; EN 824:1994	± 2 (class S2)		
Flatness [mm/m]; EN 825:1994	5 (class P4)		
Dimensional stability under			
- laboratory conditions [%]; EN 1603:1996	± 0.2 (class DS(N)2)		
- specified temperature and humidity conditions [%]; EN 1604:1996	2 (level DS(70,-)2 or level DS(70,-)1)		
Water absorption (long term partial immersion) [kg/m ²]; EN 12087:1997	W _{ip} ≤ 0.5		
Water vapour diffusion resistance factor; EN 12086:1997	μ = 20 – 78		
Tensile strength perpendicular to the faces in dry conditions ** [kPa]; EN 1607:1996			
- standard EPS	σ _{mt} ≥ 80	σ _{mt} ≥ 100	σ _{mt} ≥ 150
- elastified EPS ***	σ _{mt} ≥ 80	σ _{mt} ≥ 80	Not used
Bending strength ** [kPa]; EN 12089:1997	σ _b ≥ 50		
Apparent density [kg/m ³]; EN 1602:1996	ρ _a ≤ 30		
Shear strength ** [kPa]; EN 12090:1997	20 ≤ f _{tk} ≤ 170		

Description and characteristics	For bonded ETICS	For mechanically fixed ETICS	
		with anchors and supplementary adhesive	with profiles and supplementary adhesive
Shear modulus [MPa]; EN 12090:1997 - standard EPS		$1.0 \leq G_m \leq 3.8$	
- elastified EPS ***	$0.3 \leq G_m \leq 1.0$	$0.3 \leq G_m \leq 1.0$	Not used
Testing of characteristics see EN 13163:2008.			
<p>* See the conditions of clause 2.2.1 for the EPS.</p> <p>** Minimal value of all single values</p> <p>*** Elastified EPS is made from standard EPS by short time high load pressing to reduce the dynamic stiffness. The protection against noise of the entire wall is improved by the use of elastified EPS related to an ETICS with standard EPS.</p>			

Thermal insulation materials for mechanically fixed ETICS with profiles must circumferentially at the edges, 24 mm from the inner surface, get an approx. 3 mm wide and 13 to 18 mm deep groove cut-in at the factory.

2.3.2 Anchors

The anchors listed in the Table in clause 1.1 with reference to the respective ETA are to be used in the mechanically fixed ETICS. The characteristic tension resistance of the anchor shall be taken from the corresponding ETA.

Trade name	ETA-number
ejotherm ST U, ejotherm SK U	ETA-02/0018
WS 8 L	ETA-02/0019
WS 8 N	ETA-03/0019
ejotherm SDK U	ETA-04/0023
KEW TSD 8	ETA-04/0030
IsoFux ND-8Z	ETA-04/0032
SDM-T plus, SDF-K plus U, SDF-K plus	ETA-04/0064
ejotherm NK U	ETA-05/0009
TERMOZ 8 SV	ETA-06/0180
KOELNER KI8M	ETA-06/0191
ejotherm NTK U	ETA-07/0026

Additionally all anchors with ETA according to ETAG 014⁷ with characteristics having the description below shall be used:

- plate diameter of anchor ≥ 60 mm resp. ≥ 90 mm
- plate stiffness ≥ 0.3 kN/mm
- load resistance of the anchor plate ≥ 1.0 kN

These characteristics and the characteristic tension resistance of the anchors shall be taken from the corresponding ETA.

2.3.3 Profiles

Polyvinyl chloride (PVC) profiles, PVC-U, EGL, 082-05-T33 to EN ISO 1163-1:1999, with the measurements according to Annex 1 are to be used in the mechanically fixed ETICS with profiles.

The Pull-through resistance of fixings from profiles is ≥ 500 N.

2.3.4 Render (base coat)

No performance determined for the width of cracks.

2.3.5 Reinforcement (glass fibre mesh)

Characteristics (alkali resistance): Pass

	System-Armierungsgewebe 4x4	
	Warp	Weft
Residual strength after ageing [N/mm]	≥ 20	≥ 20
Relative residual resistance after ageing in % of the strength in the as-delivered state	≥ 50	≥ 50

3 Evaluation and attestation of conformity and CE-marking

3.1 System of attestation of conformity

According to the decision 97/556/EC of the European Commission⁸ amended by 2001/596/EC⁹ system 1 or 2+ of the attestation of conformity applies depending on reaction to fire.

Considering Class B for reaction to fire of the ETICS, the systems of attestation of conformity are system 1 regarding reaction to fire characteristic and system 2+ regarding other characteristics than reaction to fire.

This system of attestation of conformity is defined as follows:

System 1: Certification of the conformity of the product by a notified certification body on the basis of:

- (a) Tasks for the manufacturer:
 - (1) factory production control;
 - (2) further testing of samples taken at the factory by the manufacturer in accordance with a prescribed test plan;
- (b) Tasks for the notified body:
 - (3) initial type-testing of the product;
 - (4) initial inspection of factory and of factory production control;
 - (5) continuous surveillance, assessment and approval of factory production control.

System 2+: Declaration of conformity of the product by the manufacturer on the basis of:

- (a) Tasks for the manufacturer:
 - (1) initial type-testing of the product;
 - (2) factory production control;
 - (3) testing of samples taken at the factory in accordance with a prescribed test plan.

⁸ Official Journal of the European Communities/Union L229/14 of 20.08.1997

⁹ Official Journal of the European Communities/Union L 209/33 of 02.08.2001

- (b) Tasks for the notified body:
- (4) certification of factory production control on the basis of:
- initial inspection of factory and of factory production control;
 - continuous surveillance, assessment and approval of factory production control.

3.2 Responsibilities

3.2.1 Tasks for the manufacturer

3.2.1.1 Factory production control

The manufacturer shall exercise permanent internal control of production. All the elements, requirements and provisions adopted by the manufacturer shall be documented in a systematic manner in the form of written policies and procedures, including records of results performed. This production control system shall insure that the ETICS and the components are in conformity with this ETA.

The manufacturer shall only use raw materials stated in the technical documentation of this ETA. The incoming raw materials are subjected to verifications by the manufacturer before acceptance.

The factory production control shall be in accordance with the "Control plan"¹⁰ which is part of the technical documentation of this ETA. The "Control plan"¹⁰ has been agreed between the manufacturer and the DIBt and is laid down in the context of the factory production control system operated by the manufacturer and deposited with the DIBt.

The results of factory production control shall be recorded and evaluated in accordance with the provisions of the "Control plan"¹⁰. The records include at least the following information:

- designation of the product, the basic materials and components;
- type of control or testing;
- date of manufacture of the product and date of testing of the product or basic materials or components;
- result of control and testing and, if appropriate, comparison with requirements;
- signature of person responsible for factory production control.

The records shall be presented to the notified body involved in continuous surveillance. On request they shall be presented to the DIBt.

3.2.1.2 Other tasks for the manufacturer

For initial type-testing of the ETICS and the components regarding other characteristics than reaction to fire the results of the tests performed as part of the assessment for the ETA shall be used unless there are changes in the production line or plant. In such cases the necessary initial type-testing has to be agreed with the DIBt.

The manufacturer shall, on the basis of a contract, involve a body which is notified for the tasks referred to in clause 3.1 in the field of ETICS in order to undertake the actions laid down in clause 3.2.2. For this purpose, the "Control plan"¹⁰ referred to in clauses 3.2.1.1 and 3.2.2 shall be handed over by the manufacturer to the notified bodies involved.

The manufacturer shall make a declaration of conformity, stating that the ETICS is in conformity with the provisions of ETA-11/0261 issued on 4 August 2011.

¹⁰ The "Control plan" is a confidential part of the European technical approval and only handed over to the notified body involved in the procedure of attestation of conformity. See section 3.2.2.

3.2.2 Tasks for the notified bodies

The notified body shall perform the

- initial inspection of factory and of factory production control,
 - continuous surveillance, assessment and approval of factory production control,
- in accordance with the provisions laid down in the "Control plan"¹⁰.

The notified body shall retain the essential points of its actions referred to above and state the results obtained and conclusions drawn in a written report.

The notified certification body involved by the manufacturer shall issue an EC certificate of conformity of the ETICS which includes the certification of factory production control stating the conformity with the provisions of this ETA.

The notified certification body involved by the manufacturer shall issue an EC certificate of conformity of the factory production control stating the conformity with the provisions of this ETA.

In cases where the provisions of the ETA and its "Control plan"¹⁰ are no longer fulfilled the notified certification body shall withdraw the certificate of conformity and inform the DIBt without delay.

3.3 Marking

3.3.1 CE marking

The CE marking shall be affixed on the accompanying commercial document. The letters "CE" shall be followed by the identification number of the notified certification body and be accompanied by the following additional information:

- the name and address of the ETA-holder (legal entity responsible for the manufacture),
- the last two digits of the year in which the CE marking was affixed,
- the number of the EC certificate of conformity for the ETICS,
- the number of the ETA,
- the number of the ETAG,
- the ETICS trade name.

3.3.2 Additional marking

The respective trade name of the individual components of the ETICS shall be given on the packaging.

In addition to the trade name the following information shall be given in the accompanying commercial document and/or on the packaging of the thermal insulation product:

- minimum value of the tensile strength perpendicular to the faces of the insulation product,
- shear modulus of the insulation product.

4 Assumptions under which the fitness of the product for the intended use was favourably assessed

4.1 Manufacturing

The composition and manufacturing process used for the components of the ETICS shall comply with those on which the approval tests were based. Composition and manufacturing process are deposited at the DIBt.

The ETA is issued for the ETICS on the basis of agreed data/information, deposited with the DIBt, which identifies the ETICS that has been assessed and judged. Changes to the ETICS or the components or their production process, which could result in this deposited data/information being incorrect, should be notified to the DIBt before the changes are introduced. DIBt will decide whether or not such changes affect the approval and consequently the validity of the CE marking on the basis of the approval and if so whether further assessment or alterations to the approval shall be necessary.

4.2 Installation, design and execution

4.2.1 General

The wall on which the ETICS is applied shall be sufficiently stable and airtight. Its stiffness shall be large enough to ensure that the ETICS is not subjected to deformations, which could lead to damage.

The requirements given in ETAG 004, chapter 7, have to be considered.

4.2.2 Installation

The ETICS is installed on site. The approval holder is obliged to instruct all those entrusted with the design and execution of the ETICS about the specific conditions of this ETA and all other details necessary for perfect execution.

Only the components whose trade name is given in clause 1.1 and which have the characteristics according to clause 2.3 may be used for the ETICS.

4.2.3 Design

4.2.3.1 Requirements for the substrate

As to the requirements for the substrate and its preparation, ETAG 004, clause 7.2.1 applies.

The substrate for mechanically fixed systems should have a sufficient resistance for the use of anchors according to clause 2.3.2. The conditions of the ETA for the anchor concerned apply.

4.2.3.2 Resistance to wind load

Judging of sufficient resistance to wind load should be on the basis of the resistance of the fixings according to clause 2.2.8.3 and of the characteristic tension resistance of the used anchor according to clause 2.3.2. Taking into account the national safety factors the design values of resistance are determined. The smaller one of the design resistances of the ETICS (R_d) and of the anchor (N_{Rd}) is decisive.

The determined design wind load suction S_d (taking into account the national safety factors) is compared with the design resistance.

4.2.4 Execution

The manufacturer's design and installation instructions, which are part of the technical documentation for this ETA, shall be observed with respect to the installation of the ETICS and drying times of rendering products.

5 Indications to the manufacturer

5.1 Packaging, transport and storage

Packaging of the components has to be such that they are protected against moisture during transport and storage, unless other measures are foreseen by the manufacturer for this purpose.

The components are to be protected against damage.

European technical approval
ETA-11/0261
English translation prepared by DIBt

Page 19 of 20 | 4 August 2011

5.2 Use, maintenance, repair

To the indications on use, maintenance and repair ETAG 004, clause 7.3 applies.

Uwe Bender
Head of Department

beglaubigt:
Praktiknjo

Horizontal Profil – "PVC Halteleiste" (dimensions in millimetres)

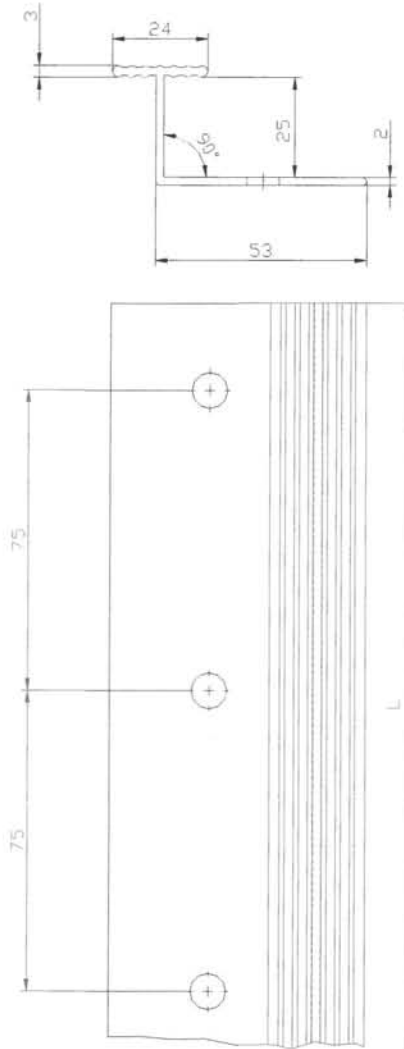

Vertical connection profil "PVC Verbindungsleiste" (dimensions in millimetres)

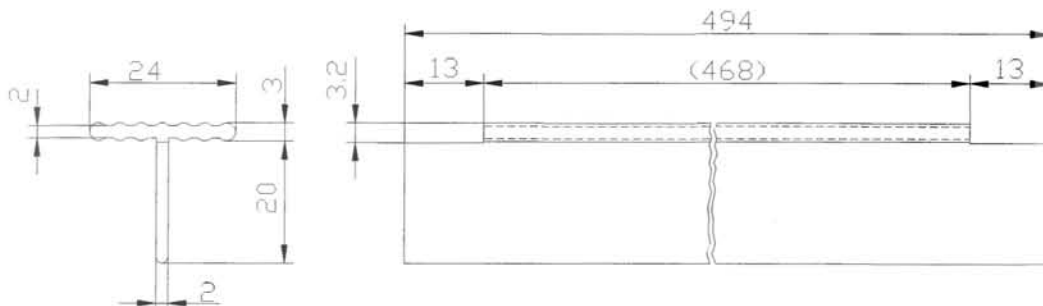

SCHAEFER KALOTHERM System Leicht EPS und Fein EPS

Horizontal and vertical PVC Profiles

Annex 1