

## European Technical Approval ETA-11/0273

English translation prepared by DIBt - Original version in German language

Handelsbezeichnung <i>Trade name</i>	Bewehrungsanschluss mit BTI Injektionsmörtel UVT 390 Top-Z <i>Rebar connection with BTI injection mortar UVT 390 Top-Z</i>
Zulassungsinhaber <i>Holder of approval</i>	BTI Befestigungstechnik GmbH & Co. KG Salzstraße 51 74653 Ingelfingen DEUTSCHLAND
Zulassungsgegenstand und Verwendungszweck <i>Generic type and use of construction product</i>	Nachträglich eingemörtelter Bewehrungsanschluss mit BTI Injektionsmörtel UVT 390 Top-Z <i>Post-installed rebar connection with BTI injection mortar UVT 390 Top-Z</i>
Geltungsdauer: <i>Validity:</i>	vom <i>from</i> bis <i>to</i> 8 July 2011 20 May 2014
Herstellwerke <i>Manufacturing plants</i>	BTI Herstellwerk 1 BTI manufacturing plant 1

Diese Zulassung umfasst  
*This Approval contains*

20 Seiten einschließlich 10 Anhänge  
*20 pages including 10 annexes*

## I LEGAL BASES AND GENERAL CONDITIONS

- 1 This European technical approval is issued by Deutsches Institut für Bautechnik in accordance with:  
  
Council Directive 89/106/EEC of 21 December 1988 on the approximation of laws, regulations and administrative provisions of Member States relating to construction products<sup>1</sup>, modified by Council Directive 93/68/EEC<sup>2</sup> and Regulation (EC) N° 1882/2003 of the European Parliament and of the Council<sup>3</sup>;  
  
Gesetz über das In-Verkehr-Bringen von und den freien Warenverkehr mit Bauprodukten zur Umsetzung der Richtlinie 89/106/EWG des Rates vom 21. Dezember 1988 zur Angleichung der Rechts- und Verwaltungsvorschriften der Mitgliedstaaten über Bauprodukte und anderer Rechtsakte der Europäischen Gemeinschaften (Bauproduktengesetz - BauPG) vom 28. April 1998<sup>4</sup>, as amended by law of 31 October 2006<sup>5</sup>;  
  
Common Procedural Rules for Requesting, Preparing and the Granting of European technical approvals set out in the Annex to Commission Decision 94/23/EC<sup>6</sup>;  
  
Guideline for European technical approval of "Metal anchors for use in concrete - Part 5: Bonded anchors", ETAG 001-05.
- 2 Deutsches Institut für Bautechnik is authorized to check whether the provisions of this European technical approval are met. Checking may take place in the manufacturing plant. Nevertheless, the responsibility for the conformity of the products to the European technical approval and for their fitness for the intended use remains with the holder of the European technical approval.
- 3 This European technical approval is not to be transferred to manufacturers or agents of manufacturers other than those indicated on page 1, or manufacturing plants other than those indicated on page 1 of this European technical approval.
- 4 This European technical approval may be withdrawn by Deutsches Institut für Bautechnik, in particular pursuant to information by the Commission according to Article 5(1) of Council Directive 89/106/EEC.
- 5 Reproduction of this European technical approval including transmission by electronic means shall be in full. However, partial reproduction can be made with the written consent of Deutsches Institut für Bautechnik. In this case partial reproduction has to be designated as such. Texts and drawings of advertising brochures shall not contradict or misuse the European technical approval.
- 6 The European technical approval is issued by the approval body in its official language. This version corresponds fully to the version circulated within EOTA. Translations into other languages have to be designated as such.

<sup>1</sup> Official Journal of the European Communities L 40, 11 February 1989, p. 12  
<sup>2</sup> Official Journal of the European Communities L 220, 30 August 1993, p. 1  
<sup>3</sup> Official Journal of the European Union L 284, 31 October 2003, p. 25  
<sup>4</sup> *Bundesgesetzblatt Teil I* 1998, p. 812  
<sup>5</sup> *Bundesgesetzblatt Teil I* 2006, p. 2407, 2416  
<sup>6</sup> Official Journal of the European Communities L 17, 20 January 1994, p. 34

## II SPECIFIC CONDITIONS OF THE EUROPEAN TECHNICAL APPROVAL

### 1 Definition of the construction products and intended use

#### 1.1 Definition of the product

The subject of this approval is the post-installed connection, by anchoring or overlap connection joint, of reinforcing bars (rebars) in existing structures made of normal weight concrete, using the injection mortar UVT 390 Top-Z in accordance with the regulations for reinforced concrete construction.

Reinforcing bars made of steel with a diameter  $d_s$  from 8 to 40 mm according to Annex 6 or the rebar anchor FRA sizes 12, 16 and 20 according to Annex 7 and injection mortar UVT Top-Z are used for rebar connections. The steel element is placed into a drilled hole filled with injection mortar and is anchored via the bond between embedded element, injection mortar and concrete.

#### 1.2 Intended use

The rebar connection may be used in normal weight concrete of a minimum grade of C12/15 and maximum grade C50/60 according to EN 206-1:2000. It may be used in non-carbonated concrete with the allowable chloride content in concrete of 0.40% (CL 0.40) related to the cement content according to EN 206-1.

Rebar connections with reinforcing bars and rebar anchor FRA may be used for predominantly static loads.

The fire resistance of post-installed rebar connections is not covered by this European technical approval. Fatigue, dynamic or seismic loading of post-installed rebar connections are not covered by this European technical approval.

Rebar connections may only be carried out in a manner, which is also possible with cast-in straight reinforcing bars, e.g. those in the following applications (see Annexes 2 and 3):

- an overlap joint with existing reinforcement in a building component (Figures 1 and 2),
- anchoring of the reinforcement at a slab or beam support, (e.g. according to Figure 3: end support of a slab, designed simply supported, as well as an appropriate general reinforcement for restraint forces),
- anchoring of reinforcement of building components stressed primarily in compression (Figure 4),
- anchoring of reinforcement to cover the envelope line of tensile force in the bending member (Figure 5).

The post-installed rebar connections may be used in the temperature range of  $-40\text{ °C}$  to  $+80\text{ °C}$  (max short term temperature  $+80\text{ °C}$  and max long term temperature  $+50\text{ °C}$ ).

This European technical approval covers anchoring in bore holes made with hammer drilling, compressed air drilling or diamond drilling. The post-installed rebar connection may be installed in dry or wet concrete. It must not be installed in flooded holes.

The rebar may be installed downwards or in a horizontal position. Rebar sizes  $\leq 25\text{ mm}$  and rebar anchor FRA may also be installed in upwards position.

Rebar connections with the rebar anchor FRA may be used for the transmission of tensile forces in the direction of the bar axis only. The transmission of shear forces has to be ensured by appropriate measures. Examples for the application are given in Annex 4, Figure 6 to Figure 8.

- The rebar anchor FRA made of stainless steel may be used in structures subject to dry internal conditions and also in structures subject to external atmospheric exposure (including industrial and marine environment), or exposure to permanently damp internal conditions, if no particular aggressive conditions exist. Such particular aggressive conditions are e.g. permanent, alternating immersion in seawater or the splash zone of seawater, chloride atmosphere of indoor swimming pools or atmosphere with extreme chemical pollution (e.g. in desulphurization plants or road tunnels where de-icing materials are used).
- The rebar anchor FRA C made of high corrosion resistant steel may be used in structures subject to dry internal conditions and also in structures subject to external atmospheric exposure, in permanently damp internal conditions or in other particular aggressive conditions. Such particular aggressive conditions are e.g. permanent, alternating immersion in seawater or the splash zone of seawater, chloride atmosphere of indoor swimming pools or atmosphere with chemical pollution (e.g. in desulphurization plants or road tunnels where de-icing materials are used).

The provisions made in this European technical approval are based on an assumed working life of the post-installed rebar connection of 50 years. The indications given on the working life cannot be interpreted as a guarantee given by the producer, but are to be regarded only as a means for choosing the right products in relation to the expected economically reasonable working life of the works.

## 2 Characteristics of the product and methods of verification

### 2.1 Characteristics of the product

The post-installed rebar connection corresponds to the drawings and provisions given in Annexes 1 to 7. The characteristic material values, dimensions and tolerances not indicated in Annexes 1 to 7 shall correspond to the respective values laid down in the technical documentation<sup>7</sup> of this European technical approval.

The two components of the injection mortar are delivered in unmixed condition in cartridges of sizes 390 ml, 585 ml or 1100 ml according to Annex 1. Each cartridge is marked with the identifying mark "UVT 390 Top-Z" with the processing notes, shelf-life, hazard code, curing time (depending on temperature).

The rebar shall comply with the specifications given in Annex 6. The rebar anchor FRA shall comply with the specifications given in Annex 7. Each rebar anchor with connecting thread made of stainless steel is marked with works symbol and the letters "FRA" according to Annex 7. Each rebar anchor with connecting thread made of high corrosion resistant steel is marked with works symbol and the letters "FRA C" according to Annex 7.

### 2.2 Methods of verification

The assessment of fitness of the post-installed rebar connection for the intended use in relation to the requirements for mechanical resistance and stability and safety in use in the sense of the Essential Requirements 1 and 4 has been made in accordance with the "Guideline for European technical approval of Metal Anchors for Use in Concrete", Part 1 "Anchors in general" and Part 5 "Bonded anchors" and EOTA Technical Report TR 023 "Assessment of post-installed rebar connections"<sup>8</sup>.

<sup>7</sup> The technical documentation of this European technical approval is deposited at the Deutsches Institut für Bautechnik and, as far as relevant for the tasks of the approved bodies involved in the attestation of conformity procedure, is handed over to the approved bodies.

<sup>8</sup> The Technical Report TR 023 "Assessment of post-installed rebar connections" is published on EOTA website [www.EOTA.eu](http://www.EOTA.eu).

In addition to the specific clauses relating to dangerous substances contained in this European technical approval, there may be other requirements applicable to the products falling within its scope (e.g. transposed European legislation and national laws, regulations and administrative provisions). In order to meet the provisions of the Construction Products Directive, these requirements need also to be complied with, when and where they apply.

### 3 Evaluation and attestation of conformity and CE marking

#### 3.1 System of attestation of conformity

According to the Decision 96/582/EC of the European Commission<sup>9</sup> system 2(i) (referred to as System 1) of the attestation of conformity applies.

This system of attestation of conformity is defined as follows:

System 1: Certification of the conformity of the product by an approved certification body on the basis of:

- (a) Tasks for the manufacturer:
  - (1) factory production control;
  - (2) further testing of samples taken at the factory by the manufacturer in accordance with a prescribed control plan;
- (b) Tasks for the approved body:
  - (3) initial type-testing of the product;
  - (4) initial inspection of factory and of factory production control;
  - (5) continuous surveillance, assessment and approval of factory production control.

Note: Approved bodies are also referred to as "notified bodies".

#### 3.2 Responsibilities

##### 3.2.1 Tasks for the manufacturer

###### 3.2.1.1 Factory production control

The manufacturer shall exercise permanent internal control of production. All the elements, requirements and provisions adopted by the manufacturer shall be documented in a systematic manner in the form of written policies and procedures, including records of results performed. This production control system shall insure that the product is in conformity with this European technical approval.

The manufacturer may only use initial/raw/constituent materials stated in the technical documentation of this European technical approval.

The factory production control shall be in accordance with the control plan which is part of the technical documentation of this European technical approval. The control plan is laid down in the context of the factory production control system operated by the manufacturer and deposited with Deutsches Institut für Bautechnik.<sup>10</sup>

The results of factory production control shall be recorded and evaluated in accordance with the provisions of the control plan.

###### 3.2.1.2 Other tasks for the manufacturer

The manufacturer shall, on the basis of a contract, involve a body which is approved for the tasks referred to in section 3.1 in the field of anchors in order to undertake the actions laid down in section 3.2.2 For this purpose, the control plan referred to in sections 3.2.1.1 and 3.2.2 shall be handed over by the manufacturer to the approved body involved.

<sup>9</sup> Official Journal of the European Communities L 254 of 08.10.1996

<sup>10</sup> The control plan is a confidential part of the European technical approval and only handed over to the approved body involved in the procedure of attestation of conformity. See section 3.2.2.

The manufacturer shall make a declaration of conformity, stating that the construction product is in conformity with the provisions of this European technical approval.

### 3.2.2 Tasks for the approved bodies

The approved body shall perform the

- initial type-testing of the product,
- initial inspection of factory and of factory production control,
- continuous surveillance, assessment and approval of factory production control,

in accordance with the provisions laid down in the control plan.

The approved body shall retain the essential points of its actions referred to above and state the results obtained and conclusions drawn in a written report.

The approved certification body involved by the manufacturer shall issue an EC certificate of conformity of the product stating the conformity with the provisions of this European technical approval.

In cases where the provisions of the European technical approval and its control plan are no longer fulfilled the certification body shall withdraw the certificate of conformity and inform Deutsches Institut für Bautechnik without delay.

### 3.3 CE marking

The CE marking shall be affixed on each packaging of the injection mortar. The letters "CE" shall be followed by the identification number of the approved certification body, where relevant, and be accompanied by the following additional information:

- the name and address of the holder of the approval (legal entity responsible for the manufacture),
- the last two digits of the year in which the CE marking was affixed,
- the number of the EC certificate of conformity for the product,
- the number of the European technical approval,
- the number of the guideline for European technical approval.

## 4 Assumptions under which the fitness of the product for the intended use was favourably assessed

### 4.1 Manufacturing

The European technical approval is issued for the product on the basis of agreed data/information, deposited with Deutsches Institut für Bautechnik, which identifies the product that has been assessed and judged. Changes to the product or production process, which could result in this deposited data/information being incorrect, should be notified to Deutsches Institut für Bautechnik before the changes are introduced. Deutsches Institut für Bautechnik will decide whether or not such changes affect the approval and consequently the validity of the CE marking on the basis of the approval and if so whether further assessment or alterations to the approval shall be necessary.

### 4.2 Drafting

Rebar connections must be designed in keeping with good engineering practice. Considering the loads to be anchored, design calculations and design drawings must be produced which can be checked. At least the following items must be stated in the design drawings:

- grade of concrete strength,
- diameter, drilling technique, concrete cover, spacing and embedment depth of the rebar,

- length  $\ell_v$  and length for markings  $\ell_m$  on the injection extension according to Annex 8,
- Use of a drill guide for anchorages close to the edge (see Annex 10),
- kind of preparation of the joint between building component being connected including the diameter and thickness of concrete layer that has to be removed.

### 4.3 Design

#### 4.3.1 General

The actual position of the reinforcement in the existing structure shall be determined on the basis of the construction documentation and taken into account when designing.

The design of post-installed rebar connections according to Annexes 2 and 3 and determination of the internal section forces to be transferred in the construction joint shall be verified in accordance with EN 1992-1-1:2004. When ascertaining the tensile force in the rebar, allowance shall be made for the statically effective height of the bonded-in reinforcement.

rebar anchor FRA according to Annex 7 shall be designed for the welded-on reinforcement steel BSt 500 S. The length of the bonded-in shaft made of stainless steel may not be accounted as anchorage.

The verification of the immediate local force transfer to the concrete has been provided.

The verification of the transfer of the loads to be anchored to the building component shall be provided.

The spacing between post-installed rebars respectively rebar anchor FRA shall be greater than the minimum of  $5 d_s$  and 50 mm (see Annex 5).

#### 4.3.2 Determination of the basic anchorage length

The required basic anchorage length  $\ell_{b,rqd}$  shall be determined in accordance with EN 1992-1-1, Section 8.4.3:

$$\ell_{b,rqd} = (d_s / 4) (\sigma_{sd} / f_{bd})$$

with:  $d_s$  = diameter of the rebar

$\sigma_{sd}$  = calculated design stress of the rebar

$f_{bd}$  = design value of bond strength according to Annex 10, Table 7

in consideration of the coefficient related to the quality of bond conditions and of the coefficient related to the bar diameter and of the drilling technique

#### 4.3.3 Determination of the design anchorage length

The required design anchorage length  $\ell_{bd}$  shall be determined in accordance with EN 1992-1-1, Section 8.4.4:

$$\ell_{bd} = \alpha_1 \cdot \alpha_2 \cdot \alpha_3 \cdot \alpha_4 \cdot \alpha_5 \ell_{b,rqd} \geq \ell_{b,min}$$

with:  $\ell_{b,rqd}$  = according to section 4.3.2

$\alpha_1$  = 1.0 for straight bars

$\alpha_2$  = 0.7...1.0 calculated acc. to EN 1992-1-1, Table 8.2

$\alpha_3$  = 1.0 because of no transverse reinforcement

$\alpha_4$  = 1.0 because of no welded transverse reinforcement

$\alpha_5$  = 0.7...1.0 for influence of transverse pressure acc. to EN 1992-1-1, Table 8.2

$\ell_{b,min}$  = minimum anchorage length acc. to EN 1992-1-1

= max {0.3  $\ell_{b,rqd}$ ; 10 $d_s$ ; 100 mm} under tension

= max {0.6  $\ell_{b,rqd}$ ; 10 $d_s$ ; 100 mm} under compression

In case of diamond drilling multiply the values by 1.3.

The maximum permissible anchorage depth is given in Annex 8 in relation to the dispenser to be used.

#### 4.3.4 Overlap joints

The required design lap length  $l_0$  shall be determined in accordance with EN 1992-1-1, Section 8.7.3:

$$l_0 = \alpha_1 \cdot \alpha_2 \cdot \alpha_3 \cdot \alpha_5 \cdot \alpha_6 \cdot l_{b,rqd} \geq l_{0,min}$$

with:  $l_{b,rqd}$  = according to Section 4.3.2

$\alpha_1$  = 1.0 for straight bars

$\alpha_2$  = 0.7...1.0 calculated acc. to EN 1992-1-1, Table 8.2

$\alpha_3$  = 1.0 because of no transverse reinforcement

$\alpha_5$  = 0.7...1.0 for influence of transverse pressure acc. to EN 1992-1-1, Table 8.2

$\alpha_6$  = 1.0...1.5 for influence of percentage of lapped bars relative to the total cross-section area acc. to EN 1992-1-1, Table 8.3

$l_{0,min}$  = minimum lap length acc. to EN 1992-1-1

$$= \max \{0.3 \cdot \alpha_6 \cdot l_{b,rqd}; 15d_s; 200 \text{ mm}\}$$

In case of diamond drilling multiply the values by 1.3.

The maximum permissible anchorage depth is given in Annex 8 in relation to the dispenser and the bar diameter to be used.

#### 4.3.5 Embedment depth for overlap joints

Overlap joint for rebars:

For calculation of the effective embedment depth of overlap joints the concrete cover at end-face of bonded-in rebar  $c_1$  shall be considered (see Annex 5, Figure 9):

$$l_v \geq l_0 + c_1$$

with:  $l_0$  = required lap length acc. to Section 4.3.4 and to EN 1992-1-1

$c_1$  = concrete cover at end-face of bonded-in rebar (see Annex 5, Figure 9)

If the clear distance between the overlapping rebars is greater than  $4 d_s$  the lap length shall be enlarged by the difference between the clear distance and  $4 d_s$ .

Overlap joint for rebar anchor FRA:

The effective embedment depth is the same like the lap length  $l_v = l_0$  (see Annex 5, Figure 10).

The total embedment depth  $l_{e,ges}$  shall be determined as follows (see Annex 5, Figure 10):

$$l_{e,ges} \geq l_0 + l_e$$

with:  $l_0$  = required lap length acc. to Section 4.3.4 and to EN 1992-1-1

$l_e$  = length of the smooth shaft ( $l_e > c_1$  see also Annex 7),

If the clear distance between overlapping rods exceeds  $4 d_s$ , the overlap length shall be increased by the difference between the actual clear distance and  $4 d_s$ .

#### 4.3.6 Concrete cover

The concrete cover required for bonded-in rebars and rebar anchor FRA is shown in Annex 10, Table 8, in relation to the drilling method and the hole tolerance.

Furthermore the minimum concrete cover given in EN 1992-1-1, Section 4.4.1.2 shall be observed.

#### 4.3.7 Transverse reinforcement

The requirements of transverse reinforcement in the area of the post-installed rebar connection or of the rebar anchor FRA connection shall comply with EN 1992-1-1, Section 8.7.4.



#### 4.3.8 Connection joint

The transfer of shear forces between new concrete and existing structure shall be designed according to EN 1992-1-1. The joints for concreting must be roughened to at least such an extent that aggregate protrude.

In case of a carbonated surface of the existing concrete structure the carbonated layer shall be removed in the area of the post-installed rebar connection with a diameter of  $d_s + 60$  mm prior to the installation of the new rebar.

The depth of concrete to be removed shall correspond to at least the minimum concrete cover for the respective environmental conditions in accordance with EN 1992-1-1.

The foregoing may be neglected if building components are new and not carbonated and if building components are in dry conditions.

#### 4.4 Installation

The fitness for use of the post-installed rebar connection can only be assumed if the rebar respectively the rebar anchor FRA is installed as follows:

- the installation of post-installed rebar respectively rebar anchor FRA shall be done only by suitable trained installer and under supervision on site; the conditions under which an installer may be considered as suitable trained and the conditions for supervision on site are up to the Member States in which the installation is done,
- use of the injection system only as supplied by the manufacturer without exchanging the components of the Injection system,
- installation in accordance with the manufacturer's specifications and drawings using the tools indicated in the technical documentation of this European technical approval,
- checks before rebar installation to ensure that the strength class of the concrete in which the post-installed rebar connection is to be placed is in the range given and is not lower than that of the concrete to which the characteristic loads apply,
- check of concrete being well compacted, e.g. without significant voids,
- check the position of the existing rebars (if the position of existing rebars is not known, it shall be determined using a rebar detector suitable for this purpose as well as on the basis of the construction documentation and then marked on the building component for the overlap joint),
- keeping the anchorage depth as specified in the design drawings,
- keeping of concrete cover and spacing as specified in the design drawings,
- positioning of the drill holes without damaging the reinforcement,
- in case of aborted drill hole the drill hole shall be filled with mortar,
- the post-installed rebar connection must not be installed in flooded holes,
- the drilling and cleaning of the hole and the installation shall be performed only with the equipment specified by the manufacturer according to the manufacturer's installation instructions (see Annex 10), it shall be ensured that this equipment is available on site and it is used,
- during curing of the injection mortar the temperature of the building component must not be less than  $+5$  °C and no more than  $+40$  °C; observing the curing time given in Annex 8.

## 5 Recommendations concerning packaging, transport and storage

### 5.1 Responsibility of the manufacturer

It is in the responsibility of the manufacturer to ensure that the information on the specific conditions according to sections 1 and 2 including Annexes referred to and section 4 is given to those who are concerned. This information may be made by reproduction of the respective parts of the European technical approval. In addition all installation data shall be shown clearly on the package and/or on an enclosed instruction sheet, preferably using illustration(s).

The minimum data required are:

- drill bit diameter,
- diameter of rebar,
- admissible service temperature range,
- curing time of the injection mortar,
- Installation instructions including cleaning of the drill hole,
- reference to any special installation equipment needed,
- identification of the manufacturing batch,

All data shall be presented in a clear and explicit form.

### 5.2 Packaging, transport and storage

The mortar cartridges shall be protected against sun radiation and shall be stored according to the manufacture's installation instructions in dry condition at temperatures of at least +5 °C to not more than +25 °C.

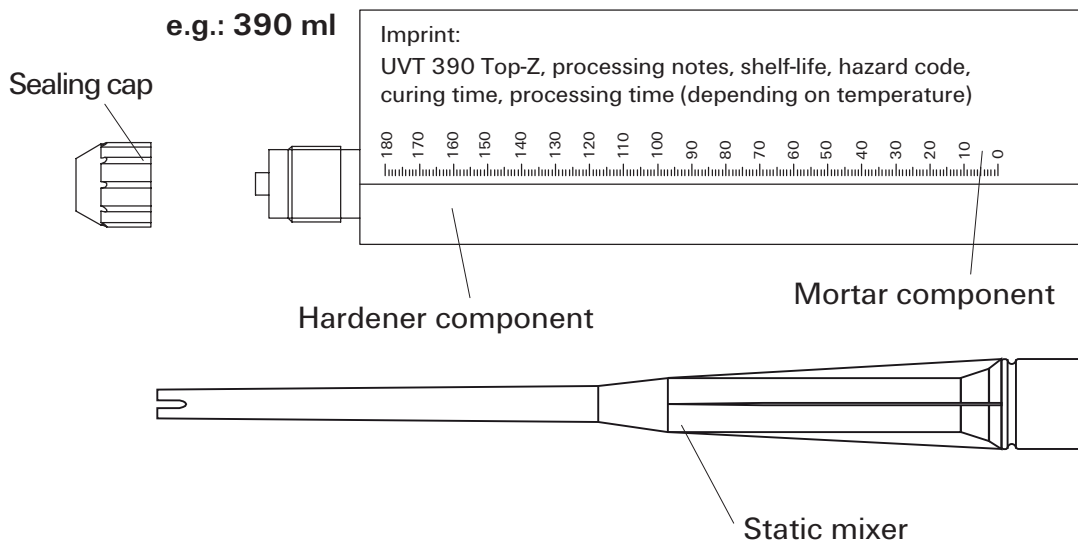
Mortar cartridges with expired shelf life must no longer be used.

Georg Feistel  
Head of Department

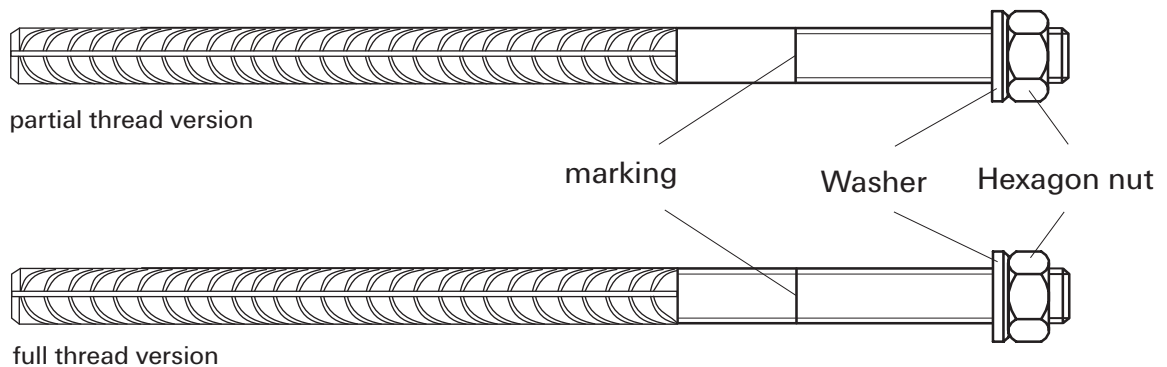
*beglaubigt:*  
Tempel

- Standard concrete C12/15 - C50/60 according to EN 206-1
- Reinforcement bar,  $d_s = 8 \text{ mm} - 40 \text{ mm}$  (properties see Annex 6).
- Rebar anchor FRA 12, FRA 16, FRA 20 (properties see Annex 7).
- Injection mortar UVT 390 Top-Z
- Method for drilling and cleaning the drill holes and the injection of the mortar.

**UVT 390 Top-Z, mortar cartridge 390 ml, 585 ml, 1100 ml**



**Rebar anchor FRA 12, 16, 20**



**Intended use**

Installation in dry and wet concrete. The rebar may be installed downwards or in horizontal position. Rebar sizes  $\leq 25 \text{ mm}$  may also be installed in upward position.

**Temperature range:**

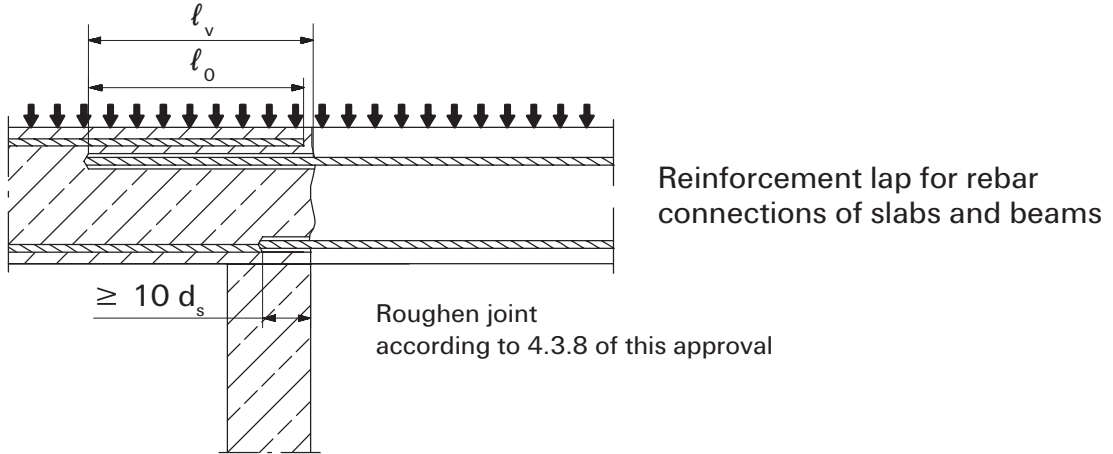
-40°C to + 80°C (max. long term temperature +50°C and  
max. short term temperature +80°C)

Rebar connection with BTI Injection mortar UVT 390 Top-Z

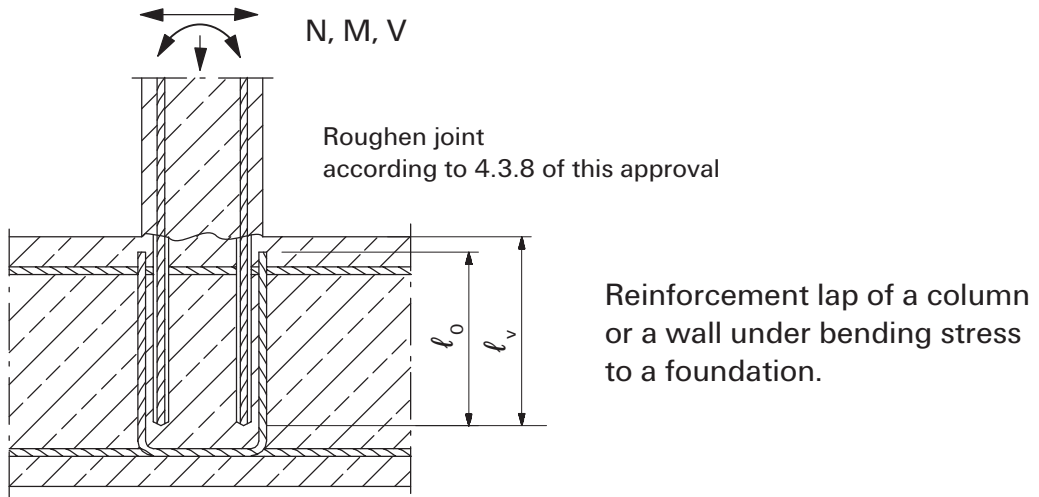
Product and intended use

**Annex 1**  
of European  
technical approval  
**ETA-11/0273**

**Figure 1**

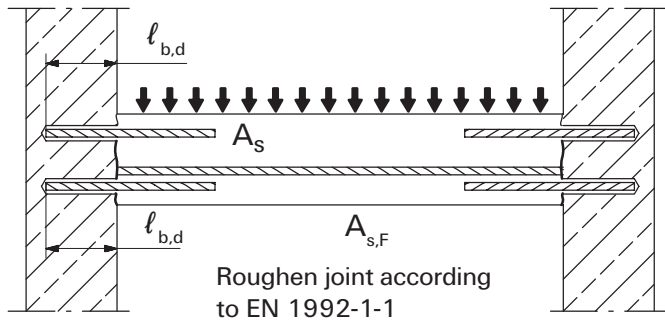


**Figure 2**



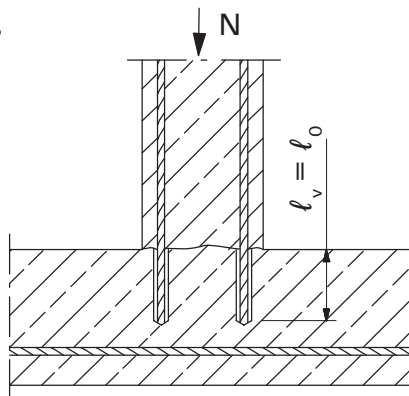
The required transverse reinforcement according to EN 1992-1-1 is not shown in the figures.

**Figure 3**



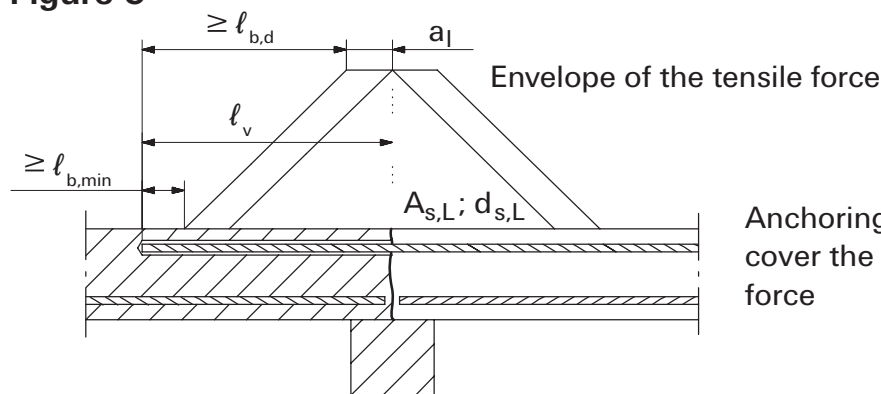
End anchoring of slabs or beams which have been designed as simply supported

**Figure 4**



Rebar connection of building members under predominant pressure

**Figure 5**



Anchoring of reinforcement to cover the envelope of the tensile force

The required transverse reinforcement according to EN 1992-1-1 is not shown in the figures.

Rebar connection with BTI Injection mortar UVT 390 Top-Z

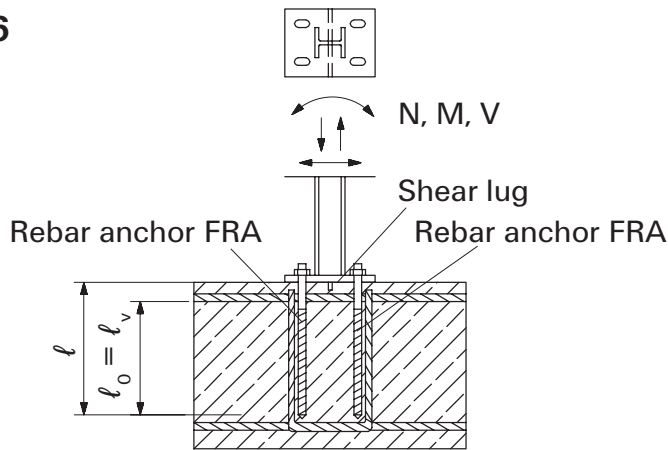
Examples of use for reinforcement bars  
Anchorage

**Annex 3**

of European  
technical approval

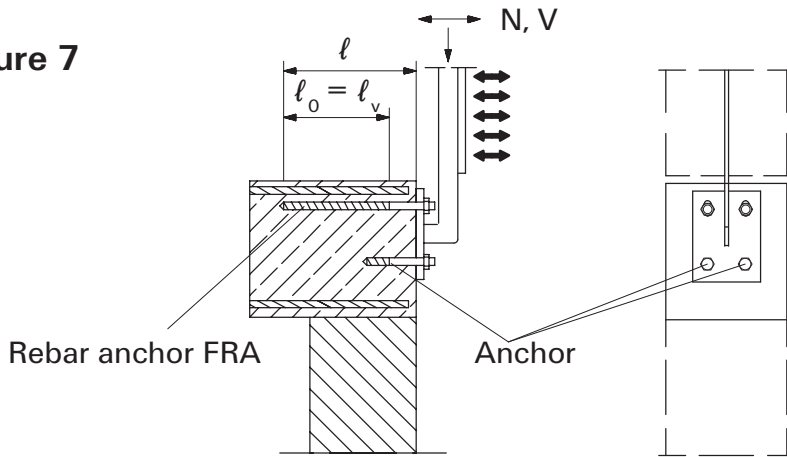
**ETA-11/0273**

**Figure 6**



Lap to a foundation of a column under bending

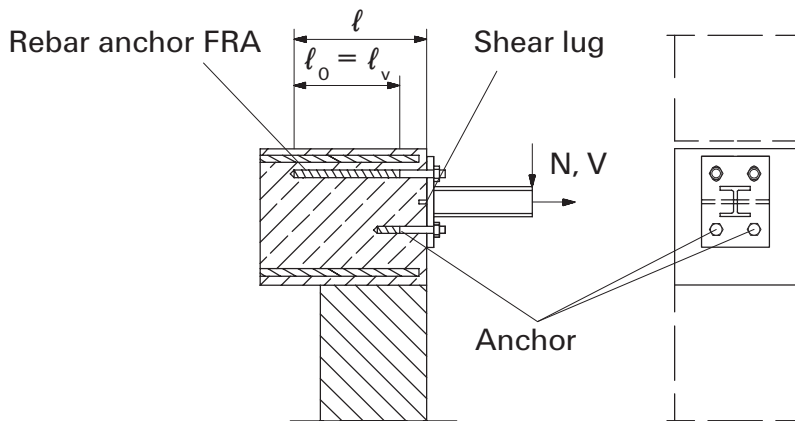
**Figure 7**



Lap for the anchoring of guardrail posts

In the anchor plate, the drill holes for the rebar anchors FRA have to be designed as elongated holes with axial direction to the shear force.

**Figure 8**



Lap of the anchoring of cantilevered building components

In the anchor plate, the drill holes for the rebar anchors FRA have to be designed as elongated holes with axial direction to the shear force.

The required transverse reinforcement according to EN 1992-1-1 is not shown in the figures.

**The rebar anchor FRA may be only used for axial tensile loads.**

The tensile force must be transferred by a lap to the existing reinforcement of the building. The transfer of the shear loads has to be ensured by suitable measure, e.g. by means of shear lugs or anchors with an European technical approval (ETA).

Rebar connection with BTI Injection mortar UVT 390 Top-Z

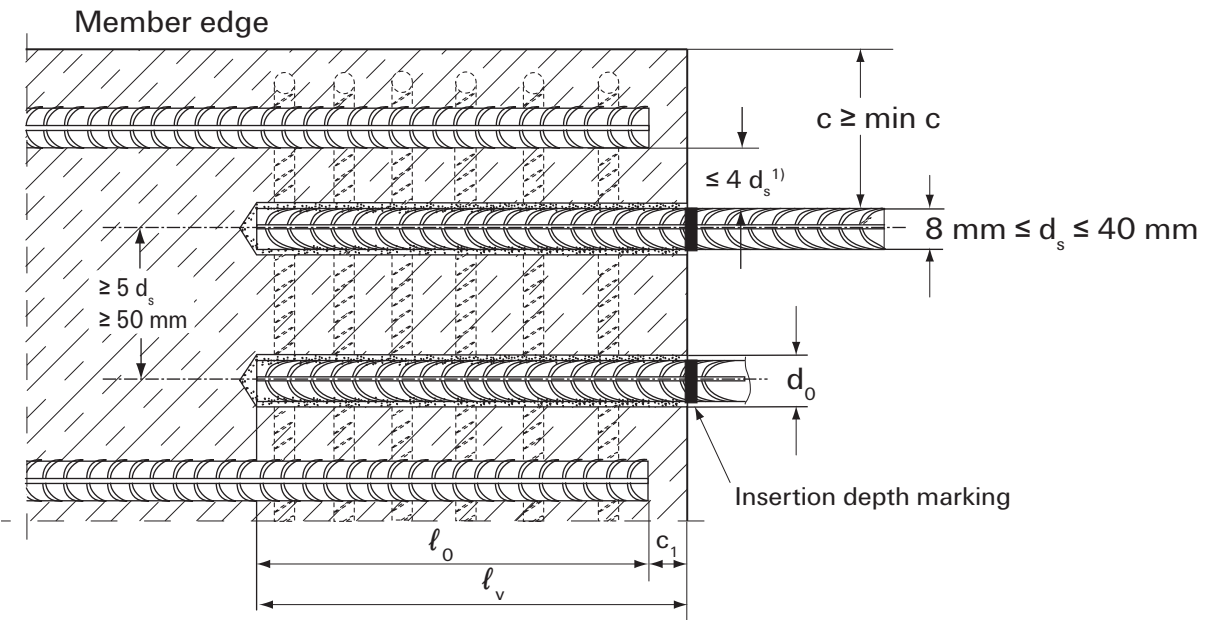
Examples of use for rebar anchors FRA  
Laps

**Annex 4**

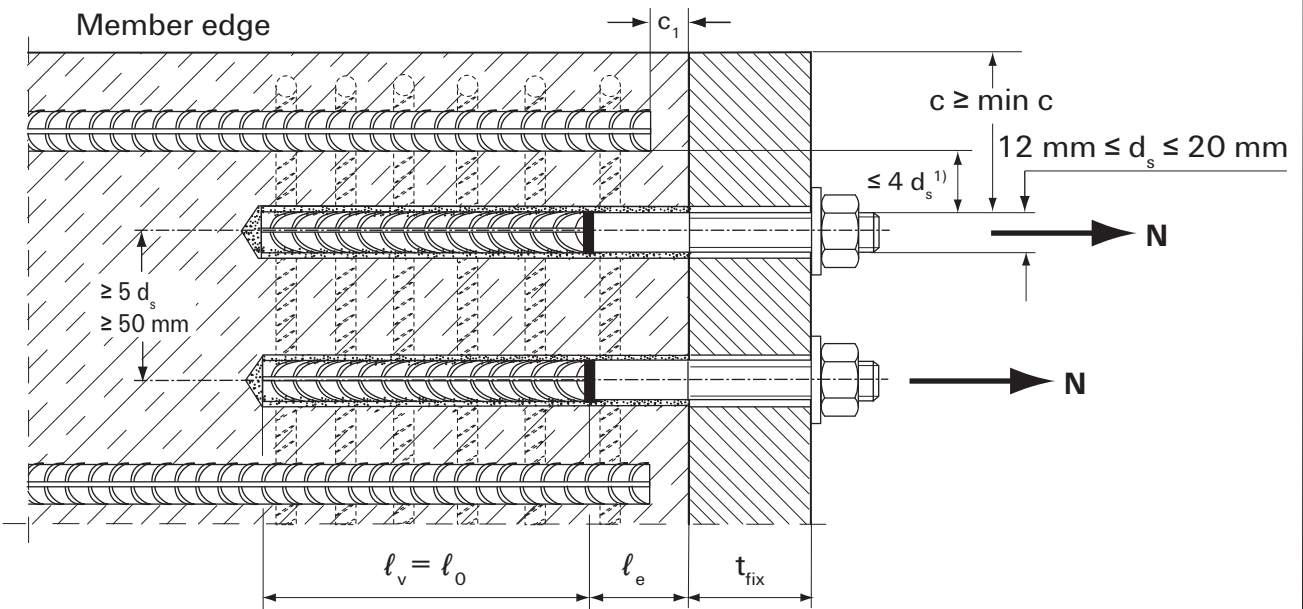
of European  
technical approval

**ETA-11/0273**

**Figure 9: Setting instruction rebar**



**Figure 10: Setting instruction FRA (e.g.: Version with smooth shaft)**



<sup>1)</sup> If the clear distance between lapped bars exceeds  $4d_s$ , then the lap length shall be increased by the difference between the clear bar distance and  $4d_s$ .

- c concrete cover of bonded-in bar
- min c minimum concrete cover according to Section 4.3.6 of this approval
- $c_1$  concrete cover at end-face of bonded-in bar
- $d_s$  diameter of bonded-in bar
- $l_0$  lap length
- $l_v$  effective embedment depth
- $l_e$  length of the smooth shaft
- $d_0$  nominal drill bit diameter, see table 4, annex 8
- $t_{fix}$  minimum thickness of fixture

Rebar connection with BTI Injection mortar UVT 390 Top-Z

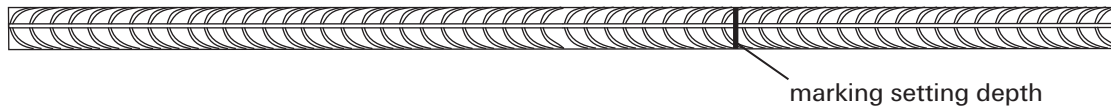
General instruction rules

**Annex 5**

of European  
technical approval

**ETA-11/0273**

**Figure 11: Properties of reinforcing bars „rebars“**



Refer to EN 1992-1-1 Annex C, Table C.1 and C.2N, properties of reinforcement:

Produkt form		Non-zinc-plated bars and de-coiled rod	
Class		B	C
Characteristic yield strength $f_{yk}$ or $f_{0,2k}$ [MPa]		400 to 600	
Minimum value of $k = (f_t/f_y)_k$		$\geq 1,08$	$\geq 1,15$ < 1,35
Characteristic strain at maximum force, $\epsilon_{uk}$ [%]		$\geq 5,0$	$\geq 7,5$
Bendability		Bend / Rebind test	
Maximum deviation from nominal mass (individual bar) [%]	Nominal bar size [mm] $\leq 8$	$\pm 6,0$	
	$> 8$	$\pm 4,5$	
Bond: Minimum relative rib area, $f_{R,min}$ (determination according to EN 15630)	Nominal bar size [mm] 8 to 12	0,040	
	$> 12$	0,056	

**Rib height h:**

The rib height h must be:

$$0,05 \cdot d \leq h \leq 0,07 \cdot d$$

d = nominal bar size

Rebar connection with BTI Injection mortar UVT 390 Top-Z

Properties of rebars

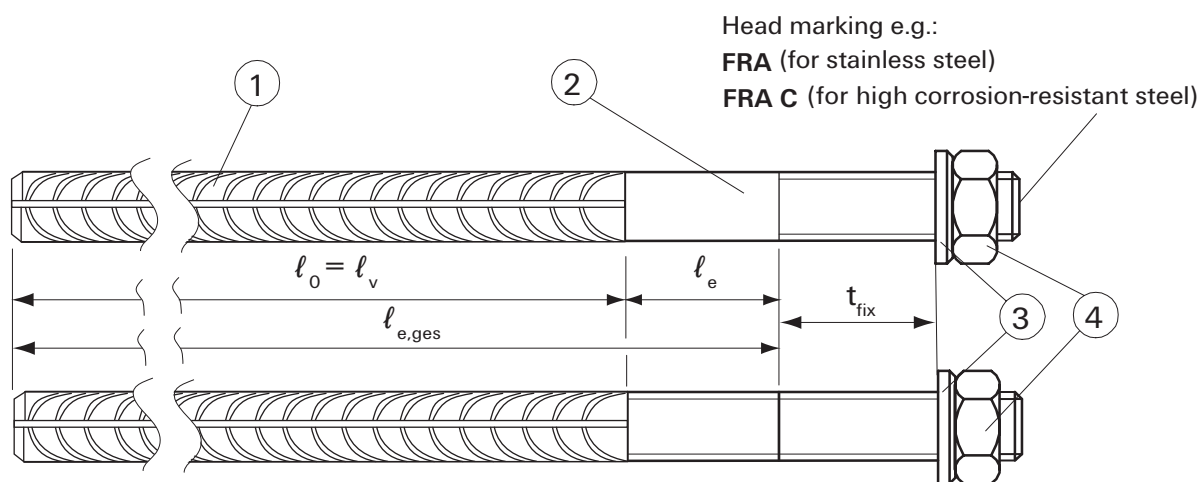
**Annex 6**

of European technical approval

**ETA-11/0273**



**Figure 12: Properties of rebar anchor FRA / FRA C**



**Table 1: Dimensions of rebar anchor FRA and FRA C**

Size	FRA 12/l <sub>e,ges</sub> M12-t <sub>fix</sub>	FRA 16/l <sub>e,ges</sub> M16-t <sub>fix</sub>	FRA 20/l <sub>e,ges</sub> M20-t <sub>fix</sub>
Threaded diameter [mm]	12	16	20
Wrench size [mm]	19	24	30
Total embedment depth l <sub>e,ges</sub> [mm]	l <sub>0</sub> + l <sub>e</sub>		
Effective embedment depth l <sub>v</sub> [mm]	according to statical calculation		
Length of smooth shaft or cast-in thread l <sub>e</sub> [mm]	100		
Minimum thickness of fixure t <sub>fix</sub> [mm]	5		
Maximum thickness of fixure t <sub>fix</sub> [mm]	3000		

**Table 2: Materials of rebar anchor FRA and FRA C**

Part	Description	Materials	
		FRA	FRA C
1	Reinforcing bar	Non-zinc-plated reinforcement bar acc. to EN 1992-1-1	
2	Round bar with partial or full thread	stainless steel according to EN 10088	high corrosion-resistant steel
3	Washer		
4	Hexagon nut	stainless steel according to EN 10088 strength class 80 EN ISO 3506	high corrosion-resistant steel strength class 80 EN ISO 3506

Rebar connection with BTI Injection mortar UVT 390 Top-Z

Properties of FRA  
 Materials FRA

**Annex 7**  
 of European  
 technical approval  
**ETA-11/0273**

**Table 3: Maximum permissible processing times and minimum curing times**

System temperature [°C]	Max. processing time <sup>2)</sup> [minutes]	Minimum curing time <sup>3)</sup> [hours]
+5 to +10 <sup>1)</sup>	120	40
+10 to +20	30	18
+20 to +30	14	10
+30 to +40	7	5

<sup>1)</sup> For installation temperature lower than 10° C the mortar cartridge must be tempered to 20°C.

<sup>2)</sup> Maximum time from the beginning of injection to rebar setting and positioning.

<sup>3)</sup> For wet concrete the curing time must be doubled.

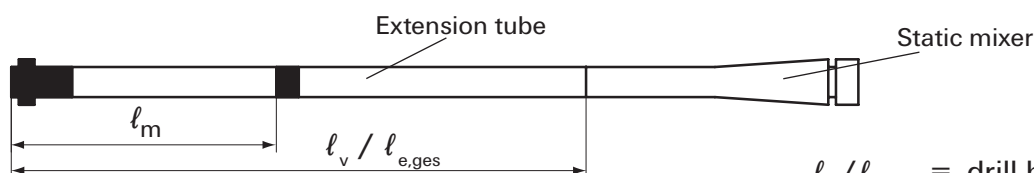
**Table 4: Maximum permissible setting depths**

Bar diameter d <sub>s</sub> [mm]	Nominal drill diameter d <sub>0</sub> [mm]	Diameter of cutting edge d <sub>cut</sub> [mm]	maximum permissible setting depth l <sub>v</sub> [mm]		
			cartridge		1100 ml pneumatic dispenser (large)
			390 ml, 585 ml manual dispenser	Accu and pneumatic dispenser (small)	
8	12	≤ 12,50	1000	1000	1800
10	14	≤ 14,50			
12/FRA 12	16	≤ 16,50			
14	18	≤ 18,50			
16/FRA 16	20	≤ 20,55			
20/FRA 20	25	≤ 25,55	700	1300	2000
22 / 24 / 25	30	≤ 30,55			
26 / 28	35	≤ 35,70	500	700	
30 / 32 / 34	40	≤ 40,70	—	500	
36	45	≤ 45,70			
40	55	≤ 55,70			

**Table 5: Maximum installation torque for fischer rebar anchor FRA**

Rebar anchor	Installation torque T <sub>inst</sub> [Nm]
FRA 12/l <sub>e,ges</sub> M12 - t <sub>fix</sub>	50
FRA 16/l <sub>e,ges</sub> M16 - t <sub>fix</sub>	100
FRA 20/l <sub>e,ges</sub> M20 - t <sub>fix</sub>	150

**Marking length l<sub>m</sub> as factor of the setting depth l<sub>v</sub>**



$l_v / l_{e,ges}$  = drill hole depth  
= minimum length of the extension tube

$l_m$  = length from the end of the injection adapter to the marking on the extension tube

Empirical formula:  $l_m = 1/3 l_v$  or  $l_m = 1/3 l_{e,ges}$  [mm]

Accurate formula:  $l_m = l_v$  or  $l_{e,ges} \left( 1,2 \frac{d_s^2}{d_0^2} - 0,2 \right)$  [mm]

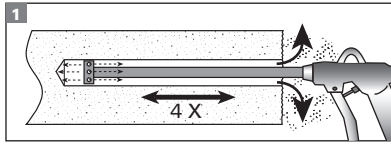
Rebar connection with BTI Injection mortar UVT 390 Top-Z

Processing times and curing times  
Setting depths; Installation torque FRA  
Marking length

**Annex 8**  
of European  
technical approval  
**ETA-11/0273**

## Installing instructions

### Using hammer drill bit or pneumatic drill bit

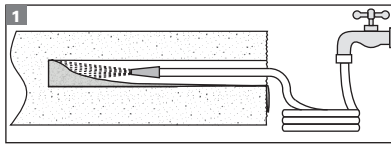


Blow out the drill hole 4 times from the base of the hole with the corresponding cleaning nozzle (oil-free compressed air  $\geq 6$  bar).

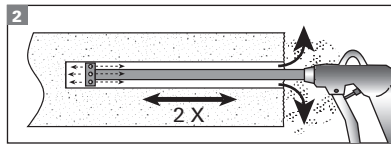
### Using diamond core bit



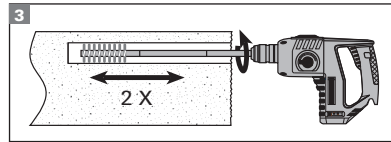
Remove the drill core



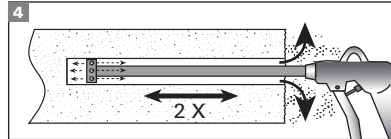
Flush the drill hole with tap water until water runs clear.



Blow out the drill hole 2 times from the base of the hole with the corresponding cleaning nozzle (oil-free compressed air  $\geq 6$  bar).

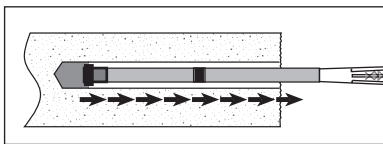


Attach the extension with corresponding stainless steel brush to the power drill. Brush out the drill hole 2 times.



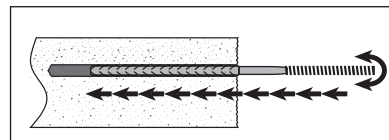
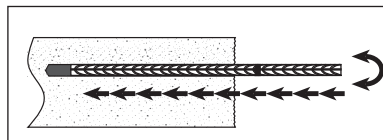
Blow out the drill hole 2 times from the base of the hole with the corresponding cleaning nozzle (oil-free compressed air  $\geq 6$  bar).

### Filling the drill hole



Place mortar cartridge in dispenser. Attach static mixer, extension tube and injection adapter. Slowly withdraw the dispenser - following the pressure build-up - during filling.

### Inserting reinforcement bar



Using a turning movement, push the reinforcement bar vigorously into the filled hole up to the insertion depth marking. Excess mortar has to exit from the drill hole surface. Wait for the specified curing time.

**The rebar may only be loaded after full curing!**

Rebar connection with BTI Injection mortar UVT 390 Top-Z

Installing instructions

**Annex 9**  
of European  
technical approval  
**ETA-11/0273**

**Table 6: Installing equipment**

Rebar diameter $d_s$ [mm]	8	10	12	14	16	18 20	22 24 25	26 28	30 32 34	36	40
Drill hole diameter $d_0$ [mm]	12	14	16	18	20	25	30	35	40	45	55
Brush diameter [mm]	12.5	15	17	19	21.5	26.5	32	37	42	47	58
Cleaning nozzle diameter [mm]	11		15		19		28		38		
Extension tube diameter [mm]	9 <sup>1)</sup>				9 <sup>1)</sup> or 15						
Colour of injection adapter and brush	white	blue	red	yellow	green	black	grey	brown	nature		

<sup>1)</sup> Observe the max. filling depth for the 9 mm extension tube.

**Table 7: Design values of the ultimate bond resistance**

Hammer drill or pneumatic drill <sup>1)</sup>										
	Rebar	C12/15	C16/20	C20/25	C25/30	C30/37	C35/45	C40/50	C45/55	C50/60
$f_{bd}$ [N/mm <sup>2</sup> ]	8-25	1.6	2.0	2.3	2.7	3.0	3.4	3.7	4.0	4.3
	26-40									4.0
Diamond drill <sup>2)</sup>										
	Rebar	C12/15	C16/20	C20/25	C25/30	C30/37	C35/45	C40/50	C45/55	C50/60
$f_{bd}$ [N/mm <sup>2</sup> ]	8-12	1.6	2.0	2.3	2.7	3.0	3.4	3.7	4.0	4.3
	14-25								3.7	
	26-40						3.0			

<sup>1)</sup> Minimum anchorage length and lap length  $l_{b,min}$  and  $l_{0,min}$  according to EN 1992-1-1

<sup>2)</sup> In case of diamond drilling multiply the values for  $l_{b,min}$  and  $l_{0,min}$  by 1.3. (according to EN 1992-1-1)

Note: The values given in Table 7 are valid for „good bond conditions“ as described in EN 1992-1-1. For all other conditions multiply the values by 0.7.

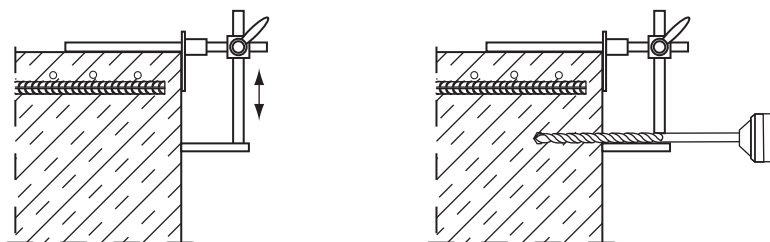
**Table 8: Minimum concrete cover min  $c$ <sup>1)</sup> depending of the drilling method and the drilling tolerance**

Drilling method	Bar diameter $d_s$ [mm]	Minimum concrete cover min $c$	
		without drill guide [mm]	with drill guide [mm]
Hammer drilling/ Diamond drilling	$\leq 20$ mm	30 mm + 0.06 $l_v$	30 mm + 0.02 $l_v \geq 2 d_s$
	$\geq 25$ mm	40 mm + 0.06 $l_v$	40 mm + 0.02 $l_v \geq 2 d_s$
Pneumatic hammer drilling	$\leq 20$ mm	50 mm + 0.08 $l_v$	50 mm + 0.02 $l_v$
	$\geq 25$ mm	60 mm + 0.08 $l_v$	60 mm + 0.02 $l_v$

<sup>1)</sup> see Annex 5, Figures 9 and 10

Note: The minimum concrete cover as specified in EN 1992-1-1 must be observed.

**Drill guide**



Rebar connection with BTI Injection mortar UVT 390 Top-Z

Installing equipment  
Design values  
Concrete cover

**Annex 10**

of European  
technical approval

**ETA-11/0273**