



European Technical Approval ETA-11/0288

English translation prepared by DIBt - Original version in German language

Handelsbezeichnung
Trade name

PFEIFER-DB-Anker-System
PFEIFER DB Anchor System

Zulassungsinhaber
Holder of approval

Pfeifer Seil- und Hebetechnik GmbH
Dr.-Karl-Lenz-Str. 66
87700 Memmingen

Zulassungsgegenstand
und Verwendungszweck
*Generic type and use
of construction product*

Einbetonierter Anker mit Innengewindehülse
Cast-in anchor with internal threaded socket

Geltungsdauer:
Validity: vom
from
bis
to

9 September 2011
9 September 2016

Herstellwerk
Manufacturing plant

Pfeifer Seil- und Hebetechnik GmbH
Dr.-Karl-Lenz-Str. 66
87700 Memmingen

Diese Zulassung umfasst
This Approval contains

24 Seiten einschließlich 16 Anhänge
24 pages including 16 annexes

I LEGAL BASES AND GENERAL CONDITIONS

- 1 This European technical approval is issued by Deutsches Institut für Bautechnik in accordance with:
 - Council Directive 89/106/EEC of 21 December 1988 on the approximation of laws, regulations and administrative provisions of Member States relating to construction products¹, modified by Council Directive 93/68/EEC² and Regulation (EC) N° 1882/2003 of the European Parliament and of the Council³;
 - Gesetz über das In-Verkehr-Bringen von und den freien Warenverkehr mit Bauprodukten zur Umsetzung der Richtlinie 89/106/EWG des Rates vom 21. Dezember 1988 zur Angleichung der Rechts- und Verwaltungsvorschriften der Mitgliedstaaten über Bauprodukte und anderer Rechtsakte der Europäischen Gemeinschaften (Bauproduktengesetz - BauPG) vom 28. April 1998⁴, as amended by law of 31 October 2006⁵;
 - Common Procedural Rules for Requesting, Preparing and the Granting of European technical approvals set out in the Annex to Commission Decision 94/23/EC⁶.
- 2 Deutsches Institut für Bautechnik is authorized to check whether the provisions of this European technical approval are met. Checking may take place in the manufacturing plant. Nevertheless, the responsibility for the conformity of the products to the European technical approval and for their fitness for the intended use remains with the holder of the European technical approval.
- 3 This European technical approval is not to be transferred to manufacturers or agents of manufacturers other than those indicated on page 1, or manufacturing plants other than those indicated on page 1 of this European technical approval.
- 4 This European technical approval may be withdrawn by Deutsches Institut für Bautechnik, in particular pursuant to information by the Commission according to Article 5(1) of Council Directive 89/106/EEC.
- 5 Reproduction of this European technical approval including transmission by electronic means shall be in full. However, partial reproduction can be made with the written consent of Deutsches Institut für Bautechnik. In this case partial reproduction has to be designated as such. Texts and drawings of advertising brochures shall not contradict or misuse the European technical approval.
- 6 The European technical approval is issued by the approval body in its official language. This version corresponds fully to the version circulated within EOTA. Translations into other languages have to be designated as such.

¹ Official Journal of the European Communities L 40, 11 February 1989, p. 12

² Official Journal of the European Communities L 220, 30 August 1993, p. 1

³ Official Journal of the European Union L 284, 31 October 2003, p. 25

⁴ *Bundesgesetzblatt Teil I* 1998, p. 812

⁵ *Bundesgesetzblatt Teil I* 2006, p. 2407, 2416

⁶ Official Journal of the European Communities L 17, 20 January 1994, p. 34

II SPECIFIC CONDITIONS OF THE EUROPEAN TECHNICAL APPROVAL

1 Definition of the product and intended use

1.1 Definition of the construction product

The PFEIFER DB Anchor System in the size of Rd12, Rd16, Rd20, Rd24 and Rd30 is an anchor consisting of an internal threaded socket pressed on a ribbed reinforcement bar.

The socket is made of galvanised steel or stainless steel. The reinforcement bar may be waved (PFEIFER Waved Anchor DB 682) or may be straight with a head pressed on one end (PFEIFER Foot-Mounted Anchor DB 682).

The anchor may be imbedded surface-flush or sunk in the concrete.

An illustration of the product and intended use is given in Annex 1.

1.2 Intended use

The anchor is intended to be used for anchorages for which requirements for mechanical resistance and stability and safety in use in the sense of the Essential Requirements 1 and 4 of Council Directive 89/106/EEC shall be fulfilled and failure of anchorages made with these products would cause risk to human life and/or lead to considerable economic consequences.

The anchor is to be used only for anchorages subject to static or quasi-static loading in reinforced or unreinforced normal weight concrete of strength classes C20/25 at minimum to C50/60 at most according to EN 206-1:2000-12. The anchor may be anchored in cracked and non-cracked concrete.

The anchor may be used for transmission of tensile loads, shear loads or a combination of tensile and shear loads.

The anchor made of galvanised steel in combination with screws made of steel may only be used in structures subject to dry internal conditions. The anchor made of stainless steel in combination with screws made of stainless steel may also be used in structures subject to external atmospheric exposure (including industrial and marine environment) or exposure to permanently damp internal conditions, if no particular aggressive conditions exist. Such particular aggressive conditions are e.g. permanent, alternating immersion in seawater or the splash zone of seawater, chloride atmosphere of indoor swimming pools or atmosphere with extreme chemical pollution (e.g. in desulphurization plants or road tunnels where de-icing materials are used).

The anchor made of galvanised steel may only be used if the inner area of the socket is protected against water during installation. The anchor made of stainless steel may only be used if the ingress of oil into the inner area of the socket is excluded.

The provisions made in this European technical approval are based on an assumed working life of the anchor of 50 years. The indications given on the working life cannot be interpreted as a guarantee given by the producer, but are to be regarded only as a means for choosing the right products in relation to the expected economically reasonable working life of the works.

2 Characteristics of the product and methods of verification

2.1 Characteristics of the product

The anchor corresponds to the drawings and information given in Annex 2 to 4. The characteristic material values, dimensions and tolerances of the anchor not indicated in the Annexes shall correspond to respective values laid down in the technical documentation⁷ of this European technical approval.

Regarding the requirements concerning safety in case of fire it is assumed that the anchor meets the requirements of class A1 in relation to reaction to fire in accordance with the stipulations of the Commission decision 96/603/EC, amended by 2000/605/EC.

The characteristic values for the design of the anchorages are given in Annexes 7 to 14.

The anchor shall be marked with the identifying mark of the producer, the name of the anchor, the size and if applicable additionally with the letters "rostfrei" for stainless steel, e.g. "PFEIFER DB682 Rd12 rostfrei" according to Annex 4.

2.2 Method of verification

2.2.1 General

The assessment of the fitness of the anchor for the intended use with regard to the requirements of mechanical resistance and stability as well as safety in use in the sense of the Essential Requirements 1 and 4 was performed based on the following verifications:

Verifications for tension loads for

- | | |
|---|-----------------------------|
| 1. Steel failure | $N_{Rk,s}$ |
| 2. Steel failure - transfer of setting torque into prestressing force | T_{inst} |
| 3. Concrete failure - pullout | $N_{Rk,p}$ |
| 4. Concrete failure - concrete cone | $N_{Rk,c}$ |
| 5. Concrete failure - splitting due to installation | $c_{min}, s_{min}, h_{min}$ |
| 6. Concrete failure - splitting due to loading | $N_{Rk,sp}$ |
| 7. Displacement under tension loads | $\bar{\delta}_N$ |

Verifications for shear loads for

- | | |
|-------------------------------------|------------------|
| 1. Steel failure without lever arm | $V_{Rk,s}$ |
| 2. Steel failure with lever arm | $M^0_{Rk,s}$ |
| 3. Concrete failure - pry-out | $V_{Rk,cp}$ |
| 4. Concrete failure - concrete edge | $V_{Rk,c}$ |
| 5. Reinforcement | $V_{Rk,c,re}$ |
| 6. Displacement under shear loads | $\bar{\delta}_V$ |

In addition to the specific clauses relating to dangerous substances contained in this European technical approval, there may be other requirements applicable to the products falling within its scope (e.g. transposed European legislation and national laws, regulations and administrative provisions). In order to meet the provisions of the Construction Products Directive, these requirements need also to be complied with, when and where they apply.

⁷ The technical documentation of this European technical approval is deposited at Deutsches Institut für Bautechnik and, as far as it is relevant to the tasks of the approved body involved in the attestation of conformity procedure, is handed over to the approved bodies.

3 Evaluation and attestation of conformity and CE marking

3.1 System of attestation of conformity

According to the Decision 96/582/EC of the European Commission⁸ system 2(i) (referred to as system 1) of the attestation of conformity applies.

This system of attestation of conformity is defined as follows:

System 1: Certification of the conformity of the product by an approved certification body on the basis of:

- (a) Tasks for the manufacturer:
 - (1) factory production control;
 - (2) further testing of samples taken at the factory by the manufacturer in accordance with a prescribed test plan;
- (b) Tasks for the approved body:
 - (3) initial type-testing of the product;
 - (4) initial inspection of factory and of factory production control;
 - (5) continuous surveillance, assessment and approval of factory production control.

Note: Approved bodies are also referred to as "notified bodies".

3.2 Responsibilities

3.2.1 Tasks for the manufacturer

3.2.1.1 Factory production control

The manufacturer shall exercise permanent internal control of production. All the elements, requirements and provisions adopted by the manufacturer shall be documented in a systematic manner in the form of written policies and procedures, including records of results performed. This production control system shall insure that the product is in conformity with this European technical approval.

The manufacturer may only use initial/raw/constituent material stated in the technical documentation of this European technical approval.

The factory production control shall be in accordance with the control plan which is part of the technical documentation of this European technical approval. The control plan is laid down in the context of the factory production control system operated by the manufacturer and deposited with Deutsches Institut für Bautechnik.⁹

The results of factory production control shall be recorded and evaluated in accordance with the provisions of the control plan.

3.2.1.2 Other tasks for the manufacturer

The manufacturer shall, on the basis of a contract, involve a body which is approved for the tasks referred to in section 3.1 in the field of anchors in order to undertake the actions laid down in section 3.2.2. For this purpose, the control plan referred to in sections 3.2.1.1 and 3.2.2 shall be handed over by the manufacturer to the approved body involved.

The manufacturer shall make a declaration of conformity, stating that the construction product is in conformity with the provisions of this European technical approval.

⁸ Official Journal of the European Communities L 254 of 08.10.1996

⁹ The control plan is a confidential part of the European technical approval and only handed over to the approved body involved in the procedure of attestation of conformity. See section 3.2.2.

3.2.2 Tasks for the approved bodies

The approved body shall perform the

- initial type-testing of the product,
- initial inspection of factory and of factory production control,
- continuous surveillance, assessment and approval of factory production control,

in accordance with the provisions laid down in the control plan.

The approved body shall retain the essential points of its actions referred to above and state the results obtained and conclusions drawn in a written report.

The approved certification body involved by the manufacturer shall issue an EC certificate of conformity of the product stating the conformity with the provisions of this European technical approval.

In cases where the provisions of the European technical approval and its control plan are no longer fulfilled the certification body shall withdraw the certificate of conformity and inform Deutsches Institut für Bautechnik without delay.

3.3 CE marking

The CE marking shall be affixed on each packaging of the anchor. The letters "CE" shall be followed by the identification number of the approved certification body, where relevant, and be accompanied by the following additional information:

- the name and address of the producer (legal entity responsible for the manufacture),
- the last two digits of the year in which the CE marking was affixed,
- the number of the EC certificate of conformity for the product,
- the number of the European technical approval,
- size.

4 Assumptions under which the fitness of the product for the intended use was favourably assessed

4.1 Manufacturing

The European technical approval is issued for the product on the basis of agreed data/information, deposited with Deutsches Institut für Bautechnik, which identifies the product that has been assessed and judged. Changes to the product or production process, which could result in this deposited data/information being incorrect, should be notified to Deutsches Institut für Bautechnik before the changes are introduced. Deutsches Institut für Bautechnik will decide whether or not such changes affect the approval and consequently the validity of the CE marking on the basis of the approval and if so whether further assessment or alterations to the approval shall be necessary.

4.2 Design of anchorages

The fitness of the anchor for the intended use is given under the following condition:

The design of the anchorage is based on the CEN/TS 1992-4:2009 "Design of fastenings for use in concrete", part 1 and 2 under the responsibility of an engineer experienced in anchorages and concrete work considering the following difference:

- A supplementary reinforcement for anchors loaded in tension must not be considered in the verifications.

- The verification for shear loading with supplementary reinforcement according section 6.3.1, Table 2, line 6 is not required.
- The resistance $V_{Rk, re}$ for the verification according section 6.3.1, Table 2, line 5 is given in Annex 12 and 13 subject to plane or frontside installation of the reinforcement. Loading may only be in direction of the symmetry axis of the reinforcement.
- Equation (48) is for the verification for combined tension and shear load not applicable. Taking a supplementary reinforcement into account the verification shall follow section 6.4.1.3 with $\beta_V = V_{Ed} / V_{Rd, re}$ and k_7 according Annex 13. The verification for combined tension and shear load shall follow section 6.4.1.1, Equation (46) respectively section 6.4.1.2, Equation (47) additionally.

The screw is chosen with corresponding screw-in depth acc. Annex 7, Table 7 and strength class acc. Annex 9 and 11 subject to the required steel resistance.

The member thickness is not less than h_{min} . The edge distance of the anchors is not less than c_{min} . The spacing of the anchors is not less than s_{min} . All these values are indicated in Annex 8, Table 8 subject to the type of the anchor.

Taking into account the loads to be anchored verifiable calculation notes and drawings are generated.

The position, the type, the size, if applicable the supplementary reinforcement and its direction including the data clip of the anchor and the size, the screw-in depth and the strength class of the screw are indicated on the design drawings. The material of the anchor and the screw shall be given additionally on the drawings.

4.3 Installation of the anchor

The fitness for use of the anchor can only be assumed, if the following installation conditions are observed:

- Installation by appropriately qualified personnel and under the supervision of the person responsible for technical matters on site.
- Use of the anchor only as supplied by the manufacturer without any manipulation or exchanging the components.
- Installation in accordance with the manufacturer's specifications given in Annex 15 and 16 and the design drawings.
- If applicable acc. to the design drawings, orientating the data clip in the direction of the shear load (see also Annex 12 and 13).
- The anchors are fixed on the formwork so that no movement of the anchors will occur during the time of laying the reinforcement and of placing and compacting the concrete.
- The concrete among the anchor and especially under the head of the foot-mounted anchor is properly compacted. The sockets are to be protected from penetration of concrete, for sockets made of galvanised steel of water and for sockets made of stainless steel of oil into the internal space of the sockets.
- Size and strength class of screws corresponding to the design drawings.
- Observation of the prescribed values (e.g. T_{inst} according Annex 7) of installation.
- The setting torques given in Annex 7 must not be exceeded.
- The anchor may only be loaded in the direction shown by the data clip if a supplementary reinforcement is used.

5 Responsibility of the manufacturer

It is in the responsibility of the manufacturer to ensure that the information on the specific conditions according to 1 and 2 including Annexes referred to and 4.2 and 4.3 is given to those who are concerned. This information may be made by reproduction of the respective parts of the European technical approval. In addition all installation data shall be shown clearly on the package and/or on an enclosed instruction sheet, preferably using illustration(s).

The minimum data required are:

- Dimensions of the anchor,
- Material of the socket,
- Mentioning the matching screw,
- Details on the installation procedure, preferably by using illustrations,
- Maximum setting torque,
- Identification of the manufacturing batch.

All data shall be presented in a clear and explicit form.

Georg Feistel
Head of Department

beglaubigt:
Müller

PFEIFER Waved Anchor DB 682

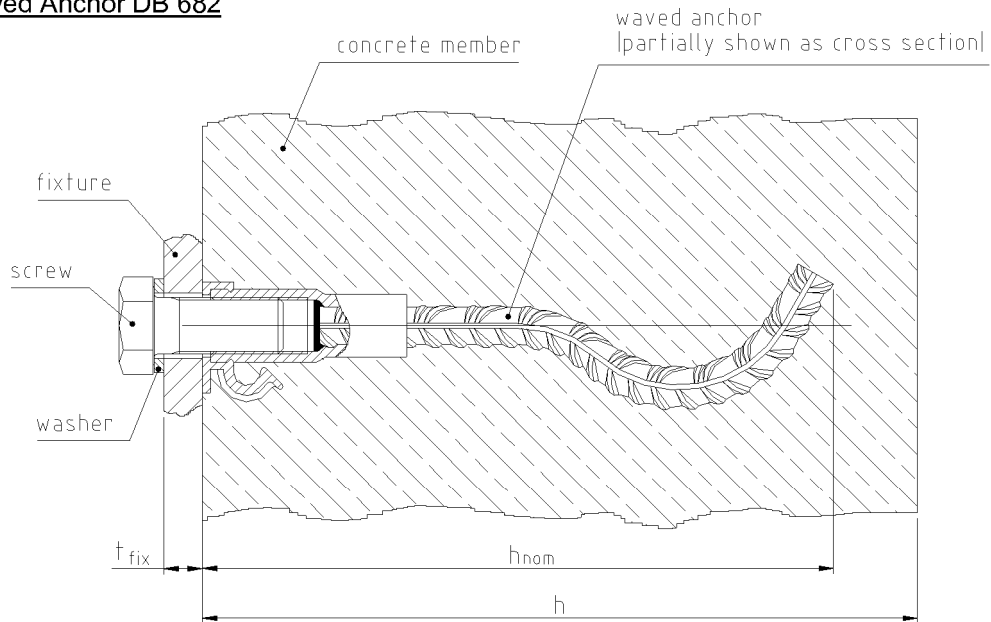

PFEIFER Foot-Mounted Anchor DB 682

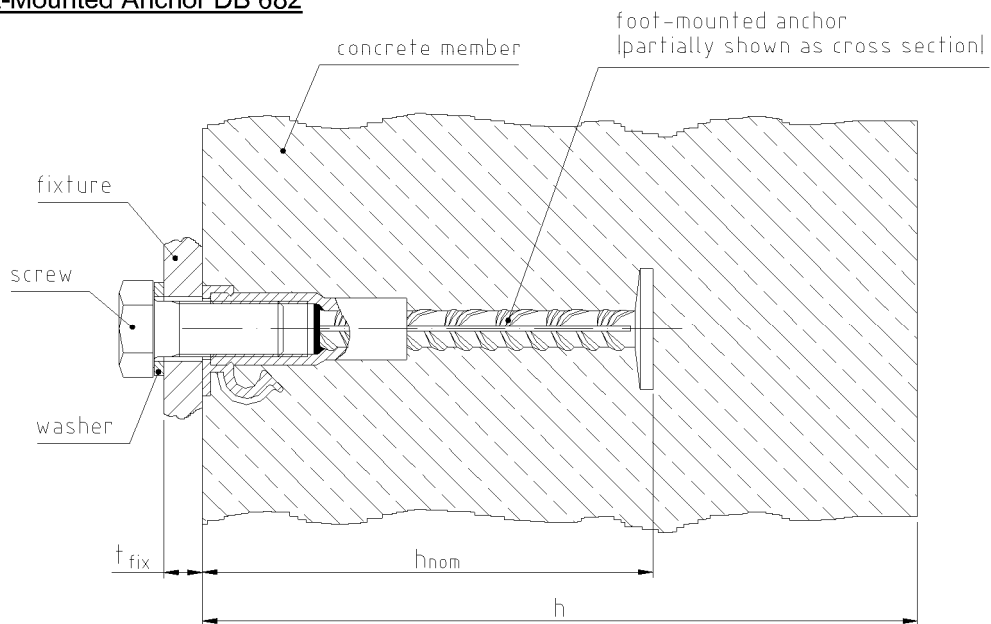

- h = thickness of concrete member
- t_{fix} = thickness of fixture
- t_w = thickness of washer
- h_{nom} = embedment depth
- L_{sd} = screw-in depth
- L_{th} = maximum screw-in depth = length of thread

PFEIFER DB Anchor System

Product and intended use

Annex 1

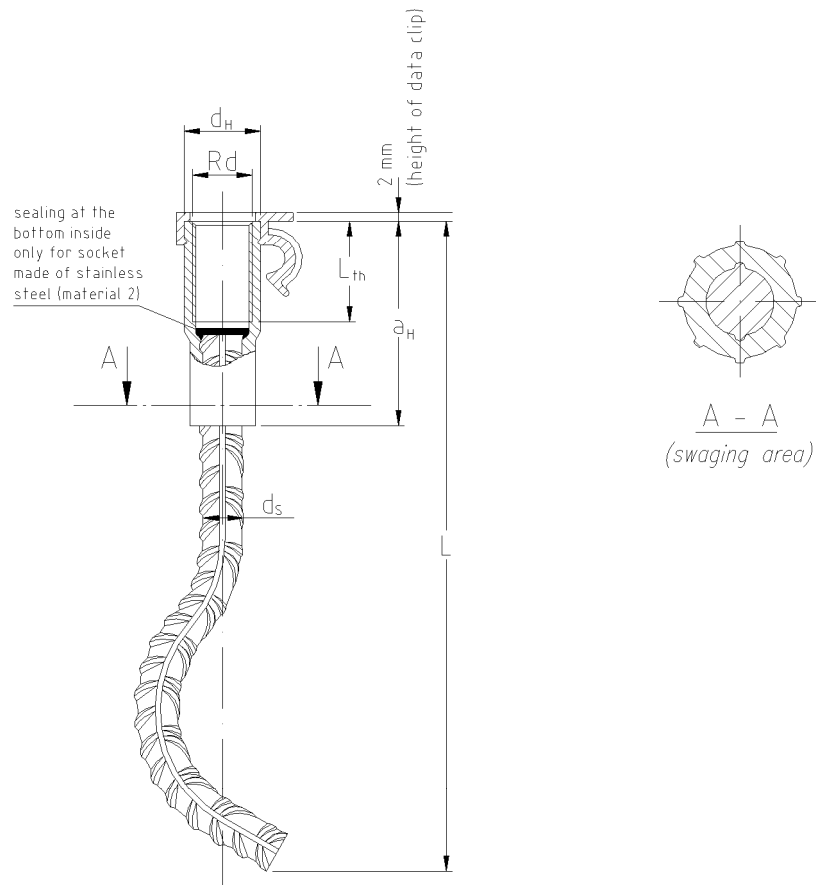

PFEIFER Waved Anchor DB 682 made of two different materials:

Material 1: Socket galvanized steel (thickness $\geq 5 \mu\text{m}$) or

Material 2: Socket stainless steel (1.4571)

Table 1: Dimensions of PFEIFER Waved Anchor DB 682

Waved Anchor DB 682	d_H		a_H	L_{th}	d_s	L
	Material 1	Material 2	Material 1 and Material 2			
	[mm]	[mm]	[mm]	[mm]	[mm]	[mm]
Rd12	15,0	14,8	42,0	22	8	108
Rd16	21,0	21,6	56,5	27	12	172
Rd20	27,2	27,2	72,0	35	16	192
Rd24	31,0	31,0	82,0	43	16	250
Rd30	39,5	39,5	109,5	56	20	300

PFEIFER DB Anchor System

Waved Anchor DB 682

Annex 2

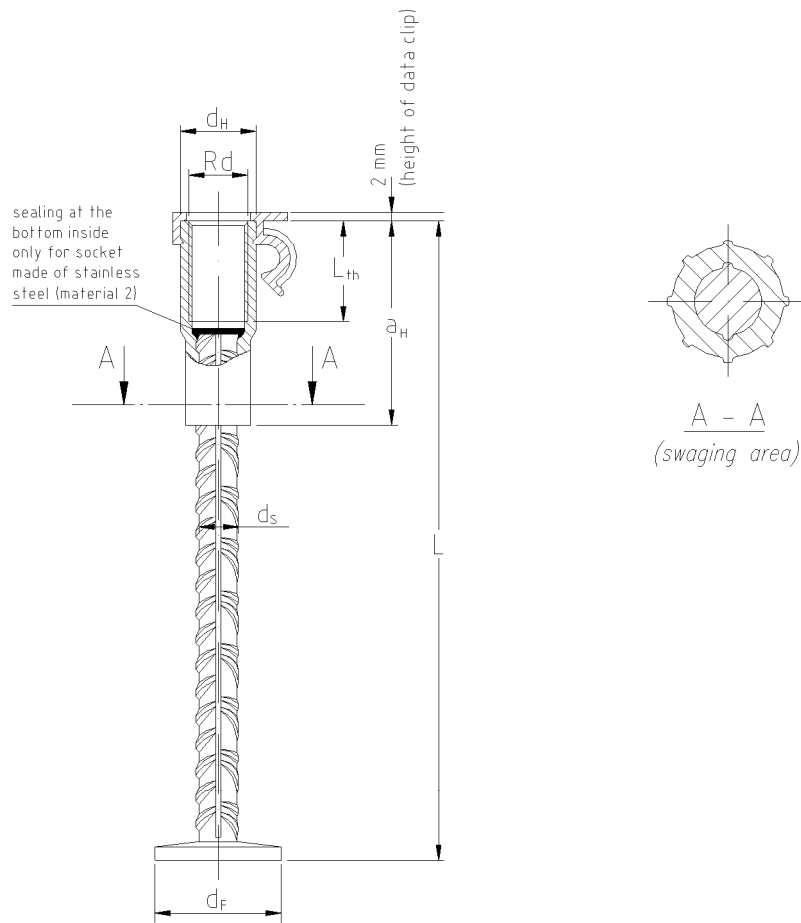

PFEIFER Foot-Mounted Anchor DB 682 made of two different materials:

Material 1: Socket galvanized steel (thickness $\geq 5 \mu\text{m}$) or

Material 2: Socket stainless steel (1.4571)

Table 2: Dimensions of PFEIFER Foot-Mounted Anchor DB 682

Foot-Mounted Anchor DB 682	d_H		a_H	L_{th}	d_s	d_F	L
	Material 1	Material 2	Material 1 and Material 2				
	[mm]	[mm]	[mm]	[mm]	[mm]	[mm]	[mm]
Rd12	15,0	14,8	42,0	22	8	20 - 24	78
Rd16	21,0	21,6	56,5	27	12	30 - 36	118
Rd20	27,2	27,2	72,0	35	16	40 - 48	148
Rd24	31,0	31,0	82,0	43	16	40 - 48	178
Rd30	39,5	39,5	109,5	56	20	50 - 60	218

PFEIFER DB Anchor System

Foot-Mounted Anchor DB 682

Annex 3

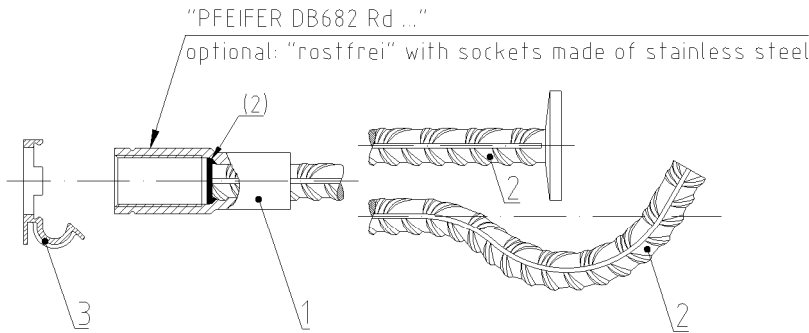

Marking:

e.g.: PFEIFER DB682 Rd12

PFEIFER: Identifying mark of the producer

DB682: Name of the anchor

Rd12: Size

Table 3: Specification and material of the anchors

Item	Component	Material 1 galvanized steel	Material 2 stainless steel
1	Socket	E 355 +N (1,0580) acc. to EN 10305-1/2 galvanized ¹⁾	stainless steel 1.4571 acc. to EN 10215-5 with sealing inside the socket ²⁾
2	Reinforcement Bar	B500A or B500B	
3	Data Clip	Waved Anchor DB 682: Foot-Mounted Anchor DB 682:	Hostalen PPN 1060 RAL 7001 / grey Hostalen PPN 1060 RAL 9010 / white

Table 4: Specification and material of appropriate components (not included in anchor)

Appr. Component	Material associated with anchor of Material 1	Material associated with anchor of Material 2
Washer	Steel acc. to EN 10025, galvanized ¹⁾	Stainless steel 1.4571 acc. to EN 10088
	Geometry acc. to EN ISO 7089/7090	
Screw	Steel acc. to EN ISO 898-1, galvanized ¹⁾ , strength class 5.6 or 8.8	Stainless steel acc. to EN ISO 3506-1, strength class A4-50 or A4-70
Supplementary Reinforcement	B500A or B500B	Reinforcing steel made of stainless steel
	Geometry acc. to Annex 5 (plane installation) or Annex 6 (front-side installation)	

(1) Galvanizing with a plate thickness $\geq 5 \mu\text{m}$ incl. chromate coating (yellow) acc. to EN ISO 4042

(2) Front side of reinforcement bar covered/protected against corrosion

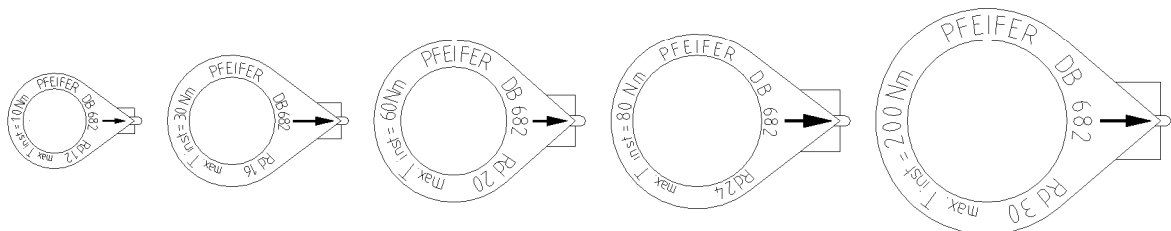

Front view of Data Clip

PFEIFER DB Anchor System

Specification and material

Annex 4

Table 5: Dimensions of supplementary reinforcement for plane installation

		Waved Anchor, Foot-Mounted Anchor				
		Rd12	Rd16	Rd20	Rd24	Rd30
reinforcement B500A, B500B or B500NR	\varnothing_s [mm]	6	8	10	12	12
anchorage length	L_{bd} [mm]	330	440	550	660	660
mandrel diameter	d_{Br} [mm]	24	32	40	48	48
spreading angle	α [°]	30	30	30	30	30

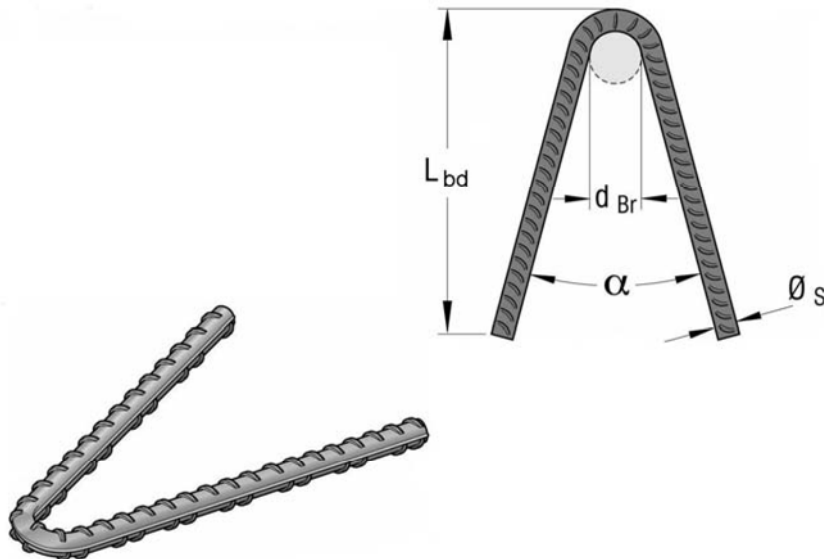

Note

The supplementary reinforcement has to be fixed directly onto the socket by using the data clip. If the anchors are not used under dry internal conditions according to section 1.2, the additional reinforcement has to be made of stainless steel.

PFEIFER DB Anchor System

Supplementary reinforcement for plane installation for shear load

Annex 5

Table 6: Dimensions of the supplementary reinforcement for front-side installation

		Waved Anchor, Foot-Mounted Anchor				
		Rd12	Rd16	Rd20	Rd24	Rd30
reinforcement B500A, B500B or B500NR	\varnothing_{S1} [mm]	6	8	10	12	12
crossbar B500A, B500B or B500NR	\varnothing_{S2} [mm]	8	12	14	14	16
anchorage length	L_{bd} [mm]	270	420	490	520	570
length of crossbar	L_Q [mm]	280	400	490	550	580
overall height	H [mm]	40	55	70	80	105
mandrel diameter	d_{Br} [mm]	24	32	40	48	48
spreading angle	α [°]	15	15	15	15	15

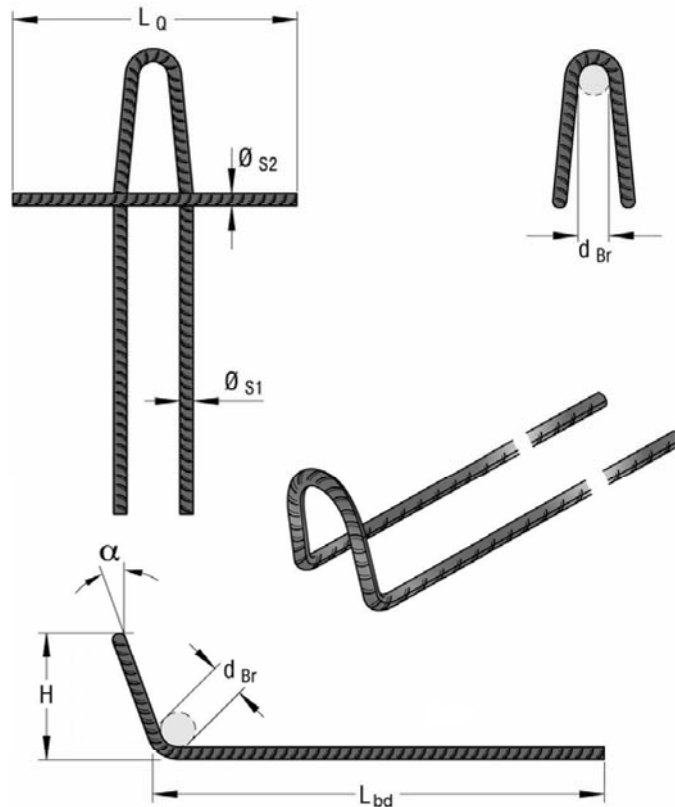

Note

The supplementary reinforcement has to be fixed directly onto the socket by using the data clip. If the anchors are not used under dry internal conditions according to section 1.2, the additional reinforcement has to be made of stainless steel.

PFEIFER DB Anchor System

Supplementary reinforcement for front-side installation for shear load

Annex 6

**Direct steel-to-steel clip
contact**

The fixture is braced directly to the anchor, eventually by using a suitable washer.

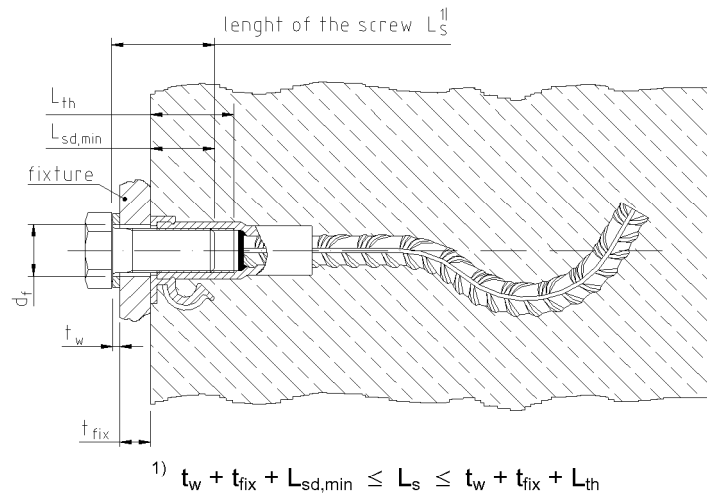

General application

The fixture is braced directly to the concrete while the anchor is either braced surface flush or sunk to the concrete.

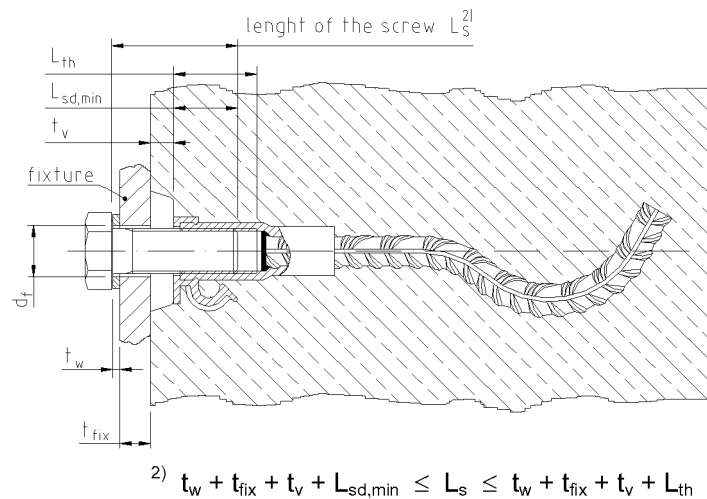

PFEIFER Foot-Mounted Anchors DB 682 may be used analogue

Table 7: Installation parameters

		Waved Anchor DB 682/ Foot-Mounted Anchor DB 682				
		Rd12	Rd16	Rd20	Rd24	Rd30
appropriate size of screw	[mm]	M 12	M 16	M 20	M 24	M 30
maximum setting torque	max. T_{inst} [Nm]	≤ 10	≤ 30	≤ 60	≤ 80	≤ 200
minimum screw-in depth	$L_{sd,min}$ [mm]	15	20	25	30	35
maximum screw-in depth	L_{th} [mm]	24	29	37	45	58
diameter of clearance hole in the fixture	d_f [mm]	14	18	22	26	33

PFEIFER DB Anchor System

Installation paramaters

Annex 7

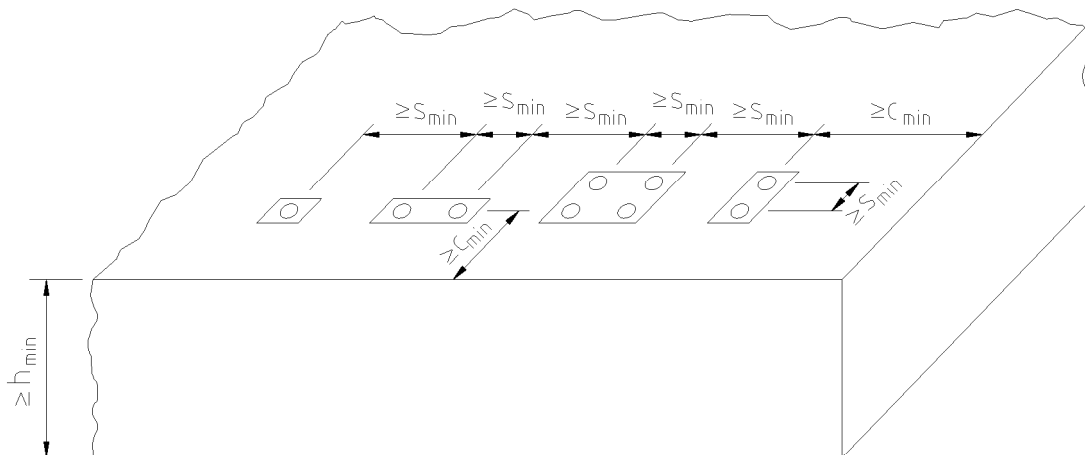

Spacing, edge distance and minimum thickness of concrete member apply also for anchors in front-side installation.

Table 8: Minimum thickness of concrete member, minimum edge distance and minimum spacing

		Waved Anchor DB 682				
		Rd12	Rd16	Rd20	Rd24	Rd30
minimum spacing	s_{min} [mm]	100	120	140	160	200
minimum edge distance	c_{min} [mm]	50	60	70	80	100
minimum thickness of concrete member ¹⁾	h_{min} [mm]	130	200	220	290	340
		Foot-Mounted Anchor DB 682				
		Rd12	Rd16	Rd20	Rd24	Rd30
minimum spacing	s_{min} [mm]	120	150	180	200	240
minimum edge distance	c_{min} [mm]	60	75	90	100	120
minimum thickness of concrete member ¹⁾	h_{min} [mm]	100	140	170	210	250

(1) $h \geq h_{nom} + c_{nom}$ c_{nom} acc. to EN 1992-1

PFEIFER DB Anchor System

Minimum spacings and edge distances, minimum dimensions

Annex 8

Table 9: Characteristic values of resistance for tension load

				Waved Anchor, Foot-Mounted Anchor DB 682				
				Rd12	Rd16	Rd20	Rd24	Rd30
Steel Failure with galvanized sockets and screws (strength class 5.6)								
characteristic resistance	$N_{Rk,s}$	[kN]		31,1	78,5	122,5	110,6	172,8
partial safety factor	$\gamma_{Ms}^{1)}$	[-]		1,66	2,0		1,4	
Steel Failure with galvanized sockets and screws (strength class 8.8)								
characteristic resistance	$N_{Rk,s}$	[kN]		31,1	71,2	130,8	110,6	172,8
partial safety factor	$\gamma_{Ms}^{1)}$	[-]			1,66		1,4	
Steel Failure with sockets and screws made of stainless steel (strength class A4-50)								
characteristic resistance	$N_{Rk,s}$	[kN]		29,4	78,5	122,5	151,1	259,2
partial safety factor	$\gamma_{Ms}^{1)}$	[-]				2,93		
Steel Failure with sockets and screws made of stainless steel (strength class A4-70)								
characteristic resistance	$N_{Rk,s}$	[kN]		29,4	82,6	133,4	151,1	259,2
partial safety factor	$\gamma_{Ms}^{1)}$	[-]				2,93		
Pull-Out Failure								
charact. resistance in cracked concrete	C20/25	$N_{Rk,p}$	[kN]	12	25	50	50	95
charact. resistance in uncracked concrete	C20/25	$N_{Rk,p}$	[kN]	20	40	60	60	95
increasing factor for $N_{Rk,p}$ in cracked or uncracked concrete	C30/37	ψ_c	[-]			1,22		
	C40/50	ψ_c	[-]			1,41		
	C50/60	ψ_c	[-]			1,55		
partial safety factor		$\gamma_{Mp}^{1)}$	[-]			1,50		
Concrete Cone Failure								
effective anchorage depth	Waved Anchor DB 682	h_{ef}	[mm]	54	95	127	140	194
effective anchorage depth	Foot-Mounted Anchor DB 682	h_{ef}	[mm]	78	116	145	175	215
factor to take into account the influence of the load transfer mechanism		k_{cr}	[-]			7,2		
		k_{ucr}	[-]			10,1		
characteristic spacing		$s_{cr,N}$	[mm]			$3,0 \cdot h_{ef}$		
characteristic edge distance		$c_{cr,N}$	[mm]			$1,5 \cdot h_{ef}$		
partial safety factor		$\gamma_{Mc}^{1)}$	[-]			1,50		
Splitting								
effective anchorage depth		h_{ef}	[mm]	54	95	127	140	194
characteristic spacing	Waved Anchor DB 682	$s_{cr,sp}$	[mm]	232	354	368	556	706
characteristic edge distance		$c_{cr,sp}$	[mm]	116	177	184	278	353
effective anchorage depth		h_{ef}	[mm]	78	116	145	175	215
characteristic spacing	Foot-Mounted Anchor DB 682	$s_{cr,sp}$	[mm]	300	460	480	780	900
characteristic edge distance		$c_{cr,sp}$	[mm]	150	230	240	390	450
partial safety factor		$\gamma_{Msp}^{1)}$	[-]			1,50		

(1) In absence of other national regulations

PFEIFER DB Anchor System

Characteristic values of resistance for tension load

Annex 9

Table 10: Displacement under tension load								
				Waved Anchor DB 682				
				Rd12	Rd16	Rd20	Rd24	Rd30
Displacements under tension load								
for waved anchor DB 682 (material 1 or material 2)								
tension load in cracked concrete	N	[kN]		5,7	11,9	23,8	23,8	45,2
short time displacement	δ_{N0}	[mm]		0,6	1,6	1,4	1,3	1,2
long time displacement	$\delta_{N\infty}$	[mm]		1,0	1,9	1,5	1,2	0,9
tension load in uncracked concrete	N	[kN]		9,5	19,1	28,6	28,6	45,2
short time displacement	δ_{N0}	[mm]		0,8	1,7	1,5	1,4	1,2
long time displacement	$\delta_{N\infty}$	[mm]		1,0	1,9	1,5	1,2	0,9
				Foot-Mounted Anchor DB 682				
				Rd12	Rd16	Rd20	Rd24	Rd30
Displacements under tension load								
for foot-mounted anchor DB 682 (material 1 or material 2)								
tension load in cracked concrete	N	[kN]		5,7	11,9	23,8	23,8	45,2
short time displacement	δ_{N0}	[mm]		0,1	0,1	0,2	0,2	0,2
long time displacement	$\delta_{N\infty}$	[mm]		0,2	0,2	0,4	0,4	0,4
tension load in uncracked concrete	N	[kN]		9,5	19,1	28,6	28,6	45,2
short time displacement	δ_{N0}	[mm]		0,1	0,2	0,1	0,2	0,2
long time displacement	$\delta_{N\infty}$	[mm]		0,2	0,4	0,2	0,4	0,4
PFEIFER DB Anchor System				Annex 10				
Displacement under tension load								

Table 11: Characteristic values of resistance for shear load						
		Waved Anchor, Foot-Mounted Anchor DB 682				
		Rd12	Rd16	Rd20	Rd24	Rd30
Shear Load without lever arm						
Steel Failure with galvanized sockets and screws (strength class 5.6)						
characteristic resistance	$V_{Rk,s}$ [kN]	15,5	39,2	61,3	88,3	140,3
partial safety factor	$\gamma_{Ms}^{1)}$ [-]	1,38	1,67			
Steel Failure with galvanized sockets and screws (strength class 8.8)						
characteristic resistance	$V_{Rk,s}$ [kN]	15,5	35,6	65,3	74,1	127,0
partial safety factor	$\gamma_{Ms}^{1)}$ [-]	1,38				
Steel Failure with sockets and screws made of stainless steel (strength class A4-50)						
characteristic resistance	$V_{Rk,s}$ [kN]	14,7	39,2	61,3	75,5	129,6
partial safety factor	$\gamma_{Ms}^{1)}$ [-]	2,44				
Steel Failure with sockets and screws made of stainless steel (strength class A4-70)						
characteristic resistance	$V_{Rk,s}$ [kN]	14,7	41,3	66,7	75,5	129,6
partial safety factor	$\gamma_{Ms}^{1)}$ [-]	2,44				
Shear Load with lever arm						
Steel Failure with galvanized sockets and screws (strength class 5.6)						
characteristic resistance	$M_{Rk,s}^0$ [Nm]	65	166	324	560	1123
partial safety factor	$\gamma_{Ms}^{1)}$ [-]	1,67				
Steel Failure with galvanized sockets and screws (strength class 8.8)						
characteristic resistance	$M_{Rk,s}^0$ [Nm]	115	266	519	896	1797
partial safety factor	$\gamma_{Ms}^{1)}$ [-]	1,38	1,25			
Steel Failure with sockets and screws made of stainless steel (strength class A4-50)						
characteristic resistance	$M_{Rk,s}^0$ [Nm]	65	166	324	560	1123
partial safety factor	$\gamma_{Ms}^{1)}$ [-]	2,44				
Steel Failure with sockets and screws made of stainless steel (strength class A4-70)						
characteristic resistance	$M_{Rk,s}^0$ [Nm]	108	232	454	1123	2422
partial safety factor	$\gamma_{Ms}^{1)}$ [-]	2,44	1,56	2,44		
Concrete Pry-Out Failure						
factor	k [-]	1,0	2,0			
partial safety factor	$\gamma_{Mcp}^{1)}$ [-]	1,50				
Concrete Edge Failure (without supplementary reinforcement)						
effective length of anchor	l_f [mm]	42,0	56,5	72,0	82,0	109,5
outside diameter of anchor	d_{nom} [mm]	15,0	21,0	25,0	25,0	25,0
partial safety factor	$\gamma_{Mce}^{1)}$ [-]	1,50				
(1) In absence of other national regulations						
PFEIFER DB Anchor System					Annex 11	
Characteristic values for shear load						

Table 12: **Characteristic resistance for shear load
due to failure of supplementary reinforcement for plane installation**

			Waved Anchor, Foot-Mounted Anchor DB 682				
			Rd12	Rd16	Rd20	Rd24	Rd30
characteristic resistance of the supplementary reinforcement for plane installation	$V_{Rk, re}$	[kN]	13,5	23,9	37,4	53,8	53,8
corresponding partial safety factor	$\gamma_{Ms, re}^{1)}$	[-]	1,15				
			Waved Anchor DB 682				
minimum spacing	s_{min}	[mm]	100	120	140	160	200
minimum edge distance ²⁾	c_{min}	[mm]	50	60	70	80	100
			Foot-Mounted Anchor DB 682				
minimum spacing	s_{min}	[mm]	120	150	180	200	240
minimum edge distance ²⁾	c_{min}	[mm]	60	75	90	100	120

- (1) In absence of other national regulations
 (2) The edge distance has to be defined with regard to the concrete cover c_{nom} according to EN 1992-1

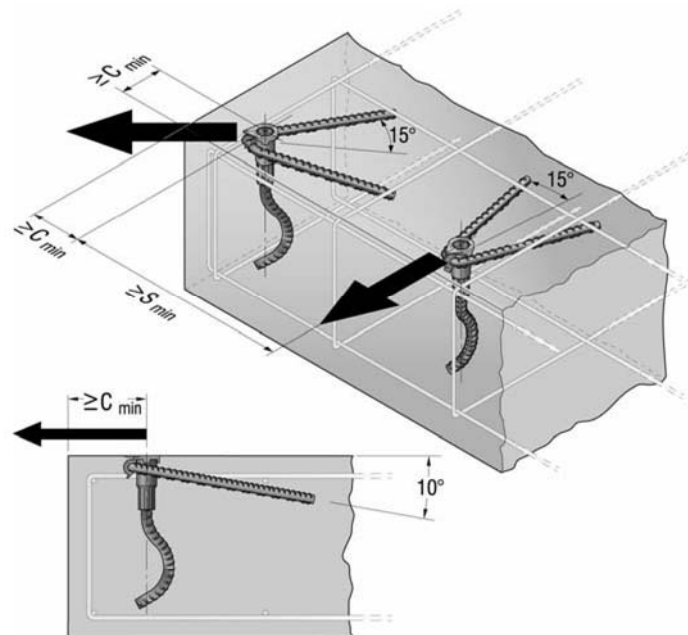

Note

Supplementary reinforcement for plane installation may only be used for forces in direction of the arrows given above. The reinforcement has to be arranged symmetrically to the direction of the force.

The supplementary reinforcement has to be fixed directly onto the socket by using the data clip. If the anchors are not used under dry internal conditions according to section 1.2, the additional reinforcement has to be made of stainless steel.

This information also applies for Foot-Mounted Anchor DB 682.

PFEIFER DB Anchor System	Annex 12
Characteristic resistance for shear load with supplementary reinforcement and plane installation	

Table 13: Characteristic resistance for shear load due to failure of supplementary reinforcement for front-side installation			Waved Anchor, Foot-Mounted Anchor DB 682				
			Rd12	Rd16	Rd20	Rd24	Rd30
characteristic resistance of the supplementary reinforcement for frontside installation	$V_{Rk,re}$ [kN]		5,7	17,6	27,5	39,6	43,0
partial safety factor	$\gamma_{Ms,re}^{1)}$ [-]		1,8				
minimum spacing	$s_{min,H}$ [mm]		280	400	490	550	580
min. edge distance parallel to the plane	$c_{min,H}$ [mm]		$= L_Q / 2 + c_{nom}^{2)}$				
			Waved Anchor DB 682				
min edge distance perpendicular to the plane	c_{min} [mm]		50	60	70	80	100
			Foot-Mounted Anchor DB 682				
min edge distance perpendicular to the plane	c_{min} [mm]		60	75	90	100	120
<p>(1) In absence of other national regulations (2) Dimensions L_Q according to Annex 6</p> 							
Note							
Supplementary reinforcement for front-side installation may only be used for forces in direction of the arrows given above. The reinforcement has to be arranged symmetrically to the direction of the force.							
The supplementary reinforcement has to be fixed directly onto the socket by using the data clip. If the anchors are <u>not</u> used under dry internal conditions according to section 1.2, the additional reinforcement has to be made of stainless steel.							
This information also applies for Foot-Mounted Anchor DB 682.							
Combined tension and shear load							
The faktor k_7 is for combined tension and shear load acc. to CEN/TS 1992-4-2:2009, section 6.4.1.3: $k_7 = 2/3$							
PFEIFER DB Anchor System						Annex 13	
Characteristic resistance for shear force with supplementary reinforcement for front-side installation							

Table 14: Displacement under shear load		Waved Anchor, Foot-Mounted Anchor DB 682				
		Rd12	Rd16	Rd20	Rd24	Rd30
Displacement under shear load <u>without</u> supplementary reinforcement						
with galvanized sockets and screws (strength class 5.6)						
shear load in cracked and uncracked concrete	V [kN]	8,1	16,8	26,2	37,7	60,0
short time displacement	δ_{V0} [mm]	2,0	2,0	3,0	3,0	4,0
long time displacement	$\delta_{V\infty}$ [mm]	3,0	3,0	4,5	4,5	6,0
Displacement under shear load <u>without</u> supplementary reinforcement						
with galvanized sockets and screws (strength class 8.8)						
shear load in cracked and uncracked concrete	V [kN]	8,1	18,4	33,8	38,3	65,8
short time displacement	δ_{V0} [mm]	2,0	2,0	3,0	3,0	4,0
long time displacement	$\delta_{V\infty}$ [mm]	3,0	3,0	4,5	4,5	6,0
Displacement under shear load <u>without</u> supplementary reinforcement						
with sockets and screws made of stainless steel (strength class A4-50)						
shear load in cracked and uncracked concrete	V [kN]	4,3	11,4	17,9	22,1	38,0
short time displacement	δ_{V0} [mm]	2,0	2,0	3,0	3,0	4,0
long time displacement	$\delta_{V\infty}$ [mm]	3,0	3,0	4,5	4,5	6,0
Displacement under shear load <u>without</u> supplementary reinforcement						
with sockets and screws made of stainless steel (strength class A4-70)						
shear load in cracked and uncracked concrete	V [kN]	4,3	12,1	19,5	22,1	38,0
short time displacement	δ_{V0} [mm]	2,0	2,0	3,0	3,0	4,0
long time displacement	$\delta_{V\infty}$ [mm]	3,0	3,0	4,5	4,5	6,0
Displacement under shear load <u>with</u> supplementary reinforcement according to Annex 5 (plane installation)						
shear load in cracked and uncracked concrete	V_S [kN]	8,4	14,8	23,2	33,4	33,4
short time displacement	δ_{V0} [mm]	1,5	1,5	2,0	2,0	2,0
long time displacement	$\delta_{V\infty}$ [mm]	2,0	2,3	2,6	2,7	2,7
Displacement under shear load <u>with</u> supplementary reinforcement according to Annex 6 (front-side installation)						
shear load in cracked and uncracked concrete	V_Q [kN]	2,3	7,0	10,9	15,7	17,1
short time displacement	δ_{V0} [mm]	1,0	1,4	1,6	1,8	2,0
long time displacement	$\delta_{V\infty}$ [mm]	1,5	2,1	2,4	2,7	3,0
PFEIFER DB Anchor System					Annex 14	
Displacement under shear load						

Installation Manual – Part 1

1. Components

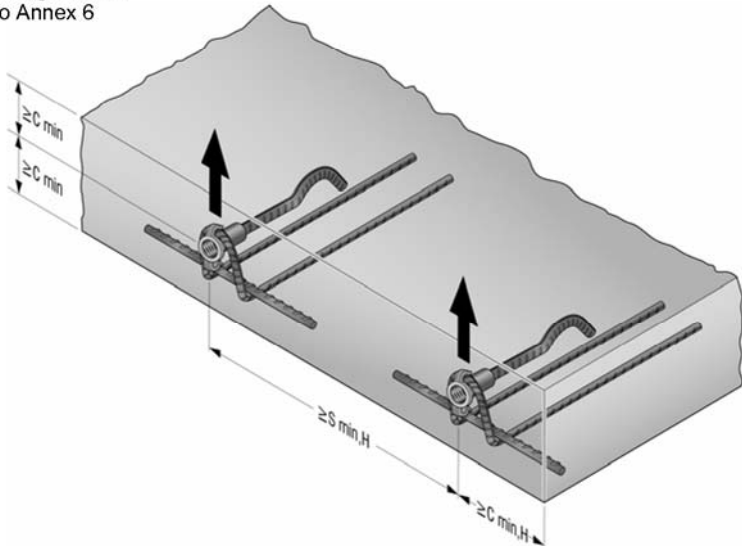
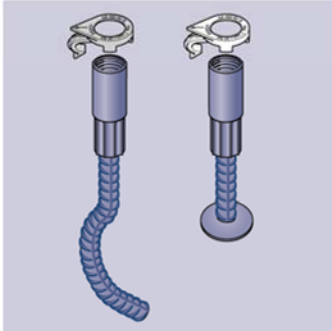

1. PFEIFER Waved Anchor DB 682 or PFEIFER Foot-Mounted Anchor DB 682
with pressed on socket made of galvanized steel or stainless steel
2. PFEIFER Data Clip for Waved Anchor DB 682, colour: grey
PFEIFER Data Clip for Foot-Mounted Anchor DB 682, colour: white

2. Fixing of the anchor at the formwork

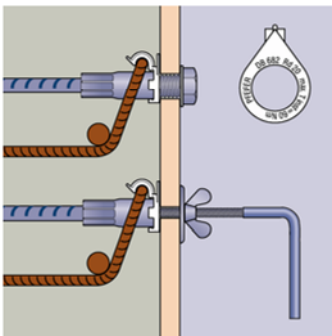

1. Put Data Clip onto the socket.
2. Fix anchor accurately at the formwork by using PFEIFER accessories for shuttering or alternatively by means of a suitable screw.
 - Keep the correct adjustment of the DB anchor!
 - Avoid penetration of concrete, for galvanised sockets of water and for sockets made of stainless steel of oil into the socket!
3. If required, fix supplementary reinforcement acc. to Annex 5 or 6 at the socket by PFEIFER Data Clip and adjust both.
 - Supplementary reinforcement must be fixed in contact with socket!

3. Pouring and compacting the concrete

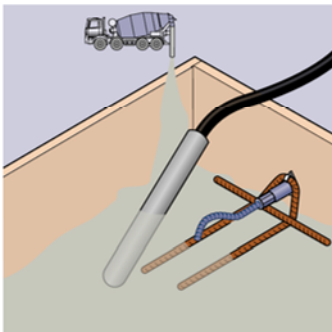

1. Fill in concrete carefully, mind the fixed anchors!
2. Compact concrete properly, avoid contact between vibrating device and DB anchor or supplementary reinforcement.
 - Anchor must not be moved or damaged!

PFEIFER DB Anchor System

Installation Manual – Part 1

Annex 15

Installation Manual – Part 2

4. Removal of shuttering

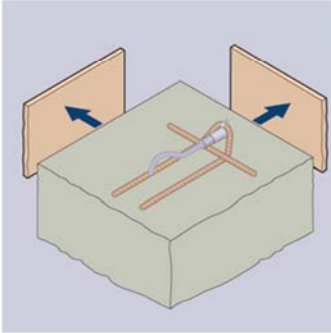

1. Remove accessories for shuttering.
2. Remove shuttering.
3. Check internal thread of DB Anchor for contamination.
Clean the thread of the socket properly if required.

5. Assembly of the fixture

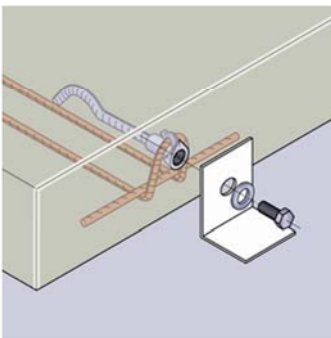

1. Ensure, that the concrete has reached its destined strength.
2. Ensure, that the length of the fastening bolt is correct.
→ Maximum respectively minimum screw-in depth see Annex 7!
3. Assemble the fixture.
→ Use appropriate components acc. to Annex 4, Table 4!
→ Keep the maximum setting torques given below!
→ Note all additional information regarding the fixture!

6. Maximum setting torques

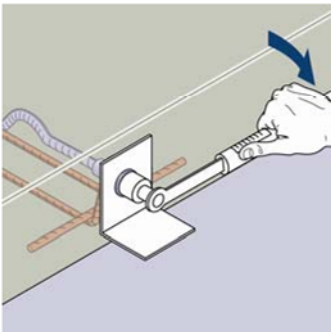

Maximum setting torques max. T_{inst}
for Waved Anchor DB 682/ Foot-Mounted Anchor DB 682

Rd12	Rd16	Rd20	Rd24	Rd30
≤ 10 Nm	≤ 30 Nm	≤ 60 Nm	≤ 80 Nm	≤ 200 Nm

PFEIFER DB Anchor System

Installation Manual – Part 2

Annex 16