



European Technical Approval ETA-11/0402

English translation prepared by DIBt - Original version in German language

Handelsbezeichnung <i>Trade name</i>	WOLF THERMO MODULE
Zulassungsinhaber <i>Holder of approval</i>	WOLF THERMO MODULE GmbH Am Ahlbach 3 97297 Waldbüttelbrunn-Roßbrunn DEUTSCHLAND
Zulassungsgegenstand und Verwendungszweck <i>Generic type and use of construction product</i>	Nicht lasttragender verlorener Schalungsbausatz "WOLF THERMO MODULE" mit Schalungselementen aus EPS <i>Non-load bearing permanent shuttering kit "WOLF THERMO MODULE" based on shuttering elements of EPS</i>
Geltungsdauer: <i>Validity:</i>	vom <i>from</i> bis <i>to</i> 1 December 2011 1 December 2016
Herstellwerk <i>Manufacturing plant</i>	WOLF THERMO MODULE Fabrikstraße 1 74838 Limbach/Krumbach

Diese Zulassung umfasst
This Approval contains

26 Seiten einschließlich 11 Anhänge
26 pages including 11 annexes

I LEGAL BASES AND GENERAL CONDITIONS

- 1 This European technical approval is issued by Deutsches Institut für Bautechnik in accordance with:
 - Council Directive 89/106/EEC of 21 December 1988 on the approximation of laws, regulations and administrative provisions of Member States relating to construction products¹, modified by Council Directive 93/68/EEC² and Regulation (EC) N° 1882/2003 of the European Parliament and of the Council³;
 - *Gesetz über das In-Verkehr-Bringen von und den freien Warenverkehr mit Bauprodukten zur Umsetzung der Richtlinie 89/106/EWG des Rates vom 21. Dezember 1988 zur Angleichung der Rechts- und Verwaltungsvorschriften der Mitgliedstaaten über Bauprodukte und anderer Rechtsakte der Europäischen Gemeinschaften (Bauproduktengesetz - BauPG) vom 28. April 1998⁴, as amended by law of 31 October 2006⁵;*
 - Common Procedural Rules for Requesting, Preparing and the Granting of European technical approvals set out in the Annex to Commission Decision 94/23/EC⁶;
 - Guideline for European technical approval of "Nonload-bearing permanent shuttering systems based on hollow blocks or panels of insulating materials and sometimes concrete", ETAG 009.
- 2 Deutsches Institut für Bautechnik is authorized to check whether the provisions of this European technical approval are met. Checking may take place in the manufacturing plant. Nevertheless, the responsibility for the conformity of the products to the European technical approval and for their fitness for the intended use remains with the holder of the European technical approval.
- 3 This European technical approval is not to be transferred to manufacturers or agents of manufacturers other than those indicated on page 1, or manufacturing plants other than those indicated on page 1 of this European technical approval.
- 4 This European technical approval may be withdrawn by Deutsches Institut für Bautechnik, in particular pursuant to information by the Commission according to Article 5(1) of Council Directive 89/106/EEC.
- 5 Reproduction of this European technical approval including transmission by electronic means shall be in full. However, partial reproduction can be made with the written consent of Deutsches Institut für Bautechnik. In this case partial reproduction has to be designated as such. Texts and drawings of advertising brochures shall not contradict or misuse the European technical approval.
- 6 The European technical approval is issued by the approval body in its official language. This version corresponds fully to the version circulated within EOTA. Translations into other languages have to be designated as such.

¹ Official Journal of the European Communities L 40, 11 February 1989, p. 12
² Official Journal of the European Communities L 220, 30 August 1993, p. 1
³ Official Journal of the European Union L 284, 31 October 2003, p. 25
⁴ *Bundesgesetzblatt Teil I 1998*, p. 812
⁵ *Bundesgesetzblatt Teil I 2006*, p. 2407, 2416
⁶ Official Journal of the European Communities L 17, 20 January 1994, p. 34

II SPECIFIC CONDITIONS OF THE EUROPEAN TECHNICAL APPROVAL

1 Definition of product/ products and intended use

1.1 Definition of the construction product

The shuttering system "WOLF THERMO MODULE" is a non-load-bearing permanent shuttering kit based on shuttering elements of expanded polystyrene (EPS) (see e. g. Annex 1) and accessory parts applicable as formwork for plain and reinforced concrete walls. The accessory parts are spacers of polypropylene (PP-spacers), end stops and lintel shuttering elements.

The shuttering elements are generally used for external load-bearing walls as well as for internal load-bearing walls. The thickness of the inner shuttering leaves is always 62.5 mm and the thickness of the outer shuttering leaves is in the range of 62.5 mm and 297.5 mm. The elements with inner and outer shuttering leaves of 62.5 mm thickness may be applied for internal walls. The thickness of the concrete core is in the range of 125.0 mm and 250.0 mm.

Finishes are not part of the shuttering system "WOLF THERMO MODULE".

1.1.1 Shuttering elements

The shuttering elements consist of inner and outer shuttering leaves and polypropylene-spacers (PP-spacers). These components are assembled on site. The shuttering leaves are one-layered and consist of expanded polystyrene (EPS) inner and outer leaves as well as of PP-spacers. The EPS-shuttering leaves are available in thicknesses of 62.5 mm, 110.0 mm, 172.5 mm, 235.0 mm and 297.5 mm. The length of the elements is in the range of 62.5 mm to 1000.0 mm. The dimension for curved walls is a radius from 1500.0 mm or 3000.0 mm. The height of all elements is 375.0 mm (see Table 1 and e. g. Annex 1).

Table 1: Wall thicknesses of the shuttering elements

Thickness of the wall [mm]	Thickness of EPS-Panels [mm]		Thickness of concrete core [mm]
	inner (d_i)	outer (d_a)	
d	inner (d_i)	outer (d_a)	d_k
250.0	62.5	62.5	125.0
312.5	62.5	110.0	140.0
	62.5	62.5	187.5
375.0	62.5	172.5	140.0
	62.5	62.5	250.0
437.5	62.5	235.0	140.0
500.0	62.5	297.5	140.0

The horizontal top and bottom connecting surface of the shuttering leaves are castellated to allow a tight fit when joined together (see e. g. Annex 1).

The vertical inner surface of shuttering elements consists of a system of tongues and grooves to allow mechanical interlock of the shuttering leaves with the concrete infill as well as mechanical interlock with end stops and lintel shuttering elements.

The accessory parts of EPS are made of the same polystyrene as described in this clause.

1.1.2 Accessory parts

1.1.2.1 End stops

End stops are used to ensure a proper sealing of the end of the shuttering elements. End stops are inserted into the gap between the inner and outer shuttering leaves at the end of the shuttering elements.

1.1.2.2 Lintel shuttering elements

Lintel shuttering elements are put in the gaps between the shuttering leaves and create shuttering elements as lintels. Before concreting the lintel shuttering elements shall be supported. The supports may only be removed after the concrete has hardened sufficiently.

1.2 Intended use

The kit is intended to be used for the construction of internal walls as well as external walls above or below ground which are load-bearing (structural) or non load-bearing (non structural), including those which are subject to fire regulations.

When using this type of construction below ground, a waterproofing according to applicable national rules shall be provided depending on whether ground water not exerting pressure or ground water exerting pressure is to be dealt with. The waterproofing shall be protected from mechanical damage by a smash-resistant protective layer.

The provisions made in this European technical approval are based on an assumed working life of the shuttering kit of 50 years, provided that the conditions laid down in sections 4.2, 5.1 and 5.2 for the packaging, transport, storage, installation, use, maintenance and repair are met. The indications given on the working life cannot be interpreted as a guarantee given by the producer, but are to be regarded only as a means for choosing the right products in relation to the expected economically reasonable working life of the works.

For the intended use it is essential to protect this type of construction against the effects of adverse weather conditions.

2 Characteristics of product and methods of verification

2.1 Characteristics of product

2.1.1 Shuttering elements

The shuttering elements correspond to the specifications and drawings given in the Annexes 1 to 6. The characteristic data of the standard and special shuttering elements are given in the tables of Annexes 1 to 4. The shuttering system consists of the following shuttering elements:

- Standard shuttering elements (Annex 1)
- Corner shuttering elements and T shuttering elements (Annex 2)
- Curved shuttering elements (Annexes 3 and 4)
- End stops (Annex 5)
- Lintel shuttering elements (Annex 5)
- Polypropylene-spacers (Annex 6)

For the shuttering leaves, expanded polystyrene made of polystyrene particle foam EPS - EN 13163 - T1 - L1 - W2 - S1 - P3 - BS150 - CS(10)150 - DS(N)5 - DLT(1)5 according to EN 13163 is used.

The tensile strength of the EPS-leaves perpendicular to faces shall be more than 100 kPa (TR100, according to EN 13163) and the relative changes in length, width and thickness under specified temperature and humidity conditions shall not exceed more than 3 % after exposing them for 48 h at 70 °C (DS(70, -)3, according to EN 13163).

The apparent density ρ_a of the EPS-leaves is in the range between 23 and 30 kg/m³ according EN 13163 and the modulus of shear according EN 12090 shall be at least 1,0 MPa and must not exceed 3,8 MPa.

The declared value of thermal conductivity is $\lambda_D = 0.035$ W/(m K) according EN 13163.

The spacers are moulded of polypropylene (PP-spacers).

The tensile strength of the PP-spacers shall be at least 2150 N and the pull-out strength between PP-spacers and EPS-shuttering leaves shall be at least 1080 N.

The material characteristics, dimensions and tolerances of the shuttering elements not indicated in Annexes 1 to 6 are given in the technical documentation⁷ of the ETA.

2.1.2 Accessory parts

2.1.2.1 End stops

End stops are made of the same EPS material as the shuttering leaves with a thickness of 58.0 mm and a height of 375.0 mm. The width is between 125.0 mm and 250.0 mm, depending of the thickness of the concrete core (see Annex 5). The vertical inner surface of the end stops consists of a system of tongues and grooves.

2.1.2.2 Lintel shuttering elements

Lintel shuttering elements are made of the same EPS material as the shuttering leaves with a height between 125.0 mm and 187.5 mm. The width is between 125.0 mm and 250.0 mm depending on the thickness of the concrete core. The length is 1000.0 mm (see Annex 5). The vertical inner surface of lintel shuttering elements consists of a system of tongues and grooves.

2.2 Methods of verification

2.2.1 General

The assessment of the fitness of the shuttering system for the intended use has been made in compliance with ETAG 009, Guideline for European technical approval of "Non load bearing permanent shuttering kits/systems based on shuttering elements or blocks of insulating materials and sometimes concrete", edition June 2002.

The ETA is issued for the shuttering kit "WOLF THERMO MODULE" on the basis of agreed information, deposited with Deutsches Institut für Bautechnik (DIBt), which identifies the shuttering kit that has been assessed and evaluated. Changes to the production process, the kit or the components which could result in this deposited information being incorrect, shall be notified to DIBt before the changes are introduced. DIBt will decide whether or not such changes affect the ETA and consequently the validity of the CE marking on the basis of the ETA, and, if so, whether further assessment and/or alterations to the ETA shall be necessary.

⁷

The technical documentation of the ETA is deposited with DIBt and, as far as relevant for the tasks of the approved bodies involved in the attestation of conformity procedure, is handed over to the approved bodies.

2.2.2 Essential Requirement 1: Mechanical resistance and stability

2.2.2.1 Resulting structural pattern

In end use conditions walls made with shuttering elements "WOLF THERMO MODULE" are walls of a continuous type according to ETAG 009, chapter 2.2.

2.2.2.2 Efficiency of filling

Considering the instructions of chapter 4.2 and the installation guide of the ETA holder, the efficient filling without bursting of the shuttering and without voids or any uncovered reinforcement in the concrete core is possible.

The requirements according to ETAG 009, chapter 6.1.2 are met satisfactorily.

2.2.2.3 Possibility of steel reinforcement

The instructions in the installation guide of the ETA holder are appropriate to install steel reinforcement for walls according to EN 1992-1-1 or corresponding national rules.

The requirements according to ETAG 009, chapter 6.1.3 are met satisfactorily.

2.2.3 Essential Requirement 2: Safety in case of fire

2.2.3.1 Reaction to fire

Shuttering elements "WOLF THERMO MODULE" made of expanded polystyrene (EPS) according EN 13163 fulfill the requirement of class E according to EN 13501-18.

2.2.3.2 Resistance to fire

The walls will be exposed to the fire on only one site.

According to ETAG 009, Annex C, Table 1, for a continuous type of load-bearing walls ("REI") or non load bearing walls ("EI") and a minimum concrete strength of C16/20 the system meets the criterias "REI" and "EI" as follows (see Table 2).

Table 2: Determination of "REI" of load bearing wall and "EI" of non load bearing walls

Thickness of concrete core [mm]	"REI" according to ETAG 009, Annex C, Table 1	"EI" according to ETAG 009, Annex C, Table 1
125.0	90	120
140.0		
187.5	120	
250.0		

To classify the shuttering elements of the criteria stated in the table above the following preconditions have to be fulfilled according to Annex C of the ETAG 009.

- The design of the building has to take into consideration the secondary effects of fire. Especially constraints, introduced by thermal strain, should be sufficiently low and appropriate building joints should be foreseen. The rules valid in place of use, govern. Structural requirements under normal conditions, valid in the place of use, may require larger dimensions. Concrete cover for the reinforcement has to be observed according to the rules valid in the place of use.
- A normal weight concrete as defined in EN 206-1 or EN 1992-1-1 shall be used. As far as European standards EN 206-1 or EN 1992-1-1 are not in force, an equivalent concrete according to national rules, valid in the place of use, is acceptable.
- The strength of concrete shall be between C 16/20 and C 50/60 according to EN 206-1. In lack of availability of European standard EN 206-1, alternatively a concrete according to national rules, valid in the place of use, with a compressive strength which fits in the interval given above, is also considered as appropriate.

Note: The classifications of the walls constructed with the shuttering system "WOLF THERMO MODULE" regarding to fire resistance are valid only for walls without openings (for windows or doors for examples).

2.2.4 Essential Requirement 3: Hygiene, health and the environment

2.2.4.1 Content and/or release of dangerous substances

The chemical composition of the shuttering system/kit must agree with the deposited version by DIBt.⁹

Note: The shuttering elements made of expanded polystyrene contain a substance included in Annex XIV of the Regulation (EC) No 1907/2006 (REACH).

2.2.4.2 Water vapour permeability

The tabulated value of the water vapour diffusion resistance coefficient of expanded polystyrene (EPS), according to EN ISO 10456 is $\mu = 60$.

Using this value to verify the annual moisture balance or the maximum amount of interstitial condensation according to EN ISO 13788 will be on the safe side.

The values for the water vapour diffusion resistance of concrete depending on density and type are tabulated in EN ISO 10456.

2.2.4.3 Water absorption

The requirements according to ETAG 009, chapter 6.3.3 are met satisfactorily.

2.2.4.4 Watertightness

Because finishes are not part of the shuttering system "WOLF THERMO MODULE" the "No performance determined" option in ETAG 009, Table 3 is used.

⁹

In addition to the specific clauses relating to dangerous substances contained in this European technical approval, there may be other requirements applicable to the products falling within its scope (e. g. transposed European legislation and national laws, regulations and administrative provisions). In order to meet the provisions of the Construction Products Directive, these requirements need also to be complied with, when and where they apply.

2.2.5 Essential Requirement 4: Safety in use**2.2.5.1 Bond strength and resistance to impact load**

Under end use conditions the EPS-leaves are durable fixed by the PP-spacers. The bond strength is at least equal to the resisting concrete pressure of the shuttering elements to clause 2.2.5.2, furthermore the vertical inner surface of shuttering elements consists of a system of tongues and grooves to allow mechanical interlock of the shuttering leaves with the concrete infill.

Concrete walls (without consideration of the finishes), erected with shuttering system "WOLF THERMO MODULE" and designed according EN 1992-1-1 respectively in lack of availability of EN 1992-1-1 according national design rules, lead to the assumption that concrete infill insures an adequate resistance of the complete wall under normal used impact loads.

The requirements according to ETAG 009, chapter 6.4.1 are met satisfactorily.

2.2.5.2 Resistance to filling pressure

To resist the filling pressure the bending tensile strength of the EPS-shuttering leaves shall be more than 150 kPa (BS150 - see also designation code of EPS in clause 2.1.1). The tensile strength of the PP-spacers shall be at least 2150 N and the pull-out strength between PP-spacers and EPS-shuttering leaves shall be at least 1080 N.

The requirements according to ETAG 009, chapter 6.4.2 are met satisfactorily.

2.2.5.3 Safety against personal injury by contact

Delivered on site, the shuttering elements do not have sharp or cutting edges.

Because of the soft surface of the shuttering leaves there is no risk of abrasion or of cutting people.

The requirements according to ETAG 009, chapter 6.4.3 are met satisfactorily.

2.2.6 Essential Requirement 5: Protection against noise**2.2.6.1 Airborne sound insulation**

The "No performance determined" option in ETAG 009, Table 3 is used.

2.2.6.2 Sound absorption

The "No performance determined" option in ETAG 009, Table 3 is used.

2.2.7 Essential Requirement 6: Energy economy and heat retention**2.2.7.1 Thermal resistance**

Assuming a minimal declared value of thermal conductivity of $\lambda_D = 0.035 \text{ W/(m K)}$, see clause 2.1.1, for the expanded polystyrene and for concrete infill of $\lambda_D = 2.3 \text{ W/(m K)}$ (according to EN ISO 10456) the values of declared thermal resistance of the shuttering elements have been determined by numerical calculations. Table 3 gives the declared values of thermal resistance R_D .

Table 3: Declared values of thermal resistance R_D calculated according to EN ISO 6946, clause 6 as multilayered construct product (with concrete infill without rendering and without consideration of PP-spacer) depending on the thickness of the outer leaf of expanded polystyrene and thickness of concrete core.

Type of shuttering element	All-over wall thickness	Thickness of concrete core	Thickness of the inner shuttering EPS-leaf	Thickness of the outer shuttering EPS-leaf	Declared value of thermal resistance
according to ETA, Annex 1	d [mm]	d_k [mm]	d_i [mm]	d_a [mm]	R_D [(m ² K)/W]
G length-250	250.0	125.0	62.5	62.5	3.626
G length-312	312.5	140.0	62.5	110.0	4.989
G length-312/187	312.5	187.5	62.5	62.5	3.653
G length-375	375.0	250.0	62.5	62.5	3.680
G 1000-375	375.0	140.0	62.5	172.5	6.775
G length-437	437.5	140.0	62.5	235.0	8.561
G 1000-500	500.0	140.0	62.5	297.5	10.347

The planner shall consider accessory parts made of steel as thermal bridges, where relevant, for determination of the thermal resistance.

2.2.7.2 Influence of moisture transfer on insulating capacity of the wall

The requirements according to ETAG 009, chapter 6.6.2 are met satisfactorily.

2.2.7.3 Thermal inertia

The values for heat capacity of concrete and expanded polystyrene are tabulated in EN ISO 10456.

2.2.8 Aspects of durability and serviceability

2.2.8.1 Resistance to deterioration

Physical agent

The relative changes of the EPS-leaves (see chapter 2.1.1) in length, width and thickness under specified temperature and humidity conditions shall not exceed more than 3 % after exposing them for 48 h at 70 °C (DS(70, -)3, according to EN 13163).

The requirements according to ETAG 009, chapter 6.7.1.1 are met satisfactorily.

Chemical agent

Spacers are made of polypropylene. There is no corrosion of spacer in concrete.

The finishes of the wall are not part of the ETA. Determination of the cleaning agent of the surface is not possible.

The requirements according to ETAG 009, chapter 6.7.1.2 are met satisfactorily.

Biological agent

The application of EPS as thermal insulating material for decades has shown that it sufficiently protects against fungi, bacteria, algae and insects.

EPS does not provide a food value and in general it does not contain voids suitable for habitation by vermin.

The requirements according to ETAG 009, chapter 6.7.1.3 are met satisfactorily.

2.2.8.2 Resistance to normal use damage

Normal use impacts

Concrete walls (without consideration of the finishes), erected with shuttering system "WOLF THERMO MODULE" and designed according EN 1992-1-1 respectively in lack of availability of EN 1992-1-1 according national design rules, lead to the assumption that concrete infill insures an adequate resistance of the complete wall under normal used impact loads.

The requirements according to ETAG 009, chapter 6.7.2.1 are met satisfactorily.

Incorporation of ducts

The instructions in the installation guide of the ETA holder are appropriate to produce horizontal perforations through the walls, which are necessary for passing through ducts, see also clause 4.2.4.

The requirements according to ETAG 009, chapter 6.7.2.2 are met satisfactorily.

Fixings of objects

Fixing of objects in the shuttering leaves is not possible. The part of fixings which is relevant for the mechanical resistance shall be in the concrete.

3 Evaluation and attestation of conformity and CE marking

3.1 System of attestation of conformity

According to the Decision 98/279/EC of 05 December 1997¹⁰ amended by the decision 2001/596/EC of the European Commission¹¹ system 2+ of the attestation of conformity applies.

This system of attestation of conformity is defined as follows:

System 2+: Declaration of conformity of the product by the manufacturer on the basis of:

(a) Tasks for the manufacturer:

- (1) initial type-testing of the product;
- (2) factory production control;
- (3) testing of samples taken at the factory in accordance with a prescribed test plan.

(b) Tasks for the approved body:

- (4) certification of factory production control on the basis of:
 - initial inspection of factory and of factory production control;
 - continuous surveillance, assessment and approval of factory production control.

Note: Approved bodies are also referred to as "notified bodies".

¹⁰

Official Journal of the European Communities L /127 of 24 April 1998

¹¹

Official Journal of the European Communities L /209 of 8 January 2001

3.2 Responsibilities

3.2.1 Tasks for the manufacturer

3.2.1.1 Factory production control

The manufacturer shall exercise permanent internal control of production. All the information, requirements and provisions adopted by the manufacturer shall be documented in a systematic manner in the form of written policies and procedures, including records of results performed. This production control system shall insure that the product is in conformity with this European technical approval.

The manufacturer may only use raw materials stated in the technical documentation of this European technical approval.

The factory production control shall be in accordance with the control plan of 06.12.2011 which is part of the technical documentation of this European technical approval. The control plan is laid down in the context of the factory production control system operated by the manufacturer and deposited with Deutsches Institut für Bautechnik.¹²

The results of factory production control shall be recorded and evaluated in accordance with the provisions of the control plan.

3.2.1.2 Other tasks for the manufacturer

The manufacturer shall, on the basis of a contract, involve a body which is approved for the tasks referred to in section 3.1 in the field of non-load bearing shuttering systems in order to undertake the actions laid down in section 3.2.2. For this purpose, the control plan referred to in sections 3.2.1.1 and 3.2.2 shall be handed over by the manufacturer to the approved body involved.

The manufacturer shall make a declaration of conformity, stating that the construction product is in conformity with the provisions of this European technical approval.

3.2.2 Tasks for the approved bodies

The approved body shall perform the

- initial inspection of factory and of factory production control,
- continuous surveillance, assessment and approval of factory production control,

in accordance with the provisions laid down in the control plan.

The frequency of the inspections by the approved bodies shall be performed in accordance with section II of control plan.

The approved body shall retain the essential points of its actions referred to above and state the results obtained and conclusions drawn in a written report.

The approved certification body involved by the manufacturer shall issue an EC certificate of conformity of the factory production control stating the conformity with the provisions of this European technical approval.

In cases where the provisions of the European technical approval and its control plan are no longer fulfilled the certification body shall withdraw the certificate of conformity and inform Deutsches Institut für Bautechnik without delay.

¹² The control plan is a confidential part of the European technical approval and only handed over to the approved bodies involved in the procedure of attestation of conformity. See section 3.2.2.

3.3 CE marking

The CE marking shall always be affixed on packing and on the accompanying commercial documents. The letters "CE" shall be followed by the identification number of the approved certification body, and be accompanied by the following additional information:

- the name and address of the producer (legal entity responsible for the manufacture),
- the last two digits of the year in which the CE marking was affixed,
- the number of the EC certificate for the factory production control,
- the number of the European technical approval ETA-11/0402,
- the number of the guideline ETAG 009 for European technical approval,
- Reaction to fire: Class E according to EN 13501-1 (see clause 2.2.3.1),
- Resistance to fire: Class according to EN 13501-2 in dependence of minimum thickness of the concrete core (see clause 2.2.3.2),
- Protection against noise "no performance determined",
- EPS - EN 13163 - T1 - L1 - W2 - S1 - P3 - BS150 - CS(10)150 - DS(N)5 - DLT(1)5,
- the declared value of thermal resistance R_D of the shuttering elements with concrete infill and without rendering (see clause 2.2.7.1).

4 Assumptions under which the fitness of the product for the intended use was favourably assessed

4.1 Manufacturing

The shuttering elements are manufactured in accordance with the provisions of the European technical approval using the automated manufacturing process as identified during the inspection of the plant by Deutsches Institut für Bautechnik (DIBt) and the approved body and laid down in the technical documentation.

The European technical approval is issued for the product on the basis of agreed data/information, deposited with the DIBt, which identifies the product that has been assessed and judged. Changes to the product or production process, which could result in this deposited data/information being incorrect, should be notified to DIBt before the changes are introduced. Deutsches Institut für Bautechnik will decide whether or not such changes affect the approval and consequently the validity of the CE marking on the basis of the approval and if so whether further assessment or alterations to the approval shall be necessary.

4.2 Installation

4.2.1 General

The manufacturer shall ensure that the requirements in accordance with sections 1, 2, and 4 are made known to those involved in planning and execution. The installation guide is deposited with Deutsches Institut für Bautechnik (DIBt) and shall be present at every construction site. If the manufacturer's instructions contain provisions which differ from those stated here, the specifications of the ETA shall apply.

After installation of the shuttering elements (see clause 4.2.2) the site-mixed or ready mixed concrete is brought in and compacted (see clause 4.2.3).

In end use conditions concrete walls of a continuous type¹³ of plain or reinforced concrete will be formed according to EN 1992-1-1 or according to corresponding national.

¹³ see ETAG 009 chapter 2.2

For structural design purposes the thickness of the wall and the weight per unit area G_w without rendering is shown in Annex 10.

In end use conditions the EPS-shuttering leaves are the main part of the thermal insulation of the walls.

4.2.2 Installation of the shuttering elements

The shuttering elements are put together on site in layers without mortar or adhesive. To receive stable floor high formworks the vertical joints between two elements of one layer have to be shifted of at least 12.5 cm to the vertical joints of the previous and next layer (see Annexes 7 and 8). It is important to ensure that the PP-spacers are aligned one above the other.

The PP-spacers are either assembled on site (concrete core thickness 125.0 mm, 187.5 mm and 250.0 mm) or foamed (factory-made) into the inner and outer EPS-shuttering leaves (concrete core thickness 140.0 mm).

First of all two layers of the entire floor plan shall be interlocked according to the installation guide of the ETA holder.

Afterwards leveling to the subsoil is performed (foundation, bottom plate, and slabs). Voids between the shuttering leaves and the uneven subsoil shall be sealed with PU foam before concreting.

The PP-spacer shall be stacked (one upon the other) for avoiding segregation of concrete, see Annexes 7 and 8.

Subsequently, according to the installation guide of the ETA holder, the walls shall be interlocked to floor height, leveled and fastened to pull-push props (scaffolding supports), see Annex 9.

The pull-push props shall be arranged at a distance of 1.00 m to maximum 1.50 m, to be connected over the entire wall height with the shuttering elements and to be fastened to the floor.

The necessary reinforcement according to the structural analysis shall also be installed in an appropriate way.

Corner shuttering elements and T shuttering elements shall be formed according to Annex 2.

The values of thermal resistance respectively thermal conductivity shall be laid down according to the relevant national technical regulation.

Further information is given in the installation manual.

4.2.3 Concreting

For the production of normal concrete with a minimum compressive strength class C20/25 EN 206-1 shall apply. The consistency of concrete on compacting by shaking shall be within the lower consistency range F3 and on compacting by poking within the upper consistency range F3. The maximum aggregate size shall be at least 4 mm and shall not exceed 16 mm. The concrete shall have rapid or middle strength development according to EN 206-1, Table 12.

Placing the concrete shall be performed only by persons who were instructed in the functions and in the proper handling of the shuttering system.

Placing the concrete shall be performed in layers of 0.75 m at a maximum vertical concreting rate of 1.0 m/h.

If equivalent national rules are not available the following instructions shall be considered:

Horizontal day joints shall be arranged preferably at the height of the floor. If day joints can not be avoided within the height between the floors, vertical composite reinforcement bars shall be installed. The composite reinforcement shall comply the following requirements:

- Two adjacent composite reinforcement bars shall not be situated in the same plane parallel to the surface of the wall.
- The distance between two composite reinforcement bars in the direction of the wall shall be at least 10 cm and not larger than 50 cm.
- The total section area of the composite reinforcement bars shall not be less than 1/2000 of the section area of the concrete.
- Anchorage length of the composite reinforcement bars on both sides of the day joint shall at least be 20 cm.

Before the further placing of concrete, cement laitance and detached / loose concrete shall be removed and the day joints shall be sufficiently pre-wetted. At the time of concreting the surface of the older concrete shall be slightly moist, so that the cement paste of the newly brought in concrete can bond well with the older concrete.

If no day joint is planned, placing of the concrete in layers may only be interrupted until the concrete layer brought in last is not solidified yet, so that a good and even bond is still possible between the two concrete layers. When using suitable internal vibrators care shall be taken that the vibrating cylinder can still penetrate the already compacted lower concrete layer.

The concrete may fall freely only up to a maximum height of 2.0 m, beyond that the concrete shall be placed by discharge pipes or concreting tubes with a diameter of 100 mm at the most and shall be led directly to the place of installation.

Cones from pouring shall be avoided by short distances of the places of fill in.

Planning shall allow for sufficient spaces in the reinforcement for discharge pipes or concreting tubes.

After concreting, the walls may not deviate from the plumb line more than 5 mm per running meter wall height, respectively for a wall height greater than 3.0 m not more than 16 mm.

The floor slab may only be placed on walls made of shuttering elements if a sufficient strength of the infill concrete has been reached.

4.2.4 Ducts crossing and situated inside the wall

Horizontally passing ducts shall be installed according to the installation guide of the ETA holder and shall be taken into account when designing the wall.

Horizontal ducts situated inside the wall cores shall be avoided. If absolutely necessary, these shall be taken into account when designing the wall.

Also, vertical ducts in the concrete core shall be considered, if their diameter exceeds 1/6 of the thickness of the concrete core and the distance of the pipes is less than 2.0 m.

4.2.5 Reworking and finishes

Walls of the type "WOLF THERMO MODULE" shall be protected by finishes (e. g. rendering, plasters, cladding, panelling, coatings). Finishes are not part of the kit and therefore not considered in this ETA. Preferably, for external surfaces the used rendering systems should meet the requirement of ETAG 004. The cladding respectively panelling or their substructures shall be anchored in the concrete core. The execution of the rendering shall be performed according to applicable national rules.

The protection by finishes should be implemented preferably within one month after erecting the structural structure, because of the detrimental influence of weather and UV-radiation on the surface of the EPS-leaves.

4.2.6 Fixing of objects

Fixing of objects in the shuttering leaves is not possible. The part of fixings which is relevant for the mechanical resistance shall be in the concrete. The influence of the fixing to the reduction of the thermal resistance has to be considered according to EN ISO 6946.

5 Indications to the manufacturer

5.1 Packaging, transport and storage

The shuttering elements have to be protected against damage, soiling and intensive action of water during transport and storage. If necessary the elements have to be covered.

5.2 Use, maintenance, repair

Regular checks should be carried out on render finishes to ensure that any damage is detected and repaired as soon as possible.

The recommendations on use, maintenance and repair in ETAG 009, section 7.5 shall be considered.

The shuttering elements have to be protected against high temperature, overheating and intensive exposure to weather and UV-radiation. If necessary, the elements have to be covered.

Georg Feistel
Head of Department

beglaubigt:
Schwab

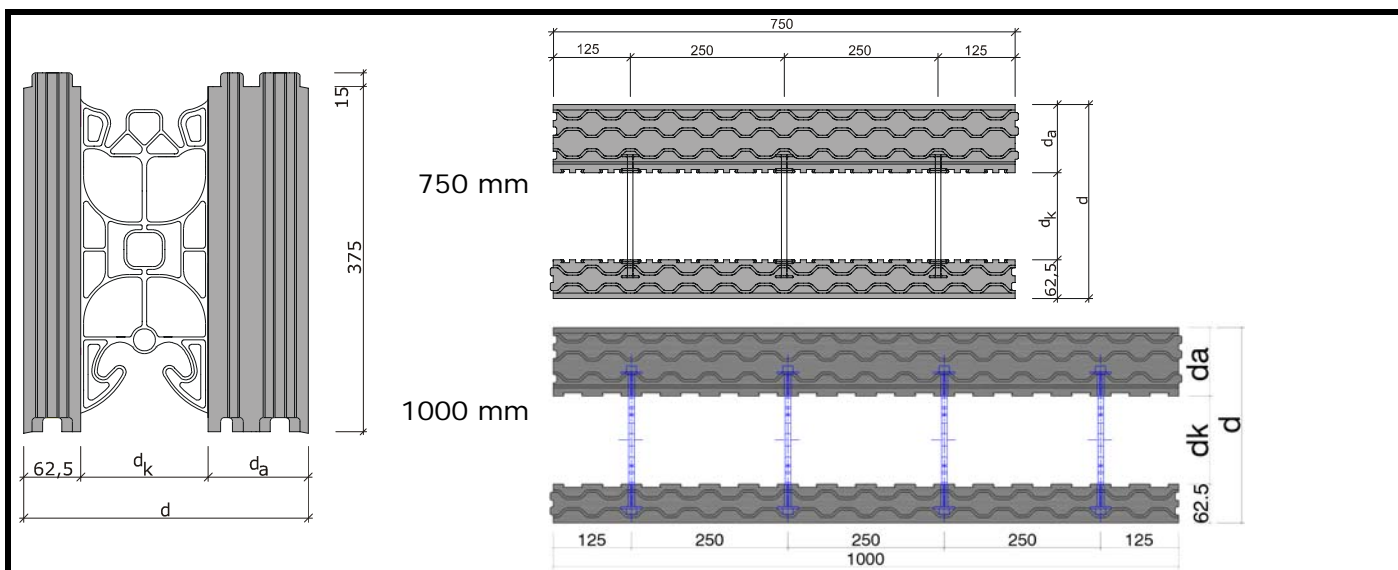

The thickness of the inner shuttering leaves is always 62.5 mm.

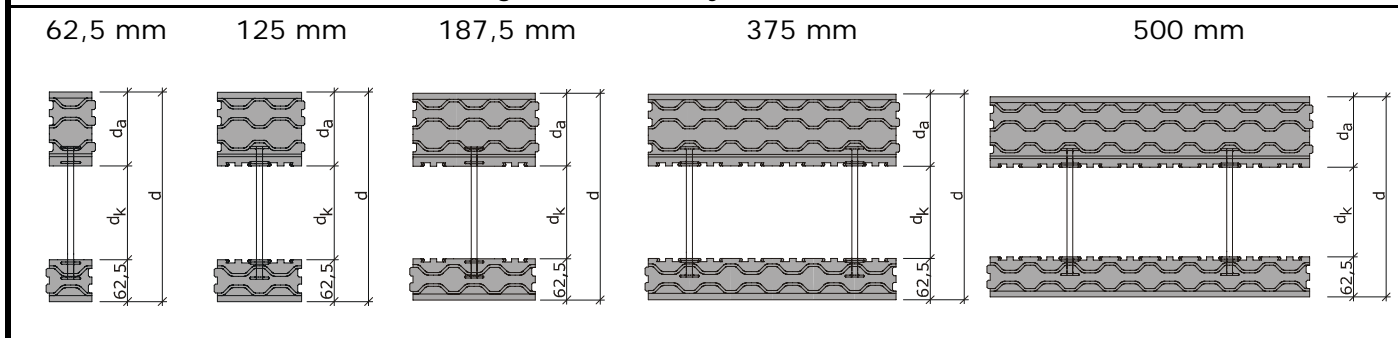

Type	Concrete core d_k	EPS-leaves (outer) d_a	d
G 62,5-312	140.0	110.0	312.5
G 125-312	140.0	110.0	312.5
G 187,5-312	140.0	110.0	312.5
G 375-312	140.0	110.0	312.5
G 500-312	140.0	110.0	312.5
G 750-312	140.0	110.0	312.5
G 1000-312	140.0	110.0	312.5
G 62,5-437	140.0	235.0	437.5
G 125-437	140.0	235.0	437.5
G 187,5-437	140.0	235.0	437.5
G 375-437	140.0	235.0	437.5
G 500-437	140.0	235.0	437.5
G 750-437	140.0	235.0	437.5
G 1000-437	140.0	235.0	437.5
G 62,5-250	125.0	62.5	250.0
G 125-250	125.0	62.5	250.0
G 187,5-250	125.0	62.5	250.0
G 375-250	125.0	62.5	250.0
G 500-250	125.0	62.5	250.0
G 750-250	125.0	62.5	250.0
G 1000-250	125.0	62.5	250.0
Type	Concrete core d_k	EPS-leaves (outer) d_a	d
G 62,5-312/187	187.5	62.5	312.5
G 125-312/187	187.5	62.5	312.5
G 187,5-312/187	187.5	62.5	312.5
G 375-312/187	187.5	62.5	312.5
G 500-312/187	187.5	62.5	312.5
G 750-312/187	187.5	62.5	312.5
G 1000-312/187	187.5	62.5	312.5
G 62,5-375	250.0	62.5	375.0
G 125-375	250.0	62.5	375.0
G 187,5-375	250.0	62.5	375.0
G 375-375	250.0	62.5	375.0
G 500-375	250.0	62.5	375.0
G 750-375	250.0	62.5	375.0
G 1000-375	250.0	62.5	375.0
G 1000-375	140.0	172.5	375.0
G 1000-500	140.0	297.5	500.0

Note: The bond of the shuttering elements has to be executed with a distance of the PP-spacers of at least 12.5 cm.

All dimensions in [mm]

WOLF THERMO MODULE	Annex 1
Standard shuttering elements	

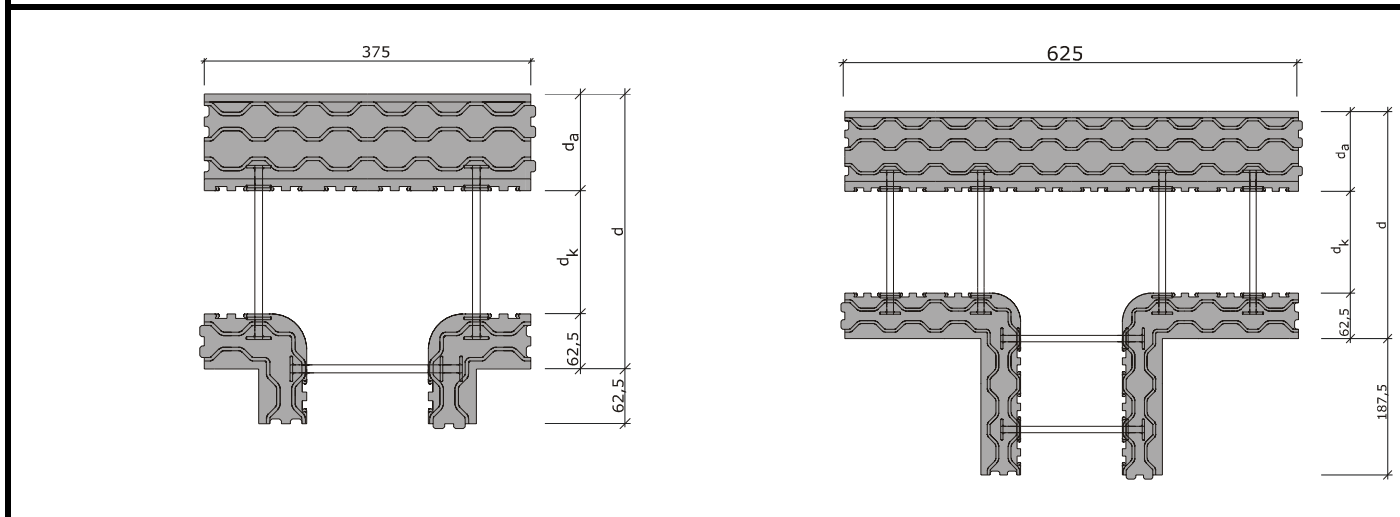
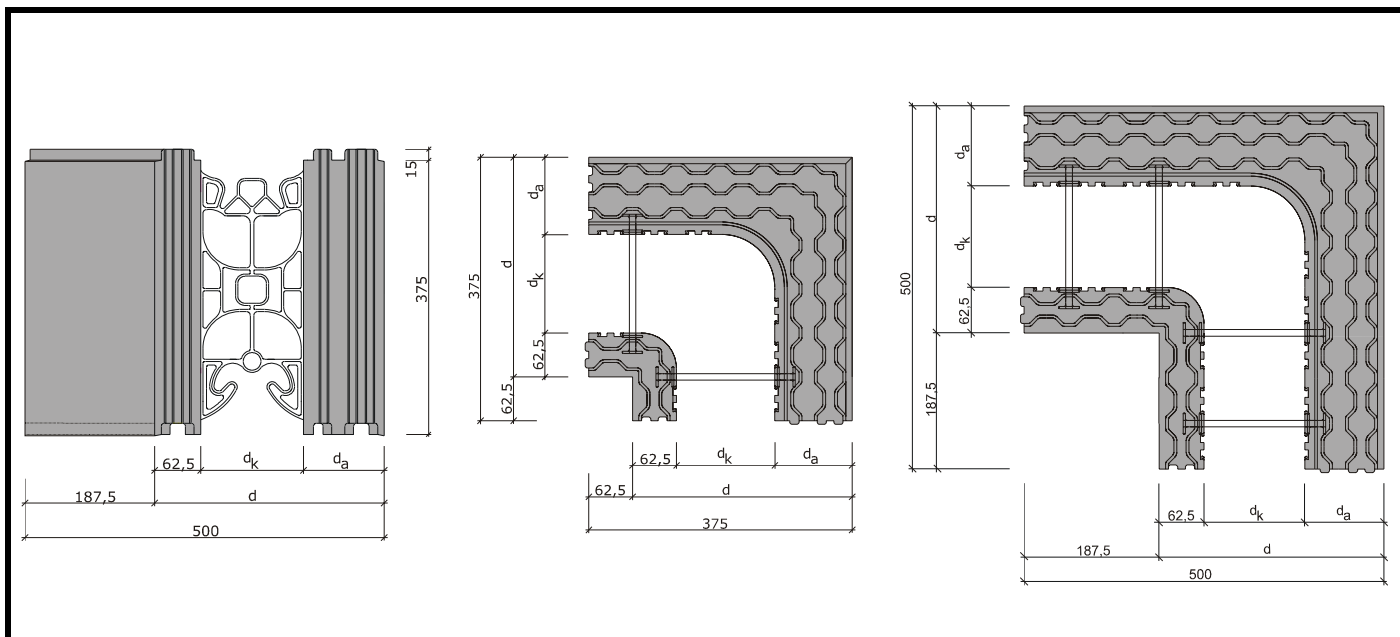

d , d_a and d_k see Annex 1

	Type	Concrete core d_k
	E 125	125.0
	E 140	140.0
	E 187,5	187.5
	E 250	250.0

All dimensions in [mm]

WOLF THERMO MODULE	Annex 2
Corner shuttering elements and T shuttering elements	

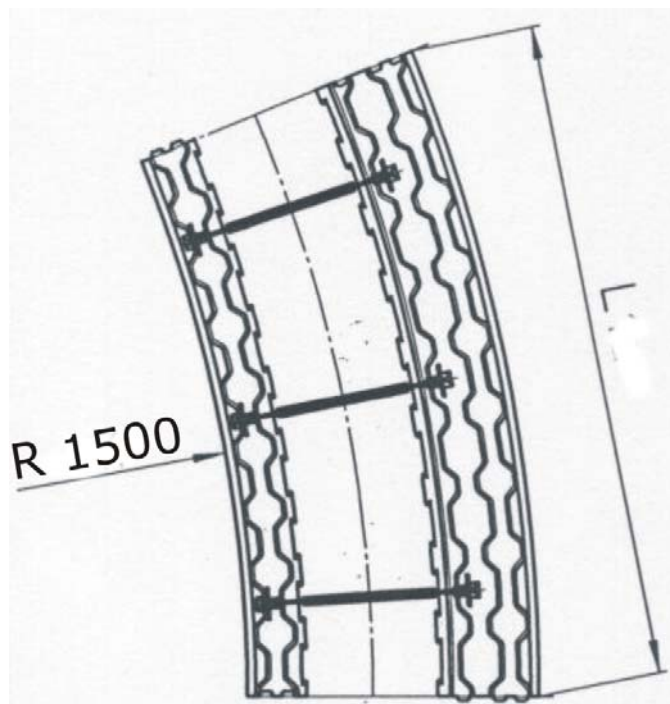
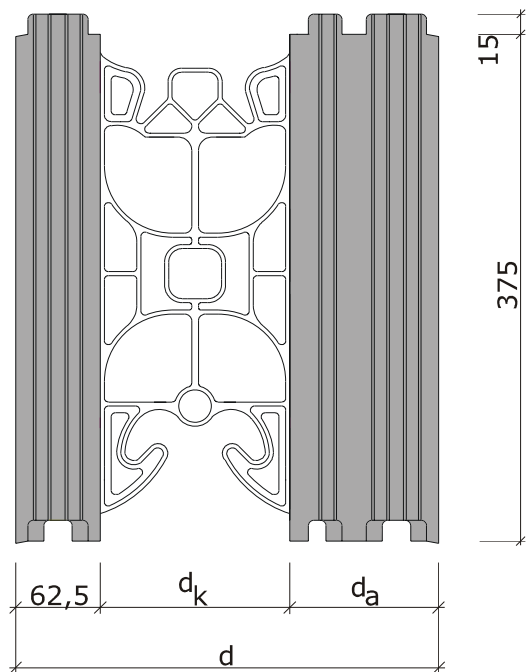

Type	L	d	Concrete core d_k	EPS-leaves (outer) d_a
RA 1500/312 A	707.2	312.5	140.0	110.0
RA 1500/312 B	238.5	312.5	140.0	110.0
RA 1500/437 A	707.2	437.5	140.0	235.0
RA 1500/437 B	238.5	437.5	140.0	235.0

All dimensions in [mm]

WOLF THERMO MODULE

Curved shuttering elements, R = 1500 mm

Annex 3

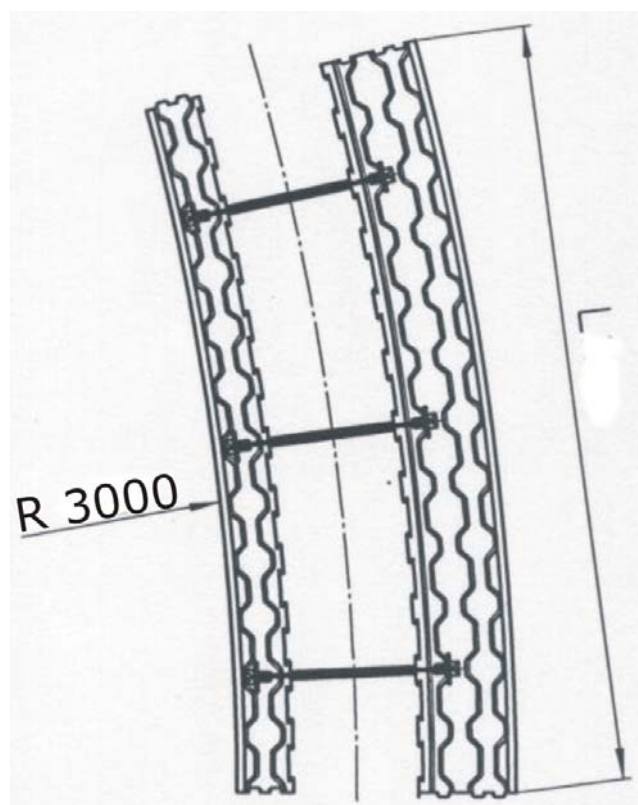
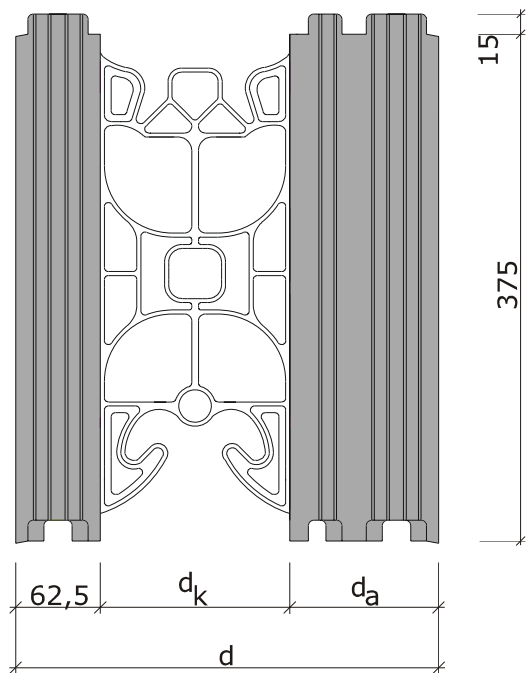

Type	L	d	Concrete core d_k	EPS-leaves (outer) d_a
RA 3000/312 A	864.7	312.5	140.0	110.0
RA 3000/312 B	288.9	312.5	140.0	110.0
RA 3000/437 A	864.7	437.5	140.0	235.0
RA 3000/437 B	288.9	437.5	140.0	235.0

All dimensions in [mm]

WOLF THERMO MODULE

Curved shuttering elements, R = 3000 mm

Annex 4

Lintel shuttering element

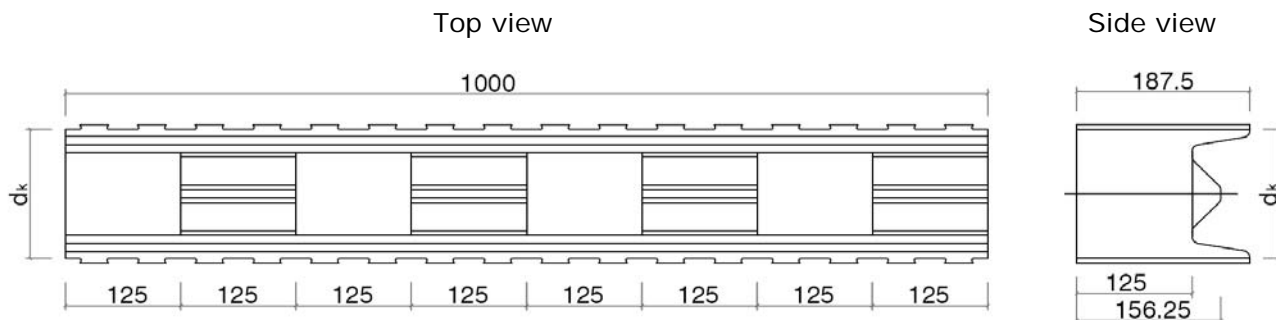

End stop

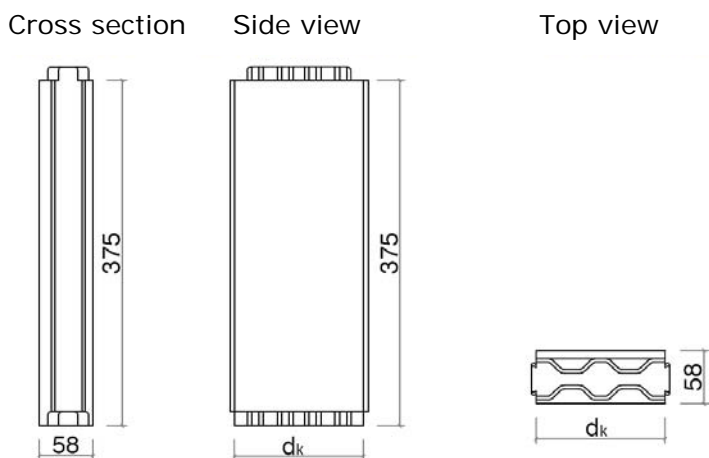

All dimensions in [mm]

WOLF THERMO MODULE

Accessory parts: Lintel shuttering elements and End stops

Annex 5

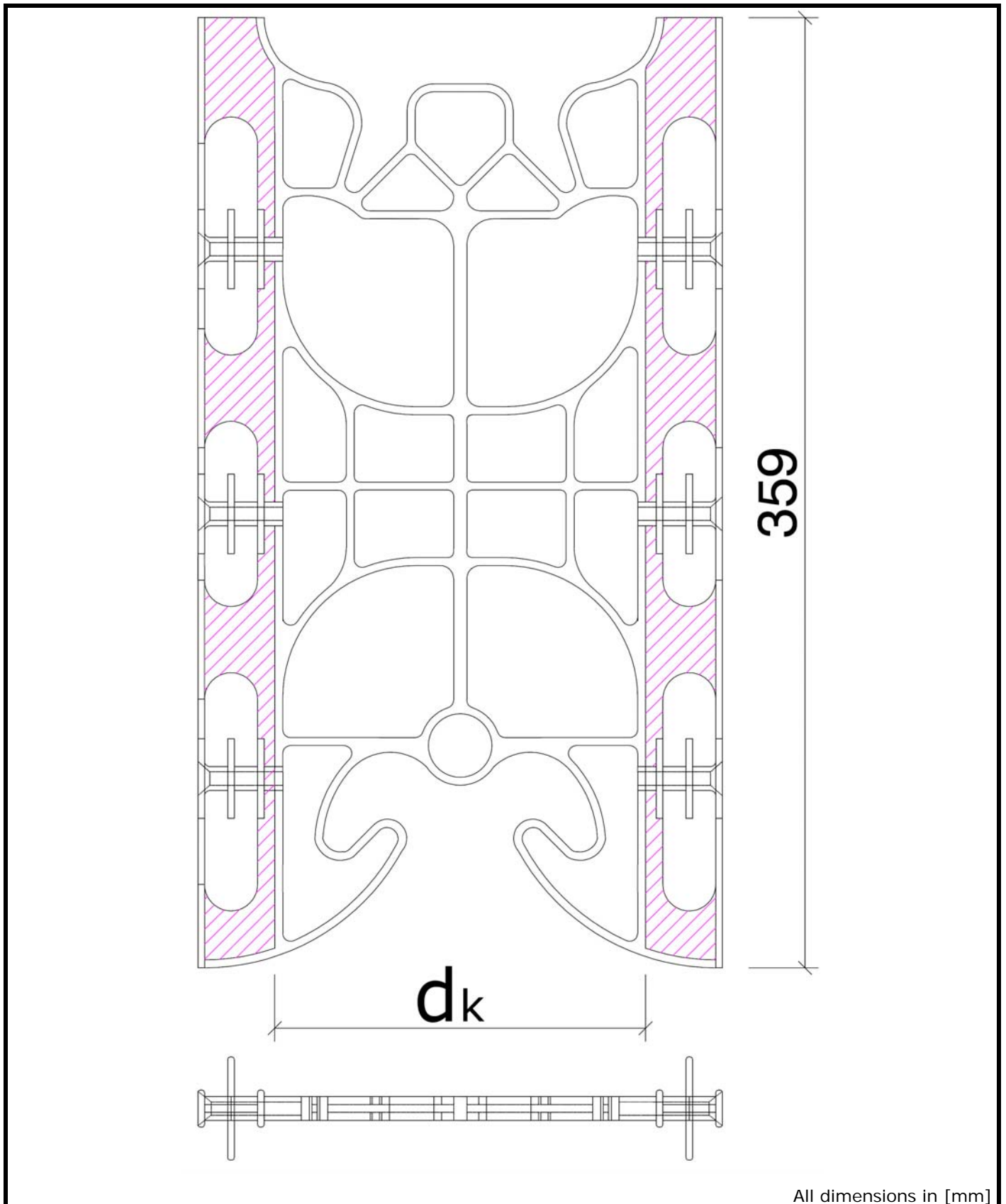

WOLF THERMO MODULE

Spacers of polypropylene (PP-spacers)

Annex 6

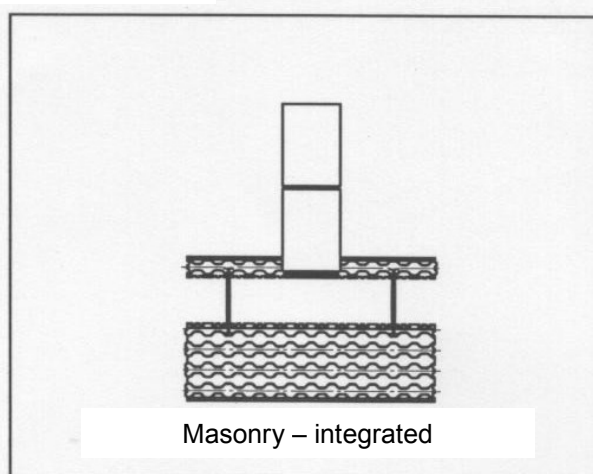
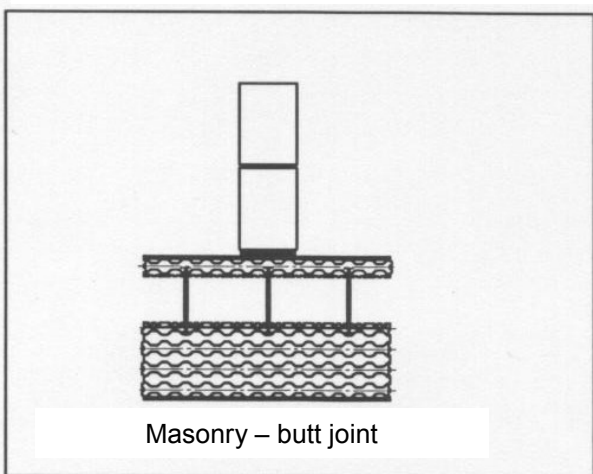
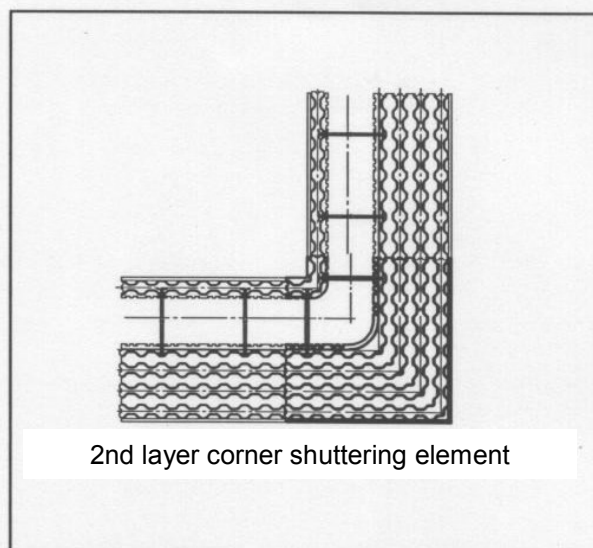
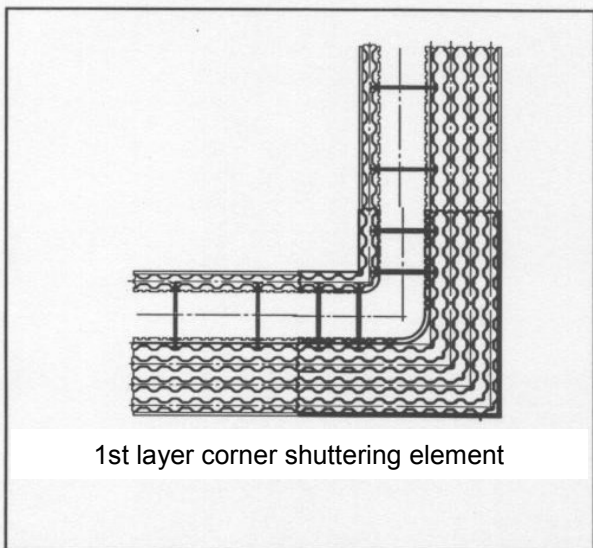
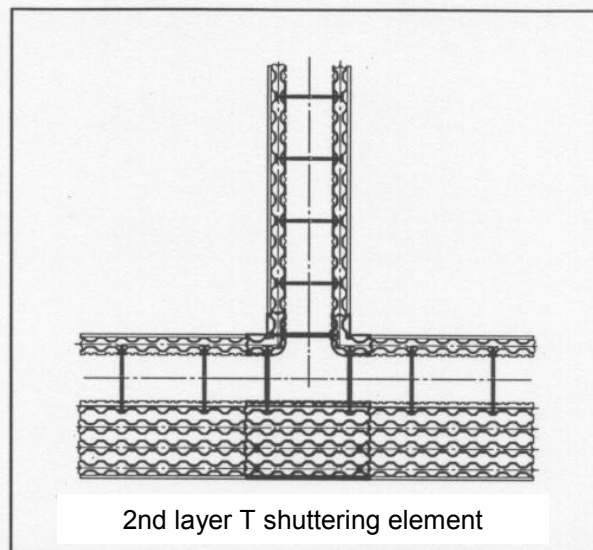
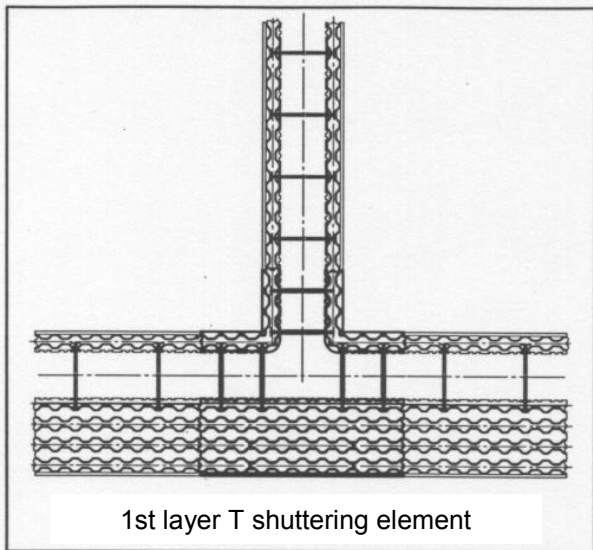

WOLF THERMO MODULE

Structure of layers: T shuttering elements and Corner shuttering elements
Connection: Masonry – Shuttering elements

Annex 7

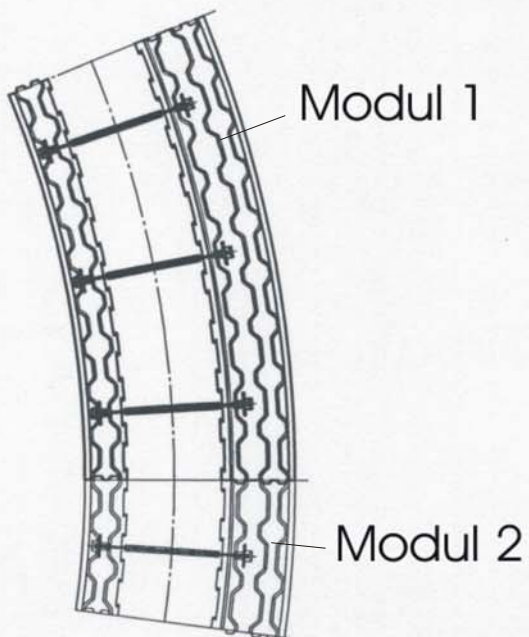

1st layer curved shuttering element R = 1500 mm

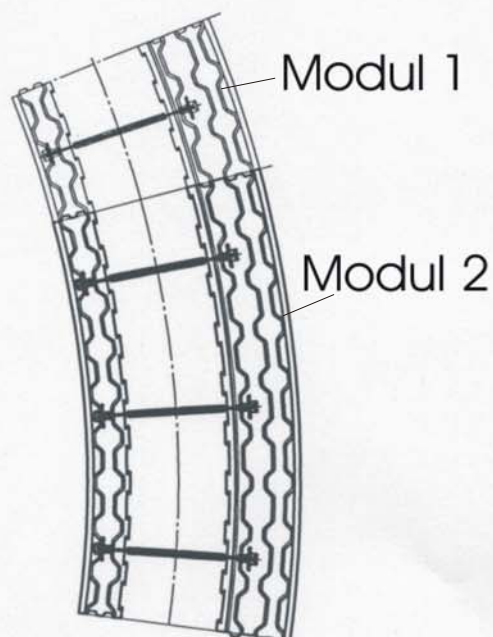

2nd layer curved shuttering element R = 1500 mm

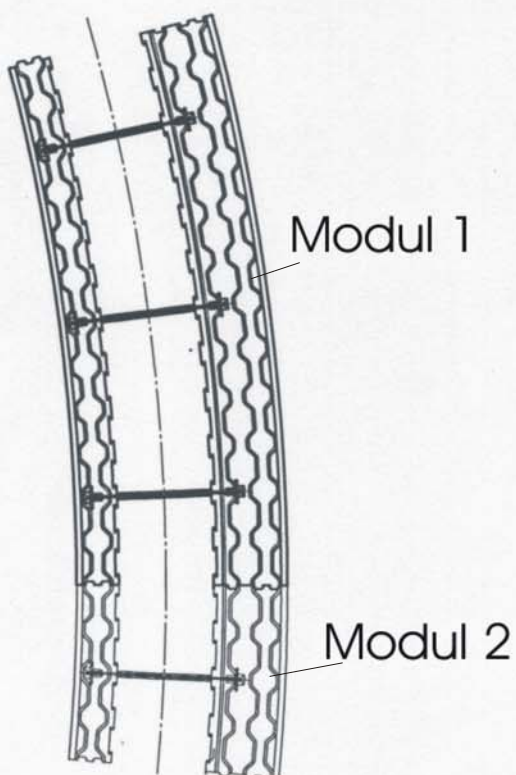

1st layer curved shuttering element R = 3000 mm

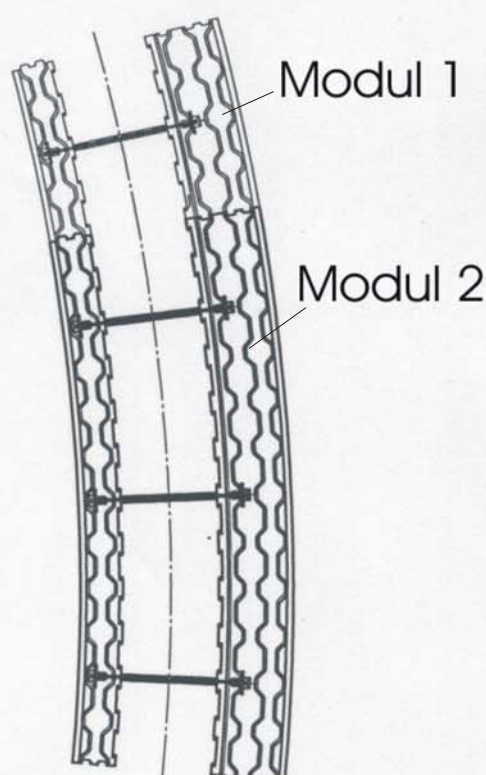

2nd layer curved shuttering element R = 3000 mm

WOLF THERMO MODULE

Structure of layers: Curved shuttering elements

Annex 8

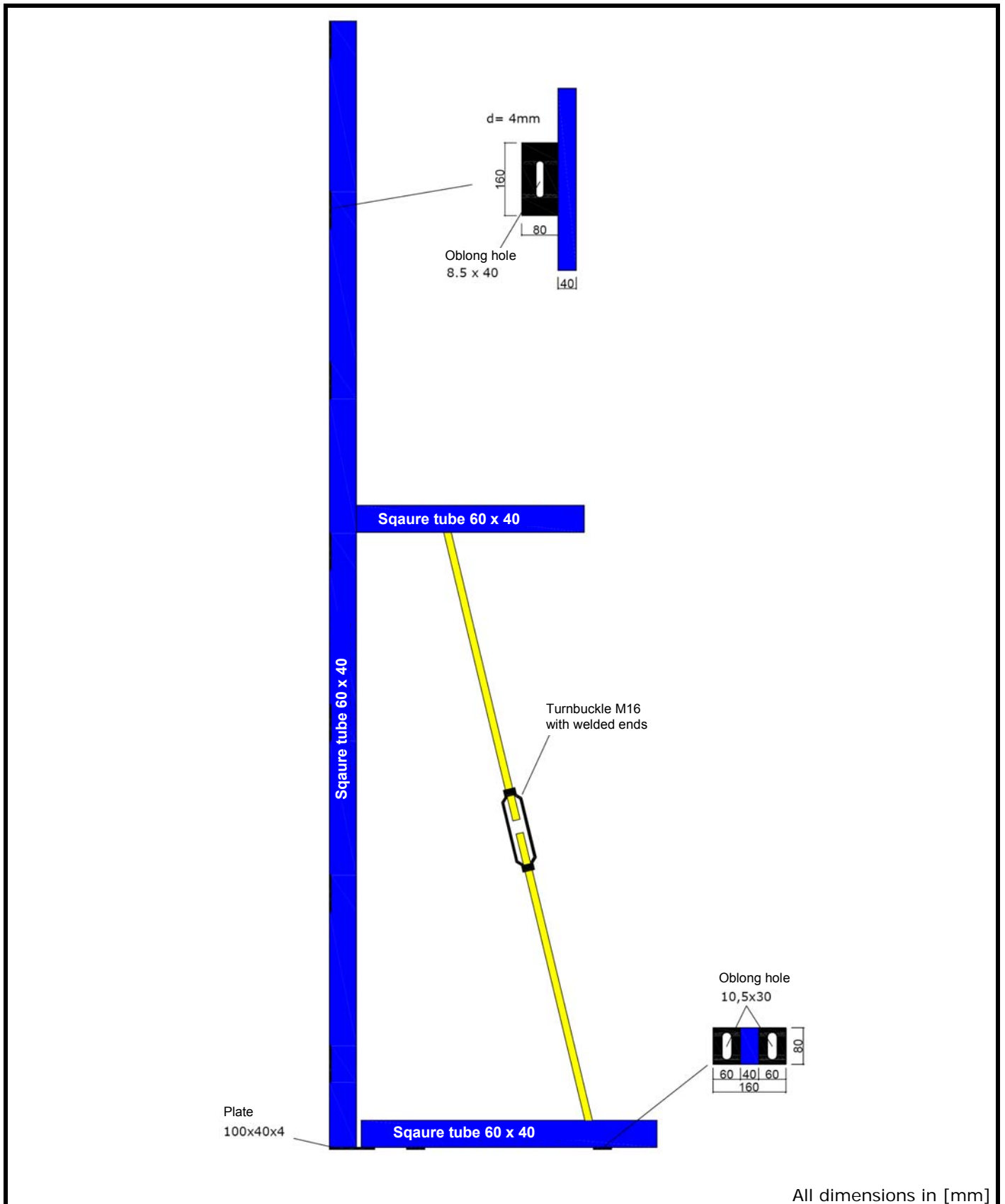

WOLF THERMO MODULE

Pull-push props

Annex 9

Type	see Annex	All-over wall thickness	Concrete core	Volume of concrete core per m ² wall area	Calculation weight of the		
		d			Shuttering element	PP-spacer	Wall (without plaster)
	N ^o	mm	d _k	V _k	G _S	G _{PP}	G _W
G 62,5-312	1	312.5	140.0	0.143	0.04	0.160	3.54
G 125-312	1	312.5	140.0	0.143	0.04	0.160	3.54
G 187,5-312	1	312.5	140.0	0.143	0.04	0.160	3.54
G 375-312	1	312.5	140.0	0.143	0.04	0.160	3.54
G 500-312	1	312.5	140.0	0.143	0.04	0.160	3.54
G 750-312	1	312.5	140.0	0.143	0.04	0.160	3.54
G 1000-312	1	312.5	140.0	0.143	0.04	0.160	3.54
G 62,5-437	1	437.5	140.0	0.143	0.07	0.160	3.57
G 125-437	1	437.5	140.0	0.143	0.07	0.160	3.57
G 187,5-437	1	437.5	140.0	0.143	0.07	0.160	3.57
G 375-437	1	437.5	140.0	0.143	0.07	0.160	3.57
G 500-437	1	437.5	140.0	0.143	0.07	0.160	3.57
G 750-437	1	437.5	140.0	0.143	0.07	0.160	3.57
G 1000-437	1	437.5	140.0	0.143	0.07	0.160	3.57
G 62,5-250	1	250.0	125.0	0.128	0.03	0.145	3.16
G 125-250	1	250.0	125.0	0.128	0.03	0.145	3.16
G 187,5-250	1	250.0	125.0	0.128	0.03	0.145	3.16
G 375-250	1	250.0	125.0	0.128	0.03	0.145	3.16
G 500-250	1	250.0	125.0	0.128	0.03	0.145	3.16
G 750-250	1	250.0	125.0	0.128	0.03	0.145	3.16
G 1000-250	1	250.0	125.0	0.128	0.03	0.145	3.16
G 62,5-312/187	1	312.5	187.5	0.191	0.03	0.185	4.72
G 125-312/187	1	312.5	187.5	0.191	0.03	0.185	4.72
G 187,5-312/187	1	312.5	187.5	0.191	0.03	0.185	4.72
G 375-312/187	1	312.5	187.5	0.191	0.03	0.185	4.72
G 500-312/187	1	312.5	187.5	0.191	0.03	0.185	4.72
G 750-312/187	1	312.5	187.5	0.191	0.03	0.185	4.72
G 1000-312/187	1	312.5	187.5	0.191	0.03	0.185	4.72
G 62,5-375	1	375.0	250.0	0.253	0.03	0.240	6.28
G 125-375	1	375.0	250.0	0.253	0.03	0.240	6.28
G 187,5-375	1	375.0	250.0	0.253	0.03	0.240	6.28
G 375-375	1	375.0	250.0	0.253	0.03	0.240	6.28
G 500-375	1	375.0	250.0	0.253	0.03	0.240	6.28
G 750-375	1	375.0	250.0	0.253	0.03	0.240	6.28
G 1000-375	1	375.0	250.0	0.253	0.03	0.240	6.28
G 1000-375	1	375.0	140.0	0.143	0.05	0.160	3.55
G 1000-500	1	500.0	140.0	0.143	0.08	0.160	3.58
WOLF THERMO MODULE							Annex 10
Dimensions, volumes and calculation weight of the shuttering elements							

standards and guidelines		issue	title
EN	206-1	2000	Concrete – Part 1: Specification, performance, production and conformity
EN	1992-1-1	2004	Eurocode 2: Design of concrete structures – Part 1-1: General rules and rules for buildings
EN	12090	1997	Thermal insulating products for building applications – Determination of shear behaviour
EN	13163	2001	Thermal insulation products for buildings – Factory made products of expanded polystyrene (EPS) – Specification
EN	13501-1	2007	Fire classification of construction products and building elements – Part 1: Classification using test data from reaction to fire tests
EN	13501-2	2003	Fire classification of construction products and building elements – Part 2: Classification using data from fire resistance tests, excluding ventilation services
EN ISO	6946	2007	Building components and building elements – Thermal resistance and thermal transmittance – Calculation method
EN ISO	10456	2007	Building materials and products – Hygrothermal properties – Tabulated design values and procedures for determining declared and design thermal values
EN ISO	13788	2001	Hygrothermal performance of building components and building elements – Internal surface temperature to avoid critical surface humidity and interstitial condensation – Calculation methods
ETAG	004	2000-03	Guideline for European technical approval of "External thermal insulation composite systems with rendering"
ETAG	009	2002-06	Guideline for European technical approval of "Non load bearing permanent shuttering kits/systems based on hollow blocks or panels of insulating materials and sometimes concrete"
WOLF THERMO MODULE			Annex 11
List of standards and guidelines			