



European Technical Approval ETA-11/0409

English translation prepared by DIBt - Original version in German language

Handelsbezeichnung <i>Trade name</i>	Eternit-Tergo-Hinterschnittanker für Eternit-Fassadentafeln <i>Eternit-Tergo-undercut anchor for Eternit- facade panels</i>
Zulassungsinhaber <i>Holder of approval</i>	Eternit Aktiengesellschaft Im Breitspiel 20 69126 Heidelberg DEUTSCHLAND
Zulassungsgegenstand und Verwendungszweck <i>Generic type and use of construction product</i>	Spezialanker zur rückseitigen Befestigung von Fassadentafeln aus Faserzement nach EN 12467 <i>special anchor for the rear fixing of facade panels made of fibre-cement according to EN 12467</i>
Geltungsdauer: <i>Validity:</i>	vom <i>from</i> bis <i>bis</i> to
Herstellwerk <i>Manufacturing plant</i>	Eternit Werk

Diese Zulassung umfasst
This Approval contains

17 Seiten einschließlich 8 Anhänge
17 pages including 8 annexes

I LEGAL BASES AND GENERAL CONDITIONS

- 1 This European technical approval is issued by Deutsches Institut für Bautechnik in accordance with:
 - Council Directive 89/106/EEC of 21 December 1988 on the approximation of laws, regulations and administrative provisions of Member States relating to construction products¹, modified by Council Directive 93/68/EEC² and Regulation (EC) N° 1882/2003 of the European Parliament and of the Council³;
 - Gesetz über das Inverkehrbringen von und den freien Warenverkehr mit Bauprodukten zur Umsetzung der Richtlinie 89/106/EWG des Rates vom 21. Dezember 1988 zur Angleichung der Rechts- und Verwaltungsvorschriften der Mitgliedstaaten über Bauprodukte und anderer Rechtsakte der Europäischen Gemeinschaften (Bauproduktengesetz - BauPG) vom 28. April 1998⁴, as amended by law of 31 October 2006⁵;
 - Common Procedural Rules for Requesting, Preparing and the Granting of European technical approvals set out in the Annex to Commission Decision 94/23/EC⁶.
- 2 Deutsches Institut für Bautechnik is authorized to check whether the provisions of this European technical approval are met. Checking may take place in the manufacturing plant. Nevertheless, the responsibility for the conformity of the products to the European technical approval and for their fitness for the intended use remains with the holder of the European technical approval.
- 3 This European technical approval is not to be transferred to manufacturers or agents of manufacturers other than those indicated on page 1, or manufacturing plants other than those indicated on page 1 of this European technical approval.
- 4 This European technical approval may be withdrawn by Deutsches Institut für Bautechnik, in particular pursuant to information by the Commission according to Article 5(1) of Council Directive 89/106/EEC.
- 5 Reproduction of this European technical approval including transmission by electronic means shall be in full. However, partial reproduction can be made with the written consent of Deutsches Institut für Bautechnik. In this case partial reproduction has to be designated as such. Texts and drawings of advertising brochures shall not contradict or misuse the European technical approval.
- 6 The European technical approval is issued by the approval body in its official language. This version corresponds fully to the version circulated within EOTA. Translations into other languages have to be designated as such.

¹ Official Journal of the European Communities L 40, 11 February 1989, p. 12
² Official Journal of the European Communities L 220, 30 August 1993, p. 1
³ Official Journal of the European Union L 284, 31 October 2003, p. 25
⁴ *Bundesgesetzblatt Teil I 1998*, p. 812
⁵ *Bundesgesetzblatt Teil I 2006*, p. 2407, 2416
⁶ Official Journal of the European Communities L 17, 20 January 1994, p. 34

II SPECIFIC CONDITIONS OF THE EUROPEAN TECHNICAL APPROVAL

1 Definition of the product and intended use

1.1 Definition of the product

The Eternit-Tergo-undercut anchor for Eternit-façade panels is a special anchor made of a crosswise slotted anchor sleeve with internal thread and a rectangular sheet metal at the top, a related screw and a washer. The anchor sleeve, screw and washer are made of stainless steel.

The anchor is put into an undercut drill hole, locked against rotation by setting to the fixing member (single agraffe, double agraffe, long-span agraffe and panel load-bearing profile) and placed form-fitted and anchored way-controlled by pulling the screw.

Annex 1 shows the anchor at built-in state.

1.2 Intended use

The Eternit-Tergo-undercut anchor may be used for the rear fixing of Eternit-façade panels. The façade panels shall be classified according to EN 12467 "Fibre-cement flat sheets" and shall correspond to the specifications of annex 8.

The façade panels with rear fixing by the anchor may be used for front curtain walls. Each façade panel shall be fixed technically strain-free with at least four anchors in a rectangular arrangement via single agraffes, double agraffes, long-span agraffes or panel load-bearing profiles according to the installation instructions on a capable substructure.

The anchor may be used in structures subject to dry internal conditions and also in structures subject to external atmospheric exposure (including industrial and marine environment), if no particular aggressive conditions exist. Such particular aggressive conditions are e.g. permanent, alternating immersion in seawater or the splash zone of seawater, chloride atmosphere of indoor swimming pools or atmosphere with extreme chemical pollution (e.g. in desulphurisation plants or road tunnels where de-icing materials are used).

The provisions made in this European Technical Approval are based on an assumed working life of the anchor of 50 years. The indications given on the working life cannot be interpreted as a guarantee given by the producer, but are to be regarded only as a means for choosing the right products in relation to the expected economically reasonable working life of the works.

2 Characteristics of the product and method of verification

2.1 Characteristics of the product

The anchor corresponds to the drawings and specifications given in Annex 2. The characteristic material values, dimensions and tolerances of the anchor not indicated in Annex 2 shall correspond to the respective values laid down in the technical documentation⁷ of this European technical approval.

⁷ The technical documentation comprises all information necessary for the production, installation and maintenance of the anchor; these are in particular the design drawings and the installation instructions. The part to be treated confidentially is deposited with Deutsches Institut für Bautechnik and, as far as this is relevant to the tasks of the approved bodies involved in the procedure of attestation of conformity, shall only be handed over to the approved body.

The anchor is considered to satisfy the requirements for performance class A1 of the characteristic reaction to fire, in accordance with the provisions of EC decision 96/603/EC (as amended) without the need for testing on the basis of its listing in that decision.

In addition to the specific clauses relating to dangerous substances contained in this European Technical Approval, there may be other requirements applicable to the products falling within its scope (e.g. transposed European legislation and national laws, regulations and administrative provisions). In order to meet the provisions of the Construction Products Directive, these requirements need also to be complied with, when and where they apply.

The characteristic values for the design of the façade panels with rear fixing by the anchor are given in Annex 5.

Every anchor is marked with the identifying mark of the producer according to Annex 2.

2.2 Methods of verification

The assessment of fitness of the anchor for the intended use in relation to the requirement for safety in use in the sense of the essential requirement N°4 of Council Directive 89/106/EEC has been made based on the following tests:

- (1) Axial tension tests
- (2) Shear tests
- (3) Tests with combined tension and shear loading
- (4) Tests on structural members
- (5) Tests on functioning under repeated loads
- (6) Tests on functioning under sustained loads
- (7) Tests on functioning under freeze/thaw conditions (25 freeze/thaw cycles)
- (8) Tests on functioning after immersion in water
- (9) Tests on functioning under temperature

3 Evaluation and attestation of conformity and CE marking

3.1 System of attestation of conformity

According to the communication of the European Commission⁸ the system 2 (ii)-1 (referred to as System 2+) of attestation of conformity applies.

These systems of attestation of conformity are defined as follows:

System 2+: Declaration of conformity of the product by the manufacturer on the basis of:

- (a) Tasks for the manufacturer:
 - (1) initial type-testing of the product;
 - (2) factory production control;
 - (3) testing of samples taken at the factory in accordance with a prescribed test plan.
- (b) Tasks for the approved body:
 - (4) certification of factory production control on the basis of:
 - initial inspection of factory and of factory production control;
 - continuous surveillance, assessment and approval of factory production control.

⁸ Letter of the European Commission of 22/07/2002 to EOTA

3.2 Responsibilities

3.2.1 Tasks for the manufacturer

3.2.1.1 Factory production control

The manufacturer shall exercise permanent internal control of production. All the elements, requirements and provisions adopted by the manufacturer shall be documented in a systematic manner in the form of written policies and procedures, including records of results performed. This production control system shall insure that the product is in conformity with this European Technical Approval.

The manufacturer may only use initial materials and components stated in the technical documentation of this European Technical Approval.

The factory production control shall be in accordance with the control plan⁹ of 27th September 2011 which is part of the technical documentation of this European Technical Approval. The control plan is laid down in the context of the factory production control system operated by the manufacturer and deposited with Deutsches Institut für Bautechnik.

The results of factory production control shall be recorded and evaluated in accordance with the provisions of the control plan.

3.2.1.2 Other tasks for the manufacturer

The manufacturer shall, on the basis of a contract, involve a body which is approved for the tasks referred to in section 3.1 in the field of "anchors" in order to undertake the actions laid down in section 3.2.2. For this purpose, the control plan referred to in sections 3.2.1.1 and 3.2.2 shall be handed over by the manufacturer to the approved body involved.

The manufacturer shall make a declaration of conformity, stating that the construction product is in conformity with the provisions of this European Technical Approval.

3.2.2 Tasks of approved bodies

The approved body shall perform the following tasks in accordance with the provisions laid down in the control plan:

- initial inspection of factory and of factory production control,
- continuous surveillance, assessment and approval of factory production control.

The approved body shall retain the essential points of its actions referred to above and state the results obtained and conclusions drawn in a written report.

The approved certification body involved by the manufacturer shall issue an EC certificate of conformity of the factory production control stating the conformity with the provisions of this European Technical Approval.

In cases where the provisions of the European Technical Approval and its "control plan" are no longer fulfilled the certification body shall withdraw the certificate of conformity and inform Deutsches Institut für Bautechnik without delay.

⁹ The control plan is a confidential part of the European technical approval and only handed over to the approved body involved in the procedure of attestation of conformity. See section 3.2.2.

3.3 CE marking

The CE marking shall be affixed on the packaging or accompanying commercial document, e.g. the EC declaration of conformity. The letters "CE" shall be followed by the identification number of the approved certification body, where relevant, and be accompanied by the following additional information:

- the name and address of the producer (legal entity responsible for the manufacturer),
- the last two digits of the year in which the CE marking was affixed,
- the number of the EC certificate for the factory production control,
- the number of the European Technical Approval,
- use category (option 1),
- size of the anchor.

4 Assumptions under which the fitness of the product for the intended use was favourably assessed

4.1 Manufacture

The anchor is manufactured in accordance with the provisions of the European Technical Approval using the automated manufacturing process as identified in the inspection of the plant by Deutsches Institut für Bautechnik and the approved body and laid down in the technical documentation.

The European Technical Approval is issued for the product on the basis of agreed data/information, deposited with Deutsches Institut für Bautechnik, which identifies the product that has been assessed and judged. Changes to the product or production process, which could result in this deposited data/information being incorrect, should be notified to Deutsches Institut für Bautechnik before the changes are introduced. Deutsches Institut für Bautechnik will decide whether or not such changes affect the ETA and consequently the validity of the CE marking on the basis of the ETA and if so whether further assessment or alterations to the ETA shall be necessary.

4.2 Installation

4.2.1 Design of the fixings

The fitness of the anchor for the intended use is given under the following conditions:

- The Eternit-façade panels correspond to the specifications of Annex 8.
- Each façade panel is fixed with at least four anchors in a rectangular arrangement via single agraffes, double agraffes, long-span agraffes or panel load-bearing profiles according to the installation instructions on the substructure.
- The substructure is constructed such that the façade panels are fixed according to Annex 6 technically strain-free via sliding points (loose bearings) and one fixed point (fixed bearing); the fixed point may be placed at the panel edge or in the panel field.
- Two fixing points of the façade panel are designed such that they are able to carry the dead load of the façade panel.
- When using agraffes on horizontal load-bearing profiles the fixing points of a façade panel situated horizontally at the same height are fastened in each case to the same load-bearing profile.
- The thickness of the fixing member (agraffe or panel load-bearing profile) shall be at least 2.0 mm and must not exceed 3.0 mm.

- At the agraffes or panel load-bearing profiles shall be arranged one square hole with 10.2 mm x 10.2 mm (fixed point). Agraffes with two anchors shall provide one rectangular hole with the dimension 10.2 mm x 14.2 mm (sliding point). At the panel load-bearing profile shall be arranged further holes with the dimension 10.2 mm x 20 mm to ensure a strain-free bearing of the façade panels at the panel load-bearing profile. Annex 4 shows fixed points and loose points.
- The façade panels neither are used to transmit impact loads nor for guard rail.
- Joint construction between the façade panels is done by a joint filler or are kept open. It is ensured that additional stresses (e.g. by temperature) do not lead to important additional loadings.
- Taking account of the loads to be fixed checkable calculations and construction drawings are prepared. The position of the anchor is given in the construction drawing.
- The façade panels, their fixings as well as the substructure including its connection to wall brackets and their connection to the construction works are designed for the respective case of application under the responsibility of an engineer skilled in the field of façade construction taking account the following conditions:
 - The design values of the actions shall be calculated on basis of EN 1990 in consideration of the existing loads. The combinations of actions shall be equal to EN 1990. The actions shall be specified according to EN 1991-1-1 to EN 1991-1-7. Corresponding national regulations shall be taken into consideration. The unfavourable combination is decisive. Where necessary for the design of the anchor and the façade panel several combinations shall be analysed separately. The typical fundamental combination for façade panels considers actions from dead load $F_{Sk,G}$ (permanent action) and wind $F_{Sk,w}$ (leading variable action).
 - For installation of horizontal load-bearing profiles permanent loads due to torsion of the profile shall be considered in addition to actions from dead loads and wind in direction of the anchor axes. Simplifying these permanent loads can be determined as follows:

Load due to torsion of the load-bearing profile resulting from dead load of the façade slab

$$N_{Sk,V} = V_{Sk} \cdot 2e/c_H$$

with V_{Sk} = shear load due to dead load of the façade slab

e und c_H [mm] see Annex 4

The load due to torsion can be neglected, when there is no horizontal distance between anchor and vertical load-bearing profile.

- The calculation shall be carried out in a linear elastic manner. For the bending stress in the façade panels and for the anchors loads is to be verified, that the following equation is observed:

$$F_{Sd} \leq F_{Rk} / \gamma_M$$

with F_{Sd} [kN] = design value of the relevant existing force (N_{Sd} , V_{Sd} , σ_{Sd})

F_{Rk} [kN] = characteristic resistance to the relevant force (N_{Rd} , V_{Rd} , σ_{Rd}) according to Annex 4

γ_M [-] = partial safety factor according to Annex 5

In case of coincident stress of an anchor due to tension and shear load the equation according to Annex 5 is observed.

- For structural calculation by means of the Finite-Element-Method the façade panels are to be idealized with their effective dimensions (size and thickness) as panel elements. The system chosen shall have the capacity to sufficiently precise represent the tension and the deformation state as well as the support reactions of the façade panels. The relevant bending stress for the verification is obtained at the fixing range in a distance of $5h$ (h = panel thickness) from the anchor axis. The mesh size at fixing range shall be at least $0.75h$ and shall not exceed $2.5h$.
- For the design relevant characteristic values of the anchor (resistance, edge distances and spacing) and of the panel (bending strength, modulus of elastic, Poisson's ratio, dead load) shall be taken from Annex 5.
- The stiffness of the substructure will be considered for the respective case of application.

4.2.2 Installation of the anchors

The fitness for use of the anchor can be assumed only, if the following installation conditions are observed:

- During transport and storage on site the façade panels are protected from damages. The façade panels are not be hung up jerkily (if needed lifters shall be used for hanging up the façade panels). Façade panels and reveal panels respectively with incipient cracks are not to be installed.
- Installation of the façade by appropriately qualified personnel according to the installation instructions.
- Installation only as delivered by the manufacturer without exchanging the individual parts.
- Installation according to manufacturer's specifications and construction drawings using the tools indicated in the installation instructions.
- Keeping of the edge distance and spacing to the specified values.
- Making of the undercut drilling on the backside of the façade panels is done with the drill bit according to Annex 3 or a special CNC drilling device in accordance with the information deposited at Deutsches Institut für Bautechnik. The execution of the drilling is done at the factory or on site under workshop conditions; supervised by the responsible project supervisor or a skilled representative of the project supervisor.
- Cleaning of the drill hole.
- In case of aborted hole: new drilling at a minimum distance away of twice the depth of the aborted hole.
- Keeping of the embedment depth.
- The geometry of the drill hole is checked on 1 % of all drillings. The following dimensions shall be checked and documented according to manufacturer's information and testing instructions by means of the testing device according to Annex 3:
 - Volume of the undercut.
 - Depth of the undercut. The distance between the lower edge of the gauge and the façade plate is 0.0 -0.3 mm.

Note: Checking the geometry of the drill hole on 1% of all drillings means that one of 100 drillings shall be checked.

- Installation of the anchor in rectangular holes (sliding points) needs additional spring washers between anchor sleeve and washer.

5 Indications to the manufacturer

It is in the responsibility of the manufacturer to ensure that the information on the specific conditions according to 1 and 2 including Annexes referred to and 4.2.1 and 4.2.2 is given to those who are concerned. This information may be made by reproduction of the respective parts of the European Technical Approval. In addition all installation data shall be shown clearly on the package and/or on an enclosed instruction sheet, preferably using illustration(s).

The minimum data required are:

- drill hole depth
- thickness of the fixing member
- information on the installation procedure, including cleaning of the hole, preferably by means of an illustration

All data shall be presented in a clear and explicit form.

Georg Feistel
Head of Department

beglaubigt:
Bürger

Example of a façade panel with fixing member - single agraffe

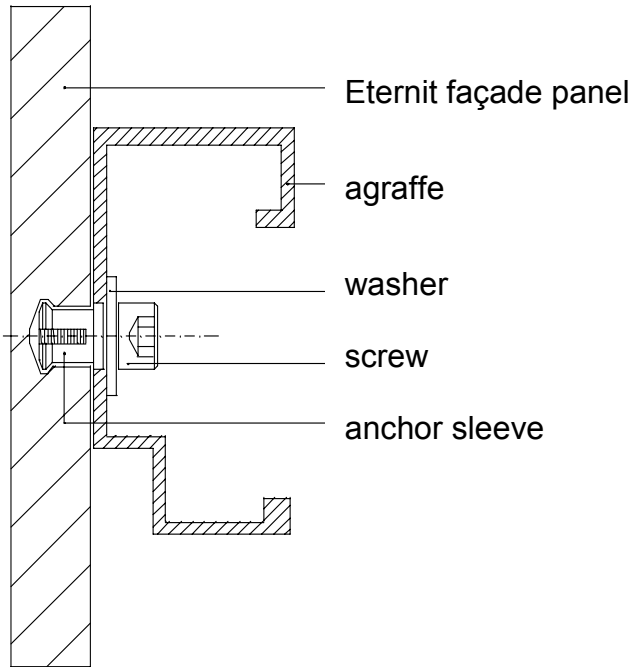

Example of a façade panel with fixing member - panel load-bearing profile

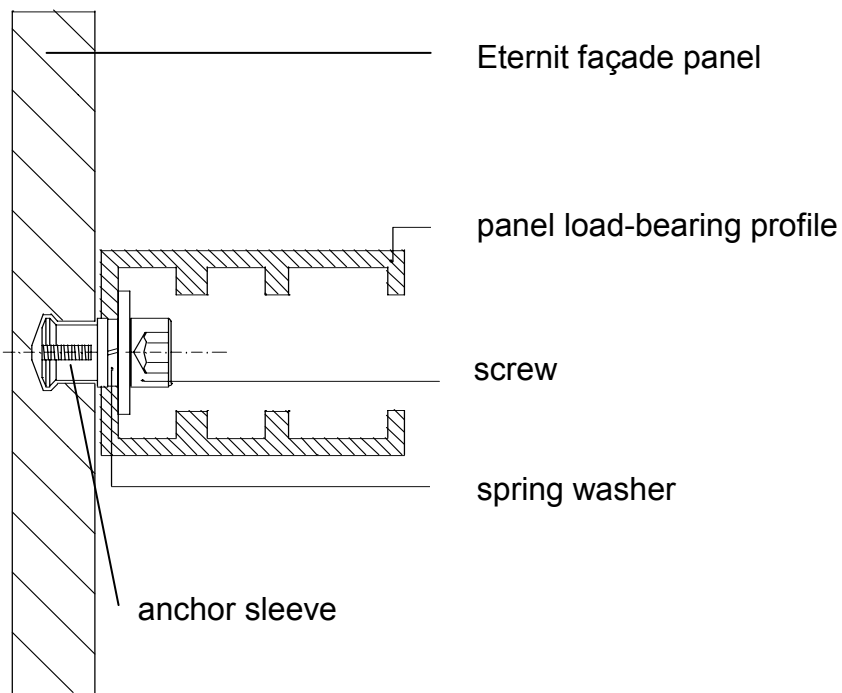

Eternit-Tergo-Hinterschnittanker für Eternit-Fassadentafeln

Product and intended use

Annex 1

System components

Combination 1: screw with washer

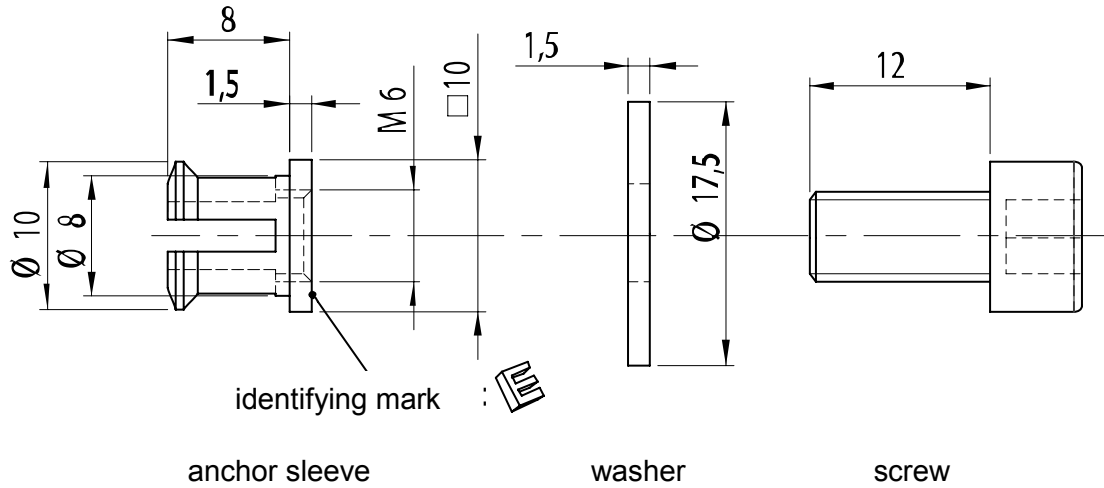

Combination 2: flat headed screw with integrated loose washer

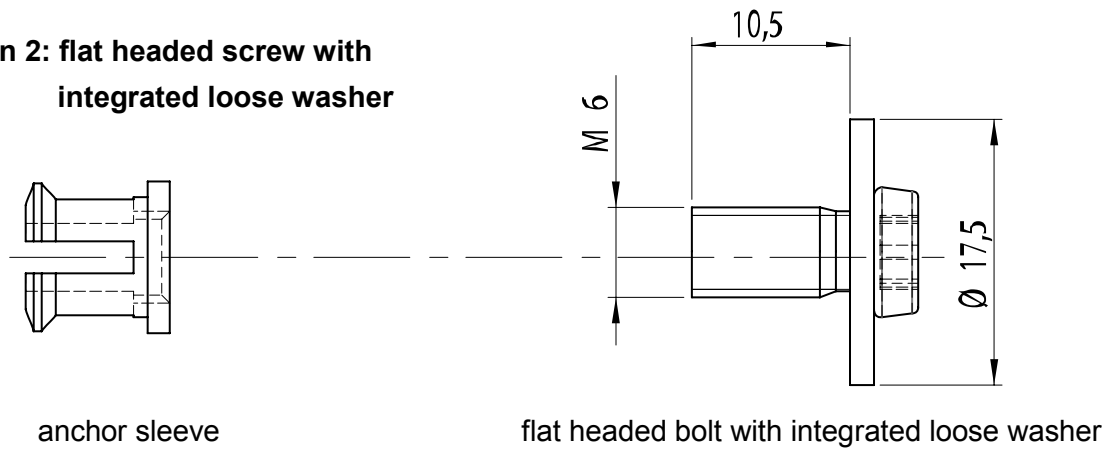

supplied anchor sleeve

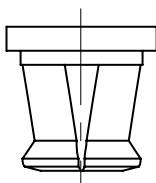

measurements in mm

Eternit-Tergo-Hinterschnittanker für Eternit-Fassadentafeln

System components and measurements

Annex 2

Drill and drill hole geometry

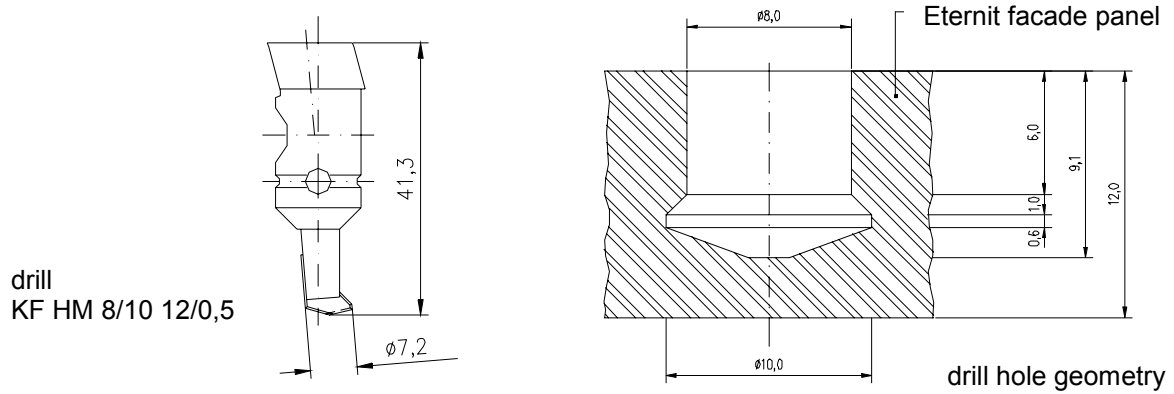

**Tergo
 Measuring device**

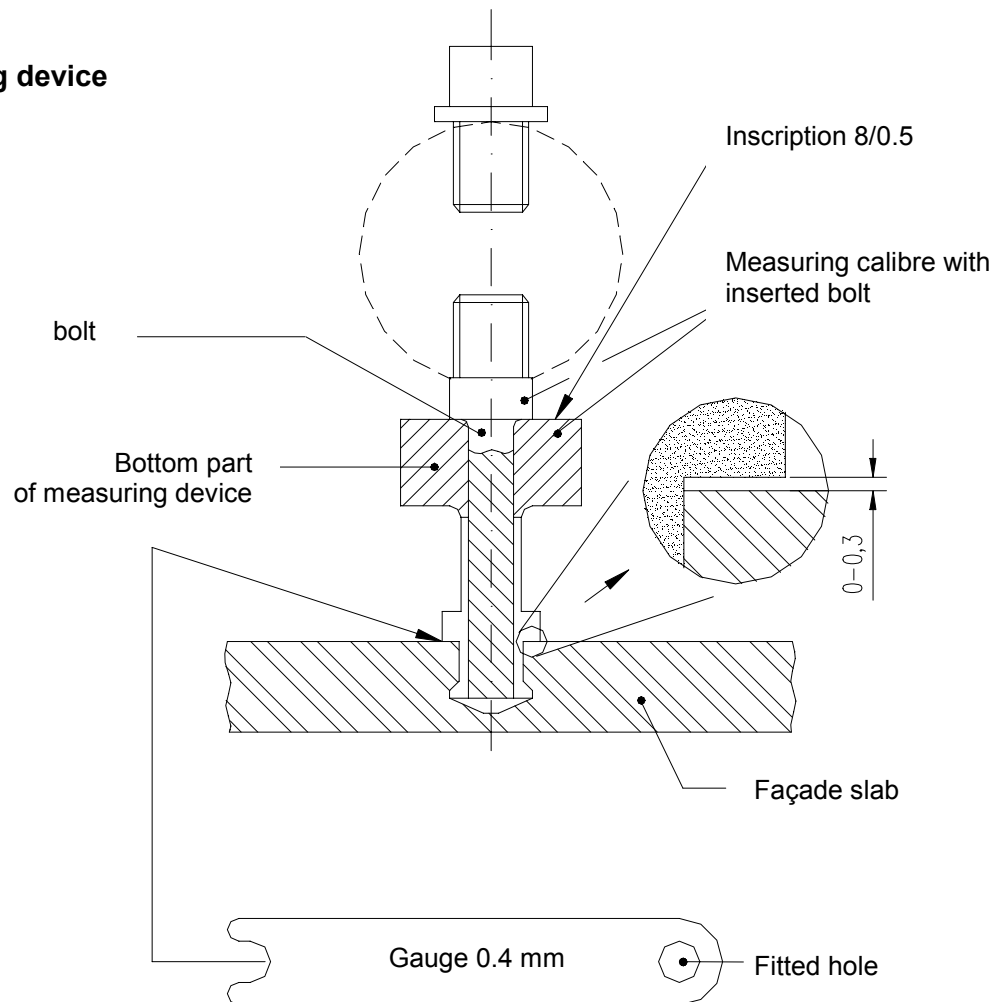

Eternit-Tergo-Hinterschnittanker für Eternit-Fassadentafeln

Drill and drill geometry, Tergo measuring device

Annex 3

Geometry of clearance hole at fixing member for fixed point (fixed bearing) and skid (loose bearing)

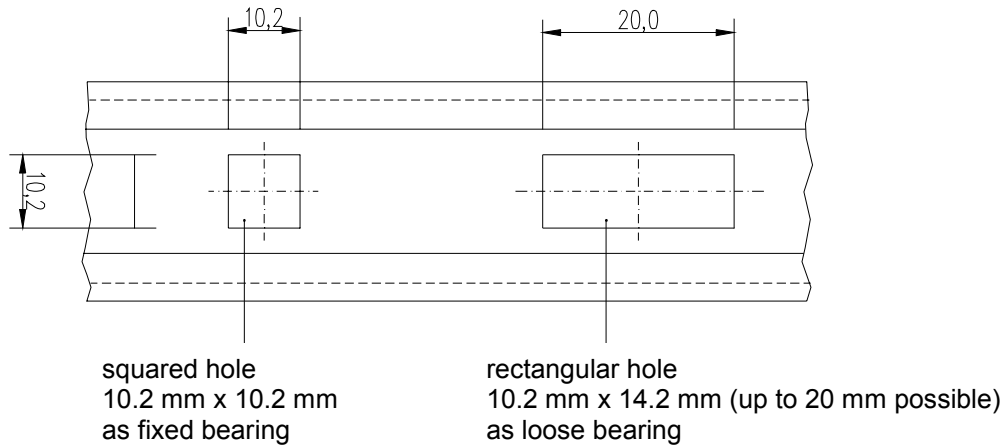

Note!

Installation of the anchor in rectangular holes of panel load-bearing profiles needs additional spring washers M6 DIN 7980 A2 between anchor sleeve and washer.

Torsion of horizontal load-bearing profiles resulting from dead load of the façade slabs

For flush fixed anchors and for installation of horizontal load-bearing profiles permanent loads due to torsion of the profile shall be considered in addition to actions from dead loads and wind in direction of the anchor axes. Simplifying these permanent loads can be determined as follows:

$$N_{Sk,v} = V_{Sk} \cdot 2e/c_H$$

V_{Sk} = shear load due to dead load of the façade slab

e und c_H [mm] see picture

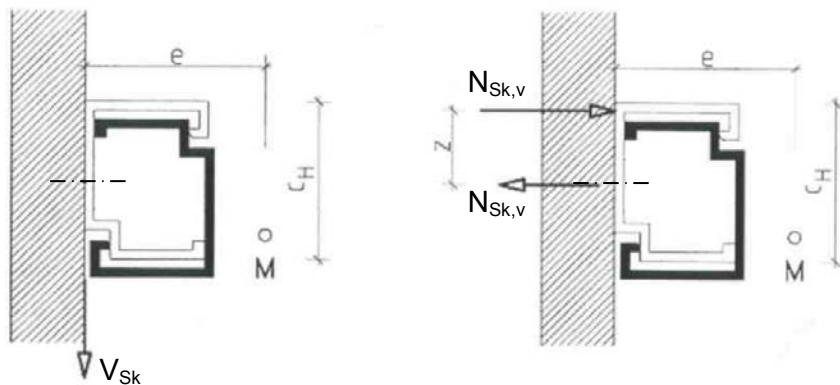

Eternit-Tergo-Hinterschnittanker für Eternit-Fassadentafeln

Geometry of clearance hole
 Torsion of horizontal load-bearing profiles

Annex 4

Table 1: Characteristic values for the design of the anchor and façade panel

characteristic values of panels Eternit façade panel	max. panel size	$L_x \times L_y$ $L_y \times L_x$	[mm x mm]	3100 x 1500
	nominal panel thickness	$h_{nom} =$	[mm]	12.0
	characteristic resistance bending	$\sigma_{Rk} =$	[N/mm ²]	16.2
	partial safety factor ¹⁾	$\gamma_M =$	[-]	1.8
	modulus of elasticity	$E =$	[N/mm ²]	15000
	Poisson's ratio	$\nu =$	[-]	0.25
	dead load	$g =$	[kN/m ²]	0.28
characteristic values of anchors Eternit-Tergo-undercut anchor	tension load ²⁾	characteristic resistance N_{Rk}	[kN]	1.2
		edge distance ³⁾ $a_r \geq$	[mm]	50
	spacing	[mm]	$100 \leq a \leq 750$	
	shear load ²⁾	characteristic resistance V_{Rk}	[kN]	2.4
		edge distance $a_r \geq$	[mm]	100
		spacing $a \geq$	[mm]	200
	partial safety factor ¹⁾	$\gamma_M =$	[-]	1.8

¹⁾ in absence of other national regulations

²⁾ In case of coincident stress of an anchor due to tension and shear load the following equation shall be observed:

$$\left(\frac{N_{Sd}}{N_{Rd}} \right)^{1,5} + \left(\frac{V_{Sd}}{V_{Rd}} \right)^{1,5} \leq 1$$

V_{Sd} is the dead load of the facade panel, acting on the anchor in vertical direction.

³⁾ The higher value is decisive.

Eternit-Tergo-Hinterschnittanker für Eternit-Fassadentafeln

Characteristic values for the design of the anchor and facade panel

Annex 5

Example of arrangement of fixing points

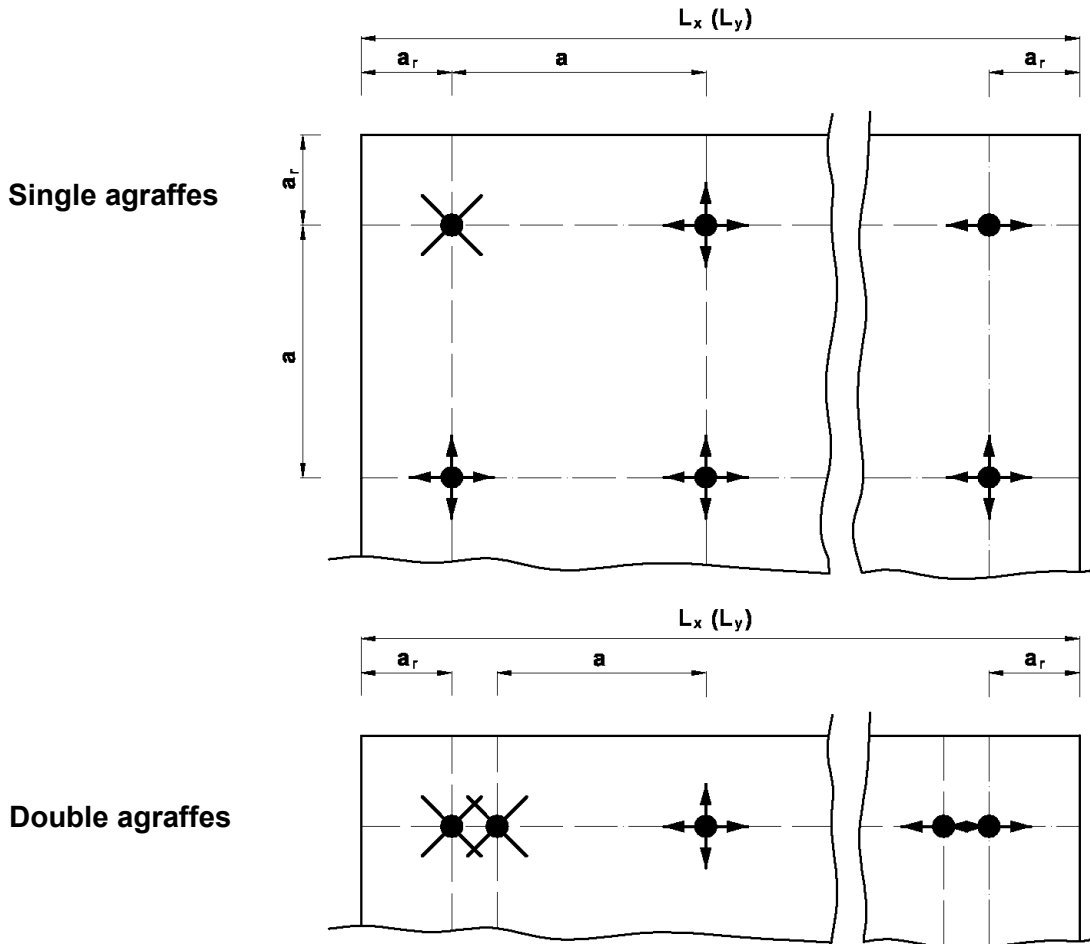

Legend:

a_r = edge distance – distance of an anchor to the panel edge

a = spacing – distance between anchors

L_x = length of the façade panel in horizontal direction

L_y = length of the façade panel in vertical direction

= fixed point (fixed bearing) between plate and substructure

= horizontal skid (loose bearing) between plate and substructure

= horizontal and vertical skid (loose bearing) between plate and substructure

Eternit-Tergo-Hinterschnittanker für Eternit-Fassadentafeln

Edge distances and spacing of the anchors
 Fixing points

Annex 6

Example of a façade construction with agraffes

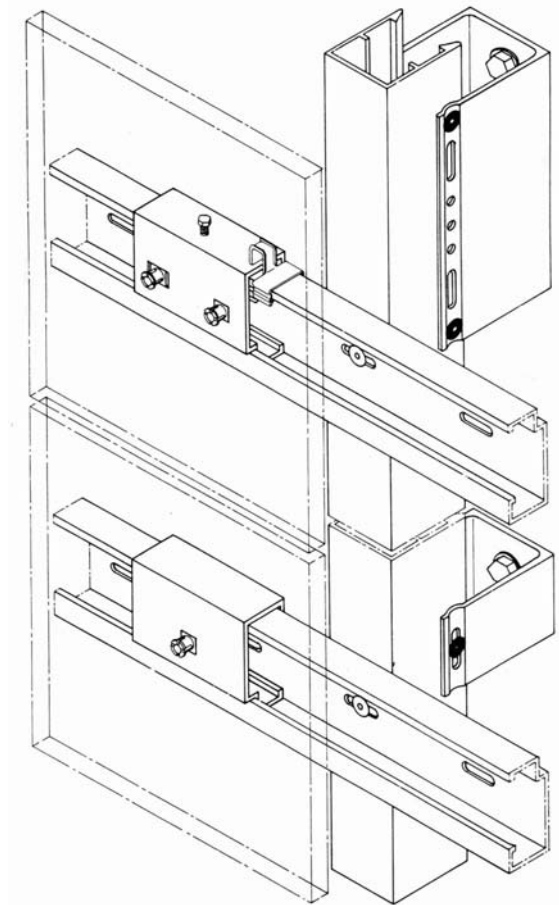
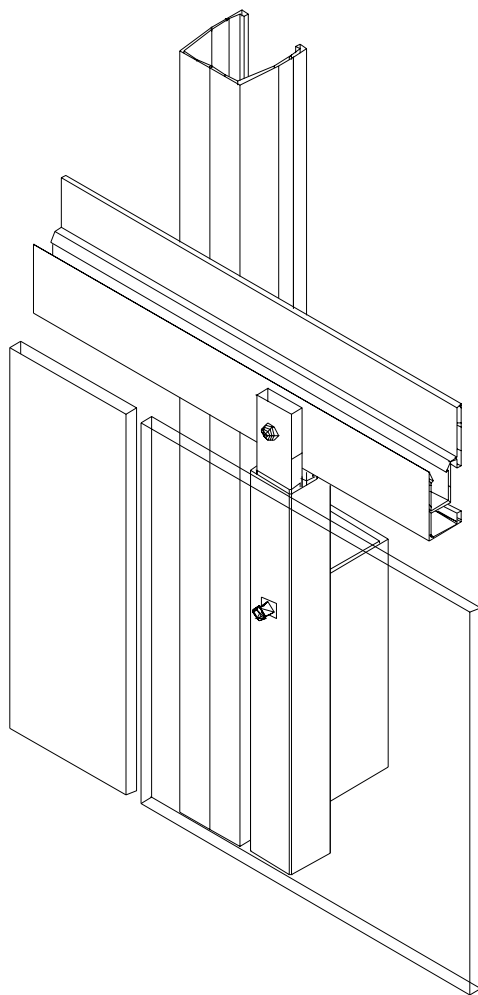

Example of a façade construction with panel load-bearing profiles

Eternit-Tergo-Hinterschnittanker für Eternit-Fassadentafeln

Examples of façade constructions

Annex 7

Requirements to the Eternit – façade panels

The Eternit-façade panels shall be classified according to EN 12467 "Fibre-cement flat sheets".

The façade panels shall fulfil the requirements of category B according to EN 12467 and shall correspond in their geometrical and physical properties to the requirements according to table 2.

The characteristic material values, dimensions and tolerances of the façade plates not indicated shall correspond to the respective values laid down in the technical documentation¹ of this European technical approval.

Table 2: characteristic values of the façade panels – geometrical and physical properties

panel thickness	minimum	$h_{\min} =$	[mm]	11.5
	maximum	$h_{\max} =$	[mm]	13.0
apparent density - dry		$\rho \geq$	[g/cm ³]	1.65
bending strength (crossways direction) without climatic pre-stressing ²⁾		$\sigma_{u5\%,0} \geq$	[N/mm ²]	17.8
bending strength (crossways direction) after climatic pre-stressing ³⁾		$\sigma_{u5\%,\text{cond}} \geq$	[N/mm ²]	14.6

¹⁾ 5%-Quantil by a confidence level of 75 % and unknown standard deviation

²⁾ testing after storage 7 days under normal ambient (20°C; 40-60% humidity)

³⁾ testing after conditioning according to EN 12467, Table 10 for category B

¹ The technical documentation comprises all information necessary for the production, installation and maintenance of the anchor; these are in particular the design drawings and the installation instructions. The part to be treated confidentially is deposited with Deutsches Institut für Bautechnik and, as far as this is relevant to the tasks of the approved bodies involved in the procedure of attestation of conformity, shall only be handed over to the approved body.

Eternit-Tergo-Hinterschnittanker für Eternit-Fassadentafeln	Annex 8
Requirements to the Eternit - façade panels	