

European Technical Approval ETA-11/0500

English translation prepared by DIBt - Original version in German language

Handelsbezeichnung
Trade name

Haas BSP Brettsperrholz
Haas CLT Cross Laminated Timber

Zulassungsinhaber
Holder of approval

Haas Holzprodukte GmbH
Industriestraße 8
84326 Falkenberg
DEUTSCHLAND

Zulassungsgegenstand
und Verwendungszweck

*Generic type and use
of construction product*

Massives plattenförmiges Holzbauelement zur Verwendung als
tragendes Bauteil in Bauwerken

Solid wood slab element to be used as a structural element in buildings

Geltungsdauer:
Validity:

vom
from
bis
to

10 November 2011

10 March 2014

Herstellwerk
Manufacturing plant

Holzindustrie Chanovice s.r.o.
Chanovice 102
CZ-34 101 Horazdovice
TSCHECHISCHE REPUBLIK

Diese Zulassung umfasst
This Approval contains

18 Seiten einschließlich 5 Anhänge
18 pages including 5 annexes

I LEGAL BASES AND GENERAL CONDITIONS

- 1 This European technical approval is issued by Deutsches Institut für Bautechnik in accordance with:
 - Council Directive 89/106/EEC of 21 December 1988 on the approximation of laws, regulations and administrative provisions of Member States relating to construction products¹, modified by Council Directive 93/68/EEC² and Regulation (EC) N° 1882/2003 of the European Parliament and of the Council³;
 - Gesetz über das In-Verkehr-Bringen von und den freien Warenverkehr mit Bauprodukten zur Umsetzung der Richtlinie 89/106/EWG des Rates vom 21. Dezember 1988 zur Angleichung der Rechts- und Verwaltungsvorschriften der Mitgliedstaaten über Bauprodukte und anderer Rechtsakte der Europäischen Gemeinschaften (Bauproduktengesetz - BauPG) vom 28. April 1998⁴, as amended by law of 31 October 2006⁵;
 - Common Procedural Rules for Requesting, Preparing and the Granting of European technical approvals set out in the Annex to Commission Decision 94/23/EC⁶.
- 2 Deutsches Institut für Bautechnik is authorized to check whether the provisions of this European technical approval are met. Checking may take place in the manufacturing plant. Nevertheless, the responsibility for the conformity of the products to the European technical approval and for their fitness for the intended use remains with the holder of the European technical approval.
- 3 This European technical approval is not to be transferred to manufacturers or agents of manufacturers other than those indicated on page 1, or manufacturing plants other than those indicated on page 1 of this European technical approval.
- 4 This European technical approval may be withdrawn by Deutsches Institut für Bautechnik, in particular pursuant to information by the Commission according to Article 5(1) of Council Directive 89/106/EEC.
- 5 Reproduction of this European technical approval including transmission by electronic means shall be in full. However, partial reproduction can be made with the written consent of Deutsches Institut für Bautechnik. In this case partial reproduction has to be designated as such. Texts and drawings of advertising brochures shall not contradict or misuse the European technical approval.
- 6 The European technical approval is issued by the approval body in its official language. This version corresponds fully to the version circulated within EOTA. Translations into other languages have to be designated as such.

¹ Official Journal of the European Communities L 40, 11 February 1989, p. 12

² Official Journal of the European Communities L 220, 30 August 1993, p. 1

³ Official Journal of the European Union L 284, 31 October 2003, p. 25

⁴ *Bundesgesetzblatt Teil I* 1998, p. 812

⁵ *Bundesgesetzblatt Teil I* 2006, p. 2407, 2416

⁶ Official Journal of the European Communities L 17, 20 January 1994, p. 34

II SPECIFIC CONDITIONS OF THE EUROPEAN TECHNICAL APPROVAL

1 Definition of product and intended use

1.1 Definition of the construction product

"Haas CLT Cross Laminated Timber" is a plane solid wood slab element made of at least 3 crosswise glued softwood boards. Adjacent layers are arranged perpendicular (angle of 90°) to each other. The cross-section of the solid wood slabs shall be symmetrically.

The principle structure of the solid wood slab is shown in Annex 1. Details, about which configurations are allowed, are given in chapter 2.1.2.

A maximum of three adjacent layers may be arranged in the same direction as long as a symmetric, crosswise jointed cross-section remains.

Surfaces are planed.

The elements may be covered on one or both sides with gypsum plasterboards, gypsum fibre boards, laminated veneer lumber (LVL) or oriented strand boards (OSB). These panels may not be used for calculation of the elements.

The application of chemical substances (wood preservatives and flame-protective agents) is not subject of this European technical approval.

1.2 Intended use

The solid wood slabs are intended to be used as a load-bearing, bracing or non structural element in buildings or timber structures. It shall be subjected to static and quasi static actions only.

The solid wood slab is intended to be used in service classes 1 and 2 according to EN 1995-1-1.

The provisions made in this European technical approval are based on an assumed working life of the solid wood slabs of 50 years, provided that the conditions laid down in section(s) 4.2, 5.1 and 5.2 for the packaging, transport, storage, installation, use, maintenance, repair are met. The indications given on the working life cannot be interpreted as a guarantee given by the producer, but are to be regarded only as a means for choosing the right products in relation to the expected economically reasonable working life of the works.

2 Characteristics of products and methods of verification

2.1.1 General

The solid wood slabs and their boards correspond to the information given in the annexes 1 to 3. Details about the elements are deposited at Deutsches Institut für Bautechnik.

2.1.2 Construction of the solid wood slab

A specification of the composition of the solid wood slabs and the boards to be used is given in Annex 1 and 2.

Boards are visually or machine strength graded. Only technically dried wood shall be used.

Only boards, which are planed on both sides shall be used. The boards can be connected by finger joints according to EN 385⁷ in longitudinal direction. Butt joints are not permissible.

The boards within a layer are glued together on their adjacent surfaces forming one-layer plates. The gaps between the one-layer plates are not glued. The acceptable width of gaps between the one-layer plates is given in Annex 2.

In case laminated veneer lumber is used, these boards must fulfill the specifications in EN 14374⁸ or EN 13986⁹ or a European technical approval.

In case oriented strand boards are used, these boards must fulfill the specifications in EN 13986⁹ or a European technical approval.

In case gypsum plasterboards or gypsum fibre boards are used, these boards must fulfill the specifications in EN 520¹⁰ or a European technical approval.

The gypsum plasterboards, gypsum fibre boards, laminated veneer lumber boards and oriented strand boards may not be used for calculation of the load-bearing capacity.

2.1.3 Adhesive

A PU - adhesive "Typ I" free of formaldehyde, fulfilling the requirements of EN 14080¹¹, Annex C, shall be used. For the classification EN 15425¹² applies.

2.2 Mechanical resistance and stability

The specifications regarding mechanical resistance and stability are given in annexes 2 to 5. Design of the slid wood slab elements can be carried out according to EN 1995-1-1.

2.3 Behaviour in case of fire

2.3.1 Reaction to fire

In accordance with Commission Decision 2003/43/EC the solid wood slab elements covered by this European technical approval for use as wall, roof, ceiling and special construction components comply with Euroclass D-s2, d0 according to EN 13501-1. For the use as floor construction components they comply with Euroclass D_i-s1. The boundary conditions stated in the commission decision have to be attended for this classification.

The Decision of the European Commission might not apply if wood-based panels or other coverings are part of the element, depending on the coverings used and the boundary conditions affected.

Note:

A European reference fire scenario for façades has not been laid down. In some Member States, the classification of the solid wood slabs according to EN 13501-1 might not be sufficient for the use in façades. An additional assessment of the solid wood slabs according to national provisions (e.g. on the basis of a large scale test) might be necessary to comply with Member State regulations, until the existing European classification system has been completed.

| | | |
|----|---------------|---|
| 7 | EN 385:2001 | Finger jointed structural timber - Performance requirements and minimum production requirements |
| 8 | EN 14374:2004 | Timber structures - Structural laminated veneer lumber - Requirements |
| 9 | EN 13986:2004 | Wood-based panels for use in construction - Characteristics, evaluation of conformity and marking |
| 10 | EN 520:2004 | Gypsum plasterboards - Definitions, requirements and test methods |
| 11 | EN 14080:2005 | Timber structures - Glued laminated timber - Requirements |
| 12 | EN 15425:2008 | Adhesives - One component polyurethane for load bearing timber structures - Classification and performance requirements |

2.4 Hygiene, health and the environment

A manufacturer's declaration has been submitted that no dangerous substances are used in the product regulated by this European technical approval.

Wood preservatives or flame retardants are not part of the European technical approval.

The class of formaldehyde is E1 according to EN 13986 with respect to solid wood slabs.

Note:

In addition to the specific clauses relating to dangerous substances contained in this European technical approval, there may be other requirements applicable to the products falling within its scope (e.g. transposed European legislation and national laws, regulations and administrative provisions). In order to meet the provisions of the Construction Products Directive, these requirements need also to be complied with, when and where they apply.

2.5 Methods of verification

The assessment of the fitness of the solid wood slab for the intended use in relation to the requirements for mechanical resistance and stability, for safety in case of fire, for hygiene, health and the environment, for protection against noise, for energy economy and heat retention, as well as for durability in the sense of these Essential has been made in compliance with the assessment rules for solid wood slabs agreed upon within EOTA.

3 Evaluation and attestation of conformity and CE marking

3.1 System of attestation of conformity

According to the Decision 97/176/EC¹³ of the European Commission for the product family system 1 of the attestation of conformity applies.

This system of attestation of conformity is defined as follows:

System 1: Certification of the conformity of the product by an approved certification body on the basis of:

(a) Tasks for the manufacturer:

- (1) factory production control;
- (2) further testing of samples taken at the factory by the manufacturer in accordance with a prescribed test plan;

(b) Tasks for the approved body:

- (3) initial type-testing of the product;
- (4) initial inspection of factory and of factory production control; continuous surveillance, assessment and approval of factory production control.

Note: Approved bodies are also referred to as "notified bodies".

¹³

Official Journal of the European Communities L 73/19 from 03/1997

3.2 Responsibilities

3.2.1 Tasks for the manufacturer

3.2.1.1 Factory production control

The manufacturer shall exercise permanent internal control of production. All the elements, requirements and provisions adopted by the manufacturer shall be documented in a systematic manner in the form of written policies and procedures, including records of results performed. This production control system shall insure that the product is in conformity with this European technical approval.

The manufacturer may only use constituent materials stated in the technical documentation of this European technical approval.

The factory production control shall be in accordance with the "Control plan relating to the European technical approval ETA-11/0500 issued on 10 November 2011" which is part of the technical documentation of this European technical approval. The control plan is laid down in the context of the factory production control system operated by the manufacturer and deposited with Deutsches Institut für Bautechnik.¹⁴

The results of factory production control shall be recorded and evaluated in accordance with the provisions of the control plan. The records include at least:

- Designation of the product, basic materials and components;
- Type of control or testing;
- Date of manufacture of the product and date of testing of the product or basic materials or components;
- Results of control and testing and, if appropriate, comparison with requirements;
- Name and signature of person responsible for factory production control.

3.2.1.2 Other tasks for the manufacturer

The manufacturer shall, on the basis of a contract, involve a body which is approved for the tasks referred to in section 3.1 in order to undertake the actions laid down in section 3.2.2 For this purpose, the control plan referred to in sections 3.2.1.1 and 3.2.2 shall be handed over by the manufacturer to the approved body involved.

The manufacturer shall make a declaration of conformity, stating that the construction product is in conformity with the provisions of the European technical approval ETA-11/0500 issued on 10 November 2011. The declaration of conformity can only be given if the provisions of this ETA are met and the control plan is being followed.

3.2.2 Tasks for the approved bodies

The approved body shall perform the

- initial type-testing of the product,
- initial inspection of factory and of factory production control,
- continuous surveillance, assessment and approval of factory production

in accordance with the provisions laid down in the control plan.

The initial inspection of the factory shall include the inspection of the factory plant, the technical equipment and the qualification of the staff.

¹⁴ The "control plan" is a confidential part of the European technical approval and only handed over to the approved body involved in the procedure of attestation of conformity. See section 3.2.2.

The approved body shall retain the essential points of its actions referred to above and state the results obtained and conclusions drawn in a written report.

The approved certification body involved by the manufacturer shall issue an EC certificate of conformity of the product stating the conformity with the provisions of this European technical approval. The certificate of conformity can only be given if the provisions of this ETA are met and the control plan is being followed.

In cases where the provisions of the European technical approval and its control plan are no longer fulfilled the certification body shall withdraw the certificate of conformity and inform Deutsches Institut für Bautechnik without delay.

3.3 CE marking

The CE marking shall be affixed on the product itself, a label attached to it, the packaging or the accompanying commercial document.

The letters "CE" shall be followed by the identification number of the approved certification body and be accompanied by the following additional information:

- the name and address of the producer (legal entity responsible for the manufacture),
- the last two digits of the year in which the CE marking was affixed,
- the number of the EC certificate of conformity for the product,
- the number of the European technical approval,
- description of the element, showing its intended use,
- species of the wood used,
- number and arrangement of the layers,
- nominal thickness of the element,
- strength class of the wood of each layer,
- class of formaldehyde (if required),
- type and classification of the adhesive used

For the CE marking of laminated veneer lumber (LVL), oriented strand boards (OSB), gypsum plasterboards and gypsum fibre boards used within the element the regulations provided in the associated harmonised European standards or European technical approvals shall be observed. The CE Marking for this products shall be kept separated from the CE Marking according to this European technical approval.

4 Assumptions under which the fitness of the products for the intended use was favourably assessed

4.1 Manufacturing

The solid wood slabs are manufactured in accordance with the provisions of this European technical approval using the automated manufacturing process as identified in the inspection of the plant by the Deutsches Institut für Bautechnik and laid down in the technical documentation. The layers shall be glued together to the required thickness of the solid wood slabs.

The elements are manufactured by clamping and gluing, whereas each layer is clamped. Alternative the elements may be manufactured by vacuum pressing adhesion. Details regarding the manufacturing process are deposited with Deutsches Institut für Bautechnik.

The European technical approval is issued for the product on the basis of agreed data/information, deposited with Deutsches Institut für Bautechnik, which identifies the product that has been assessed and judged. Changes to the product or production process, which could result in this deposited data/information being incorrect, should be notified to Deutsches Institut für Bautechnik before the changes are introduced. Deutsches Institut für Bautechnik will decide whether or not such changes affect the approval and consequently the validity of the CE marking on the basis of the approval and if so whether further assessment or alterations to the approval shall be necessary.

4.2 Installation

4.2.1 Design of solid wood slab elements

The European technical approval only applies to the manufacture and use of the solid wood slabs regulated here. Verification of stability of the buildings while using the solid wood slab elements is not subject of this European technical approval.

Fitness for the intended use of the solid wood slab is given under the following conditions:

- Design of the solid wood slab elements is carried out under the responsibility of an engineer experienced in these elements.
- Design of the works provides a sufficient protection of the solid wood slab elements.
- The solid wood slab elements are installed correctly.

Design of the solid wood slab elements can be performed according to EN 1995-1-1 taking into account the Annexes 2 to 5 of this European technical approval. Standards and regulations valid in the place of use shall be considered.

4.2.2 Installation of solid wood slab elements

The manufacturer shall prepare assembling instructions in which the product-specific characteristics and important measures to be taken into consideration for assembling are described. The assembling instructions shall be available at every construction site.

The assembling of solid wood slab elements shall be carried out by appropriately qualified personnel.

Elements which are directly exposed to the weather shall be provided with an effective protection for the solid wood slab element during assembling and service.

5 Indications to the manufacturer

5.1 General

The manufacturer shall ensure that the requirements stated in the clauses 1, 2 and 4 and the annexes of this European technical approval are made known to those who are concerned during planning and execution of the works.

5.2 Recommendations on packaging, transport and storage

The solid wood slab elements shall be protected during transport and storage against any damage and detrimental moisture effects. The manufacturer's instruction for packaging, transport and storage shall be observed.

5.3 Use, maintenance, repair

The assessment of the fitness for use is based on the assumption that maintenance is not required during the assumed intended working life. In case of a severe damage of a solid wood slab element immediate actions regarding the mechanical resistance and stability of the works shall be initiated. Should this situation arise replacement of the elements can be necessary.

Georg Feistel
Head of Department

beglaubigt:
Niebur

Annex 1

Construction of the wood slab elements

Construction of the wood slab elements "Haas CLT Cross Laminated Timber" (example)

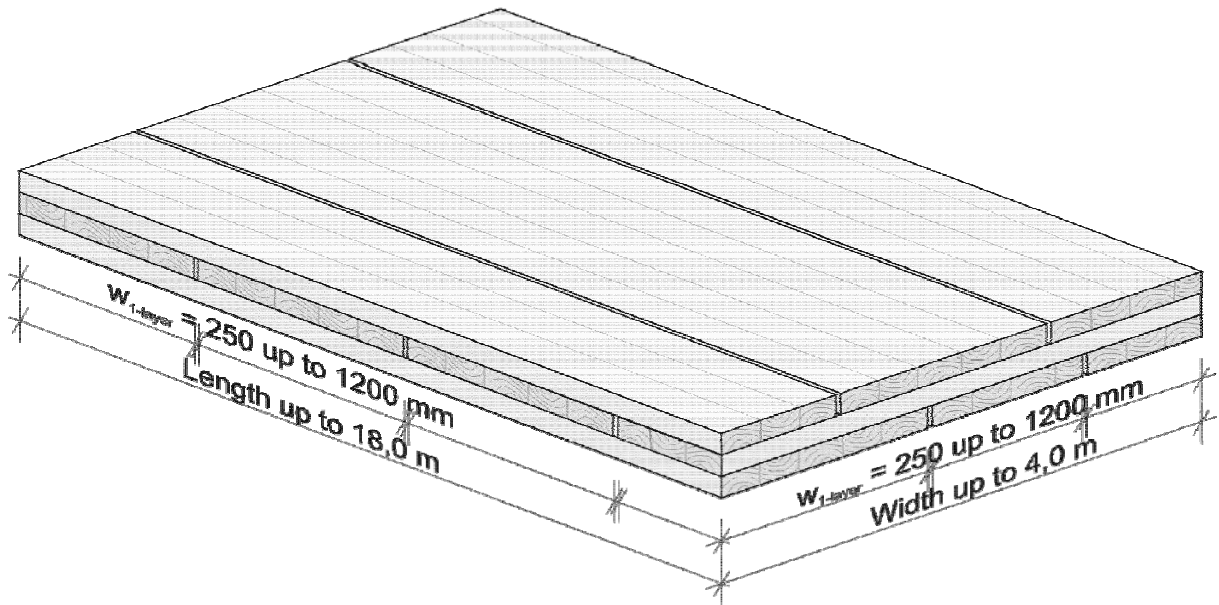

Thickness
60 up to 400 mm

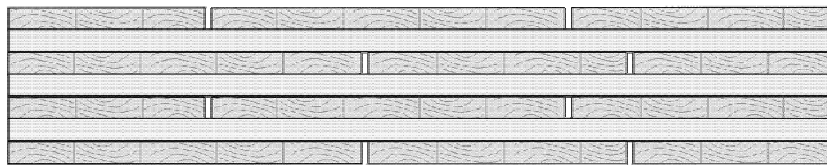

Overlap
 ≥ 100 mm

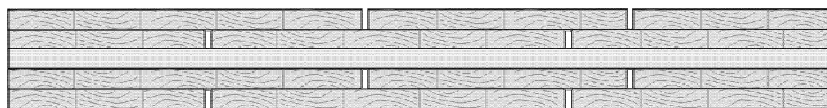

| | |
|----------------|--|
| Annex 2 | Dimensions and specifications of the wood slab elements |
|----------------|--|

Table 1: Dimensions and specifications of the elements

| Characteristic | Specification |
|--|--------------------|
| Elemente | |
| Thickness | 60 to 280 mm |
| Tolerance in thickness | ± 0.5 mm |
| Width | ≤ 4.00 m |
| Tolerance in width | ± 1 mm |
| Length | ≤ 18.00 m |
| Tolerance in length | ± 2.0 mm |
| Number of layers | $3 \leq n \leq 25$ |
| Number of consecutive layers having the same direction | ≤ 3 for $n > 5$ |
| Maximum width of gaps between the one-layer plates | |
| - between 10 % of the plates | 2 mm |
| - between 3 % of the plates | 4 mm |
| One-layer plates | |
| Material | softwood |
| Strength class according to EN 338 ¹⁵ | ≥ C16* |
| Thickness | 15 to 45 mm |
| Width | 250 to 1200 mm |
| Ratio width to thickness of the cross-layers | ≥ 4:1 |
| Moisture of wood according to EN 13183-2 ¹⁶ | $12 \pm 2 \%$ |
| <p>* Within each layer a maximum of 10% of the boards may belong to a lower strength class without being considered. The following combinations are possible: 100% C 16; 90% C24 / 10% C16; 90% C30 / 10% C24; 90% C35 / 10% C30 and 90% C40 / 10% C35.</p> | |

¹⁵ EN 338:2003
¹⁶ EN 13183-2:2002

Timber structures - Strength classes
Moisture content of a piece of sawn timber - Part 2: Estimation by electrical resistance method

| | |
|----------------|---|
| Annex 3 | Essential Requirements of the wood slab elements |
|----------------|---|

Table 2: Essential Requirements of the solid wood slabs

| ER | Requirement | Verification method | Class / Use category / value | | |
|--|--|--|--|--------------|------------------------|
| Mechanical resistance and stability | | | | | |
| 1 | Mechanical actions in plane of the solid wood slab | For the calculation the characteristic strength and stiffness values of softwood according to EN 338 shall be used taking into consideration the definitions in annex 2. In addition the following values apply: | | | |
| | | | Rolling shear strength (5% - fractile) | $f_{R,k}$ | 1.25 N/mm ² |
| | | | Rolling shear modulus (mean value) | $G_{R,mean}$ | 50 N/mm ² |
| | Mechanical actions perpendicular to the solid wood slab | | For references regarding the calculation see annexes 4 to 5. National regulations might have to be followed. | | |
| | Use of fasteners | According to EN 1995-1-1, for further details see annex 4 | | | |
| Creep and duration of load | According to EN 1995-1-1 | | | | |
| Dimensional stability | Moisture content during use shall not change to such extent that adverse deformations can occur. | | | | |
| Behaviour in case of fire | | | | | |
| Reaction to fire | | | | | |
| 2 | Solid wood panels except for floorings | Commission Decision 2003/43/EC | Euroclass D-s2, d0 | | |
| | Floorings | | Euroclass D _{fl} -s1 | | |
| Resistance to fire | | | | | |
| | Charring rate | EN 1995-1-2 | No performance determined | | |
| Hygiene, health and the environment | | | | | |
| 3 | Vapour permeability μ | EN 12524 ¹⁷ | 20 to 50 | | |
| | Release of formaldehyde | EN 13986 with respect to solid wood slabs | Class E1 | | |
| Safety in use | | | | | |
| 4 | Slipperiness | | No performance determined | | |
| | Impact resistance | | No performance determined | | |

¹⁷

EN 12524:2000

Building materials and products - Hygrothermal properties - Tabulated design values

| | |
|----------------|---|
| Annex 3 | Essential Requirements of the wood slab elements |
|----------------|---|

Continue of Table 2:

| Protection against noise | | | |
|--|--------------------------------|---------------------------|----------------------------|
| 5 | Airbourne sound insulation | No performance determined | |
| | Impact sound insulation | No performance determined | |
| | Sound absorption | No performance determined | |
| Energy economy and heat retention | | | |
| 6 | Thermal conductivity λ | EN 12524 | 0.13 W/(m ² ·K) |
| | Air tightness | | No performance determined |
| | Thermal inertia c_p | EN 12524 | 1600 J/(kg·K) |
| Durability | | | |
| - | Use only in service classes | EN 1995-1-1 | 1 and 2 |

| | |
|----------------|---|
| Annex 4 | Recommendations for the design of the elements and the fasteners |
|----------------|---|

Recommendations for design and calculation of the elements and fasteners

1 Recommendations for design of the elements

1.1 General

Design, calculation and realization can be done according to EN 1995-1-1 taking into account the following provisions. For the calculation according to EN 1995-1-1 national regulations may have to be followed.

The determination of the distribution of stresses and internal forces must consider the influence of shear deformations. In annex 5 advice is given on how to perform the calculation of the elements.

If using panels as cover, the deformation of the covers might have to be taken into account. These cover layers may not be used for calculation of the elements.

1.2 Characteristic values

The characteristic strength and stiffness values can be taken from the annexes 2 and 3. In addition the following applies:

While calculating the part of the deformation due to shear forces, the element's thickness D regardless of the configuration and a shear modulus of $G = 60 \text{ N/mm}^2$ may be used.

1.3 Mechanical actions perpendicular to element plane

1.3.1 Bending and shear

For the calculation of the characteristic values of the element according to annex 5, only the boards, which are oriented parallel to the direction of load, might be considered.

For the verification of the bending strength of a layer the design value of the bending strength might be multiplied with a system factor k_ℓ :

$$k_\ell = \min \begin{cases} 1 + 0.025 \cdot n \\ 1.1 \end{cases}$$

with n = number of boards lying side by side.

1.3.2 Tension and compression

The behaviour in bearing and deformation against compression perpendicular to the element's plane can be calculated according to EN 1995-1-1 using the strength and stiffness values given in chapter 1.2.

Tension loads perpendicular to the element should be avoided.

1.4 Mechanical actions in plane of the element

For loads in plane of the element only layers can be taken into account, where the direction of the grain is parallel to the stresses occurring from external loads.

| | |
|----------------|---|
| Annex 4 | Recommendations for the design of the elements and the fasteners |
|----------------|---|

1.4.1 Shear

If forces between adjacent boards of a layer are transmitted only by means of using the next layer glued crosswise, the shear stresses in the crossing surfaces have to be calculated as follows:

$$\tau_{T,d} = \frac{F_d \cdot h}{\sum I_p} \cdot \frac{a}{2} \leq f_{v,d}$$

with

F_d = external load of the element (N)

h = height of the wall (mm)

a = largest side length of the crossing area (mm)

I_p = polar moment of inertia of a certain crossing area i (mm⁴)

$\sum I_p$ = sum of all polar moments of inertia of the crossing areas in the element

$f_{v,d}$ = design value of the torsional shear strength; the characteristic value shall be set to $f_{v,k} = 2.5$ N/mm² for this calculation

$\tau_{T,d}$ = design value of the torsional stresses occurring if boards of one layer are not glued on their lateral sides

In addition it has to be verified that the layers can bear the stresses falling upon them.

1.4.2 Tension and compression

The behaviour in bearing and deformation in the element's plane can be calculated according to EN 1995-1-1 using the strength and stiffness values given in chapter 1.2.

2 Recommendations for the design of the fasteners

2.1 General

The determination of characteristic values of the load-bearing capacity of fasteners in the element shall be carried out according to EN 1995-1-1 or a European technical approval which has been granted for the relevant fastener as for softwood or for glued laminated timber. For the calculation according to European regulations national provisions may apply.

Side surfaces are the surfaces of the element parallel to the plane of the element.

Lateral surfaces are the surfaces perpendicular to the plane of the element, consisting of the lateral surfaces and the cross grain of the boards.

As fasteners nails, wood screws, bolts and dowels, split ring and toothed-plate connectors according to EN 1995-1-1 or a European technical approval may be used.

| | |
|----------------|---|
| Annex 4 | Recommendations for the design of the elements and the fasteners |
|----------------|---|

2.2 Bolts and dowels

The characteristic value of junctions with bolts and dowels in the side surfaces can be calculated according to EN 1995-1-1.

Decisive for the embedment strength is the direction of the grain of the surface layer. The characteristic embedment strength of "Haas CLT Cross Laminated Timber" can be calculated by:

$$f_{h,\alpha,k} = \frac{32 \cdot (1 - 0.015 \cdot d)}{1.1 \cdot \sin^2 \alpha + \cos^2 \alpha} \text{ in N/mm}^2$$

with

d = Diameter of the fastener in mm

α = Angle between direction of the force and direction of the grain of the surface layer.

Bolts and dowels in the lateral surfaces of the "Haas CLT Cross Laminated Timber" might not be taken into consideration as load-bearing.

The minimum distance and spacing for bolts and dowels must be 5 · d from the loaded edge and between each other and 3 · d from the unloaded edge. This applies regardless of the angle between the direction of force and the direction of the grain.

2.3 Nails

The characteristic value of the load-bearing capacity of nails in the side surfaces can be calculated according to EN 1995-1-1.

The characteristic value of the embedment strength of not predrilled "Haas CLT Cross Laminated Timber" can be calculated by:

$$f_{h,k} = 60 \cdot d^{-0.5} \text{ in N/mm}^2$$

with

d = Diameter of the nail in mm.

Decisive for the minimum spacing between the nails is the direction of the grain of the side surfaces.

Nails in the lateral surfaces of "Haas CLT Cross Laminated Timber" might not be taken into consideration as load-bearing.

The diameter of nails must be at least 4 mm. Only grooved nails with a characteristic value of the point side withdrawal strength $f_{ax,k} \geq 50 \cdot 10^{-6} \cdot \rho_k^2$ and a characteristic value of the head side pull-through strength $f_{head,k} \geq 100 \cdot 10^{-6} \cdot \rho_k^2$ might be employed for axial loading (ρ_k = characteristic density in kg/m³; max. 500).

| | |
|----------------|---|
| Annex 4 | Recommendations for the design of the elements and the fasteners |
|----------------|---|

2.4 Screws

The characteristic value of the load-bearing capacity of screws in the side surfaces of the board can be calculated according to EN 1995-1-1.

The characteristic value of the embedment strength of not predrilled "Haas CLT Cross Laminated Timber" can be calculated by:

$$f_{h,k} = 60 \cdot d^{-0.5} \text{ in N/mm}^2 \text{ in N/mm}^2$$

with

d = diameter of the screw thread in mm.

For calculation of screws in the cross grain of the lateral surfaces the characteristic embedment strength of not predrilled "Haas CLT Cross Laminated Timber" is calculated by

$$f_{h,k} = \frac{32 \cdot d^{-0.3}}{2.5 \cdot \cos^2 \varepsilon + \sin^2 \varepsilon} \text{ in N/mm}^2$$

with

d = diameter of the screw thread in mm und

ε = Angle between direction of the grain and axis of the screw.

Decisive for the minimum spacing of the screws is the direction of the grain of the side surfaces.

The characteristic load-bearing capacity of axially loaded screws in the side surfaces can be calculated according to EN 1995-1-1.

For axially loaded screws in the cross grain of lateral surfaces the parameter $f_{ax,k}$ has to be decreased by 25 %.

Laterally or axially loaded screws in the side surfaces must have a diameter of at least 6 mm, in the lateral surfaces with cross layers it must be at least 8 mm.

In case the position of a screw within the lateral surface is not definitely clear (gap, cross grain, etc.) the worst case shall be assumed.

2.5 Split ring connectors and toothed-plate connectors

The characteristic value of the load-bearing capacity of split ring connectors and toothed-plate connectors in the side surfaces of the board can be calculated according to EN 1995-1-1.

For split ring connectors in the lateral surfaces the regulations for connections with split ring connectors in the cross grain apply.

Toothed-plate connectors in the lateral surfaces might not be taken into consideration as load-bearing.

| | |
|----------------|---|
| Annex 5 | Recommendations for the design of the elements and the fasteners |
|----------------|---|

Design according to the theory of flexible bonded beams

The calculation of elements with up to five layers can be performed using the theory of flexible bonded beams as described in EN 1995-1-1.

To consider deformations due to shear the factor s_i/K_i according to the standard is substituted by the factor $\bar{h}_i/(G_R \cdot b)$.

The effective moment of inertia is calculated by:

$$I_{ef} = \sum_{i=1}^3 (I_i + \gamma_i \cdot A_i \cdot a_i^2) \quad \text{with} \quad A_i = b_i \cdot h_i; \quad I_i = \frac{b_i \cdot h_i^3}{12}$$

$$\gamma_1 = \frac{1}{1 + \frac{\pi^2 \cdot E_0 \cdot A_1 \cdot \bar{h}_1}{G_R \cdot b \cdot l^2}}; \quad \gamma_2 = 1; \quad \gamma_3 = \frac{1}{1 + \frac{\pi^2 \cdot E_0 \cdot A_3 \cdot \bar{h}_2}{G_R \cdot b \cdot l^2}}$$

$$a_1 = \left(\frac{h_1}{2} + \bar{h}_1 + \frac{h_2}{2} \right) - a_2; \quad a_3 = \left(\frac{h_2}{2} + \bar{h}_2 + \frac{h_3}{2} \right) + a_2$$

$$a_2 = \frac{\gamma_1 \cdot A_1 \cdot \left(\frac{h_1}{2} + \bar{h}_1 + \frac{h_2}{2} \right) - \gamma_3 \cdot A_3 \cdot \left(\frac{h_2}{2} + \bar{h}_2 + \frac{h_3}{2} \right)}{\sum_{i=1}^3 (\gamma_i \cdot A_i)}$$

The verification of the bending performance is done by determination of the bending stress at the boundary of the boards. The bending stress in the middle of the boards may remain unconsidered.

$$\sigma_{m,r,i,d} = \pm \frac{M_d}{I_{ef}} \cdot \left(\gamma_i \cdot a_i + \frac{h_i}{2} \right) \leq f_{m,d}$$

The verification of the shear performance is done by determination of the shear stress in the decisive plane:

$$\tau_{v,d} = \frac{V_d \cdot \gamma_i \cdot S_i}{I_{ef} \cdot b} \leq f_{R,d}$$

Legend:

- h_{tot} = thickness of the whole element [mm]
- h_i = thickness of the layer i parallel to the direction of load transfer [mm]
- \bar{h}_i = thickness of the layer i perpendicular to the direction of load transfer [mm]
- b = width of the element [mm]
- n = number of layers
- l = span width [mm]
- I_{ef} = effective moment of inertia [Nmm²]
- G_R = rolling shear modulus [N/mm²]
- E_0 = modulus of elasticity parallel to the grain of the boards [N/mm²]