

European Technical Approval ETA-11/0145

English translation prepared by DIBt - Original version in German language

Handelsbezeichnung
Trade name

fischer-Zykon-Plattenanker FZP II
fischer-Zykon-panel anchor FZP II

Zulassungsinhaber
Holder of approval

fischerwerke GmbH & Co. KG
Weinhalde 14 -18
72178 Waldachtal
DEUTSCHLAND

Zulassungsgegenstand
und Verwendungszweck
*Generic type and use
of construction product*

Spezialanker zur rückseitigen Befestigung von Fassadenplatten aus
ausgewählten Naturwerksteinen nach EN 1469
*Special Anchor for the rear fixing of façade panels made of selected
natural stones according to EN 1469*

Geltungsdauer:
Validity: vom
from
bis
to

5 April 2011
5 April 2016

Herstellwerk
Manufacturing plant

fischerwerke

Diese Zulassung umfasst
This Approval contains

28 Seiten einschließlich 19 Anhänge
28 pages including 19 annexes

I LEGAL BASES AND GENERAL CONDITIONS

- 1 This European technical approval is issued by Deutsches Institut für Bautechnik in accordance with:
 - Council Directive 89/106/EEC of 21 December 1988 on the approximation of laws, regulations and administrative provisions of Member States relating to construction products¹, modified by Council Directive 93/68/EEC² and Regulation (EC) N° 1882/2003 of the European Parliament and of the Council³;
 - Gesetz über das In-Verkehr-Bringen von und den freien Warenverkehr mit Bauprodukten zur Umsetzung der Richtlinie 89/106/EWG des Rates vom 21. Dezember 1988 zur Angleichung der Rechts- und Verwaltungsvorschriften der Mitgliedstaaten über Bauprodukte und anderer Rechtsakte der Europäischen Gemeinschaften (Bauproduktengesetz - BauPG) vom 28. April 1998⁴, as amended by law of 31 October 2006⁵;
 - Common Procedural Rules for Requesting, Preparing and the Granting of European technical approvals set out in the Annex to Commission Decision 94/23/EC⁶.
- 2 Deutsches Institut für Bautechnik is authorized to check whether the provisions of this European technical approval are met. Checking may take place in the manufacturing plant. Nevertheless, the responsibility for the conformity of the products to the European technical approval and for their fitness for the intended use remains with the holder of the European technical approval.
- 3 This European technical approval is not to be transferred to manufacturers or agents of manufacturers other than those indicated on page 1, or manufacturing plants other than those indicated on page 1 of this European technical approval.
- 4 This European technical approval may be withdrawn by Deutsches Institut für Bautechnik, in particular pursuant to information by the Commission according to Article 5(1) of Council Directive 89/106/EEC.
- 5 Reproduction of this European technical approval including transmission by electronic means shall be in full. However, partial reproduction can be made with the written consent of Deutsches Institut für Bautechnik. In this case partial reproduction has to be designated as such. Texts and drawings of advertising brochures shall not contradict or misuse the European technical approval.
- 6 The European technical approval is issued by the approval body in its official language. This version corresponds fully to the version circulated within EOTA. Translations into other languages have to be designated as such.

¹ Official Journal of the European Communities L 40, 11 February 1989, p. 12
² Official Journal of the European Communities L 220, 30 August 1993, p. 1
³ Official Journal of the European Union L 284, 31 October 2003, p. 25
⁴ *Bundesgesetzblatt Teil I 1998*, p. 812
⁵ *Bundesgesetzblatt Teil I 2006*, p. 2407, 2416
⁶ Official Journal of the European Communities L 17, 20 January 1994, p. 34

II SPECIFIC CONDITIONS OF THE EUROPEAN TECHNICAL APPROVAL

1 Definition of product/ products and intended use

1.1 Definition of the construction product

The fischer-Zykon-panel anchor FZP II is a special anchor of sizes M 6 and M 8 which consists of a cone bolt (with external thread or internal thread), an expansion part, a sleeve and, if need be, a nut. Cone bolt and expansion part are made of stainless steel. The sleeve is made of stainless steel or carbon. The nut is made of stainless steel or aluminium. The anchor is put into an undercut drill hole and by driving-in of the sleeve it is placed form-fit.

Annex 1 shows the anchor at built-in state.

1.2 Intended use

The anchor may only be used for the rear fixing of façade slabs of natural stone according to EN 1469:2004. The façade slabs shall correspond to EN 1469:2004, the drawings and to the indications given in the annexes and shall only be made of the natural stones according to Table 1. It must be ensured that the material used is free of crevices and mechanical effective cracks and alterations.

Table 1: Selected natural stones

Group of stone		Natural stones
I	High-quality intrusive rocks (plutonic rocks)	e.g.: granite, granitite, syenite, tonalite, diorite, monzonite, gabbro
II	Metamorphic rocks with "hard stone character"	e.g.: quartzite, granulite, gneiss, migmatite
III	High-quality extrusive rocks (volcanic rocks) ⁷	basalt and basaltlava
IV	Sedimentary rocks with "hard stone character" ^{8 9}	sandstone and limestone

The façade slabs with rear fixing by the anchor may only be used for front curtain walls. As a rule each façade slab shall be fixed technically restrain-free with four anchors in a rectangular arrangement on a capable substructure.

The anchor may be used in structures subject to dry internal conditions and also in structures subject to external atmospheric exposure (including industrial and marine environment), if no particular aggressive conditions exist. Such particular aggressive conditions are e.g. permanent, alternating immersion in seawater or the splash zone of seawater, chloride atmosphere of indoor swimming pools or atmosphere with extreme chemical pollution (e.g. in desulphurisation plants or road tunnels where de-icing materials are used).

The provisions made in this European Technical Approval are based on an assumed working life of the anchor of 50 years. The indications given on the working life cannot be interpreted as a guarantee given by the producer, but are to be regarded only as a means for choosing the right products in relation to the expected economically reasonable working life of the works.

⁷ For façade slabs made of basalt the density shall be at least 2.7 kg/dm³ and for basaltlava at least 2.2 kg/dm³; damaging ingredients (see Sonnenbrennerbasalt) may not exist.

⁸ For façade slabs made of sandstone the density shall be at least 2.1 kg/dm³.

⁹ For façade slabs made of natural stones with planes of anisotropy, the difference between the bending strengths determined parallel to the planes of anisotropy and perpendicular to the edges of the planes of anisotropy shall not be more than 50 %.

2 Characteristics of the product and method of verification

2.1 Characteristics of the product

The anchor corresponds to the drawings and specifications given in Annex 2. The characteristic material values, dimensions and tolerances of the anchor not indicated in Annex 2 shall correspond to the respective values laid down in the technical documentation¹⁰ of this European technical approval.

The anchor is considered to satisfy the requirements for performance class A1 of the characteristic reaction to fire, in accordance with the provisions of EC decision 96/603/EC (as amended) without the need for testing on the basis of its listing in that decision.

In addition to the specific clauses relating to dangerous substances contained in this European Technical Approval, there may be other requirements applicable to the products falling within its scope (e.g. transposed European legislation and national laws, regulations and administrative provisions). In order to meet the provisions of the Construction Products Directive, these requirements need also to be complied with, when and where they apply.

The characteristic values for the design of the façade slabs with rear fixing by the anchor are given in Annex 5.

Every anchor is marked with the identifying mark of the producer and the anchor size according to Annex 2.

The anchor shall be packed and delivered as fixing unit (cone bolt, expansion part and sleeve). The nut may be packed and delivered separately.

2.2 Methods of verification

The assessment of fitness of the anchor for the intended use in relation to the requirement for safety in use in the sense of the essential requirement N°4 of Council Directive 89/106/EEC has been made based on the following tests carried out:

- (1) Axial tension tests
- (2) Shear tests
- (3) Tests with combined tension and shear loading
- (4) Tests on structural members
- (5) Tests on functioning under repeated loads
- (6) Tests on functioning under sustained loads
- (7) Tests on functioning under freeze/thaw conditions (25 freeze/thaw cycles)
- (8) Tests on functioning after immersion in water.

¹⁰ The technical documentation comprises all information necessary for the production, installation and maintenance of the anchor; these are in particular the design drawings and the installation instructions. The part to be treated confidentially is deposited with Deutsches Institut für Bautechnik and, as far as this is relevant to the tasks of the approved bodies involved in the procedure of attestation of conformity, shall only be handed over to the approved body.

3 Evaluation and attestation of conformity and CE marking

3.1 System of attestation of conformity

According to the communication of the European Commission¹¹ the system 2 (ii)-1 (referred to as System 2+) of attestation of conformity applies.

These systems of attestation of conformity are defined as follows:

System 2+: Declaration of conformity of the product by the manufacturer on the basis of:

- (a) Tasks for the manufacturer:
 - (1) initial type-testing of the product;
 - (2) factory production control;
 - (3) testing of samples taken at the factory in accordance with a prescribed test plan.
- (b) Tasks for the approved body:
 - (4) certification of factory production control on the basis of:
 - initial inspection of factory and of factory production control;
 - continuous surveillance, assessment and approval of factory production control.

3.2 Responsibilities

3.2.1 Tasks for the manufacturer

3.2.1.1 Factory production control

The manufacturer shall exercise permanent internal control of production. All the elements, requirements and provisions adopted by the manufacturer shall be documented in a systematic manner in the form of written policies and procedures, including records of results performed. This production control system shall insure that the product is in conformity with this European Technical Approval.

The manufacturer may only use initial materials and components stated in the technical documentation of this European Technical Approval.

The factory production control shall be in accordance with the control plan¹² which is part of the technical documentation of this European Technical Approval. The control plan is laid down in the context of the factory production control system operated by the manufacturer and deposited with Deutsches Institut für Bautechnik.

The results of factory production control shall be recorded and evaluated in accordance with the provisions of the control plan.

3.2.1.2 Other tasks for the manufacturer

The manufacturer shall, on the basis of a contract, involve a body which is approved for the tasks referred to in section 3.1 in the field of "anchors" in order to undertake the actions laid down in section 3.3. For this purpose, the control plan referred to in sections 3.2.1.1 and 3.2.2 shall be handed over by the manufacturer to the approved body involved.

The manufacturer shall make a declaration of conformity, stating that the construction product is in conformity with the provisions of this European Technical Approval.

¹¹ Letter of the European Commission of 22/07/2002 to EOTA

¹² The control plan is a confidential part of the European technical approval and only handed over to the approved body involved in the procedure of attestation of conformity. See section 3.2.2.

3.2.2 Tasks of approved bodies

The approved body shall perform the following tasks in accordance with the provisions laid down in the control plan:

- initial inspection of factory and of factory production control,
- continuous surveillance, assessment and approval of factory production control.

The approved body shall retain the essential points of its actions referred to above and state the results obtained and conclusions drawn in a written report.

The approved certification body involved by the manufacturer shall issue an EC certificate of conformity of the factory production control stating the conformity with the provisions of this European Technical Approval.

In cases where the provisions of the European Technical Approval and its control plan are no longer fulfilled the certification body shall withdraw the certificate of conformity and inform Deutsches Institut für Bautechnik without delay.

3.3 CE marking

The CE marking shall be affixed on the packaging or accompanying commercial document, e.g. the EC declaration of conformity. The letters "CE" shall be followed by the identification number of the approved certification body, where relevant, and be accompanied by the following additional information:

- the name and address of the producer (legal entity responsible for the manufacture),
- the last two digits of the year in which the CE marking was affixed,
- the number of the EC certificate for the factory production control,
- the number of the European technical approval,
- use category (25 freeze/thaw cycles),
- size.

4 Assumptions under which the fitness of the product for the intended use was favourably assessed

4.1 Manufacture

The European Technical Approval is issued for the product on the basis of agreed data/information, deposited with Deutsches Institut für Bautechnik, which identifies the product that has been assessed and judged. Changes to the product or production process, which could result in this deposited data/information being incorrect, should be notified to Deutsches Institut für Bautechnik before the changes are introduced. Deutsches Institut für Bautechnik will decide whether or not such changes affect the ETA and consequently the validity of the CE marking on the basis of the ETA and if so whether further assessment or alterations to the ETA shall be necessary.

4.2 Installation

4.2.1 Design of the fixings

The fitness of the anchor for the intended use is given under the following conditions:

- The façade slabs correspond to EN 1469:2004 and to the indications given in the annexes; the characteristic values of material of the façade slabs are determined and declared according to Annex 10;
- As a rule each façade slab is fixed with four anchors in rectangular arrangement to the substructure and stand-off fixing anchors are used (see Annex 1); the characteristic values of the anchor, the edge distances and spacing, as well as the characteristic values of the slabs according to Annex 5 are observed.
- The façade slabs neither are used to transmit impact loads nor for guard rail.
- The substructure is constructed such that the façade slabs are fixed technically restrain-free via three sliding bearings and one fixed bearing (see Annex 7). Two fixing points of the façade slab are designed such that they are able to carry the dead load of the façade slab. When using agraffes on horizontal load-bearing profiles the fixing points of a façade slab situated horizontally at the same height are fastened in each case to the same load-bearing profile.
- As a rule reveal slabs are fastened to the façade slab with two angle supports according to Annex 8 and flush fixing anchors are used (see Annex 1); it is ensured that the reveal angles are resting against the slabs; when using reveal angles with elongated holes a defined load transmission (e.g. clutch disc or interlocking of the washer to the surface of the angle) in the direction of the elongated hole is ensured; the edge distances according to Annex 5 are not fallen below; the minimum spacing between the anchors of the façade slab and the anchors of the reveal angles resting in the façade slabs amounts to more than $8 \times h_v$ (h_v = anchorage depth of the anchor).
- Joint constructions between the façade slabs are done by a joint profile, permanently elastic filler or are kept open; it is ensured that additional stresses (e.g. by temperature) do not lead to important additional loadings.
- The façade and reveal slabs, their fixings as well as the substructure including its connection to wall brackets and their connection to the construction works are designed under the responsibility of an engineer skilled in the field of façade construction taking account the load effects (dead load, wind load) for the respective case of application; the stiffness of the substructure will be considered for the respective case of application; the loading of the reveal angles in the case of service load will be verified by calculation; taking account of the loads to be fixed checkable calculations and construction drawings are prepared; the position of the anchor is given in the construction drawings.
- When using horizontal load-bearing profiles the following shall be verified:
 - The agraffes do not prop on the façade panel due to torsion of the horizontal load-bearing profile and twisting of the façade panel.
 - The total of the angle α results from torsion of the horizontal load-bearing profile and twisting of the façade panel at the fixing point does not exceed the value $\alpha = 2^\circ$.
- Design of the anchor and the façade and reveal slabs is carried out according to the design method according to Annexes 12 to 19.
- For the internal thread anchor using only fastening screws of sizes M6 made of stainless steel 1.4401 or 1.4571 EN ISO 10088-3 with a minimum strength class 70 EN ISO 3506-1 ($f_{uk} = 700 \text{ N/mm}^2$; $f_{yk} = 450 \text{ N/mm}^2$). The thread engagement length of the fastening screw is at least 6 mm and maximum 10 mm.

4.2.2 Installation of the anchors

The fitness for use of the anchor can be assumed only, if the following installation conditions are observed:

- Installation by appropriately qualified personnel under the supervision of the project supervisor
- Installation only as delivered by the manufacturer without exchanging the individual parts.
- Installation according to manufacturer's specifications and construction drawings using the tools indicated in the installation instructions.
- Making of the undercut drilling is done with the drill bit according to Annex 3 and a special drilling device in accordance with the information deposited with Deutsches Institut für Bautechnik.
- The drillings are done at the factory or on site under workshop conditions; when making the drillings on site the execution is supervised by the responsible project supervisor or a skilled representative of the project supervisor.
- The drillings are removed from the drill hole; the nominal diameter of the drill corresponds to the values of Annex 3; in case of aborted drill hole a new drilling at a minimum spacing of at least twice the depth of the aborted drill hole is arranged.
- The geometry of the drill hole is checked on 1 % of all drillings. The following dimensions shall be checked and documented according to manufacturer's information and testing instructions by means of a measuring device according to Annex 4:
 - Diameter of the cylindrical drill hole
 - Diameter of the undercut (gauges according to Annex 4)
 - Remaining wall thickness (drill hole depth and panel thickness respectively)

If the tolerances given in Annex 3 are exceeded, the geometry of the drill hole shall be checked on 25 % of the drillings performed. No further drill hole may exceed the tolerances otherwise all the drill holes shall be controlled. Drilling holes falling below or exceeding the tolerances shall be rejected.

Note: Checking the geometry of the drill hole on 1 % of all drillings means that on one of the 25 slabs (this corresponds to 100 drillings) one drilling shall be checked. If the tolerances given in Annex 3 are exceeded the extent of the control shall be increased to 25 % of the drillings, i.e. one drilling each shall be checked on all the 25 slabs.

- The installation of the anchor is performed with a torque wrench only or with a drive-in device specifically for this purpose and a setting device respectively (see Annex 4)
- At flush fixing the sleeve is flush at set state with the back of the panel or shows, at stand-off fixing, a projection according to Annex 7.
- The positive fit of the anchor in the drill hole is checked as follows:
 - Flush fixing anchor → visual inspection; the sleeve shall lock up flush with the back of the façade panel
→ Measuring the projection of the bolt
 - Stand-off fixing anchor → Measuring the projection of the bolt
- During transport and storage on site the façade slabs are protected from damages; the façade slabs are not to be hung up jerkily (if need be lifters shall be used for hanging up the façade slabs); façade slabs and reveal slabs respectively with incipient cracks are not to be installed.
- The façade are installed by skilled specialists and the laying instructions of the manufacturer shall be paid attention to.

5 Indications to the manufacturer

It is the responsibility of the manufacturer to ensure that the information on the specific conditions according to 1 and 2 including Annexes referred to and 4.2.1 and 4.2.2 is given to those who are concerned. This information may be made by reproduction of the respective parts of the European Technical Approval. In addition all installation data shall be shown clearly on the package and/or on an enclosed instruction sheet, preferably using illustrate on(s).

The minimum data required are:

- maximum possible setting depth;
- diameter of the thread;
- diameter of the cylindrical drilling;
- free thread length after setting anchor (anchor with external thread) or minimum and maximum thread engagement length (anchor with internal thread) respectively.

All data shall be presented in a clear and explicit form.

Georg Feistel
Head of Department

beglaubigt:
Scheller

I Product and intended use

Table 1: Types of anchors

	Anchor with external thread		Anchor with internal thread
Anchor with steel sleeve			
Anchor with carbon sleeve			

Table 2: Types of mounting / System of designation

Flush fixing	Stand-off fixing
with steel sleeve	
<p>example: FZP II 13x15 M8/15 A4 — Sleeve material — Bolt projection length b — Thread diameter — Installed anchor length a — Cylindrical drill hole \varnothing c Fischer Zykon Panel anchor II drill hole geometry: cylindrical conical</p>	<p>example: FZP II 13x24 M8/SO/14 AL — Hexagonal nut material — Bolt projection length b — Stand-off — Thread diameter — Installed anchor length a — Cylindrical drill hole \varnothing c Fischer Zykon Panel anchor II drill hole geometry: cylindrical conical</p>
with carbon sleeve	
<p>example: FZP II 13x15 M8/15 CARBON</p>	<p>example: FZP II 13x24 M8/SO/14 CARBON</p>

fischer-Zykon-panel anchor FZP II

Product and built-in state

Annex 1

of European technical approval

ETA-11/0145

Cone bolt

External thread M6 or M8

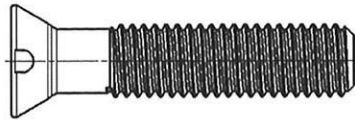

drive optional,
e.g.: slot,
hexagon socket,
external hexagon

Internal thread M6

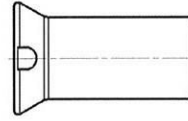

Expansion part

For cone bolt with external thread M6 or M8, for cone bolt with internal thread M6, for Stone group I to IV (see section 1.2, Table 1)



Sleeve

For cone bolt with external thread M6 or M8

Stainless steel
(flush / stand-off fixing)

Carbon
(flush fixing)

Carbon
(stand-off fixing)

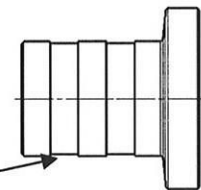
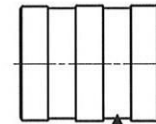

Type name e.g.:  FZP M6

Hexagonal Nut / hexagonal nut ES

For cone bolt with external thread M6 or M8, optional for stand-off fixing



Marking: Stainless steel = A4
Aluminum = Al

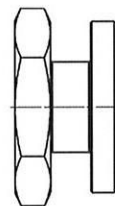

Table 3: Material parts of anchor

Part of anchor	Material
Cone bolt	Stainless steel, DIN EN 10 088 - 1.4401 or 1.4571
Expansion part	Stainless steel, DIN EN 10 088 - 1.4401 or 1.4571
Sleeve	Stainless steel, DIN EN 10 088 - 1.4401 or 1.4571 or Polyamid 6.6 CARBON
Hexagonal nut	Stainless steel, DIN EN 10 088 - 1.4401 or 1.4571 or Aluminium, DIN EN 755 - 3.1645
Hexagonal nut ES	Aluminium, DIN EN 755 - 3.1645

fischer-Zykon-panel anchor FZP II

Parts of anchor

Annex 2

**of European
technical approval**

ETA-11/0145

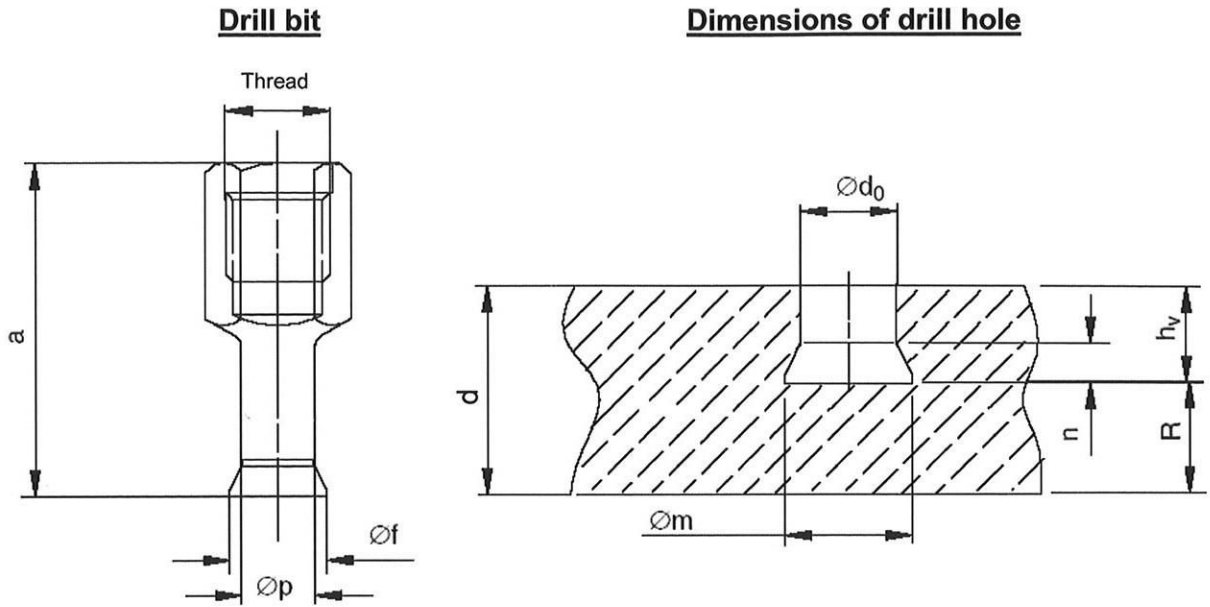

Table 4: Drill bit assignment and dimensions [mm] of drill bit and drill hole

Drill bits ¹⁾				
Type	Thread	a	Ø p	Ø f
FZPB 9	M14	45	5,8	9
FZPB 11	M14	45	7,8	11
FZPB 13	M14	45	9,8	13

Drill hole						
Drill bit ¹⁾	Ø d ₀ ²⁾	Ø m ²⁾	FZP II	n	h _v ³⁾	R ⁴⁾
FZPB 9	11 ^{+0,4} _{-0,2}	13,5 ±0,3	M6	≈ 4	12 ≤ h _v ≤ 25	≥ 0,4 d
FZPB 11						
FZPB 11	13 ^{+0,4} _{-0,2}	15,5 ±0,3	M8	≈ 4	12 ≤ h _v ≤ 25	≥ 0,4 d
FZPB 13						

1) Drill bit for different drill methods respectively drilling machine

2) Measurements can be attributive proved by diameter or volume gauge (see Annex 4)

3) Tolerances flush fixing: h_v^{+0,4}_{-0,1}

4) Only for stand-off fixing

fischer-Zykon-panel anchor FZP II

Drill bit and geometry of the drill hole

Annex 3

**of European
technical approval**

ETA-11/0145

Settings tools for the installation of the anchor

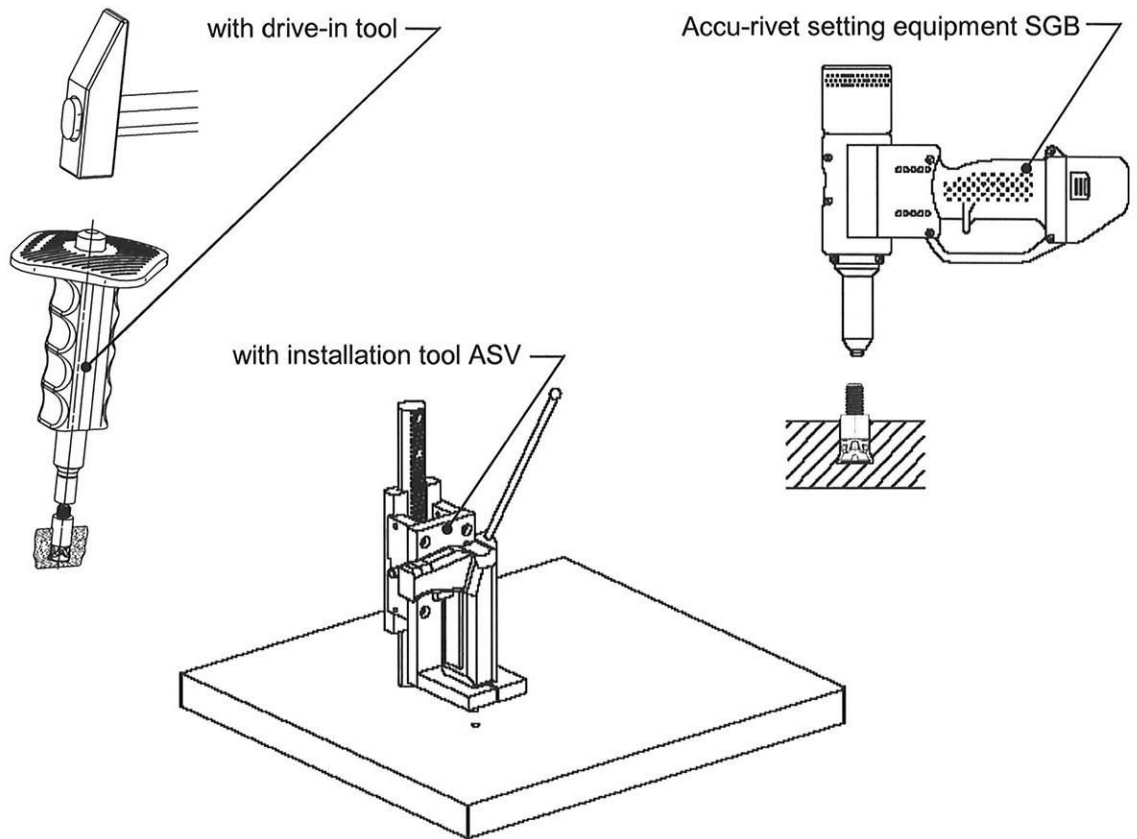

Testing equipment for undercut control

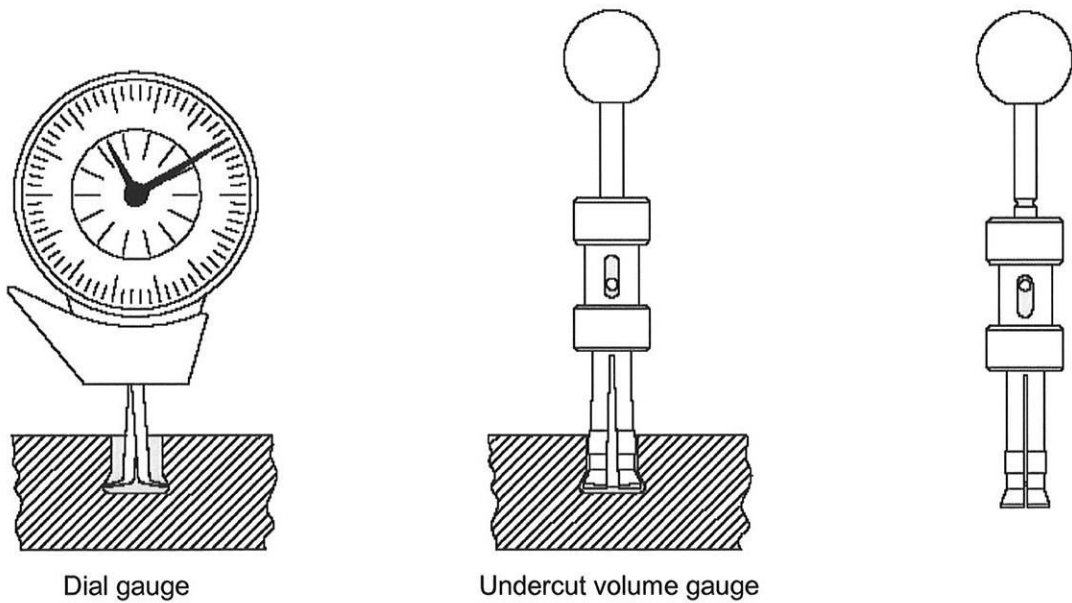

fischer-Zykon-panel anchor FZP II

Setting tools and testing equipment

Annex 4

of European
technical approval

ETA-11/0145

Table 5: Characteristic values of anchors and façade and reveal panels made of natural stones ¹⁾

Façade panel				
panel thickness ²⁾	d [mm]		20(30) ≤ d ≤ 70	
maximum size of panel	A ≤ [m ²]		3,0	
maximum side length	H or L ≤ [m]		3,0	
number of anchors (rectangular arrangement)			4	
edge distance ³⁾	D _L or D _H		50 mm ≤ D _L or D _H ≤ 0,25L or 0,25H	
spacing ³⁾	a _L or a _H ≥ [mm]		8 h _v	
Reveal panel				
panel thickness ²⁾	d = [mm]		20(30) ≤ d ≤ 70	
edge distance ³⁾	b _{rL} or b _{rH}		40 mm ≤ b _{rL} or b _{rH} = 0,2H or 0,2L	
anchor				
anchorage depth ⁴⁾	h _v [mm]		12 ≤ h _v ≤ 25 ⁴⁾	
nominal diameter of drill hole	M6	∅ d ₀ = [mm]	11	
	M8	∅ d ₀ = [mm]	13	
remaining wall thickness ⁵⁾	R ≥ [mm]		0,4 d	
Characteristic load-bearing capacity – façade slab (anchor load-bearing capacity, bending strength)				
tension load	N _{Rk} = [kN]		see Annex 6 (depending on material, chosen slab thickness, anchorage depth and relative edge distance)	
shear load	V _{Rk} = [kN]			
bending stress	σ _{Rk} = [N/mm ²]		see Annex 6 (depending on material)	
partial safety factor ⁶⁾	γ _M = [-]		see Annex 6 (depending on material)	
Characteristic load-bearing capacity - anchor (steel failure)				
		FZP M6	FZP M8	FZP-I M6 ⁷⁾
tension load	N _{Rk,s} = [kN]	15,1	27,5	14,1
partial safety factor ⁶⁾	γ _{Ms} = [-]	1,5	1,5	1,87
shear load	V _{Rk,s} = [kN]	7,5	13,7	7,0
partial safety factor ⁶⁾	γ _{Ms} = [-]	1,25	1,25	1,56

1) selected natural stones according to section 1.2

2) for sandstone, limestone and basaltlava: panel thickness d ≥ 30 mm

3) for small fitted pieces, differential or fill-in pieces the minimum edge distance or spacing shall be chosen constructively; by structural design by means of FE program bigger edge distances are possible

4) h_v in 1 mm steps only (12, 13, 14 mm ... 25 mm) – tolerances see Annex 3, Table 4, footnote 3)

5) only for stand-off fixing

6) recommended partial safety factor in absence of other national regulations

7) only for fastening screws made of stainless steel 1.4401 or 1.4571 EN ISO 10088-3 with a minimum strength class 70 EN ISO 3506-1 (f_{uk} = 700 N/mm²; f_{yk} = 450 N/mm²)

fischer-Zykon-panel anchor FZP II

Characteristic values of anchors and panels

Annex 5

**of European
technical approval**

ETA-11/0145

Characteristic load-bearing capacity - façade slab (anchor load-bearing capacity, bending strength)

Characteristic anchor load-bearing capacity N_{Rk} and V_{Rk}

Depending on the respective natural stone, the slab thickness, setting depth and edge distance of the anchor the characteristic load-bearing capacity N_{Rk} (tension load) and V_{Rk} (shear load) result as follows:

$$N_{Rk} = N_{u5\%} \cdot \alpha_{exp}$$

$$V_{Rk} = V_{u5\%} \cdot \alpha_{exp}$$

Characteristic value of bending strength σ_{Rk}

Depending on the respective natural stone the characteristic value of bending strength results as follows:

$$\sigma_{Rk} = \sigma_{u5\%} \cdot \alpha_{exp}$$

Exposition factor α_{exp}

Depending on the respective natural stone for consideration of deterioration of strength due to weathering (freeze-thaw-stress, moisture penetration) the following factor shall be determined:

$$\alpha_{exp} = 1.25 \cdot \sigma_{Rum,exp} / \sigma_{Rum} \leq 1.0 \quad \text{(simplified, for natural stones of stone group I and II, it can be assumed that the exposition factor is } \alpha_{exp} = 0.8 \text{)}$$

Partial safety factor γ_M

In absence of other national regulations the following partial safety factor for façade material is recommended:

$$\gamma_M = 1.8 \cdot \gamma_1 \cdot \gamma_2$$

Characteristic value of material depending on the respective natural stone

- $N_{u5\%}$ = lower expectation value of breaking load at anchor for tension load, depending on slab thickness, setting depth and edge distance of the anchor (according to Annex 10)
- $V_{u5\%}$ = lower expectation value of breaking load at anchor for shear load, depending on slab thickness, setting depth and edge distance of the anchor (according to Annex 10)
- $\sigma_{u5\%}$ = lower expectation value of bending strength (according to Annex 10)
- σ_{um} = average value of bending strength (according to Annex 10)
- $\sigma_{um,exp}$ = average value of bending strength after weathering (according to Annex 10)
- γ_1 = 1.25 if the tests for determination of $N_{u5\%}$, $V_{u5\%}$ and $\sigma_{u5\%}$ date back more than 2 years ¹⁾
= 1.0 if the tests for determination of $N_{u5\%}$, $V_{u5\%}$ and $\sigma_{u5\%}$ date back less than 2 years ¹⁾
- γ_2 = $1 + (v[\%] - 15) \cdot 0.03 \geq 1.0$ with v = coefficient of variation determined from the declared values of standard deviation and average value

1) Due to the alterability of natural stone the actual strength values of the material installed may deviate from the declared values. The partial safety factor γ_1 considers at which date the characteristic values of the material have been determined.

fischer-Zykon-panel anchor FZP II	Annex 6
Characteristic load-bearing capacity of specific natural stones	of European technical approval ETA-11/0145

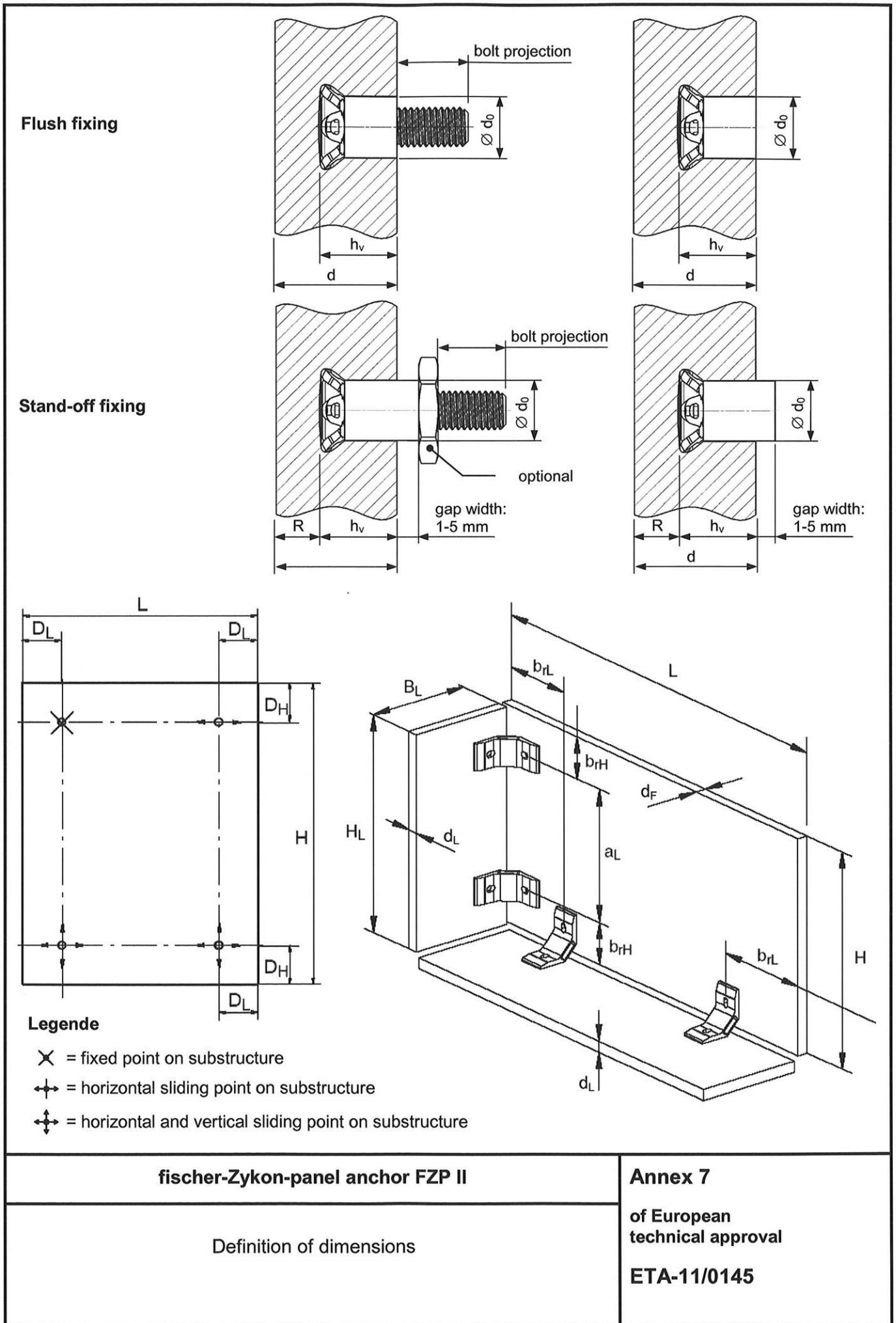
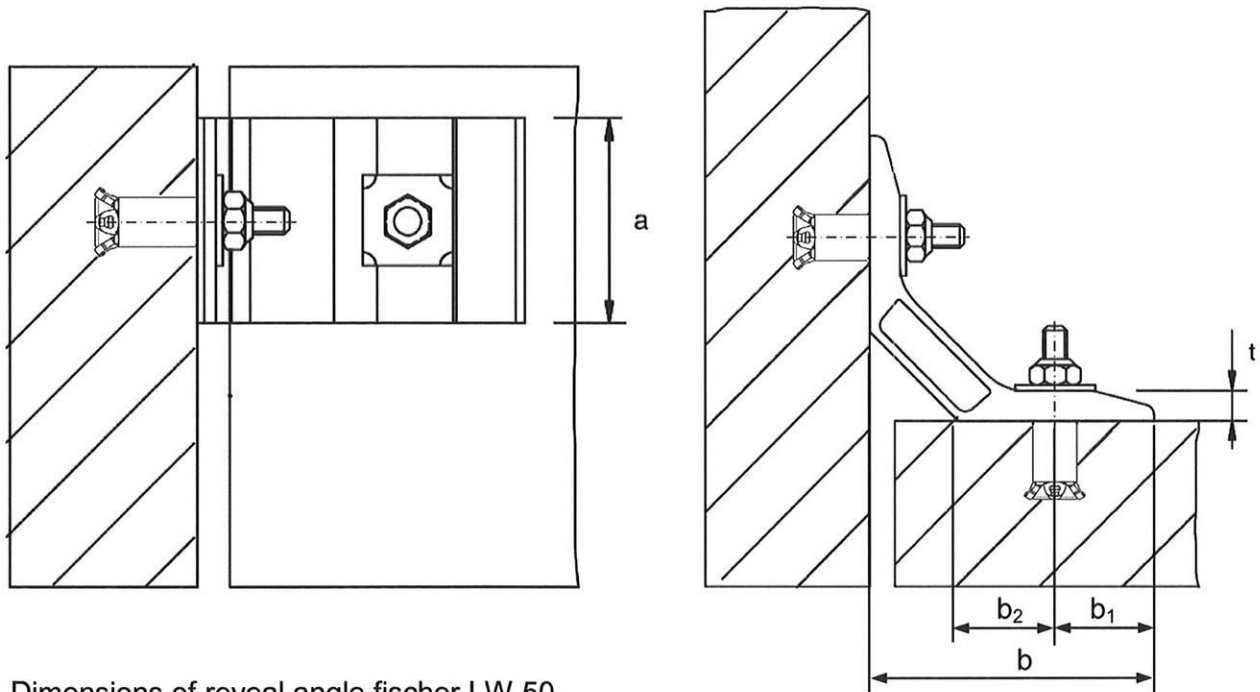

Table 6: Characteristic values of the reveal angles

		stainless steel 1.4401 or 1.457 EN 10 088-3	aluminium EN 755-1
angle thickness	t [mm]	$t \geq 4$	$t \geq 5$
angle width	a [mm]	$40 \leq a \leq 100$	$40 \leq a \leq 100$
angle length	b [mm]	$65 \leq b \leq 20 t$	$65 \leq b \leq 16 t$
Distance between the centre of anchor to outer edge of reveal angle	b_1 [mm]	$25 \leq b_1 \leq 10 t$	$25 \leq b_1 \leq 8 t$
Distance between the centre of anchor to inner edge of reveal angle	b_2 [mm]	$40 \leq b_2 \leq 10 t$	$40 \leq b_2 \leq 8 t$
cross tension stiffness	c_q [MN/m]	$c_q \leq 2.5$ ¹⁾	

1) see Annex 13 - 2.2 Determination of the anchor loads on the fixing points of reveal angle

Denominations of dimensions of reveal angles on the example fischer LW 50 reveal angle



Dimensions of reveal angle fischer LW 50

- t = 8 mm
- a = 50 mm
- b = 80 mm
- b₁ = 30 mm
- b₂ = 25 mm

fischer-Zykon-panel anchor FZP II

Reveal angle

Annex 8

**of European
technical approval**

ETA-11/0145

Example of a substructure

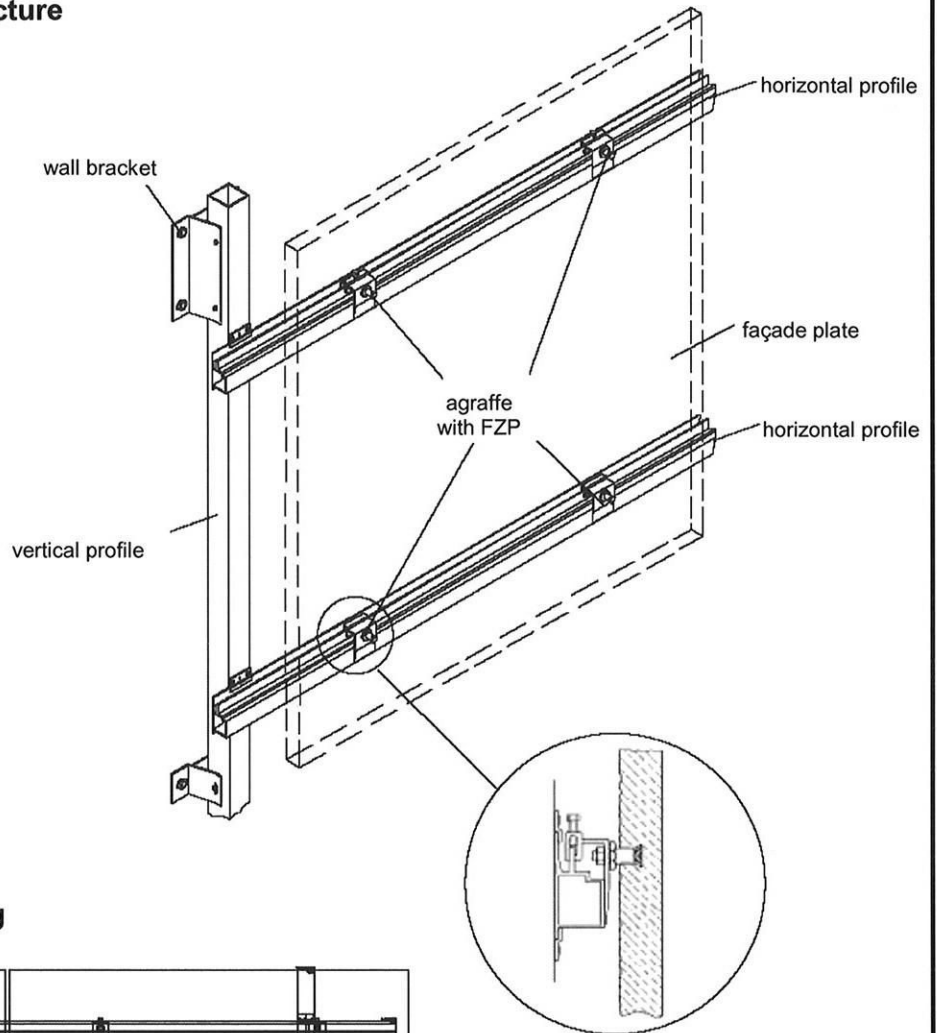

Example of a typical bearing

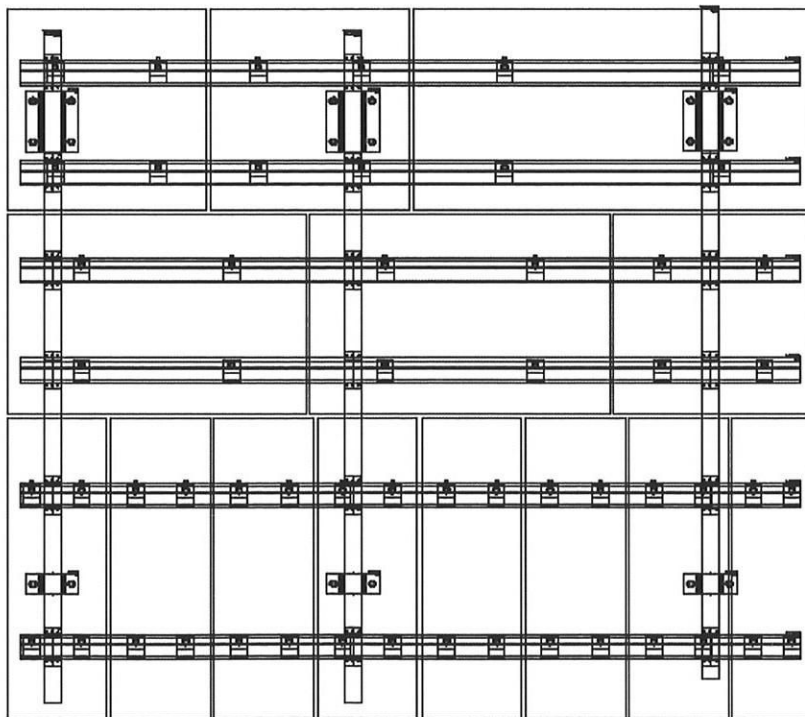

fischer-Zykon-panel anchor FZP II

Example of substructure and fixing of the panel

Annex 9

**of European
technical approval**

ETA-11/0145

II Determination of the characteristic values of material

1. General

Natural stones for cladding slabs are harmonised by EN 1469. Hence the natural stone slabs shall be classified according to EN 1469 and shall show the CE-marking.

2. Determination of the characteristic values of material ¹⁾

2.1 bending strength ($\sigma_{u5\%}$, σ_{um})

According to EN 1469 the bending strength shall be determined from tests according to EN 12372 or EN 13161²⁾. From the test results the lower expectation value $\sigma_{5\%}$ ³⁾, the average value σ_{um} and the standard deviation shall be determined.

2.2 Breaking load of the anchor ($N_{u5\%}$, $V_{u5\%}$)

The breaking load of the anchor due to tension load and shear load⁴⁾ shall be determined by tests. Under consideration of the slab thickness, setting depth and edge distance of the anchor the tests according to Annex 11, Table 7 shall be performed. From the test results the lower expectation value $N_{u5\%}$ or $V_{u5\%}$ ³⁾ respectively, the average value N_{um} or V_{um} respectively and the standard deviation shall be determined with respect to the slab thickness, the setting depth and edge distance of the anchor.

2.3 Bending strength after weathering ($\sigma_{um,exp}$)

The bending strength after weathering $\sigma_{um,exp}$ shall be determined as follow:

$$\sigma_{um,exp} = \sigma_{um,A} \text{ Or } \sigma_{um,exp} = \min(\sigma_{um,B}, \sigma_{um,C})$$

$\sigma_{um,A}$ = average value of bending strength after Freeze-thaw-cycle tests according to DIN 52008:2006-07, Annex C determined on wet samples, which have been previously immersed in water for 2h to 3h

$\sigma_{um,B}$ = average value of bending strength after Freeze-thaw-cycle tests according to EN 12371

$\sigma_{um,C}$ = average value of bending strength determined on wet samples, which have been previously immersed in water for 2h to 3h

The bending strength after weathering ($\sigma_{um,exp}$) shall be determined from tests according to EN 12372 or EN 13161²⁾. The samples for determination of the bending strength without weathering (σ_{um}) and after weathering ($\sigma_{um,exp}$) shall be made from one and the same charge.

Notes:

- 1) For natural stones with planes of anisotropy the position of the planes of anisotropy shall be considered (see Figure 1 to Figure 3)

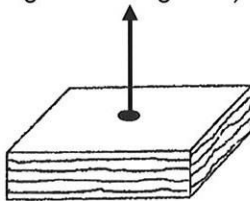

Figure 1: Type I

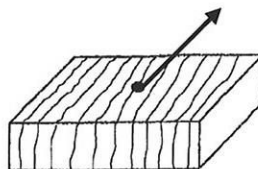

Figure 2: Type IIa

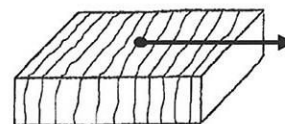

Figure 3: Type IIb

- 2) For evaluation and comparison of bending strengths (e.g. after freeze-thaw-cycles or for the proof of the stability) the tests shall always performed with the same test methods and the same dimensions of the test members
- 3) 5%-Fractile, confidence level of 75%, unknown standard deviation and lognormal distribution
- 4) For anchors in stand-off fixing or with distance washer, the shear tests shall be performed with the maximum possible distance

fischer-Zykon-panel anchor FZP II

Determination of the characteristic values of material

Annex 10

**of European
technical approval**

ETA-11/0145

Table 7: Tests on anchors fixed in slab sections

	slab thickness ³⁾	anchorage depth ⁴⁾	edge distance		dimension of test member		diameter of support	number of tests		
	d	h _v	D _H	D _L	H	L	∅ _s	n		
	[mm]	[mm]	[mm]		[mm]		[mm]	[-]		
tension load ¹⁾	20(30) ≤ d ≤ 70	12 ≤ h _v ≤ 25	100	100	200	200	135	10		
			50	100						
			50	50						
shear load ^{1), 2)}			100	100	200	400			-	10
			50	100						
			50	50						

- 1) test sketches see Figure 4 to Figure 6
- 2) the anchors are to be tested with the maximum possible distance (stand-off fixing)
- 3) for sandstone and limestone: slab thickness d ≥ 30 mm
- 4) h_v in 1 mm steps (12, 13, 14 mm, ... 25 mm)

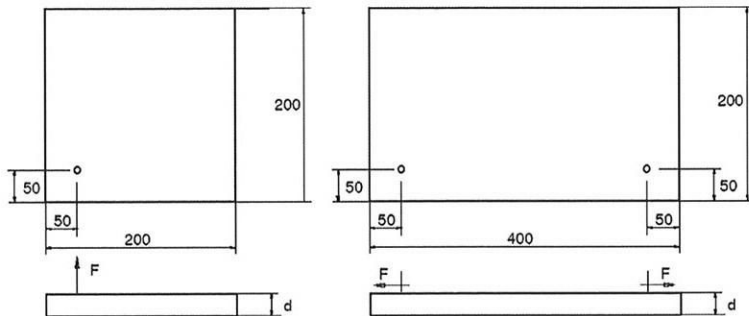

Figure 4: tension test or shear test for an edge distance 50 / 50 mm

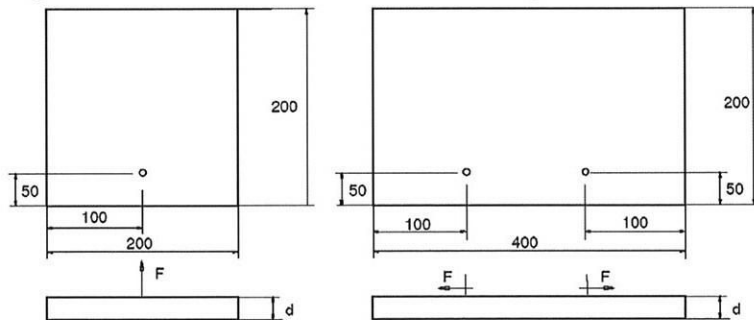

Figure 5: tension test or shear test for an edge distance 50 / 100 mm

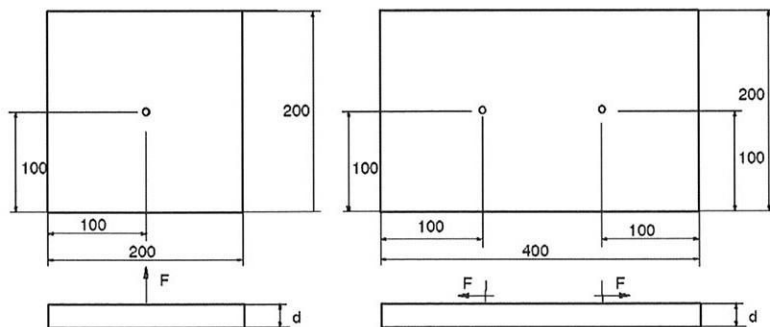

Figure 6: tension test or shear test for an edge distance 100 / 100 mm

fischer-Zykon-panel anchor FZP II

Determination of the characteristic values of material

Annex 11

of European technical approval

ETA-11/0145

III Design method

1 General

1.1 System assumptions

It shall be distinguished between an uniform and a non-uniform bearing.

The geometrical symmetrical execution signifies for example the configuration analogous to Annex 9. If additional to the geometrical symmetrical execution the uniform horizontal or vertical profiles are used, it can be proceeded from a uniform bearing.

In principle an uniform bearing is present if at least one of the cases applies according to Table 8.

If none of the cases listed in Table 8 applies, it shall be proceeded from a non-uniform bearing, unless proven that the redistribution of the anchor forces falls below the limit value of 15 %.

Table 8: Criteria for uniform bearing

Case 1	$C_1 = C_3$ and $C_2 = C_4$
Case 2	$C_1 = C_2$ and $C_3 = C_4$
C_i = spring stiffness of the substructure (see Figure 7)	

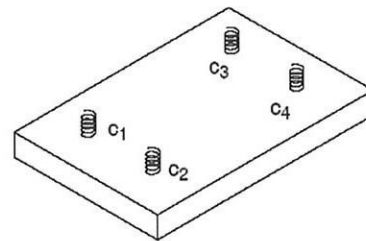

Figure 7: structural model of bearing

1.2 Safety concept

The design values of the actions shall be calculated on basis of EN 1990 in consideration of the existing loads. The combinations of actions shall be equal to EN 1990. The actions shall be specified according to EN 1991-1-1 to EN 1991-1-7. Corresponding national regulations shall be taking into consideration. The unfavourable combination is decisive. Where necessary for the design of the anchor and the façade panel several combinations shall be analysed separately.

The typical fundamental combination for façade panels considers actions from dead load $F_{Sk,G}$ (permanent action), wind $F_{Sk,w}$ (leading variable action) and from mounting restraint $F_{Sk,Zw}$ (permanent load towards the anchor axis).

According to EN 1990 the following fundamental combination depending on the load direction results for a vertical façade panel:

Fundamental combination for loads parallel to the panel:

$$F_{Sd||} = F_{Sk,G} \cdot \gamma_G$$

Fundamental combination for loads perpendicular to the panel:

$$F_{Sd\perp} = F_{Sk,w} \cdot \gamma_Q + F_{Sk,Zw} \cdot \gamma_G$$

$$\text{with } \gamma_G = 1.35; \gamma_Q = 1.50$$

For hanging panels (over head mounting) or reveals respectively the load direction shall be take into consideration and the combinations of actions shall be based on EN 1990.

For mounting restraint a load of $F_{Sk,Zw} = 0.1$ kN shall be applied. National regulations shall be take into consideration.

The design values of the actions shall be compared with the design values of the resistance. The regulations according to Section 2.3 and 3.4 shall be observed.

fischer-Zykon-panel anchor FZP II

Design method

Annex 12

**of European
technical approval**

ETA-11/0145

2 Anchor design

2.1 Determination of the anchor loads at the fixing points of the façade panel

The determination of the anchor loads depends on the bearing mode of the façade panel. The anchor loads are to be determined for each fixing point from the load proportions wind and dead load¹ of the façade panel as well as from the load proportions wind and dead load of the reveal panel.

In case of uniform bearing for determination of the anchor loads is to be proceeded from a 4-point-fixing with two load-bearing anchors for the dead load. Additionally for a load-bearing anchor a mounting restraint load of $F_{Sk,Zw} = 0.1$ kN as tensile load shall be taken into account.

In case of a non-uniform bearing for determination of the anchor loads is to be proceeded from a 3-point-fixing with two load-bearing anchors.

2.2 Determination of the anchor loads on the fixing points of reveal angle

The anchor loads at the reveal angle are to be determined from the load proportions wind and dead load of the reveal panel.

Additionally the load proportion from strain caused by a temperature difference of ± 35 K between the façade panel and the reveal panel shall be taken into account. Unless the cross tension stiffness of the reveal angle will be verified for the verification of the temperature load it may be simplified proceeded from a cross tension stiffness $c_q = 1,2$ MN/m, if the limit dimension of the angle size is observed according to Table 9:

Table 9: Limit dimension of the angle dimensions

		stainless steel	aluminium
angle thickness	t [mm]	≤ 6	≤ 8.5
angle width	a [mm]	≤ 80	≤ 80

Note:

If the anchors are installed with an edge distance $40 \text{ mm} \leq a_r < 50 \text{ mm}$, the characteristic load-bearing capacity for tension load shall be reduced by the factor 0.9.

¹ The dead load of the façade and reveal plates for relevant material is to be determined from the density according to EN 1936 taking into account the water absorption under atmospheric pressure according to EN 13755.

fischer-Zykon-panel anchor FZP II	Annex 13 of European technical approval ETA-11/0145
Design method	

2.3 Verification of the anchor loads

For the determined anchor forces (sections 2.1 and 2.2) it is verified, that equations (1) and (2) are observed. In case of coincident stress of an anchor due to tension and shear load equation (3) shall be observed additionally:

tension load / compression load:
$$\frac{N_{Sd}}{N_{Rd}} \leq 1.0 \tag{1}$$

shear load:
$$\frac{V_{Sd}}{V_{Rd}} \leq 1.0 \tag{2}$$

interaction diagonal tension force:
$$\frac{N_{Sd}}{N_{Rd}} + \frac{V_{Sd}}{V_{Rd}} \leq 1.2 \tag{3}$$

mit: N_{Sd} = design value of existing anchor tension load / compression load

V_{Sd} = design value of existing anchor shear load

N_{Rd} = design value of anchor load-bearing capacity

for tension load ²: $N_{Rd} = N_{Rk} / \gamma_M$

for compression load: $N_{Rd} = -k \cdot N_{Rk} / \gamma_M$

with: N_{Rk} according to Annex 5, Table 5

γ_M according to Annex 5, Table 5

$k = 0.8$ for $0.4d \leq R \leq h_v$

or

1.0 for $R > h_v$

V_{Rd} = design value of anchor load-bearing capacity

for shear load: $V_{Rd} = V_{Rk} / \gamma_M$

with: V_{Rk} according to Annex 5, Table 5

γ_M according to Annex 5, Table 5

² Special case reveal panel: If the anchors are installed with an edge distance $40 \text{ mm} \leq a_r < 50 \text{ mm}$, the characteristic load-bearing capacity for tension load shall be reduced by the factor 0.9.

fischer-Zykon-panel anchor FZP II	Annex 14 of European technical approval ETA-11/0145
Design method	

3 Design of façade panel

3.1 Determination of decisive bending moment in the façade panel

The determination of bending moments depends on the bearing mode of the façade panel. In case of uniform bearing the decisive bending moment shall be calculated according to equation (4a) and in case of non-uniform bearing it shall be calculated according to equation (4b). For the decisive bending moment the wind load and dead load of the façade panel are to be taken into account. In case of façade panel with reveal panels the wind load and dead load of the reveal panels shall be taken into account.

The decisive bending moment results from

in case of uniform bearing:
$$m_{Sd} = (m_{Sk,w} + m_{Sk,wL}) \cdot \gamma_F + (m_{Sk,gL} + m_{Sk,Zw}) \cdot \gamma_G \quad (4a)$$

in case of non-uniform bearing:
$$m_{Sd} = (m_{Sk,w} + m_{Sk,wL}) \cdot \gamma_F + m_{Sk,gL} \cdot \gamma_G \quad (4b)$$

with: $m_{Sk,w}$ = moments proportion from wind load (see section 3.1.1)
 $m_{Sk,Zw}$ = moments proportion from mounting restraint (see section 3.1.2)
 $m_{Sk,gL}$ = moments proportion from dead load reveal (see section 3.1.3)
 $m_{Sk,wL}$ = moments proportion from wind load reveal (see section 3.1.4)

3.1.1 Moments proportion from wind load

The moments proportions from wind load may be determined by means of FE program taking into account the data according to Annex 19 or simplified according to equation (5a) or (5b).

in case of uniform bearing:
$$m_{Sk,w} = \alpha_{1a} \cdot w \cdot L \cdot H \quad (5a)$$

in case of non-uniform bearing:
$$m_{Sk,w} = \alpha_{1b} \cdot w \cdot L \cdot H \quad (5b)$$

with: α_{1a} = moments coefficient according to Annex 18, chart 1
 α_{1b} = moments coefficient according to Annex 18, chart 2
 w = wind surface load
 L = panel length (horizontal direction) of the façade panel
 H = panel height (vertical direction) of the façade panel

3.1.2 Moments proportion from mounting restraint (in case of uniform bearing only)

The moments proportions from strain load may be determined by means of FE program taking into account the data according to Annex 19 or simplified according to equation (6).

$$m_{Sk,Zw} = \alpha_2 \cdot F_{Sk,Zw} \quad (6)$$

with: α_2 = moments coefficient according to Annex 18, chart 3
 $F_{Sk,Zw}$ = 0.1 kN = load from strains

fischer-Zykon-panel anchor FZP II	Annex 15 of European technical approval ETA-11/0145
Design method	

3.1.3 Moments proportion from dead load of reveal panels

The moments proportions from dead load of reveal panels may be determined by means of FE program taking into account the data according to Annex 19 or simplified according to equation (7a) or (7b).

in case of uniform bearing:
$$m_{Sk,gl} = \alpha_{3a} \cdot \frac{\rho \cdot B_L \cdot d_L \cdot (B_L + d_F)}{1.2} \quad (7a)$$

in case of non-uniform bearing:
$$m_{Sk,gl} = \alpha_{3b} \cdot \frac{\rho \cdot B_L \cdot d_L \cdot (B_L + d_F)}{1.2} \quad (7b)$$

with:
$$\alpha_{3a} = 0.67 + 0.035 \cdot \frac{H}{L}$$

$$\alpha_{3b} = 0.67 + 0.045 \cdot \frac{H}{L}$$

L = panel length (horizontal direction) of the façade panel

H = panel height (vertical direction) of the façade panel

ρ = the density according to EN 1936 taking into account the water absorption under atmospheric pressure according to EN 13755

B_L = width of reveal panel (horizontal direction)

d_L = thickness of reveal panel

d_F = thickness of façade panel

Special case lintel reveal:

For lintel reveals the moments proportion from dead load is not applicable (that shall be taken into account by an increase factor when determining the moments proportion from wind load of the reveal panels, cf. section 3.1.4).

3.1.4 Moments proportion from wind load of reveal panels

The moments proportions from wind load of reveal panels may be determined by means of FE program taking into account the data according to Annex 19 or simplified according to equation (8a) or (8b).

in case of uniform bearing:
$$m_{Sk,wL} = \alpha_{4a} \cdot \frac{w \cdot B_L \cdot (B_L + d_F)}{2} \quad (8a)$$

in case of non-uniform bearing:
$$m_{Sk,wL} = \alpha_{4b} \cdot \frac{w \cdot B_L \cdot (B_L + d_F)}{2} \quad (8b)$$

with:
$$\alpha_{4a} = 1.2 + 0.3 \cdot \left(\frac{H}{L}\right)^{1.5}$$

$$\alpha_{4b} = 1.7 + 0.5 \cdot \frac{H}{L}$$

L = panel length (horizontal direction) of the façade panel

H = panel height (vertical direction) of the façade panel

w = wind surface load

B_L = width of reveal panel (horizontal direction)

d_F = thickness of façade panel

fischer-Zykon-panel anchor FZP II

Design method

Annex 16

**of European
technical approval**

ETA-11/0145

Special case lintel reveal:

The dead loads and wind loads act perpendicular to the panel surface. As simplified model the wind load is increased by 1.4 times the dead load. The bending moment component $m_{Sk,WL}$ is calculated according to the equation (8c) or (8d) as follows:

in case of uniform bearing:
$$m_{Sk,WL} = \alpha_{4a} \cdot \frac{w \cdot B_L \cdot (B_L + d_F)}{2} + \alpha_{4a} \cdot 1.4 \cdot \frac{d_L \cdot \rho \cdot B_L \cdot (B_L + d_F)}{2} \quad (8c)$$

in case of non-uniform bearing:
$$m_{Sk,WL} = \alpha_{4b} \cdot \frac{w \cdot B_L \cdot (B_L + d_F)}{2} + \alpha_{4b} \cdot 1.4 \cdot \frac{d_L \cdot \rho \cdot B_L \cdot (B_L + d_F)}{2} \quad (8d)$$

3.2 Verification against edge failure by façade panels with reveal panels

When fixing the reveal panels on the façade panel the verification against edge failure due to loads on the reveal angle shall be carried out additionally both for reveal panel and façade panel.

The decisive bending moment may be determined by means of FE program taking into account the data according to Annex 19 or simplified according to equation (9).

$$m_{Sd} = \alpha_5 \cdot F_{Sd,L} \quad (9)$$

with: $\alpha_5 = 0.575 - 1.5 \cdot b_r \geq 0.2$
 $F_{Sd,L}$ = decisive anchor load on reveal angle
 b_r = b_{rL} or b_{rH} [m] (edge distance to reveal front according to Annex 6)

3.3 Determination of the decisive bending moment in the reveal panel

For the determination of the decisive bending moment the reveal panel shall be calculated parallel to the façade level as a beam in bending and perpendicular to the façade level as a cantilever.

Special case: lintel reveal

For the determination of the decisive bending moment the dead load loads shall be increased by the factor 1.4.

3.4 Verification of the bending stresses

The corresponding bending stresses are to be determined from the decisive bending moments according to sections 3.1, 3.2 and 3.3 by means of equation (10).

For the bending stresses shall be verified that equation (11) was taken into account.

$$\sigma_{Sd} = \frac{6 \cdot m_{Sd}}{d^2} \quad (10)$$

$$\sigma_{Sd} \leq \sigma_{Rd} \quad (11)$$

with σ_{Sd} = design value of existing bending stress in the façade panel/ reveal panel
 m_{Sd} = design value of decisive bending moment according to 3.1, 3.2 or 3.3
 d = d_F or d_L (panel thickness of the façade panel or reveal panel)
 σ_{Rd} = design value of bending strength
 $\sigma_{Rd} = \sigma_{Rk} / \gamma_M$
 with σ_{Rk} ; γ_M according to Annex 5, Table 5

fischer-Zykon-panel anchor FZP II

Design method

Annex 17

**of European
technical approval**

ETA-11/0145

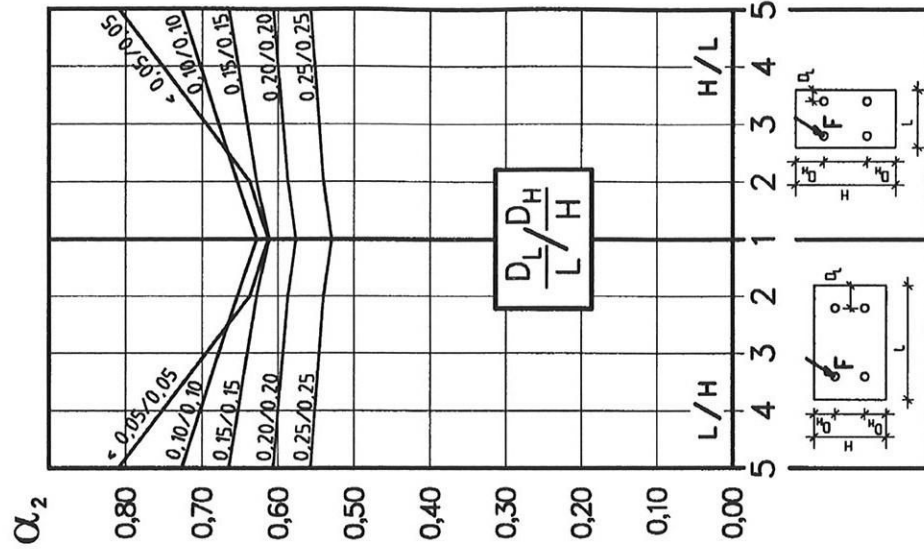

Chart 3: moments coefficient α_2 for strain load in case of uniform bearing

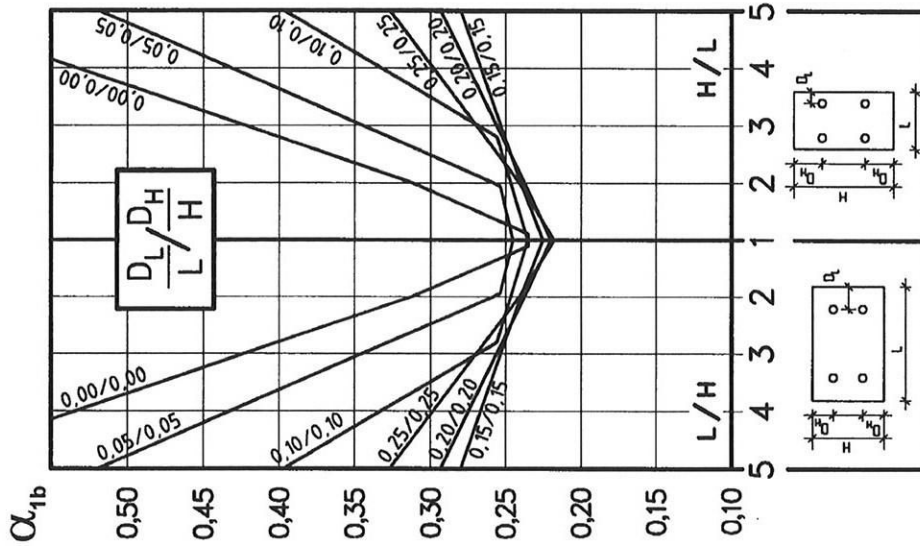

Chart 2: moments coefficient α_{1b} for wind load in case of non-uniform bearing

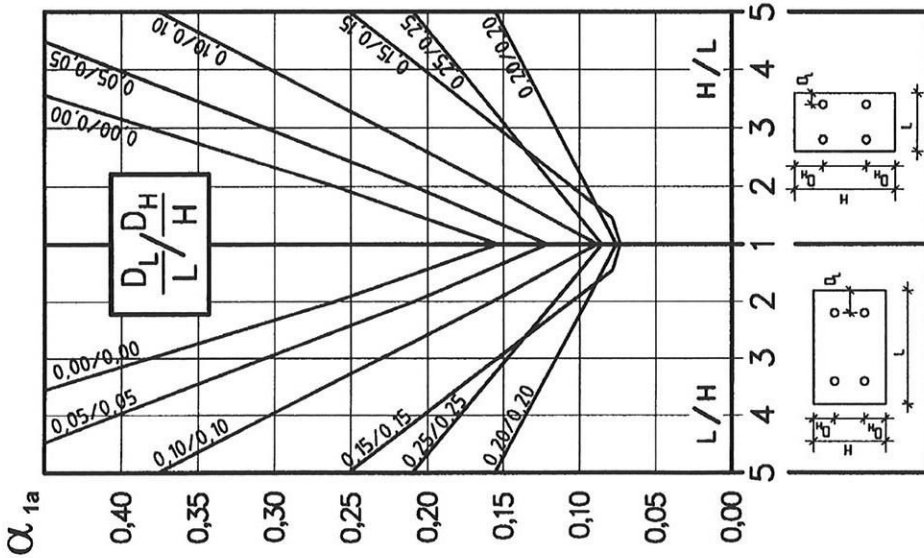

Chart 1: moments coefficient α_{1a} for wind load in case of uniform bearing

fischer-Zykon-panel anchor FZP II

Design method

Annex 18

of European technical approval

ETA-11/0145

Guideline for structural calculation by means of the Finite-Element-Method

1. The calculation shall be carried out in a linear elastic manner. The system chosen shall have the capacity to sufficiently precise represent the tension and the deformation state as well as the support reactions of the façade panels.
2. The façade panels are to be idealized with their effective dimensions (size and thickness) as panel elements.
3. The modelling of the façade panel is to be calibrated on the basis of the following points:
 - For the panel format given in Table 10 the support moment m_s with an identical mesh size in the fixing range (fixing range $>10d$) shall be calculated for the respective loads. The calculated support moments shall not fall below the values given in Table 10 (a tolerance of 5 % is permissible). The modelling may be optimised by means of variations of the mesh size at fixing range. The mesh size in fixing range chosen shall be applied to all panels.
 - The calibration is carried out with a modulus of elasticity $E = 50000 \text{ N/mm}^2$ and a radical strain coefficient $\nu = 0.2$. The loads given shall be used without additional safety factors.
 - At least two meshes are to be placed between anchor axle and panel edge.
4. On the basis of the calibrated model the panels of any geometry that are fixed on four anchors can be determined. The mesh size as well as the size of fixing range shall not be changed.

Table 10: Support moment m_s [kNm/m] to verify the model calibration

		Support moment m_s		
		Figure 8	Figure 9	Figure 10
Panel format				
H = 1m; L = 2m; d = 20mm	$E_L/L = E_H/H = 0,20$	0,0953	0,2374	0,5873
w = 0.5 kN/m ² / F _{Zw} = 1.0 kN				

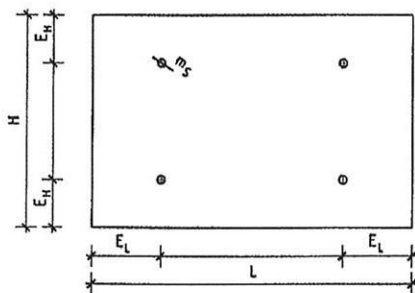

Figure 8:
Moment from wind load w
in case of uniform bearing
(Panel is fixed on 4 points)

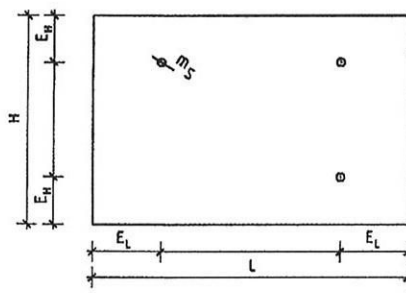

Figure 9:
Moment from wind load w
in case of non-uniform bearing
(Panel is fixed on 3 points)

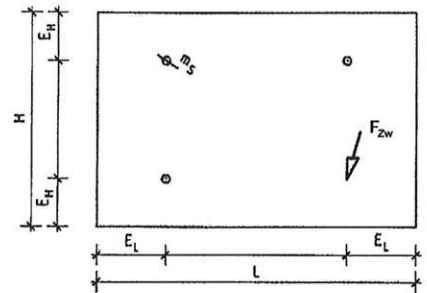

Figure 10:
Moment from strain load F_{Zw}
in case of uniform bearing
(Panel is fixed on 3 points)

fischer-Zykon-panel anchor FZP II

Guideline for structural calculation
by means of the Finite-Element-Method

Annex 19

**of European
technical approval**

ETA-11/0145