

European Technical Approval ETA-06/0253

English translation prepared by DIBt - Original version in German language

Handelsbezeichnung <i>Trade name</i>	KEIL Hinterschnittanker KH <i>KEIL undercut anchor KH</i>	
Zulassungsinhaber <i>Holder of approval</i>	KEIL Befestigungstechnik GmbH Im Auel 42 51766 Engelskirchen DEUTSCHLAND	
Zulassungsgegenstand und Verwendungszweck <i>Generic type and use of construction product</i>	Spezialdübel zur rückseitigen Befestigung von Fassadenplatten aus ausgewählten Naturwerksteinen nach EN 1469 <i>Special Anchor for the fixing of façade slabs from their back side made of selected natural stones according to EN 1469</i>	
Geltungsdauer: <i>Validity:</i>	vom <i>from</i>	5 August 2008
	bis <i>to</i>	24 November 2011
verlängert <i>extended</i>	vom <i>from</i>	25 November 2011
	bis <i>to</i>	25 November 2016
Herstellwerk <i>Manufacturing plant</i>	KEIL Befestigungstechnik GmbH, Deutschland	

Diese Zulassung umfasst
This Approval contains

25 Seiten einschließlich 17 Anhänge
25 pages including 17 annexes

I LEGAL BASES AND GENERAL CONDITIONS

- 1 This European technical approval is issued by Deutsches Institut für Bautechnik in accordance with:
 - Council Directive 89/106/EEC of 21 December 1988 on the approximation of laws, regulations and administrative provisions of Member States relating to construction products¹, modified by Council Directive 93/68/EEC² and Regulation (EC) N° 1882/2003 of the European Parliament and of the Council³;
 - *Gesetz über das In-Verkehr-Bringen von und den freien Warenverkehr mit Bauprodukten zur Umsetzung der Richtlinie 89/106/EWG des Rates vom 21. Dezember 1988 zur Angleichung der Rechts- und Verwaltungsvorschriften der Mitgliedstaaten über Bauprodukte und anderer Rechtsakte der Europäischen Gemeinschaften (Bauproduktengesetz - BauPG) vom 28. April 1998⁴, as amended by law of 31 October 2006⁵;*
 - Common Procedural Rules for Requesting, Preparing and the Granting of European technical approvals set out in the Annex to Commission Decision 94/23/EC⁶.
- 2 Deutsches Institut für Bautechnik is authorized to check whether the provisions of this European technical approval are met. Checking may take place in the manufacturing plant. Nevertheless, the responsibility for the conformity of the products to the European technical approval and for their fitness for the intended use remains with the holder of the European technical approval.
- 3 This European technical approval is not to be transferred to manufacturers or agents of manufacturers other than those indicated on page 1, or manufacturing plants other than those indicated on page 1 of this European technical approval.
- 4 This European technical approval may be withdrawn by Deutsches Institut für Bautechnik, in particular pursuant to information by the Commission according to Article 5(1) of Council Directive 89/106/EEC.
- 5 Reproduction of this European technical approval including transmission by electronic means shall be in full. However, partial reproduction can be made with the written consent of Deutsches Institut für Bautechnik. In this case partial reproduction has to be designated as such. Texts and drawings of advertising brochures shall not contradict or misuse the European technical approval.
- 6 The European technical approval is issued by the approval body in its official language. This version corresponds fully to the version circulated within EOTA. Translations into other languages have to be designated as such.

¹ Official Journal of the European Communities L 40, 11 February 1989, p. 12
² Official Journal of the European Communities L 220, 30 August 1993, p. 1
³ Official Journal of the European Union L 284, 31 October 2003, p. 25
⁴ *Bundesgesetzblatt Teil I 1998*, p. 812
⁵ *Bundesgesetzblatt Teil I 2006*, p. 2407, 2416
⁶ Official Journal of the European Communities L 17, 20 January 1994, p. 34

II SPECIFIC CONDITIONS OF THE EUROPEAN TECHNICAL APPROVAL

1 Definition of the product and intended use

1.1 Definition of the product

The KEIL undercut anchor KH is a special anchor made of stainless steel consisting of a crosswise slotted anchor sleeve with an M6 internal thread, at the upper edge of which a hexagon is formed to it and a respective hexagon bolt with an integrated tooth lock washer as well as distance washer for levelling of thickness tolerances $\Delta d_p = +6 \text{ mm} / \pm 0 \text{ mm}$. Alternatively, instead of the hexagon bolt with an integrated tooth lock washer, a threaded pin or threaded rod may be used. The anchor is put into an undercut drill hole and by driving-in the screw it is placed form-fitted and deformation-controlled.

Annex 1 shows the anchor at built-in state.

1.2 Intended use

The anchor may only be used for the rear fixing of façade slabs of natural stone according to EN 1469:2004. The façade slabs shall correspond to EN 1469:2004, the drawings and to the indications given in the annexes and may only be made of the natural stones according to Table 1. It must be ensured that the material used is free of crevices and mechanical effective cracks and alterations.

Table 1: Selected natural stones

Group of stone		Natural stones
I	High-quality intrusive rocks (plutonic rocks)	e.g.: granite, granitite, syenite, tonalite, diorite, monzonite, gabbro other magmatic plutonic rocks
II	Metamorphic rocks with "hard stone character"	e.g.: quartzite, granulite, gneiss, migmatite
III	Sedimentary rocks with "hard stone character" ^{7 8}	sandstone and limestone

The façade slabs with rear fixing by the anchor may only be used for front curtain walls. Each façade slab shall be fixed technically strain-free with four anchors in a rectangular arrangement on a capable substructure.

The anchor may be used in structures subject to dry internal conditions and also in structures subject to external atmospheric exposure (including industrial and marine environment), if no particular aggressive conditions exist. Such particular aggressive conditions are e.g. permanent, alternating immersion in seawater or the splash zone of seawater, chloride atmosphere of indoor swimming pools or atmosphere with extreme chemical pollution (e.g. in desulphurisation plants or road tunnels where de-icing materials are used).

The provisions made in this European Technical Approval are based on an assumed working life of the anchor of 50 years. The indications given on the working life cannot be interpreted as a guarantee given by the producer, but are to be regarded only as a means for choosing the right products in relation to the expected economically reasonable working life of the works.

⁷ For façade slabs made of sandstone the density shall be at least 2.1 kg/dm³.

⁸ For façade slabs made of natural stones with planes of anisotropy, the difference between the bending strengths determined parallel to the planes of anisotropy and perpendicular to the edges of the planes of anisotropy shall not be more than 50 %.

2 Characteristics of the product and method of verification

2.1 Characteristics of the product

The anchor corresponds to the drawings and specifications given in Annex 2. The characteristic material values, dimensions and tolerances of the anchor not indicated in Annex 2 shall correspond to the respective values laid down in the technical documentation⁹ of this European technical approval.

The anchor is considered to satisfy the requirements for performance class A1 of the characteristic reaction to fire, in accordance with the provisions of EC decision 96/603/EC (as amended) without the need for testing on the basis of its listing in that decision.

In addition to the specific clauses relating to dangerous substances contained in this European Technical Approval, there may be other requirements applicable to the products falling within its scope (e.g. transposed European legislation and national laws, regulations and administrative provisions). In order to meet the provisions of the Construction Products Directive, these requirements need also to be complied with, when and where they apply.

The characteristic values for the design of the façade slabs with rear fixing by the anchor are given in Annex 4.

Every anchor is marked with the identifying mark of the producer and the anchor size according to Annex 2.

The anchor shall be packed and delivered as fixing unit (cone bolt, expansion ring, sleeve).

2.2 Methods of verification

The assessment of fitness of the anchor for the intended use in relation to the requirement for safety in use in the sense of the essential requirement N^o4 of Council Directive 89/106/EEC has been made based on the following tests carried out:

- (1) Axial tension tests
- (2) Shear tests
- (3) Tests with combined tension and shear loading
- (4) Tests on structural members
- (5) Tests on functioning under repeated loads
- (6) Tests on functioning under sustained loads
- (7) Tests on functioning under freeze/thaw conditions (25 freeze/thaw cycles)
- (8) Tests on functioning after immersion in water.

⁹ The technical documentation comprises all information necessary for the production, installation and maintenance of the anchor; these are in particular the design drawings and the installation instructions. The part to be treated confidentially is deposited with Deutsches Institut für Bautechnik and, as far as this is relevant to the tasks of the approved bodies involved in the procedure of attestation of conformity, shall only be handed over to the approved body.

3 Evaluation and attestation of conformity and CE marking

3.1 System of attestation of conformity

According to the communication of the European Commission¹⁰ the system 2 (ii)-1 (referred to as System 2+) of attestation of conformity applies.

These systems of attestation of conformity are defined as follows:

System 2+: Declaration of conformity of the product by the manufacturer on the basis of:

(a) Tasks for the manufacturer:

- (1) initial type-testing of the product;
- (2) factory production control;
- (3) testing of samples taken at the factory in accordance with a prescribed test plan.

(b) Tasks for the approved body:

- (4) certification of factory production control on the basis of:
 - initial inspection of factory and of factory production control;
 - continuous surveillance, assessment and approval of factory production control.

3.2 Responsibilities

3.2.1 Tasks for the manufacturer

3.2.1.1 Factory production control

The manufacturer shall exercise permanent internal control of production. All the elements, requirements and provisions adopted by the manufacturer shall be documented in a systematic manner in the form of written policies and procedures, including records of results performed. This production control system shall insure that the product is in conformity with this European Technical Approval.

The manufacturer may only use initial materials and components stated in the technical documentation of this European Technical Approval.

The factory production control shall be in accordance with the control plan¹¹ which is part of the technical documentation of this European Technical Approval. The control plan is laid down in the context of the factory production control system operated by the manufacturer and deposited with Deutsches Institut für Bautechnik.

The results of factory production control shall be recorded and evaluated in accordance with the provisions of the control plan.

3.2.1.2 Other tasks for the manufacturer

The manufacturer shall, on the basis of a contract, involve a body which is approved for the tasks referred to in section 3.1 in the field of "anchors" in order to undertake the actions laid down in section 3.3. For this purpose, the control plan referred to in sections 3.2.1.1 and 3.2.2 shall be handed over by the manufacturer to the approved body involved.

The manufacturer shall make a declaration of conformity, stating that the construction product is in conformity with the provisions of this European Technical Approval.

¹⁰ Letter of the European Commission of 22/07/2002 to EOTA

¹¹ The control plan is a confidential part of the European technical approval and only handed over to the approved body involved in the procedure of attestation of conformity. See section 3.2.2.

3.2.2 Tasks of approved bodies

The approved body shall perform the following tasks in accordance with the provisions laid down in the control plan:

- initial inspection of factory and of factory production control,
- continuous surveillance, assessment and approval of factory production control.

The approved body shall retain the essential points of its actions referred to above and state the results obtained and conclusions drawn in a written report.

The approved certification body involved by the manufacturer shall issue an EC certificate of conformity of the factory production control stating the conformity with the provisions of this European Technical Approval.

In cases where the provisions of the European Technical Approval and its control plan are no longer fulfilled the certification body shall withdraw the certificate of conformity and inform Deutsches Institut für Bautechnik without delay.

3.3 CE marking

The CE marking shall be affixed on the packaging or accompanying commercial document, e.g. the EC declaration of conformity. The letters "CE" shall be followed by the identification number of the approved certification body, where relevant, and be accompanied by the following additional information:

- the name and address of the producer (legal entity responsible for the manufacture),
- the last two digits of the year in which the CE marking was affixed,
- the number of the EC certificate for the factory production control,
- the number of the European technical approval,
- use category (25 freeze/thaw cycles),
- size.

4 Assumptions under which the fitness of the product for the intended use was favourably assessed

4.1 Manufacture

The European Technical Approval is issued for the product on the basis of agreed data/information, deposited with Deutsches Institut für Bautechnik, which identifies the product that has been assessed and judged. Changes to the product or production process, which could result in this deposited data/information being incorrect, should be notified to Deutsches Institut für Bautechnik before the changes are introduced. Deutsches Institut für Bautechnik will decide whether or not such changes affect the ETA and consequently the validity of the CE marking on the basis of the ETA and if so whether further assessment or alterations to the ETA shall be necessary.

4.2 Installation

4.2.1 Design of the fixings

The fitness of the anchor for the intended use is given under the following conditions:

- The façade slabs correspond to EN 1469:2004 and to the indications given in the annexes; the characteristic values of material of the façade slabs are determined and declared according to Annex 9;

- As a rule each façade slab is fixed with four anchors in rectangular arrangement to the substructure; only stand-off fixing anchors are used (see Annex 1); the characteristic values of the anchor, the edge distances and spacing, as well as the characteristic values of the slabs according to Annex 4 are observed.
- The façade slabs neither are used to transmit impact loads nor for guard rail.
- The substructure is constructed such that the façade slabs are fixed technically strain-free via three loose bearings and one fixed bearing (see Annex 6). Two fixing points of the façade slab are designed such that they are able to carry the dead load of the façade slab. When using agraffes on horizontal load-bearing profiles the fixing points of a façade slab situated horizontally at the same height are fastened in each case to the same load-bearing profile.
- As a rule reveal slabs are fastened to the façade slab with two angle supports according to Annex 7 and flush fixing anchors are used (see Annex 1); it is ensured that the reveal angles are resting against the slabs; when using reveal angles with elongated holes a defined load transmission (e.g. clutch disc or interlocking of the washer to the surface of the angle) in the direction of the elongated hole is ensured; the edge distances according to Annex 4 are not fallen below; the minimum spacing between the anchors of the façade slab and the anchors of the reveal angles resting in the façade slabs amounts to more than $8 \times h_s$ (h_s = setting depth of the anchor).
- Joint constructions between the façade slabs are done by a joint profile, permanently elastic filler or are kept open; it is ensured that additional stresses (e.g. by temperature) do not lead to important additional loadings.
- The façade and reveal slabs, their fixings as well as the substructure including its connection to wall brackets and their connection to the construction works are designed under the responsibility of an engineer skilled in the field of façade construction taking account the load effects (dead load, wind load) for the respective case of application; the stiffness of the substructure will be considered for the respective case of application; the loading of the reveal angles in the case of service load will be verified by calculation; taking account of the loads to be fixed checkable calculations and construction drawings are prepared; the position of the anchor is given in the construction drawings.
- When using horizontal load-bearing profiles the following shall be verified:
 - The agraffes do not prop on the façade panel due to torsion of the horizontal load-bearing profile and twisting of the façade panel.
 - The total of the angle α results from torsion of the horizontal load-bearing profile and twisting of the façade panel at the fixing point does not exceed the value $\alpha = 2^\circ$.
- Design of the anchor and the façade and reveal slabs is carried out according to the design method according to Annexes 11 to 17.

4.2.2 Installation of the anchors

The fitness for use of the anchor can be assumed only, if the following installation conditions are observed:

- Installation by appropriately qualified personnel under the supervision of the project supervisor
- Installation only as delivered by the manufacturer without exchanging the individual parts.
- Installation according to manufacturer's specifications and construction drawings using the tools indicated in the installation instructions.

- Making of the undercut drilling is done with the drill bit according to Annex 3 and a special drilling device in accordance with the information deposited with Deutsches Institut für Bautechnik.
- The drillings are done at the factory or on site under workshop conditions; when making the drillings on site the execution is supervised by the responsible project supervisor or a skilled representative of the project supervisor.
- The drillings are removed from the drill hole; the nominal diameter of the drill corresponds to the values of Annex 3; in case of aborted drill hole a new drilling at a minimum spacing of at least twice the depth of the aborted drill hole is arranged.
- The geometry of the drill hole is checked on 1 % of all drillings. The following dimensions shall be checked and documented according to manufacturer's information and testing instructions by means of a measuring device according to Annex 3:
 - Volume of the undercut drill hole;
 - Depth position of the undercut; the distance between the lower edge of the measuring device and the façade slab is between 0.0 and 0.3 mm (see Annex 3).

If the tolerances given in Annex 2, Table 1 are exceeded, the geometry of the drill hole shall be checked on 25% of the drillings performed. No further drill hole may exceed the tolerances otherwise all the drill holes shall be controlled. Drilling holes falling below or exceeding the tolerances shall be rejected.

- Between agraffe and façade slab an elastic sandwich layer may be placed.
- Fixing the screw with a torque moment $2.5 \text{ Nm} \leq T_{\text{inst}} \leq 4.0 \text{ Nm}$ using a calibrated torque
- During transport and storage on site the façade slabs are protected from damages; the façade slabs are not to be hung up jerkily (if need be lifters shall be used for hanging up the façade slabs); façade slabs and reveal slabs respectively with incipient cracks are not to be installed.
- The façade are installed by skilled specialists and the laying instructions of the manufacturer shall be paid attention to.

5 Indications to the manufacturer

It is the responsibility of the manufacturer to ensure that the information on the specific conditions according to 1 and 2 including Annexes referred to and 4.2.1 and 4.2.2 is given to those who are concerned. This information may be made by reproduction of the respective parts of the European Technical Approval. In addition all installation data shall be shown clearly on the package and/or on an enclosed instruction sheet, preferably using illustration(s).

The minimum data required are:

- maximum possible setting depth;
- thickness of the joint structure;

All data shall be presented in a clear and explicit form.

Georg Feistel
Head of Department

beglaubigt:
K. Bürger

I Product and intended use

Example without distance washer

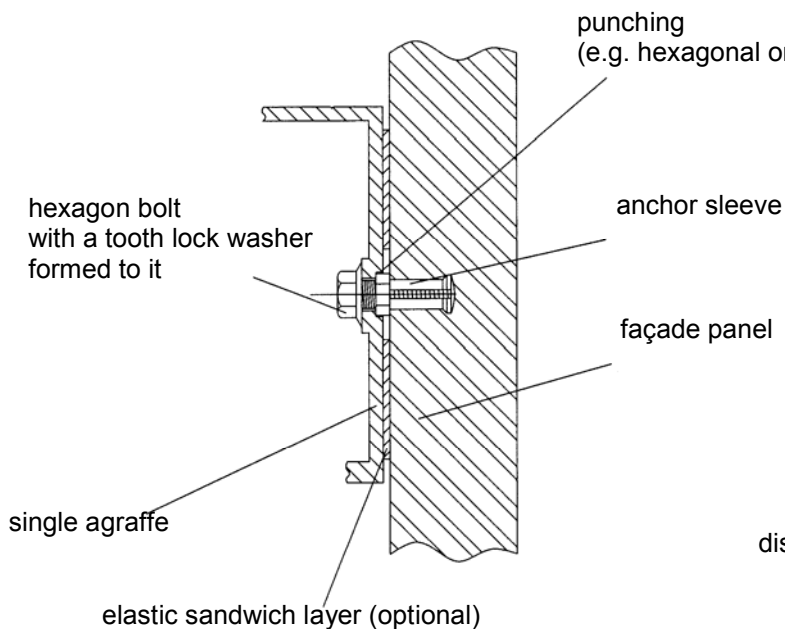

Example with distance washer

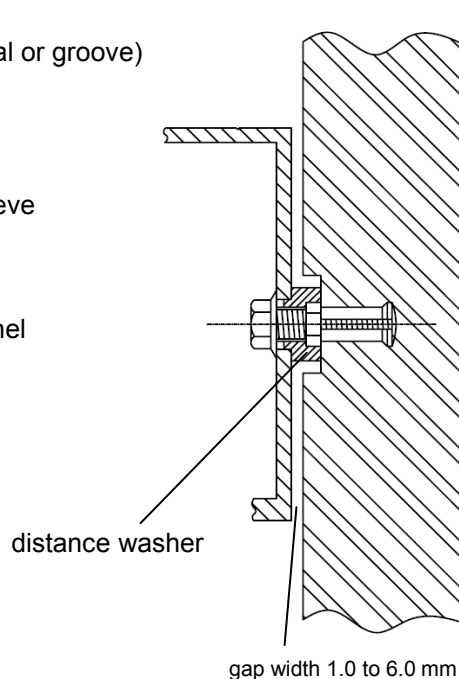

Stand-off fixing
(only for facade panel)

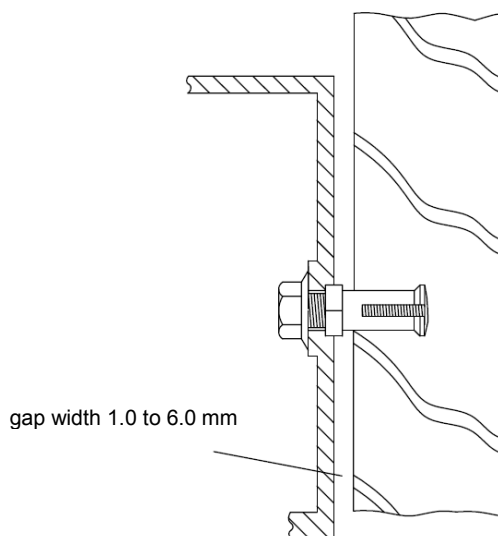

Flush fixing
(only for reveal panel)

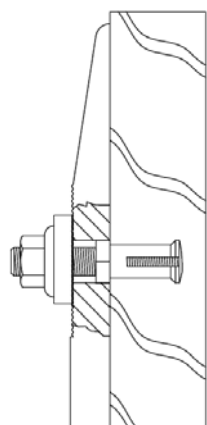

KEIL undercut anchor KH

Product and intended use

Annex 1

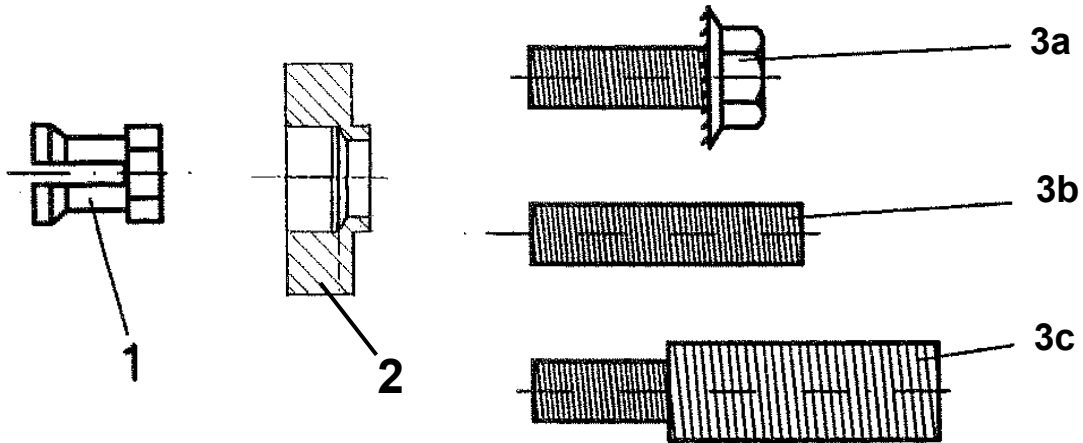
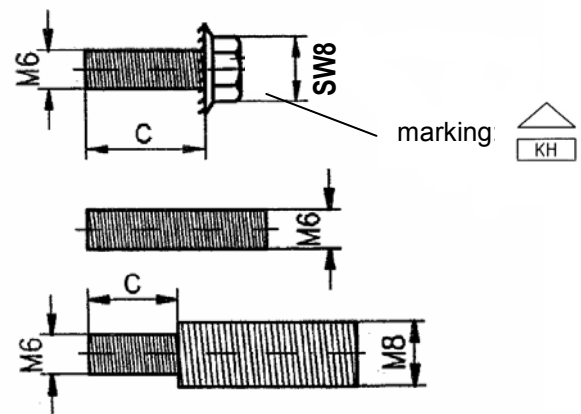
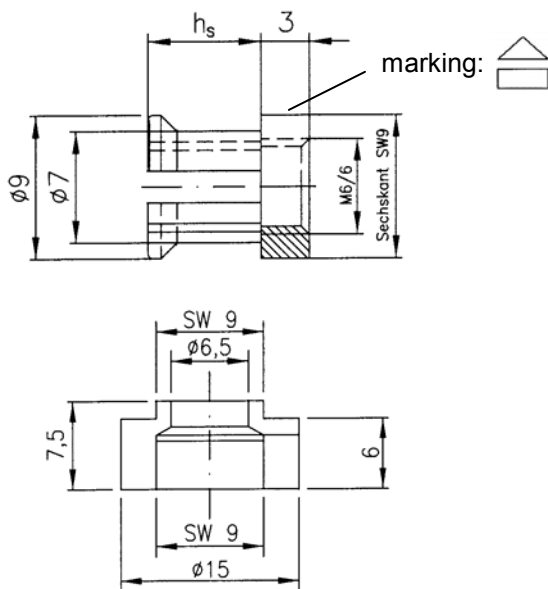

Table 1: anchor parts

part	denomination	material
1	anchor sleeve	stainless steel DIN EN 10088 – 1.4404
2	distance washer	aluminium 3.1645
3a	hexagon bolt with a tooth lock washer formed to it	stainless steel DIN EN 10088 – 1.4401, 1.4404 or 1.4578
3b	threaded pin	stainless steel DIN EN 10088 – 1.4401, 1.4404 or 1.4578
3c	threaded rod	stainless steel DIN EN 10088 – 1.4401, 1.4404 or 1.4578



c: the length of the thread has to be adapted to the respective substructure and setting depth of the anchor

KEIL undercut anchor KH

Parts of anchor

Annex 2

drill hole geometry

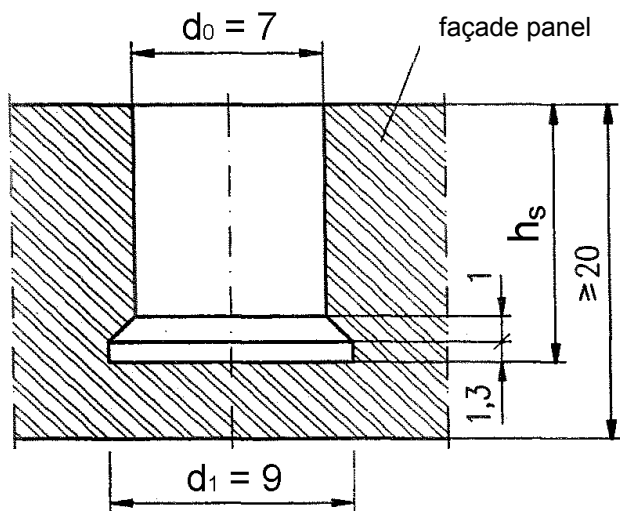

drill geometry

for KEIL - Façade drill DIA 15/1.3
without counterbore with counterbore

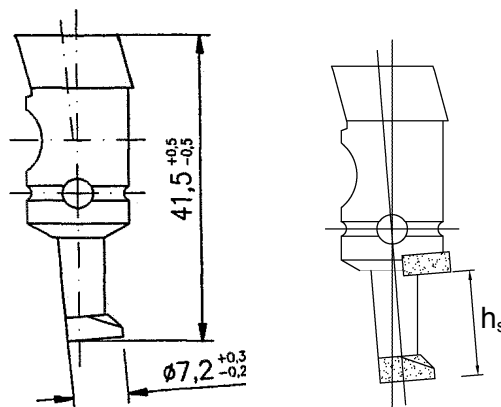

KEIL measuring device

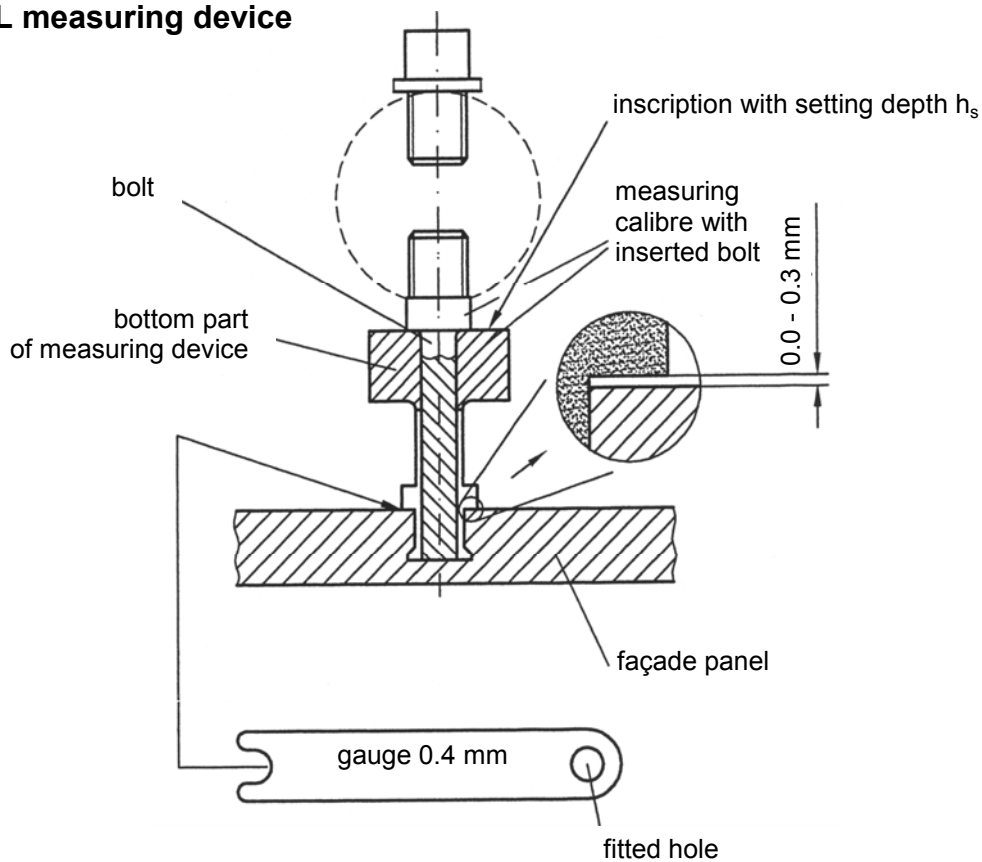

dimensions in mm

KEIL undercut anchor KH

Panel drill and geometry of the drill hole
Setting tools and testing equipment

Annex 3

Table 2: Characteristic values of anchors and façade and reveal panel made of natural stones ¹⁾

Façade panel		
slab thickness ²⁾	d [mm]	20(30) ≤ d ≤ 70
maximum size of panel	A ≤ [m ²]	3.0
maximum side length	H or L ≤ [m]	3.0
number of anchors (rectangular arrangement)		4
edge distance ³⁾	D _L or D _H	50 mm ≤ a _{rH} or.. a _{rL} ≤ 0.25L or 0.25H
spacing ³⁾	a _L or a _H ≥ [mm]	8 h _s
Reveal panel		
panel thickness ²⁾	d = [mm]	20(30) ≤ d ≤ 70
edge distance ³⁾	b _{rL} or b _{rH}	40 mm ≤ b _{rL} or b _{rH} = 0.2H or 0.2L
anchor		
anchorage depth	h _s [mm]	10 or 15
nominal diameter of drill hole	∅ d ₀ = [mm]	7
screw length	without distance washer	h _s + 3 mm + t _{fix}
	with distance washer	h _s + 7.5 mm + t _{fix}
remaining wall thickness ⁴⁾	R ≥ [mm]	0.4 d
Characteristic load-bearing capacity – façade panel (anchor load-bearing capacity, bending strength)		
tension load	N _{RK} = [kN]	see Annex 5 (depending on material, chosen slab thickness, anchorage depth and relative edge distance)
shear load	V _{RK} = [kN]	
bending stress	σ _{RK} = [N/mm ²]	see Annex 5 (depending on material)
partial safety factor ⁵⁾	γ _M = [-]	see Annex 5 (depending on material)
Characteristic load-bearing capacity – anchor (steel failure)		
tension load	N _{RK,S} = [kN]	14.1
partial safety factor ⁵⁾	γ _{M,S} = [-]	1.87
shear load	V _{RK,S} = [kN]	7.0
partial safety factor ⁵⁾	γ _{M,S} = [-]	1.56

¹⁾ natural stones according to section 1.2

²⁾ for sandstone and limestone: panel thickness d ≥ 30 mm

³⁾ for small fitted pieces, differential or fill-in pieces the minimum edge distance or spacing shall be chosen constructively.

⁴⁾ only for stand-off fixing

⁵⁾ recommended partial safety factor in absence of other national regulations

KEIL undercut anchor KH

Characteristic values of anchors and panels

Annex 4

Charakteristic load-bearing capacity - façade panel (anchor load-bearing capacity, bending strength)

Charakteristic anchor load-bearing capacity N_{Rk} and V_{Rk}

Depending on the respective natural stone, the panel thickness, setting depth and edge distance of the anchor the characteristic load-bearing capacity N_{Rk} (tension load) and V_{Rk} (shear load) result as follows:

$$N_{Rk} = N_{u5\%} \cdot \alpha_{exp}$$

$$V_{Rk} = V_{u5\%} \cdot \alpha_{exp}$$

Charakteristic value of bending strength σ_{Rk}

Depending on the respective natural stone the characteristic value of bending strength results as follows:

$$\sigma_{Rk} = \sigma_{u5\%} \cdot \alpha_{exp}$$

Exposition factor α_{exp}

Depending on the respective natural stone for consideration of deterioration of strength due to exposure (freeze-thaw-stress, moisture penetration) the following factor shall be determined:

$$\alpha_{exp} = 1.25 \cdot \sigma_{Rum,exp} / \sigma_{Rum} \leq 1.0$$

(simplified, for natural stones of stone group I and II, it can be assumed that the exposition factor is $\alpha_{exp} = 1.0$)

Partial safety factor γ_M

In absence of other national regulations the following partial safety factor for façade material is recommended:

$$\gamma_M = 1.8 \cdot \gamma_1 \cdot \gamma_2$$

Charakteristic value of material depending on the respective natural stone

$N_{u5\%}$ = lower expectation value of ultimate load due to tension at the anchor, depending on panel thickness, setting depth and edge distance of the anchor (according to Annex 9)

$V_{u5\%}$ = lower expectation value of ultimate load due to shear at the anchor, depending on panel thickness, setting depth and edge distance of the anchor (according to Annex 9)

$\sigma_{u5\%}$ = lower expectation value of bending strength (according to Annex 9)

σ_{um} = average value of bending strength (according to Annex 9)

$\sigma_{um,exp}$ = average value of bending strength after weathering (according to Annex 9)

γ_1 = 1.25 if the tests for determination of $N_{u5\%}$, $V_{u5\%}$ and $\sigma_{u5\%}$ date back more than 2 years ¹⁾

= 1.0 if the tests for determination of $N_{u5\%}$, $V_{u5\%}$ and $\sigma_{u5\%}$ date back less than 2 years ¹⁾

γ_2 = $1 + (v[\%] - 15) \cdot 0.03 \geq 1.0$ mit v = coefficient of variation determined from the declared values of standard deviation and average value

¹⁾ Due to the alterability of natural stone the actual strength values of the material installed may deviate from the declared values. The partial safety factor γ_1 considers at which date the characteristic values of the material have been determined.

KEIL undercut anchor KH

Characteristic load-bearing capacity

Annex 5

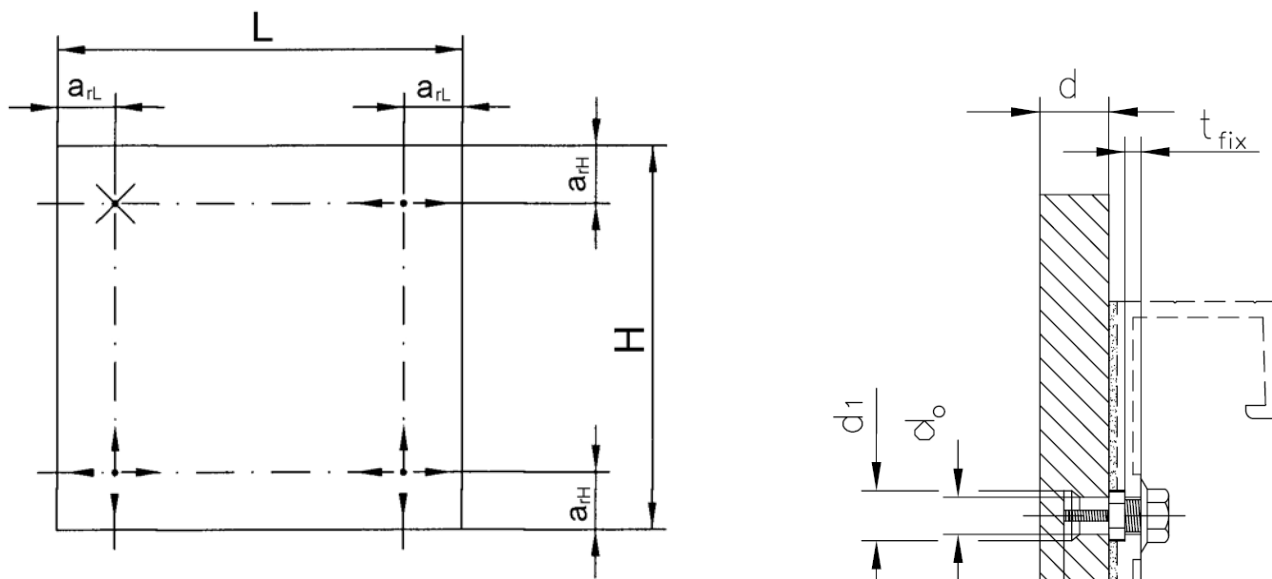

Legend

- = fixed point between panel and substructure
- = horizontal loose-bearing point (skid) between panel and substructure
- = horizontal and vertical loose-bearing point (skid) between panel and substructure

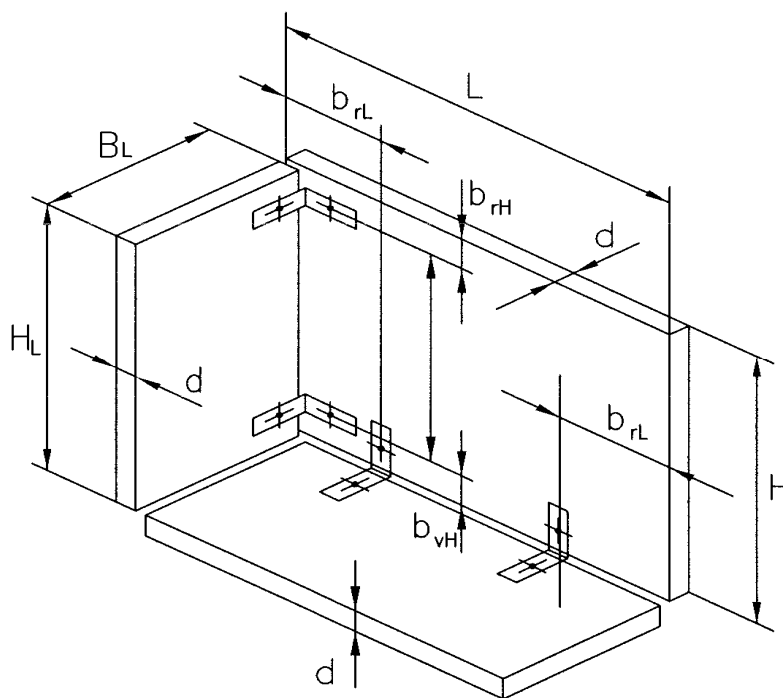

KEIL undercut anchor KH

Definition of dimensions

Annex 6

Table 3: Characteristic values of the reveal angles

		stainless steel 1.4401, 1.4404 or 1.457 EN 10 088-3	aluminium EN 755-1
angle thickness	t [mm]	$t \geq 4$	$t \geq 5$
angle width	a [mm]	$40 \leq a \leq 100$	$40 \leq a \leq 100$
Distance between the centre of anchor to outer edge of reveal angle	b_1 [mm]	$25 \leq b_1 \leq 10 t$	$25 \leq b_1 \leq 8 t$
Distance between the centre of anchor to inner edge of reveal angle	b_2 [mm]	$40 \leq b_2 \leq 10 t$	$40 \leq b_2 \leq 8 t$
cross tension stiffness	c_q [MN/m]	$c_q \leq 2.5$ ¹⁾	

¹⁾ see Annex 12 - 2.2 Determination of the anchor loads on the fixing points of reveal angle

Denominations of dimensions of the reveal angles

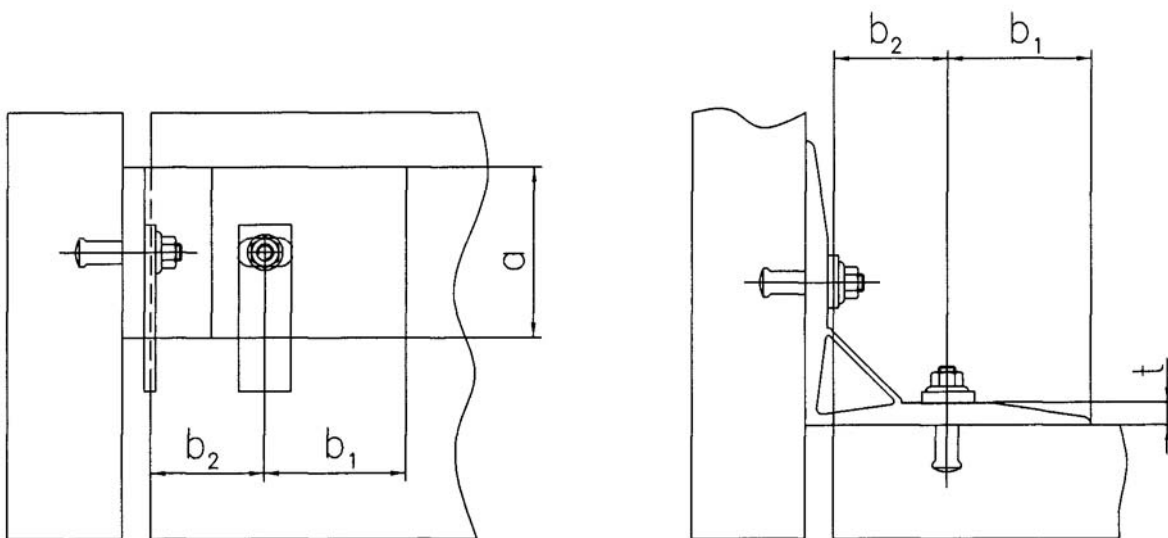

KEIL undercut anchor KH

Reveal angle

Annex 7

Example of a substructure

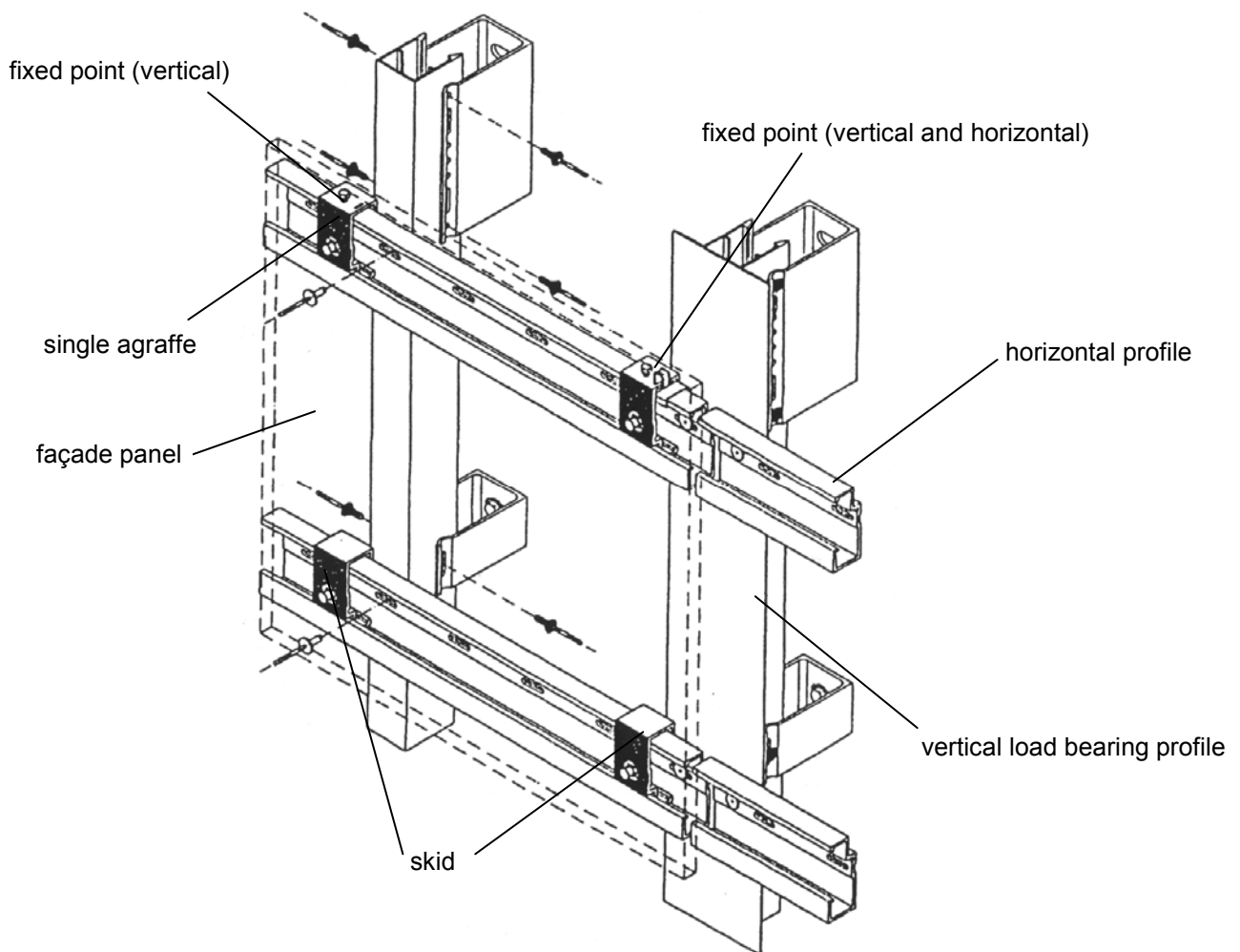

KEIL undercut anchor KH

Example of substructure and fixing of the slab

Annex 8

II Determination of the characteristic values of material

1. General

Natural stones for cladding panels are harmonised by EN 1469. Hence the natural stone panels shall be classified according to EN 1469 and the CE-marking shall be affixed.

2. Determination of the characteristic values of material ¹⁾

2.1 bending strength ($\sigma_{u5\%}$, σ_{um})

According to EN 1469 the bending strength shall be determined from tests according to EN 12372 or EN 13161²⁾. From the test results the lower expectation value $\sigma_{5\%}$ ³⁾, the average value σ_{um} and the standard deviation shall be determined.

2.2 Ultimate load of the anchor ($N_{u5\%}$, $V_{u5\%}$)

The ultimate load of the anchor due to tension load and shear load⁴⁾ shall be determined by tests. Considering the panel thickness, setting depth and edge distance of the anchor tests shall be performed according to Annex 10, Table 4. From the test results the lower expectation value $N_{u5\%}$ or $V_{u5\%}$ ³⁾ respectively, the average value N_{um} or V_{um} respectively and the standard deviation shall be determined with respect to the panel thickness, the setting depth and edge distance of the anchor.

2.3 Bending strength after weathering ($\sigma_{um,exp}$)

The bending strength after weathering $\sigma_{um,exp}$ shall be determined as follow:

$$\sigma_{um,exp} = \sigma_{um,A} \text{ Or } \sigma_{um,exp} = \min(\sigma_{um,B}, \sigma_{um,C})$$

$\sigma_{um,A}$ = average value of bending strength after freeze-thaw-cycle tests according to DIN 52008:2006-07, Annex C determined on wet samples, which have been previously immersed in water for 2h to 3h

$\sigma_{um,B}$ = average value of bending strength after freeze-thaw-cycle tests according to EN 12371

$\sigma_{um,C}$ = average value of bending strength determined on wet samples, which have been previously immersed in water for 2h to 3h

The bending strength after weathering ($\sigma_{um,exp}$) shall be determined from tests according to EN 12372 or EN 13161²⁾. The samples for determination of the bending strength without weathering (σ_{um}) and after weathering ($\sigma_{um,exp}$) shall be made from one and the same charge.

Notes:

- 1) For natural stones with planes of anisotropy the position of the planes of anisotropy shall be considered (see Figure 1 to Figure 3)

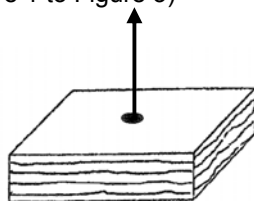

Figure 1: Type I

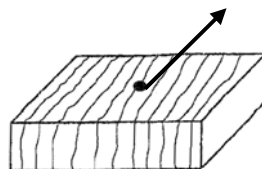

Figure 2: Type IIa

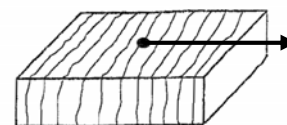

Figure 3: Type IIb

- 2) For evaluation and comparison of bending strengths (e.g. after freeze-thaw-cycles or for the proof of the stability) the tests shall be performed always with the same test methods and the same dimensions of the test members
- 3) 5%-Fractile, confidence level of 75%, unknown standard deviation and lognormal distribution
- 4) For anchors in stand-off fixing or with distance washer, the shear tests shall be performed with the maximum possible distance

KEIL undercut anchor KH

Determination of the characteristic values of material

Annex 9

Table 4: Tests on anchors fixed in panel sections

	panel thickness ³⁾	setting depth	edge distance		dimension of test member		diameter of support	number of tests			
	d	h _s	a _{rH}	a _{rL}	H	L	∅ _s	n			
	[mm]	[mm]	[mm]		[mm]		[mm]	[-]			
tension load ¹⁾	20(30) ≤ d ≤ 70	10 oder 15	100	100	200	200	135	10			
			50	100							
			50	50							
shear load ^{1), 2)}				100	100	200			400	-	10
			50	100							
			50	50							

¹⁾ test sketches see Figure 4 to Figure 6

²⁾ the anchors are to be tested with the maximum possible distance (stand-off fixing)

³⁾ for sandstone and limestone: slab thickness d ≥ 30 mm

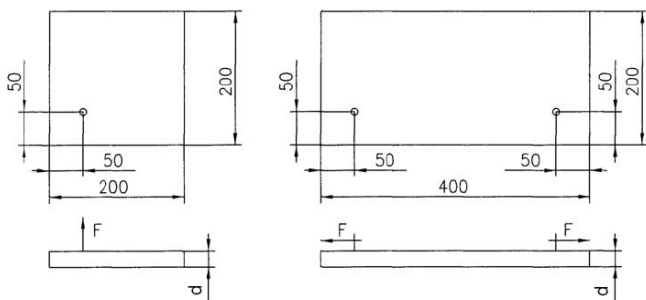

Figure 4: tension test or shear test for an edge distance 50 / 50 mm

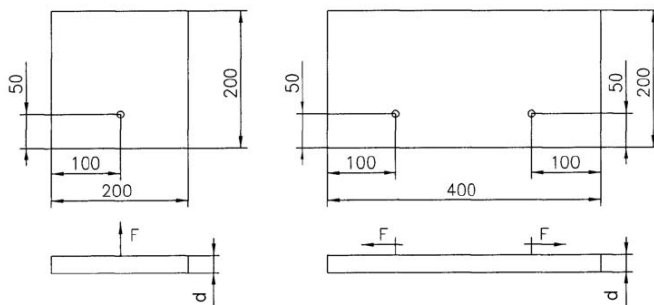

Figure 5: tension test or shear test for an edge distance 50 / 100 mm

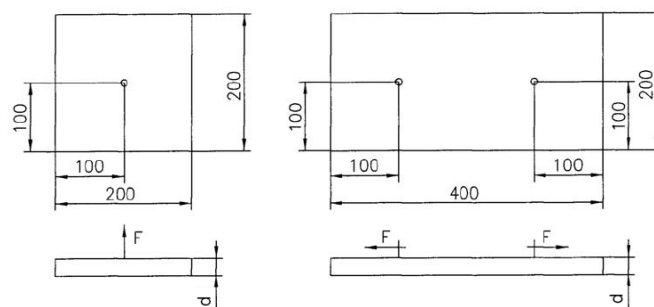

Figure 6: tension test or shear test for an edge distance 100 / 100 mm

KEIL undercut anchor KH

Determination of the characteristic values of material

Annex 10

III Design method

1 General

1.1 System assumptions

It shall be distinguished between a uniform and a non-uniform bearing.

The geometrical symmetrical execution signifies for example the configuration analogous to Annex 8. If additionally to the geometrical symmetrical execution uniform horizontal or vertical profiles are used, it can be deemed to be a uniform bearing.

In principle a uniform bearing is present if at least one of the cases applies according to Table 5.

If none of the cases listed in Table 5 applies, it shall be deemed to be a non-uniform bearing, unless proven that the redistribution of the anchor forces falls below the limit value of 15%.

Table 5: Criteria for uniform bearing

Case 1	$C_1 = C_3$ and $C_2 = C_4$
Case 2	$C_1 = C_2$ and $C_3 = C_4$

C_i = spring stiffness of the substructure (see Figure 7)

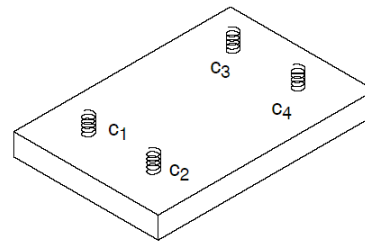

Figure 7: structural model of bearing

1.2 Safety concept

The design values of the actions shall be calculated on basis of EN 1990 in consideration of the existing loads. The combinations of actions shall be equal to EN 1990. The actions shall be specified according to EN 1991-1-1 to EN 1991-1-7. Corresponding national regulations shall be take into consideration. The unfavourable combination is decisive. Where necessary for the design of the anchor and the façade panel several combinations shall be analysed separately.

The typical fundamental combination for façade panels considers actions from dead load $F_{Sk,G}$ (permanent action), wind $F_{Sk,w}$ (leading variable action) and from mounting restraint $F_{Sk,Zw}$ (permanent load towards the anchor axis).

According to EN 1990 the following fundamental combination depending on the load direction results for a vertical façade panel:

Fundamental combination for loads parallel to the panel:

$$F_{Sd||} = F_{Sk,G} \cdot \gamma_G$$

Fundamental combination for loads perpendicular to the panel:

$$F_{Sd\perp} = F_{Sk,w} \cdot \gamma_Q + F_{Sk,Zw} \cdot \gamma_G$$

$$\text{with } \gamma_G = 1.35; \gamma_Q = 1.50$$

For hanging panels (overhead mounting) or reveal panels respectively the load direction shall be taken into consideration and the combinations of actions shall be based on EN 1990.

For mounting restraint a load of $F_{Sk,Zw} = 0.1$ kN shall be applied. National regulations shall be taken into consideration.

The design values of the actions shall be compared with the design values of the resistance. The regulations according to Section 2.3 and 3.4 shall be observed.

KEIL undercut anchor KH

Design method

Annex 11

2 Anchor design

2.1 Determination of the anchor loads at the fixing points of the façade panel

The determination of the anchor loads depends on the type of bearing of the façade panel. The anchor loads are to be determined for each fixing point from the load proportions wind and dead load¹ of the façade panel as well as from the load proportions wind and dead load of the reveal panel.

In case of uniform bearing the determination of the anchor loads shall be based on a 4-point-fixing with two load-bearing anchors (for dead loads). Additionally a mounting restraint of $F_{Sk,Zw} = 0.1$ kN as tensile load shall be taken into account for a load-bearing anchor.

In case of a non-uniform bearing the determination of the anchor loads shall be based on a 3-point-fixing with two load-bearing anchors.

2.2 Determination of the anchor loads on the fixing points of reveal angle

The anchor loads at the reveal angle are to be determined from the load proportions wind and dead load of the reveal panel.

Additionally the load proportion from strain caused by a temperature difference of ± 35 K between the façade panel and the reveal panel shall be taken into account. Unless the cross tension stiffness of the reveal angle is not proven for the verification of the temperature load the cross tension stiffness can be simplified to $c_q = 1.2$ MN/m, if the limit dimension of the angle size is observed according to Table 6:

Table 6: Limit dimension of the angle dimensions

		stainless steel	aluminium
angle thickness	t [mm]	$t \leq 6$	$t \leq 8.5$
angle width	a [mm]	$a \leq 80$	$a \leq 80$

Note:

If the anchors are installed with an edge distance $40 \text{ mm} \leq a_r < 50 \text{ mm}$, the characteristic load-bearing capacity for tension load shall be reduced by the factor 0.9.

¹ The dead load of the façade and reveal plates for relevant material is to be determined from the density according to EN 1936 taking into account the water absorption under atmospheric pressure according to EN 13755.

KEIL undercut anchor KH

Design method

Annex 12

2.3 Verification of the anchor loads

For the determined anchor loads (sections 2.1 and 2.2) it shall be proofed, that equations (1) and (2) are observed. In case of coincident stress of an anchor due to tension and shear load equation (3) shall be observed additionally:

tension load / compression load:
$$\frac{N_{Z,Sd}}{N_{Z,Rd}} \leq 1.0 \quad (1)$$

shear load:
$$\frac{V_{Sd}}{V_{Rd}} \leq 1.0 \quad (2)$$

interaction diagonal tension:
$$\frac{N_{Z,Sd}}{N_{Z,Rd}} + \frac{V_{Sd}}{V_{Rd}} \leq 1.2 \quad (3)$$

mit: N_{Sd} = design value of existing anchor tension load / compression load

V_{Sd} = design value of existing anchor shear load

N_{Rd} = design value of anchor load-bearing capacity

for tension load ²: $N_{Rd} = N_{Rk} / \gamma_M$

for compression load: $N_{Rd} = -k \cdot N_{Rk} / \gamma_M$

with: N_{Rk} according to Annex 4, Table 2

γ_M according to Annex 4, Table 2

$k = 0.8$ for $R \leq h_s$

or

1.0 for $R > h_s$

V_{Rd} = design value of anchor load-bearing capacity

for shear load: $V_{Rd} = V_{Rk} / \gamma_M$

with: V_{Rk} according to Annex 4, Table 2

γ_M according to Annex 4, Table 2

² Special case reveal panel: If the anchors are installed with an edge distance $40 \text{ mm} \leq a, < 50 \text{ mm}$, the characteristic load-bearing capacity for tension load shall be reduced by the factor 0.9.

KEIL undercut anchor KH	Annex 13
Design method	

3 Design of façade panel

3.1 Determination of decisive bending moment in the façade panel

The determination of bending moments depends on the type of bearing of the façade panel. In case of uniform bearing the decisive bending moment shall be calculated according to equation (4a) and in case of non-uniform bearing it shall be calculated according to equation (4b). For the decisive bending moment the wind load, dead load and mounting restraint of the façade panel are to be taken into account. In case of façade panel with reveal panels the wind load and dead load of the reveal panels shall be taken into account.

The decisive bending moment results from

$$\text{in case of uniform bearing:} \quad m_{Sd} = (m_{S_{k,w}} + m_{S_{k,wL}}) \cdot \gamma_F + (m_{S_{k,gL}} + m_{S_{k,Zw}}) \cdot \gamma_G \quad (4a)$$

$$\text{in case of non-uniform bearing:} \quad m_{Sd} = (m_{S_{k,w}} + m_{S_{k,wL}}) \cdot \gamma_F + m_{S_{k,gL}} \cdot \gamma_G \quad (4b)$$

with:

- $m_{S_{k,w}}$ = moments proportion from wind load (see section 3.1.1)
- $m_{S_{k,Zw}}$ = moments proportion from mounting restraint (see section 3.1.2)
- $m_{S_{k,gL}}$ = moments proportion from dead load reveal (see section 3.1.3)
- $m_{S_{k,wL}}$ = moments proportion from wind load reveal (see section 3.1.4)

3.1.1 Moments proportion from wind load

The moments proportions from wind load may be determined according to equation (5a) or (5b).

$$\text{in case of uniform bearing:} \quad m_{S_{k,w}} = \alpha_{1a} \cdot w \cdot L \cdot H \quad (5a)$$

$$\text{in case of non-uniform bearing:} \quad m_{S_{k,w}} = \alpha_{1a} \cdot w \cdot L \cdot H \quad (5b)$$

with:

- α_{1a} = moments coefficient according to Annex 17, chart 1
- α_{1b} = moments coefficient according to Annex 17, chart 2
- w = wind surface load
- L = panel length (horizontal direction) of the façade panel
- H = panel height (vertical direction) of the façade panel

3.1.2 Moments proportion from mounting restraint (in case of uniform bearing only)

The moments proportions from restraint may be determined according to equation (6).

$$m_{S_{k,Zw}} = \alpha_2 \cdot F_{S_{k,Zw}} \quad (6)$$

with:

- α_2 = moments coefficient according to Annex 17, chart 3
- $F_{S_{k,Zw}}$ = 0.1 kN = load from mounting restraint

KEIL undercut anchor KH	Annex 14
Design method	

3.1.3 Moments proportion from dead load of reveal panels

in case of uniform bearing:
$$m_{Sk,gL} = \alpha_{3a} \cdot \frac{\rho \cdot B_L \cdot d_L \cdot (B_L + d_F)}{1.2} \quad (7a)$$

in case of non-uniform bearing:
$$m_{Sk,gL} = \alpha_{3b} \cdot \frac{\rho \cdot B_L \cdot d_L \cdot (B_L + d_F)}{1.2} \quad (7b)$$

with:
$$\alpha_{3a} = 0.67 + 0.035 \cdot \frac{H}{L}$$

$$\alpha_{3b} = 0.67 + 0.045 \cdot \frac{H}{L}$$

L = panel length (horizontal direction) of the façade panel

H = panel height (vertical direction) of the façade panel

ρ = the density according to EN 1936 taking into account the water absorption under atmospheric pressure according to EN 13755

B_L = width of reveal panel (horizontal direction)

d_L = thickness of reveal panel

d_F = thickness of façade panel

Special case lintel reveal:

For lintel reveals the moments proportion from dead load is not applicable (that shall be taken into account by an increase factor for determining the moments proportion from wind load of the reveal panels, acc. to section 3.1.4).

3.1.4 Moments proportion from wind load of reveal panels

in case of uniform bearing:
$$m_{Sk,wL} = \alpha_{4a} \cdot \frac{w \cdot B_L \cdot (B_L + d_F)}{2} \quad (8a)$$

in case of non-uniform bearing:
$$m_{Sk,wL} = \alpha_{4b} \cdot \frac{w \cdot B_L \cdot (B_L + d_F)}{2} \quad (8b)$$

with:
$$\alpha_{4a} = 1.2 + 0.3 \cdot \left(\frac{H}{L}\right)^{1.5}$$

$$\alpha_{4b} = 1.7 + 0.5 \cdot \frac{H}{L}$$

L = panel length (horizontal direction) of the façade panel

H = panel height (vertical direction) of the façade panel

w = wind surface load

B_L = width of reveal panel (horizontal direction)

d_F = thickness of façade panel

KEIL undercut anchor KH

Design method

Annex 15

Special case lintel reveal:

The dead loads and wind loads act perpendicular to the panel surface. As simplified model the wind load is increased by 1.4 times the dead load. The bending moment component $m_{Sk,WL}$ is calculated according to the equation (8c) or (8d) as follows:

in case of uniform bearing:
$$m_{Sk,WL} = \alpha_{4a} \cdot \frac{w \cdot B_L \cdot (B_L + d_F)}{2} + \alpha_{4a} \cdot 1.4 \cdot \frac{d_L \cdot \rho \cdot B_L \cdot (B_L + d_F)}{2} \quad (8c)$$

in case of non-uniform bearing:
$$m_{Sk,WL} = \alpha_{4b} \cdot \frac{w \cdot B_L \cdot (B_L + d_F)}{2} + \alpha_{4b} \cdot 1.4 \cdot \frac{d_L \cdot \rho \cdot B_L \cdot (B_L + d_F)}{2} \quad (8d)$$

3.2 Verification against edge failure by façade panels with reveal panels

When fixing the reveal panels on the façade panel the verification against edge failure due to loads on the reveal angle shall be carried out additionally both for reveal panel and façade panel.

The decisive bending moment shall be determined according to equation (9).

$$m_{Sd} = \alpha_5 \cdot F_{Sd,L} \quad (9)$$

with: $\alpha_5 = 0.575 - 1.5 \cdot b_r \geq 0.2$
 $F_{Sd,L}$ = decisive anchor load on reveal angle
 b_r = b_{rL} or b_{rH} [m] (edge distance to reveal front according to Annex 6)

3.3 Determination of the decisive bending moment in the reveal panel

For the determination of the decisive bending moment the reveal panel shall be calculated parallel to the façade plane as a beam in bending and perpendicular to the façade plane as a cantilever.

Special case: lintel reveal

For the determination of the decisive bending moment the dead loads shall be increased by the factor 1.4.

3.4 Verification of the bending stresses

The corresponding bending stresses are to be determined from the decisive bending moments according to sections 3.1, 3.2 and 3.3 by means of equation (10).

For bending stresses it shall be verified that equation (11) is observed.

$$\sigma_{Sd} = \frac{6 \cdot m_{Sd}}{d^2} \quad (10)$$

$$\sigma_{Sd} \leq \sigma_{Rd} \quad (11)$$

with σ_{Sd} = design value of existing bending stress in the façade panel/ reveal panel
 m_{Sd} = design value of decisive bending moment according to 3.1, 3.2 or 3.3
 d = panel thickness of the façade panel or reveal panel
 σ_{Rd} = design value of bending strength
 $\sigma_{Rd} = \sigma_{Rk} / \gamma_M$
 with σ_{Rk} ; γ_M according to Annex 4, Table 2

KEIL undercut anchor KH

Design method

Annex 16

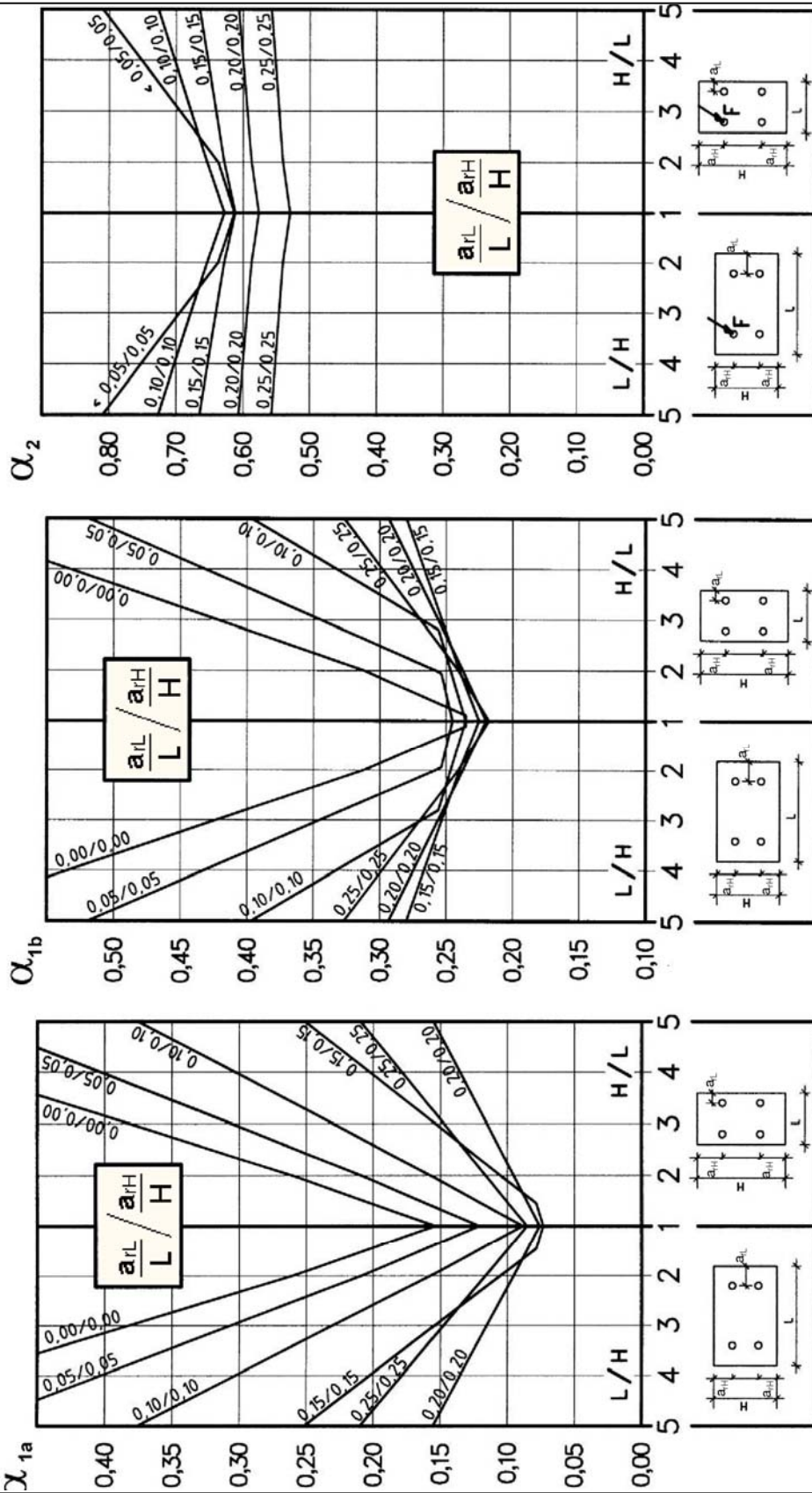

Chart 3:
moments coefficient α_2 for restraint
in case of uniform bearing

Chart 2:
moments coefficient α_{1b} for wind load in
case of non-uniform bearing

Chart 1:
moments coefficient α_{1a} for wind load in
case of uniform bearing

KEIL undercut anchor KH

Design method

Annex 17