



European Technical Approval ETA-07/0025

English translation prepared by DIBt - Original version in German language

Handelsbezeichnung <i>Trade name</i>	fischer Hochleistungsanker FH II, FH II-I <i>fischer High-Performance Anchor FH II, FH II-I</i>
Zulassungsinhaber <i>Holder of approval</i>	fischerwerke GmbH & Co. KG Weinhalde 14-18 72178 Waldachtal DEUTSCHLAND
Zulassungsgegenstand und Verwendungszweck <i>Generic type and use of construction product</i>	Kraftkontrolliert spreizender Metalldübel in den Größen 10, 12, 15, 18, 24, 28 und 32 zur Verankerung im Beton <i>Torque-controlled expansion anchor of sizes 10, 12, 15, 18, 24, 28 and 32 for use in concrete</i>
Geltungsdauer: <i>Validity:</i>	vom <i>from</i> bis <i>to</i> 4 October 2012 7 October 2016
Herstellwerk <i>Manufacturing plant</i>	fischerwerke

Diese Zulassung umfasst
This Approval contains

23 Seiten einschließlich 15 Anhänge
23 pages including 15 annexes

Diese Zulassung ersetzt
This Approval replaces

ETA-07/0025 mit Geltungsdauer vom 07.10.2011 bis 07.10.2016
ETA-07/0025 with validity from 07.10.2011 to 07.10.2016

I LEGAL BASES AND GENERAL CONDITIONS

- 1 This European technical approval is issued by Deutsches Institut für Bautechnik in accordance with:
 - Council Directive 89/106/EEC of 21 December 1988 on the approximation of laws, regulations and administrative provisions of Member States relating to construction products¹, modified by Council Directive 93/68/EEC² and Regulation (EC) N° 1882/2003 of the European Parliament and of the Council³;
 - *Gesetz über das In-Verkehr-Bringen von und den freien Warenverkehr mit Bauprodukten zur Umsetzung der Richtlinie 89/106/EWG des Rates vom 21. Dezember 1988 zur Angleichung der Rechts- und Verwaltungsvorschriften der Mitgliedstaaten über Bauprodukte und anderer Rechtsakte der Europäischen Gemeinschaften (Bauproduktengesetz - BauPG) vom 28. April 1998⁴, as amended by Article 2 of the law of 8 November 2011⁵;*
 - Common Procedural Rules for Requesting, Preparing and the Granting of European technical approvals set out in the Annex to Commission Decision 94/23/EC⁶;
 - Guideline for European technical approval of "Metal anchors for use in concrete - Part 2: Torque controlled expansion anchors ", ETAG 001-02.
- 2 Deutsches Institut für Bautechnik is authorized to check whether the provisions of this European technical approval are met. Checking may take place in the manufacturing plant. Nevertheless, the responsibility for the conformity of the products to the European technical approval and for their fitness for the intended use remains with the holder of the European technical approval.
- 3 This European technical approval is not to be transferred to manufacturers or agents of manufacturers other than those indicated on page 1, or manufacturing plants other than those indicated on page 1 of this European technical approval.
- 4 This European technical approval may be withdrawn by Deutsches Institut für Bautechnik, in particular pursuant to information by the Commission according to Article 5(1) of Council Directive 89/106/EEC.
- 5 Reproduction of this European technical approval including transmission by electronic means shall be in full. However, partial reproduction can be made with the written consent of Deutsches Institut für Bautechnik. In this case partial reproduction has to be designated as such. Texts and drawings of advertising brochures shall not contradict or misuse the European technical approval.
- 6 The European technical approval is issued by the approval body in its official language. This version corresponds fully to the version circulated within EOTA. Translations into other languages have to be designated as such.

¹ Official Journal of the European Communities L 40, 11 February 1989, p. 12

² Official Journal of the European Communities L 220, 30 August 1993, p. 1

³ Official Journal of the European Union L 284, 31 October 2003, p. 25

⁴ *Bundesgesetzblatt Teil I 1998*, p. 812

⁵ *Bundesgesetzblatt Teil I 2011*, p. 2178

⁶ Official Journal of the European Communities L 17, 20 January 1994, p. 34

II SPECIFIC CONDITIONS OF THE EUROPEAN TECHNICAL APPROVAL

1 Definition of product and intended use

1.1 Definition of the construction product

The fischer High-Performance Anchor FH II, FH II-I is an anchor made of galvanised steel (sizes with external diameter 10, 12, 15, 18, 24, 28 and 32, sizes with internal thread 12/M6 I, 12/M8 I, 15/M10 I and 15/M12 I) or stainless steel (sizes with external diameter 10, 12, 15, 18 and 24, sizes with internal thread 12/M6 I, 12/M8 I, 15/M10 I and 15/M12 I) which is placed into a drilled hole and anchored by torque-controlled expansion.

An illustration of the product and intended use is given in Annex 1 and 2.

1.2 Intended use

The anchor is intended to be used for anchorages for which requirements for mechanical resistance and stability and safety in use in the sense of the Essential Requirements 1 and 4 of Council Directive 89/106 EEC shall be fulfilled and failure of anchorages made with these products would cause risk to human life and/or lead to considerable economic consequences.

The anchor may be used for anchorages with requirements related to resistance to fire.

The anchor is to be used only for anchorages subject to static or quasi-static loading in reinforced or unreinforced normal weight concrete of strength classes C20/25 at minimum and C50/60 at most according to EN 206: 2000-12. It may be anchored in cracked and non-cracked concrete.

fischer High-Performance Anchor FH II, FH II-I made of galvanised steel:

The anchor may only be used in structures subject to dry internal conditions.

fischer High-Performance Anchor FH II, FH II-I A4 made of stainless steel:

The anchor made of stainless steel A4 may be used in structures subject to dry internal conditions and also in structures subject to external atmospheric exposure (including industrial and marine environment), or exposure in permanently damp internal conditions, if no particular aggressive conditions exist. Such particular aggressive conditions are e.g. permanent, alternating immersion in seawater or the splash zone of seawater, chloride atmosphere of indoor swimming pools or atmosphere with extreme chemical pollution (e.g. in desulphurization plants or road tunnels where de-icing materials are used).

The provisions made in this European technical approval are based on an assumed working life of the anchor of 50 years. The indications given on the working life cannot be interpreted as a guarantee given by the producer, but are to be regarded only as a means for choosing the right products in relation to the expected economically reasonable working life of the works.

2 Characteristics of the product and methods of verification

2.1 Characteristics of the product

The anchor corresponds to the drawings and provisions given in Annexes 1 to 5. The characteristic material values, dimensions and tolerances of the anchor not given in Annexes 1 to 4 shall correspond to the respective values laid down in the technical documentation⁷ of this European technical approval.

Regarding the requirements concerning safety in case of fire it is assumed that the anchor meets the requirements of class A1 in relation to reaction to fire in accordance with the stipulations of the Commission decision 96/603/EC, amended by 2000/605/EC.

The characteristic values for the design of anchorages are given in Annexes 6 to 11.

The characteristic values for the design of anchorages regarding resistance to fire are given in Annexes 12 and 13. They are valid for use in a system that is required to provide a specific fire resistance class.

Each anchor is marked according to Annex 1 and 2.

The anchor shall only be supplied as a complete unit.

2.2 Methods of verification

The assessment of fitness of the anchor for the intended use in relation to the requirements for mechanical resistance and stability and safety in use in the sense of the Essential Requirements 1 and 4 has been made in accordance with the "Guideline for European technical approval of Metal Anchors for Use in Concrete", Part 1 "Anchors in general" and Part 2 "Torque-controlled expansion anchors", on the basis of Option 1.

The assessment of the anchor for the intended use in relation to the requirements for resistance to fire has been made in accordance with the Technical Report TR 020 "Evaluation of anchorages in concrete concerning resistance to fire".

In addition to the specific clauses relating to dangerous substances contained in this European technical approval, there may be other requirements applicable to the products falling within its scope (e.g. transposed European legislation and national laws, regulations and administrative provisions). In order to meet the provisions of the Construction Products Directive, these requirements need also to be complied with, when and where they apply.

3 Evaluation and attestation of conformity and CE marking

3.1 System of attestation of conformity

According to the decision 96/582/EG of the European Commission⁸ the system 2(i) (referred to as system 1) of attestation of conformity applies.

This system of attestation of conformity is defined as follows:

⁷ The technical documentation of this European technical approval is deposited at the Deutsches Institut für Bautechnik and, as far as relevant for the tasks of the approved bodies involved in the attestation of conformity procedure, is handed over to the approved bodies.

⁸ Official Journal of the European Communities L 254 of 08.10.1996.

System 1: Certification of the conformity of the product by an approved certification body on the basis of:

- (a) Tasks for the manufacturer:
 - (1) factory production control;
 - (2) further testing of samples taken at the factory by the manufacturer in accordance with a prescribed control plan;
- (b) Tasks for the approved body:
 - (3) initial type-testing of the product;
 - (4) initial inspection of factory and of factory production control;
 - (5) continuous surveillance, assessment and approval of factory production control.

Note: Approved bodies are also referred to as "notified bodies".

3.2 Responsibilities

3.2.1 Tasks of the manufacturer

3.2.1.1 Factory production control

The manufacturer shall exercise permanent internal control of production. All the elements, requirements and provisions adopted by the manufacturer shall be documented in a systematic manner in the form of written policies and procedures, including records of results performed. This production control system shall insure that the product is in conformity with this European technical approval.

The manufacturer may only use initial/ raw/ constituent materials stated in the technical documentation of this European technical approval.

The factory production control shall be in accordance with the control plan which is part of the technical documentation of this European technical approval. The control plan is laid down in the context of the factory production control system operated by the manufacturer and deposited at Deutsches Institut für Bautechnik⁹.

The results of factory production control shall be recorded and evaluated in accordance with the provisions of the control plan.

3.2.1.2 Other tasks of manufacturer

The manufacturer shall, on the basis of a contract, involve a body which is approved for the tasks referred to in section 3.1 in the field of anchors in order to undertake the actions laid down in section 3.2.2. For this purpose, the control plan referred to in sections 3.2.1.1 and 3.2.2 shall be handed over by the manufacturer to the approved body involved.

The manufacturer shall make a declaration of conformity, stating that the construction product is in conformity with the provisions of this European technical approval.

3.2.2 Tasks of approved bodies

The approved body shall perform the

- initial type-testing of the product ,
 - initial inspection of factory and of factory production control,
 - continuous surveillance, assessment and approval of factory production control,
- in accordance with the provisions laid down in the control plan.

The approved body shall retain the essential points of its actions referred to above and state the results obtained and conclusions drawn in a written report.

⁹ The control plan is a confidential part of the documentation of the European technical approval, but not published together with the ETA and only handed over to the approved body involved in the procedure of attestation of conformity. See section 3.2.2.

The approved certification body involved by the manufacturer shall issue an EC certificate of conformity of the product stating the conformity with the provisions of this European technical approval.

In cases where the provisions of the European technical approval and its control plan are no longer fulfilled the certification body shall withdraw the certificate of conformity and inform Deutsches Institut für Bautechnik without delay.

3.3 CE marking

The CE marking shall be affixed on each packaging of the anchor. The letters "CE" shall be followed by the identification number of the approved certification body, where relevant, and be accompanied by the following additional information:

- The name and address of the producer (legal entity responsible for the manufacturer),
- The last two digits of the year in which the CE marking was affixed,
- The number of the EC certificate of conformity for the product,
- The number of the European technical approval,
- The number of the guideline for European technical approval,
- Use category (ETAG 001-1 Option 1),
- Size.

4 Assumptions under which the fitness of the product for the intended use was favourably assessed

4.1 Manufacturing

The European technical approval is issued for the product on the basis of agreed data/information, deposited with Deutsches Institut für Bautechnik, which identifies the product that has been assessed and judged. Changes to the product or production process, which could result in this deposited data/information being incorrect, should be notified to Deutsches Institut für Bautechnik before the changes are introduced. Deutsches Institut für Bautechnik will decide whether or not such changes affect the approval and consequently the validity of the CE marking on the basis of the approval and if so whether further assessment or alterations to the approval shall be necessary.

4.2 Design of anchorages

The fitness of the anchor for the intended use is given under the following conditions:

The anchorages are designed in accordance with the "Guideline for European technical approval of Metal Anchors for Use in Concrete", Annex C, Method A under the responsibility of an engineer experienced in anchorages and concrete work.

Verifiable calculation notes and drawings are taking account of the loads to be anchored.

The position of the anchor is indicated on the design drawings (e.g. position of the anchor relative to reinforcement or to supports).

The minimum strength class and the minimum screwing depth of the fastening screw or threaded rod for installation of the fixture shall meet the requirements according to Annex 5. The length of the fastening screw or threaded rod shall be defined according to the available thread length, the minimum screwing depth, the thickness of fixture and tolerances of member and fixture.

The design of anchorages under fire exposure has to consider the conditions given in the Technical Report TR 020 "Evaluation of anchorages in concrete concerning resistance to fire". The relevant characteristic anchor values are given in Annexes 12 and 13. The design method covers anchors with a fire attack from one side only. If the fire attack is from more than one side, the design method may be taken only, if the edge distance of the anchor is $c \geq 300$ mm.

4.3 Installation of anchors

The fitness for use of the anchor can only be assumed if the anchor is installed as follows:

- Anchor installation carried out by appropriately qualified personnel and under the supervision of the person responsible for technical matters of the site,
- Use of the anchor only as supplied by the manufacturer without exchanging the components of an anchor,
- For anchor version FH II-I the commercial standard rod may only be used if the following requirements are fulfilled:
 - material, dimensions and mechanical properties of the metal parts according to the specifications given in Annex 7, Table 5,
 - confirmation of material and mechanical properties of the metal parts by inspection certificate 3.1 according to EN 10204:2004, the documents should be stored,
- Anchor installation in accordance with the manufacturer's specifications and drawings and using the appropriate tools,
- Checks before placing the anchor to ensure that the strength class of the concrete in which the anchor is to be placed is in the range given and is not lower than that of the concrete to which the characteristic loads apply,
- Check of concrete being well compacted, e.g. without significant voids,
- Edge distances and spacing not less than the specified values without minus tolerances.
- Positioning of the drill holes without damaging the reinforcement,
- In case of aborted hole: new drilling at a minimum distance away of twice the depth of the aborted hole or smaller distance if the aborted drill hole is filled with high strength mortar and if under shear or oblique tension load it is not in the direction of load application,
- Cleaning of the hole of drilling dust,
- Anchor installation such that the effective anchorage depth is complied with. This compliance is ensured when the embedment mark of the anchor does no more exceed the concrete surface,
- For anchor version FH II application of the torque moment T_{inst} given in Annex 4 using a calibrated torque wrench.
- Control of appropriate setting of anchors with internal thread FH II-I by either
 - Application of the installation torque T_{inst} given in Annex 5 using a calibrated torque wrench or
 - checking the distance between anchor sleeve and concrete surface U acc. to Annex 15 Figure 4.).
- For anchors with internal thread FH II-I the torque moment on fixing elements (screws or threaded rods with washer and nut) shall not exceed the maximum torque moment T_{max} given in Annex 5.

5 Responsibility of the manufacturer

The manufacturer is responsible to ensure that the information on the specific conditions according to 1 and 2 including Annexes referred to as well as sections 4.2 and 4.3 is given to those who are concerned. This information may be made by reproduction of the respective parts of the European technical approval. In addition all installation data shall be shown clearly on the package and/or on an enclosed instruction sheet, preferably using illustration(s).

The minimum data required are:

- Diameter of drill bit,
- Thread diameter,
- Maximum thickness of the fixture,
- Minimum effective anchorage depth,
- Minimum hole depth,
- Torque moment,
- Information on the installation procedure, including cleaning of the hole, preferably by means of an illustration,
- Reference to any special installation equipment needed,
- Identification of the manufacturing batch.

All data shall be presented in a clear and explicit form.

Andreas Kummerow
p. p. Head of Department

beglaubigt:
Baderschneider

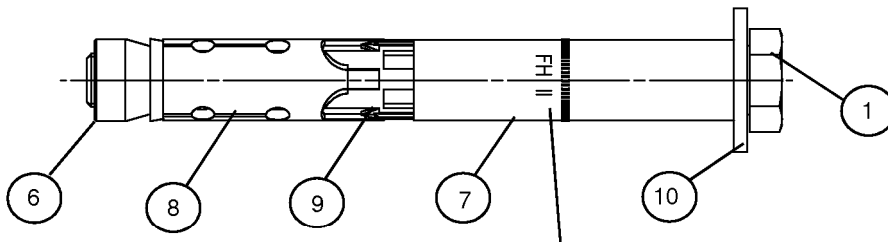

Type hexagon screw S
FH II 10 - 32 S
FH II 10 - 24 S A4

Marking: Identifying mark of the producer, anchor identity
nominal drill hole diameter / max. thickness of fixture
e. g. FH II 15/25 A4

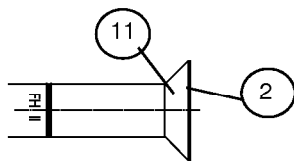

Type countersunk screw SK
FH II 10 - 18 SK
FH II 10 - 18 SK A4

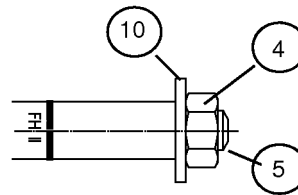

Type hexagon nut B
FH II 10 - 32 B
FH II 10 - 24 B A4

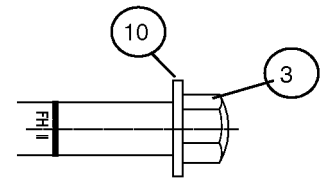

Type cap nut H
FH II 10 - 24 H
FH II 10 - 24 H A4

- ① Hexagon screw
- ② Countersunk screw
- ③ Cap nut
- ④ Hexagon nut
- ⑤ Threaded rod
- ⑥ Cone nut
- ⑦ Distance sleeve
- ⑧ Expansion sleeve
- ⑨ Plastic sleeve
- ⑩ Washer
- ⑪ Conical washer

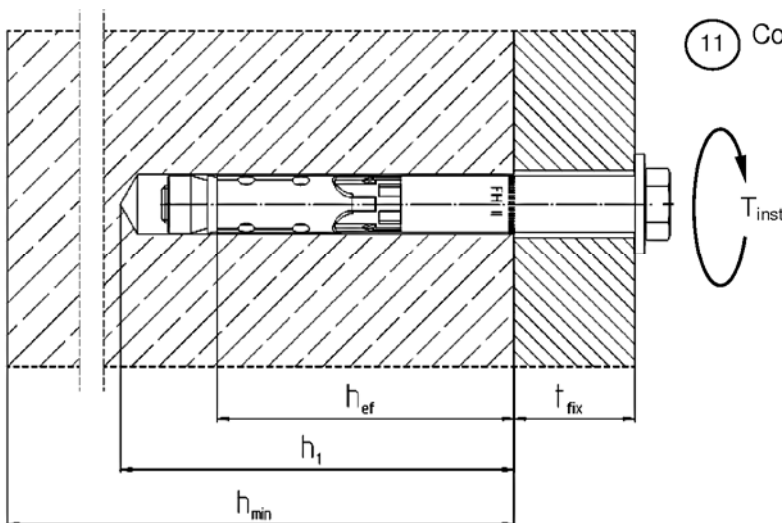

h_{ef} : effective anchorage depth.
 t_{fix} : thickness of fixture.
 h_1 : drill hole depth.
 h_{min} : minimal member thickness.
 T_{inst} : installation torque.

fischer High-Performance Anchor FH II, FH II-I

Product and Intended use FH II and FH II A4

Annex 1

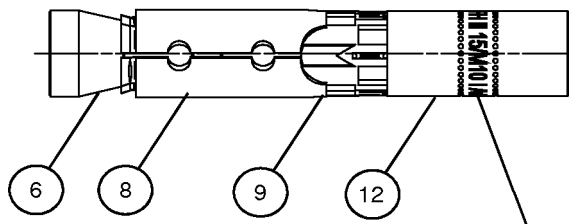

- 6 Cone nut
- 8 Expansion sleeve
- 9 Plastic sleeve
- 12 Internal thread bolt

Marking: Identifying mark of the producer, anchor identity nominal drill hole diameter / size of internal thread e. g.  FH II 15/M12 I A4

- FH II 12 M6 I (A4)
- FH II 12 M8 I (A4)
- FH II 15 M10 I (A4)
- FH II 15 M12 I (A4)

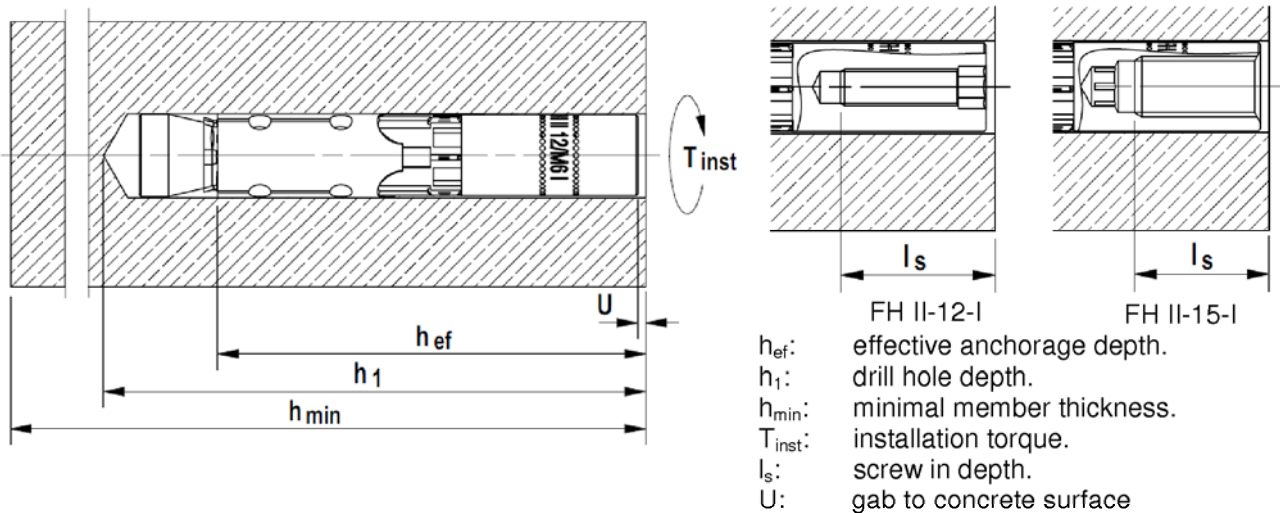

Example of possible Applications FH II-I and FH II-I A4

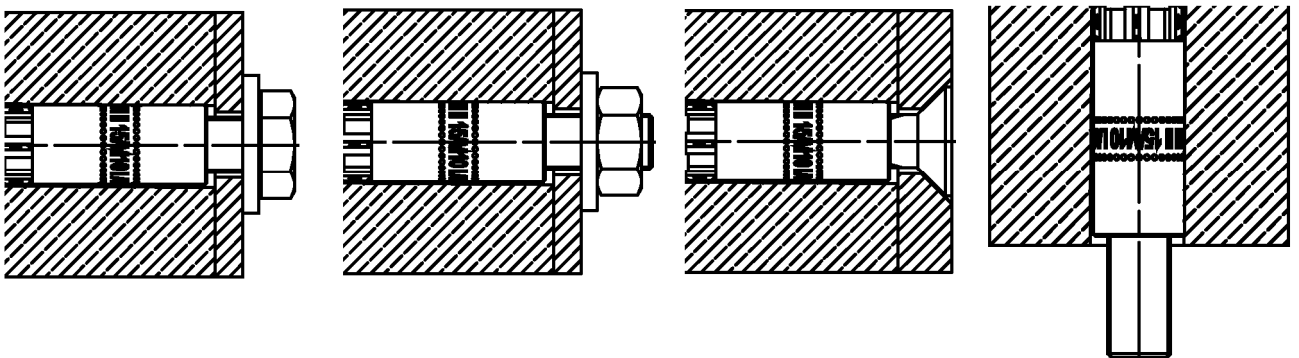

fischer High-Performance Anchor FH II, FH II-I

Product and Intended use FH II-I and FH II-I A4

Annex 2

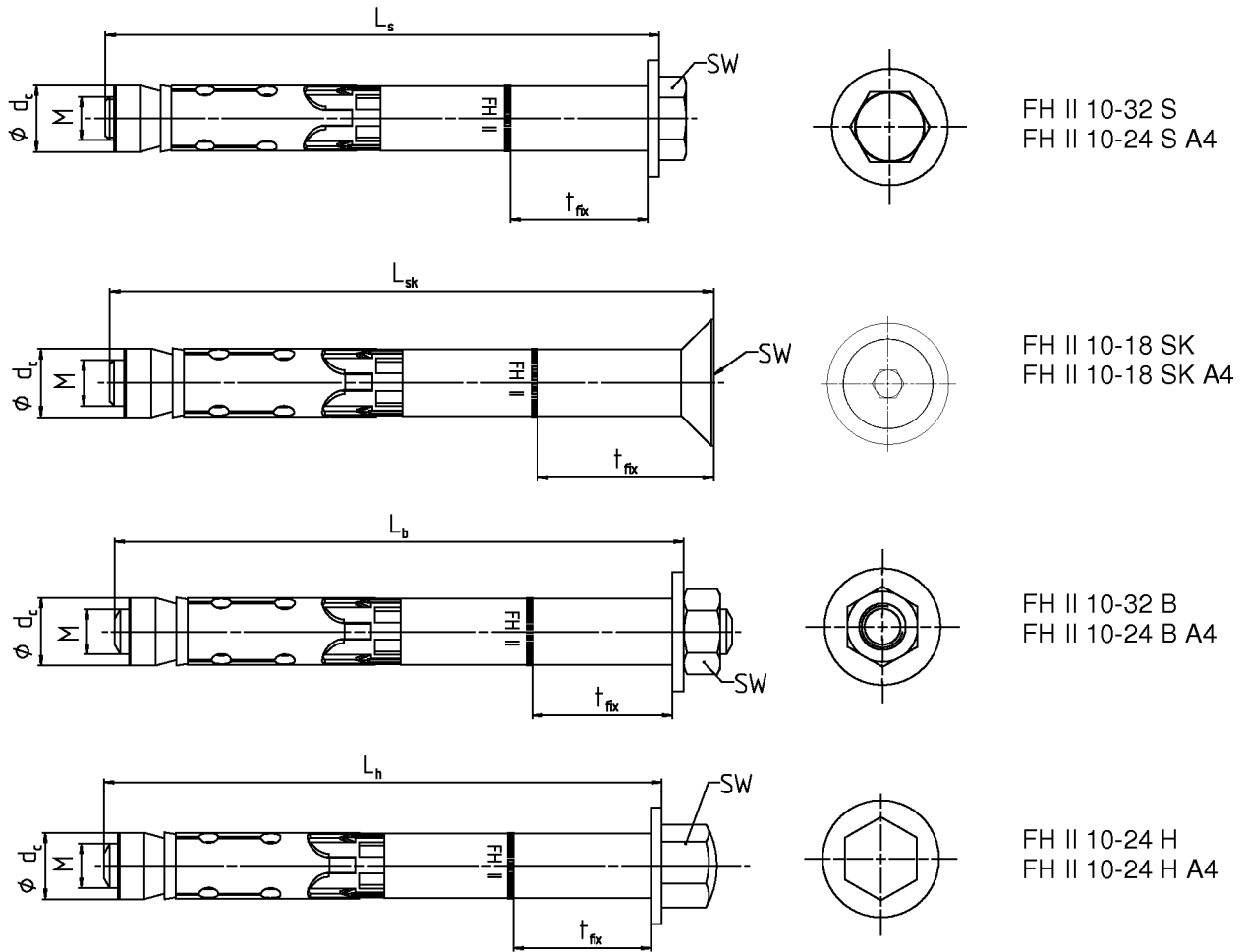

Table 1: Anchor Dimensions [mm] FH II and FH II A4

Anchor type FH II S, SK, B, H and FH II S, SK, B, H A4			FH II 10	FH II 12	FH II 15	FH II 18	FH II 24	FH II 28	FH II 32
thread	M	=	6	8	10	12	16	20	24
diameter conical nut	d _c	=	10	12	14,8	17,8	23,7	27,5	31,5
Wrench size SW FH II	FH II S, B	=	10	13	17	19	24	30	36
	FH II SK ¹⁾		4	5	6	8	-	-	-
	FH II H		13	17	17	19	24	-	-
Wrench size SW FH II A4	FH II S, B, H A4	=	10	13	17	19	24	-	-
	FH II SK A4 ¹⁾		4	5	6	8	-	-	-
t _{fix} FH II + FH II A4 S, B, H	min		0	0	0	0	0	0	0
t _{fix} FH II SK + FH II SK A4 ²⁾	min		10	10	15	15	-	-	-
t _{fix} FH II + FH II A4	max		250	250	300	350	400	500	500
length of screw / bolt	L _s , L _h , L _b (- t _{fix})	≥	49	74	89	99	124	149	174
length of countersunk screw	L _{sk} (- t _{fix})	≥	54	79	95	107	-	-	-

¹⁾ internal hexagon

²⁾ Minimum thickness of fixture

fischer High-Performance Anchor FH II, FH II-I

Anchor types, anchor dimensions
FH II and FH II A4

Annex 3

Table 2: Material FH II and FH II A4

Nb.	Designation	FH II	FH II A4
1	Hexagon screw	Steel class 8.8; DIN EN ISO 898-1 ¹⁾	Strength class 70 DIN EN ISO 3506
2	Countersunk screw	Steel class 8.8; DIN EN ISO 898-1 ¹⁾	
3	Cap nut	Steel class 8 ¹⁾	
4	Hexagon nut	Steel class 8 ¹⁾	
5	Threaded rod	Steel $f_{uk} \geq 800 \text{ N/mm}^2$; $f_{yk} \geq 640 \text{ N/mm}^2$ ¹⁾	
6	Cone nut	Steel EN 10277 ¹⁾	
7	Distance sleeve	Steel EN 10305 ¹⁾	EN 10088
8	Expansion sleeve	Steel EN 10139 / EN 10277 ¹⁾	EN 10088
9	Plastic sleeve	ABS (plastic)	
10	Washer	Steel EN 10139 ¹⁾	EN 10088
11	Conical washer	Steel EN 10277 ¹⁾	EN 10088

¹⁾ Galvanised according to EN ISO 4042, $\geq 5 \mu\text{m}$

Table 3: Installation parameters FH II and FH II A4

Anchor type FH II S, SK, B, H and FH II S, SK, B, H A4	FH II 10	FH II 12	FH II 15	FH II 18	FH II 24	FH II 28	FH II 32	
Nominal drill hole Diameter $d_0 = [\text{mm}]$	10	12	15	18	24	28	32	
Maximum diameter of drill bit $d_{out} \leq [\text{mm}]$	10,45	12,50	15,50	18,50	24,55	28,55	32,70	
Depth of drill hole $h_1 \geq [\text{mm}]$	55	80	90	105	125	155	180	
Diameter of clearance hole $d_f \leq [\text{mm}]$	12	14	17	20	26	31	35	
Diameter of counter sunk FH II SK	18	22	25	32	-	-	-	
Depth of counter sunk, 90° FH II SK A4	5,0	5,8	5,8	8,0	-	-	-	
Required installation torque $T_{inst} = [\text{Nm}]$	FH II S	10	22,5	40	80	160	180	200
	FH II B	10	17,5	38	80	120	180	200
	FH II H	10	22,5	40	80	90	-	-
	FH II SK	10	22,5	40	80	-	-	-
	FH II S, B, H A4	15	25	40	100	160	-	-
	FH II SK A4	10	25	40	100	-	-	-

fischer High-Performance Anchor FH II, FH II-I

Materials / Installation instruction FH II and FH II A4

Annex 4

Table 4: Anchor Dimensions [mm] FH II-I and FH II-I A4

Anchor type FH II-I and FH II-I A4			FH II 12/M6 I	FH II 12/M8 I	FH II 15/M10 I	FH II 15/M12 I
thread	M	=	6	8	10	12
diameter conical nut	d_c	=	12	12	14,8	14,8
Wrench size internal hexagon		=	6	8	6	8
anchor length	L	=	77,5	77,5	90	90

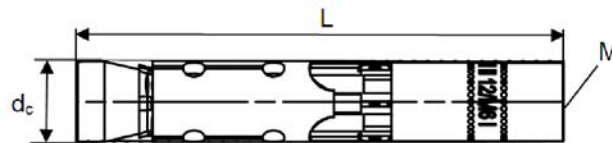

Table 5: Material FH II-I and FH II-I A4

Nb.	Designation	FH II-I	FH II-I A4
6	Cone nut	Steel EN 10277 ¹⁾	Strength class 70 DIN EN ISO 3506
8	Expansion sleeve	Steel EN 10139 / EN 10277 ¹⁾	EN 10088
9	Plastic sleeve	ABS (plastic)	
12	Internal thread bolt	Steel EN 10277 ¹⁾ $f_{uk} \geq 750 \text{ N/mm}^2$, $f_{yk} \geq 600 \text{ N/mm}^2$	EN 10088 $f_{uk} \geq 750 \text{ N/mm}^2$, $f_{yk} \geq 600 \text{ N/mm}^2$
Requirements for fixing elements		Steel strength class 5.8, 6.8 or 8.8 DIN EN ISO 898-1 ¹⁾	Steel strength class A50, A70 or A80 DIN EN ISO 3506 1.4362, 1.4401, 1.4404, 1.4571, 1.4529

¹⁾ Galvanised according to EN ISO 4042, $\geq 5 \mu\text{m}$

Table 6: Installation parameters FH II-I and FH II-I A4

Anchor type FH II-I and FH II-I A4	FH II 12/M6 I	FH II 12/M8 I	FH II 15/M10 I	FH II 15/M12 I
Nominal drill hole Diameter $d_0 = [\text{mm}]$	12		15	
Maximum diameter of drill bit $d_{cut} \leq [\text{mm}]$	12,50		15,50	
Depth of drill hole $h_1 \geq [\text{mm}]$	85		95	
Diameter of clearance hole $d_f \leq [\text{mm}]$	7	9	12	14
Required gap after torquing ¹⁾ $U = [\text{mm}]$	3-5 mm			
Required installation torque ¹⁾ $T_{inst} = [\text{Nm}]$	15		25	
Minimum screw in length $l_s \geq [\text{mm}]$	11+U	13+U	10+U	12+U
Maximum screw in length $l_s \leq [\text{mm}]$	20+U			
Maximum torque on fixture in combination with screws and threaded rods strength class ≥ 5.8 and $\geq A50$ $T_{max} \leq [\text{Nm}]$	3	8	15	20

¹⁾ Only one of both requirements has to be fulfilled.

fischer High-Performance Anchor FH II, FH II-I

Anchor dimensions / Materials / Installation instructions
FH II-I and FH II-I A4

Annex 5

Table 7: Minimum thickness of concrete member, min. spacing and min. edge distances
FH II, FH II A4

Anchor type FH II S, SK, B, H and FH II S, SK, B, H A4		FH II 10	FH II 12	FH II 15	FH II 18	FH II 24	FH II 28	FH II 32
Min. member thickness	h_{min} [mm]	80	120	140	160	200	250	300
Minimum spacing, cracked concrete	s_{min} [mm]	40	50	60	70	80	100	120
	für $c \geq$ [mm]	40	80	120	140	180	200	260
Minimum edge distance, cracked concrete	c_{min} [mm]	40	50	60	70	80	100	120
	für $s \geq$ [mm]	40	80	120	160	200	220	280
Minimum spacing, uncracked concrete	s_{min} [mm]	40	60	70	80	100	120	160
	für $c \geq$ [mm]	70	100	100	160	200	220	360
Minimum edge distance, uncracked concrete	c_{min} [mm]	40	60	70	80	100	120	180
	für $s \geq$ [mm]	70	100	140	200	220	240	380

Intermediate values may be calculated by linear interpolation.

Table 8: Minimum thickness of concrete member, min. spacing and min. edge distances
FH II-I, FH II-I A4

Anchor type FH II-I and FH II-I A4		FH II 12/M6 I FH II 12/M8 I	FH II 15/M10 I FH II 15/M12 I
Min. member thickness	h_{min} [mm]	125	150
Minimum spacing, cracked concrete	s_{min} [mm]	50	60
	für $c \geq$ [mm]	80	120
Minimum edge distance, cracked concrete	c_{min} [mm]	50	60
	für $s \geq$ [mm]	80	120
Minimum spacing, uncracked concrete	s_{min} [mm]	60	70
	für $c \geq$ [mm]	100	100
Minimum edge distance, uncracked concrete	c_{min} [mm]	60	70
	für $s \geq$ [mm]	100	140

Intermediate values may be calculated by linear interpolation.

fischer High-Performance Anchor FH II, FH II-I

Member dimensions FH II, FH II A4 and FH II-I, FH II-I A4

Annex 6

Table 9: Design method A - according to ETAG 001, Annex C
characteristic values for tension loads. FH II and FH II A4

Anchor type FH II S, SK, B, H and FH II S, SK, B, H A4			FH II 10	FH II 12	FH II 15	FH II 18	FH II 24	FH II 28	FH II 32
Characteristic resistance steel failure									
FH II	$N_{Rk,s}$	[kN]	16,1	29,3	46,4	67,4	125,3	195,8	282,0
FH II A4	$N_{Rk,s}$	[kN]	14,1	25,6	40,6	59,0	109,7	-	-
Partial safety factor γ_{Ms} ¹⁾			1,5						
Characteristic resistance pullout failure									
cracked concrete FH II and FH II A4	$N_{Rk,p}$	C20/25 [kN]	7,5	12	16	25	2)	2)	2)
non-cracked concrete FH II	$N_{Rk,p}$	C20/25 [kN]	2)	2)	2)	2)	2)	2)	2)
non-cracked concrete FH II A4	$N_{Rk,p}$	C20/25 [kN]	2)	20	2)	2)	2)	-	-
Increasing factors for $N_{Rk,p}$		ψ_c	C25/30						
			C30/37						
			C35/45						
			C40/50						
			C45/55						
			C50/60						
Partial safety factor γ_{Mp} ¹⁾			1,5 ³⁾						
Characteristic resistance concrete cone failure and splitting failure									
Effective anchorage depth	h_{ef}	[mm]	40	60	70	80	100	125	150
Spacing	$s_{cr,N}$	[mm]	120	180	210	240	300	375	450
Edge distance	$c_{cr,N}$	[mm]	60	90	105	120	150	187,5	225
Spacing (splitting)	$s_{cr,sp}$	[mm]	190	300	320	340	380	480	570
Edge distance (splitting)	$c_{cr,sp}$	[mm]	95	150	160	170	190	240	285
Partial safety factor γ_{Mc} ¹⁾			1,5 ³⁾						

¹⁾ In absence of other national regulations.

²⁾ Pullout failure is not decisive.

³⁾ The partial safety factor $\gamma_2 = 1,0$ is included.

Table 10: Displacements under tension loads, FH II and FH II A4

Anchor type FH II S, SK, B, H and FH II S, SK, B, H A4			FH II 10	FH II 12	FH II 15	FH II 18	FH II 24	FH II 28	FH II 32
Tension load cracked concrete	N	[kN]	3,6	5,7	7,6	11,9	17,1	24,0	31,5
Corresponding displacements	δ_{N0}	[mm]	1,0	1,0	1,0	1,0	1,0	0,7	0,7
	$\delta_{N\infty}$	[mm]	1,7	1,6	1,6	1,6	1,8	1,3	1,1
Tension load uncracked concrete	N	[kN]	6,0	11,2	14,1	17,2	24,0	33,6	44,2
Corresponding displacements	δ_{N0}	[mm]	0,6	1,0	1,0	1,0	1,0	0,3	0,3
	$\delta_{N\infty}$	[mm]	1,7	1,6	1,6	1,6	1,8	1,3	1,1

fischer High-Performance Anchor FH II, FH II-I

Design method A: Characteristic values for tension loads and displacements
FH II and FH II A4

Annex 7

Table 11: Design method A - according to ETAG 001, Annex C
characteristic values for tension loads FH II-I and FH II-I A4

Anchor type FH II-I and FH II-I A4		FH II 12/M6 I	FH II 12/M8 I	FH II 15/M10 I	FH II 15/M12 I
Characteristic resistance steel failure					
Anchor in combination with screw / threaded rod of galvanised steel complying with DIN EN ISO 898					
Strength class 5.8	$N_{Rk,s}$ [kN]	10	19	29	43
Strength class 6.8	$N_{Rk,s}$ [kN]	12	23	35	44
Strength class 8.8	$N_{Rk,s}$ [kN]	16	27	44	44
Partial safety factor	$\gamma_{Ms}^{1)}$	1,5			
Anchor in combination with screw / threaded rod of stainless steel complying with DIN EN ISO 3506					
Screw/thread strength class A50	$N_{Rk,s}$ [kN]	10	19	29	43
Partial safety factor	$\gamma_{Ms}^{1)}$	2,86			
Screw/thread strength class A70	$N_{Rk,s}$ [kN]	14	26	41	54
Partial safety factor	$\gamma_{Ms}^{1)}$	1,87			
Screw/thread strength class A80	$N_{Rk,s}$ [kN]	16	29	46	46
Partial safety factor	$\gamma_{Ms}^{1)}$	1,60			
Characteristic resistance pullout failure					
cracked concrete	$N_{Rk,p}$ [kN] C20/25	9		12	
non-cracked concrete	$N_{Rk,p}$ [kN] C20/25	20		2)	
Increasing factors for $N_{Rk,p}$	ψ_c	C25/30	1,10		
		C30/37	1,22		
		C35/45	1,34		
		C40/50	1,41		
		C45/55	1,48		
		C50/60	1,55		
Partial safety factor	$\gamma_{Mp}^{1)}$	1,5 ³⁾			
Characteristic resistance concrete cone failure and splitting failure					
Effective anchorage depth	h_{ef} [mm]	60		70	
Spacing	$s_{cr,N}$ [mm]	180		210	
Edge distance	$c_{cr,N}$ [mm]	90		105	
Spacing (splitting)	$s_{cr,sp}$ [mm]	300		320	
Edge distance (splitting)	$c_{cr,sp}$ [mm]	150		160	
Partial safety factor	$\gamma_{Mc}^{1)}$	1,5 ³⁾			

¹⁾ In absence of other national regulations.

²⁾ Pullout failure is not decisive.

³⁾ The partial safety factor $\gamma_2 = 1,0$ is included.

Table 12: Displacements under tension loads, FH II-I and FH II-I A4

Anchor type FH II-I and FH II-I A4		FH II 12/M6 I	FH II 15/M10 I
		FH II 12/M8 I	FH II 15/M12 I
Tension load cracked concrete	N [kN]	4,3	5,7
Tension load uncracked concrete		9,5	14,1
Corresponding displacements	δ_{N0} [mm]	1,7	1,9
	$\delta_{N\infty}$ [mm]	2,2	2,9

fischer High-Performance Anchor FH II, FH II-I

Design method A: Characteristic values for tension loads and displacements
FH II-I and FH II-I A4

Annex 8

Table 13: Design method A, characteristic values for shear loads

Anchor type FH II S, SK, B, H and FH II S, SK, B, H A4		FH II 10	FH II 12	FH II 15	FH II 18	FH II 24	FH II 28	FH II 32
Characteristic resistance steel failure without lever arm								
FH II S + FH II SK	$V_{Rk,s}$ [kN]	18	33	59	76	146	174	217
FH II B + FH II H	$V_{Rk,s}$ [kN]	16	27	41	62	119	146	169
FH II S A4, FH II SK A4, FH II B A4, FH II H A4	$V_{Rk,s}$ [kN]	18	28	43	66	119	-	-
Partial safety factor	γ_{Ms} ¹⁾	1,25						
Characteristic resistance steel failure with lever arm								
Bending FH II	$M^0_{Rk,s}$ [Nm]	12	30	60	105	266	518	896
Bending FH II A4	$M^0_{Rk,s}$ [Nm]	11	26	52	92	232	-	-
Partial safety factor	γ_{Ms} ¹⁾	1,25						
Characteristic resistance concrete pryout failure								
Factor in equation (5.6) of ETAG 001 Annex C, 5.2.3.3	k	1,0	2,0					
Partial safety factor	γ_{Mcp} ¹⁾	1,5 ²⁾						
Characteristic resistance concrete edge failure								
Effective length of anchor under shear load	l_f [mm]	40	60	70	80	100	125	150
Effective diameter of anchor	d_{nom} [mm]	10	12	15	18	24	28	32
Partial safety factor	γ_{Mc} ¹⁾	1,5 ²⁾						

¹⁾ In absence of other national regulations.

²⁾ The partial safety factor $\gamma_2 = 1,0$ is included.

fischer High-Performance Anchor FH II, FH II-I

Design method A
Characteristic values for shear loads FH II and FH II A4

Annex 9

Table 14: Design method A, characteristic values for shear loads

Anchor type FH II-I and FH II-I A4		FH II 12/M6 I	FH II 12/M8 I	FH II 15/M10 I	FH II 15/M12 I
Characteristic resistance steel failure without lever arm					
In combination with screw / threaded rod of galvanised steel complying with DIN EN ISO 898					
Strength class 5.8	$V_{Rk,s}$ [kN]	5	9	15	21
Strength class 6.8	$V_{Rk,s}$ [kN]	6	11	18	24
Strength class 8.8	$V_{Rk,s}$ [kN]	8	14	23	24
Partial safety factor	$\gamma_{Ms}^{1)}$	1,25			
In combination with screw / threaded rod of stainless steel complying with DIN EN ISO 3506					
Screw/thread strength class A50	$V_{Rk,s}$ [kN]	5	9	15	21
Partial safety factor	$\gamma_{Ms}^{1)}$	2,38			
Screw/thread strength class A70	$V_{Rk,s}$ [kN]	7	13	20	30
Partial safety factor	$\gamma_{Ms}^{1)}$	1,56			
Screw/thread strength class A80	$V_{Rk,s}$ [kN]	8	15	23	32
Partial safety factor	$\gamma_{Ms}^{1)}$	1,33			
Characteristic resistance steel failure with lever arm					
In combination with screw / threaded rod of galvanised steel complying with DIN EN ISO 898					
Strength class 5.8	$M^0_{Rk,s}$ [Nm]	8	19	37	65
Strength class 6.8	$M^0_{Rk,s}$ [Nm]	9	23	44	78
Strength class 8.8	$M^0_{Rk,s}$ [Nm]	12	30	60	105
Partial safety factor	$\gamma_{Ms}^{1)}$	1,25			
In combination with screw / threaded rod of stainless steel complying with DIN EN ISO 3506					
Strength class A50	$M^0_{Rk,s}$ [Nm]	8	19	37	65
Partial safety factor	$\gamma_{Ms}^{1)}$	2,38			
Strength class A70	$M^0_{Rk,s}$ [Nm]	11	26	52	92
Partial safety factor	$\gamma_{Ms}^{1)}$	1,56			
Strength class A80	$M^0_{Rk,s}$ [Nm]	12	30	60	105
Partial safety factor	$\gamma_{Ms}^{1)}$	1,33			
Characteristic resistance concrete pryout failure					
Factor in equation (5.6) of ETAG 001 Annex C, 5.2.3.3	k	2,0			
Partial safety factor	$\gamma_{Mcp}^{1)}$	1,5 ²⁾			
Characteristic resistance concrete edge failure					
Effective length of anchor under shear load	l_f [mm]	60		70	
Effective diameter of anchor	d_{nom} [mm]	12		15	
Partial safety factor	$\gamma_{Mc}^{1)}$	1,5 ²⁾			

¹⁾ In absence of other national regulations.

²⁾ The partial safety factor $\gamma_2 = 1,0$ is included.

fischer High-Performance Anchor FH II, FH II-I

Design method A
Characteristic values for shear loads FH II-I and FH II-I A4

Annex 10

Table 15: Displacements under shear loads FH II S and SK ¹⁾

Anchor type FH II S and FH II SK			FH II 10	FH II 12	FH II 15	FH II 18	FH II 24	FH II 28	FH II 32
Shear load in cracked and non-cracked concrete	V	[kN]	10,3	18,9	33,7	43,4	83,4	99,4	124,0
Corresponding displacements	δ_{v0}	[mm]	2,4	2,7	4,4	5,0	7,0	6,0	8,0
	$\delta_{v\infty}$	[mm]	3,6	4,1	6,6	7,5	10,5	9,0	12,0

¹⁾ Tolerance of clearance hole not included in the displacements.

Table 16: Displacements under shear loads FH II B and H ¹⁾

Anchor type: FH II B and FH II H			FH II 10	FH II 12	FH II 15	FH II 18	FH II 24	FH II 28	FH II 32
Shear load in cracked and non-cracked concrete	V	[kN]	8,9	15,4	23,4	35,4	68,0	83,4	96,6
Corresponding displacements	δ_{v0}	[mm]	2,2	2,3	3,0	5,0	7,0	5,0	5,0
	$\delta_{v\infty}$	[mm]	3,3	3,5	4,5	7,5	10,5	7,5	7,5

¹⁾ Tolerance of clearance hole not included in the displacements.

Table 17: Displacements under shear loads FH II S A4, FH II SK A4, FH II B A4 and FH II H A4 ¹⁾

Anchor type: FH II S A4, FH II SK A4, FH II B A4, FH II H A4			FH II 10	FH II 12	FH II 15	FH II 18	FH II 24
Shear load in cracked and non-cracked concrete	V	[kN]	10,3	16,0	24,6	37,7	68,0
Corresponding displacements	δ_{v0}	[mm]	3,5	3,5	3,7	5,7	9,0
	$\delta_{v\infty}$	[mm]	5,3	5,3	5,6	8,6	13,5

¹⁾ Tolerance of clearance hole not included in the displacements.

Table 18: Displacements under shear loads FH II-I and FH II-I A4¹⁾

Anchor type FH II-I and FH II-I A4			FH II 12/M6 I	FH II 12/M8 I	FH II 15/M10 I	FH II 15/M12 I
Shear load in cracked and non-cracked concrete	V	[kN]	4,6	8,3	13,3	13,7
Corresponding displacements	δ_{v0}	[mm]	2,6	2,6	2,2	2,2
	$\delta_{v\infty}$	[mm]	3,9	3,9	3,3	3,3

¹⁾ Tolerance of clearance hole not included in the displacements.

fischer High-Performance Anchor FH II, FH II-I

Design method A
Characteristic displacements for shear loads

Annex 11

Table 19: Characteristic tension resistance under fire exposure

Anchor type	R30			R60		
	$N_{Rk,s,fi,30}$ [kN]	$N_{Rk,p,fi,30}$ [kN]	$N_{Rk,c,fi,30}^0$ [kN]	$N_{Rk,s,fi,60}$ [kN]	$N_{Rk,p,fi,60}$ [kN]	$N_{Rk,c,fi,60}^0$ [kN]
FH II 10 (A4)	0,2	1,8	1,8	0,2	1,8	1,8
FH II 12 (A4)	2,0	3,0	5,0	1,3	3,0	5,0
FH II 15 (A4)	3,2	4,0	7,4	2,3	4,0	7,4
FH II 18 (A4)	4,8	6,3	10,3	3,9	6,3	10,3
FH II 24 (A4)	8,9	9,0	18,0	7,3	9,0	18,0
FH II 28	13,9	12,6	31,4	11,3	12,6	31,4
FH II 32	20,0	16,5	49,6	16,3	16,5	49,6
FH II 12/M6 I (A4) 5.8/A50 ¹⁾	0,1	2,3	5,0	0,1	2,3	5,0
with fastener 8.8, A70, A80 ¹⁾	0,2			0,2		
FH II 12/M8 I (A4) 5.8/A50 ¹⁾	1,3	3,0	7,4	0,8	3,0	7,4
with fastener 8.8, A70, A80 ¹⁾	2,0			1,3		
FH II 15/M10 I (A4) 5.8/A50 ¹⁾	2,0	3,0	7,4	1,4	3,0	7,4
with fastener 8.8, A70, A80 ¹⁾	3,2			2,3		
FH II 15/M12 I (A4) 5.8/A50 ¹⁾	3,0			2,4		
with fastener 8.8, A70, A80 ¹⁾	4,8			3,9		
	R90			R120		
	$N_{Rk,s,fi,90}$ [kN]	$N_{Rk,p,fi,90}$ [kN]	$N_{Rk,c,fi,90}^0$ [kN]	$N_{Rk,s,fi,120}$ [kN]	$N_{Rk,p,fi,120}$ [kN]	$N_{Rk,c,fi,120}^0$ [kN]
FH II 10 (A4)	0,1	1,8	1,8	0,1	1,5	1,5
FH II 12 (A4)	0,6	3,0	5,0	0,2	2,4	4,0
FH II 15 (A4)	1,4	4,0	7,4	1,0	3,2	5,9
FH II 18 (A4)	3,0	6,3	10,3	2,6	5,0	8,2
FH II 24 (A4)	5,6	9,0	18,0	4,8	7,2	14,4
FH II 28	8,8	12,6	31,4	7,5	10,1	25,2
FH II 32	12,6	16,5	49,6	10,8	13,2	39,7
FH II 12/M6 I (A4) 5.8/A50 ¹⁾	0,1	2,3	5,0	0,1	1,8	4,0
with fastener 8.8, A70, A80 ¹⁾	0,1			0,1		
FH II 12/M8 I (A4) 5.8/A50 ¹⁾	0,4	3,0	7,4	0,1	2,4	5,9
with fastener 8.8, A70, A80 ¹⁾	0,6			0,2		
FH II 15/M10 I (A4) 5.8/A50 ¹⁾	0,9			0,6		
with fastener 8.8, A70, A80 ¹⁾	1,4			1,0		
FH II 15/M12 I (A4) 5.8/A50 ¹⁾	1,9	3,0	7,4	1,6	2,4	5,9
with fastener 8.8, A70, A80 ¹⁾	3,0			2,6		

Anchor type		FH II 10	FH II 12 FH II 12-I	FH II 15 FH II 15-I	FH II 18	FH II 24	FH II 28	FH II 32
Spacing	$S_{cr,N}$ [mm]	4x h _{ef}						
	S_{min} [mm]	40	60	70	80	100	125	150
Edge distance	$C_{cr,n}$ [mm]	2 x h _{ef}						
	C_{min} [mm]	C _{min} = 2 x h _{ef} , for fire exposure from more than one side C _{min} > 300 mm						

¹⁾ Intermediate values by linear interpolation

In absence of other national regulations the partial safety factor for resistance under fire exposure $\gamma_{M,fi} = 1,0$ is recommended.

fischer High-Performance Anchor FH II, FH II-I

Characteristic tension load resistance
under fire exposure according to TR 020

Annex 12

Table 20: Characteristic shear resistance under fire exposure, steel failure

Anchor type	R30		R60	
	Fire resistance 30 minutes		Fire resistance 60 minutes	
	$V_{Rk,s,fi,30}$ [kN]	$M_{Rk,s,fi,30}^0$ [Nm]	$V_{Rk,s,fi,60}$ [kN]	$M_{Rk,s,fi,60}^0$ [Nm]
FH II 10 (A4)	0,3	0	0,3	0
FH II 12 (A4)	2,0	2	1,3	1
FH II 15 (A4)	3,2	4	2,3	3
FH II 18 (A4)	4,8	7	3,9	6
FH II 24 (A4)	8,9	19	7,3	15
FH II 28	13,9	37	11,3	30
FH II 32	20,0	64	16,3	52
FH II 12/M6 I (A4) 5.8/A50	0,2	0	0,2	0
with fastener 8.8, A70, A80	0,3	0	0,3	0
FH II 12/M8 I (A4) 5.8/A50	1,3	1	0,8	1
with fastener 8.8, A70, A80	2,0	2	1,3	1
FH II 15/M10 I (A4) 5.8/A50	2,0	3	1,4	2
with fastener 8.8, A70, A80	3,2	4	2,3	3
FH II 15/M12 I (A4) 5.8/A50	3,0	4	2,4	4
with fastener 8.8, A70, A80	4,8	7	3,9	6
	R90		R120	
	Fire resistance 90 minutes		Fire resistance 120 minutes	
	$V_{Rk,s,fi,90}$ [kN]	$M_{Rk,s,fi,90}^0$ [Nm]	$V_{Rk,s,fi,120}$ [kN]	$M_{Rk,s,fi,120}^0$ [Nm]
FH II 10 (A4)	0,2	0	0,1	0
FH II 12 (A4)	0,6	1	0,2	0
FH II 15 (A4)	1,4	2	1,0	1
FH II 18 (A4)	3,0	5	2,6	4
FH II 24 (A4)	5,6	12	4,8	10
FH II 28	8,8	23	7,5	20
FH II 32	12,6	40	10,8	34
FH II 12/M6 I (A4) 5.8/A50	0,1	0	0,1	0
with fastener 8.8, A70, A80	0,2	0	0,1	0
FH II 12/M8 I (A4) 5.8/A50	0,4	1	0,1	0
with fastener 8.8, A70, A80	0,6	1	0,2	0
FH II 15/M10 I (A4) 5.8/A50	0,9	2	0,6	1
with fastener 8.8, A70, A80	1,4	3	1,0	1
FH II 15/M12 I (A4) 5.8/A50	1,9	4	1,6	3
with fastener 8.8, A70, A80	3,0	6	2,6	4

Concrete pryout failure: In Equation (5.6) of ETAG 001, Annex C, 5.2.3.3, the k-factor for FH II 12-32 is 2,0, respectively 1,0 for FH II 10 and the relevant values of $N_{Rk,c,fi}$ of Table 19 have to be considered in the design.

Concrete edge failure: The characteristic resistance $V_{0Rk,c,fi}$ in concrete C20/25 to C50/60 is determined by: $V_{0Rk,c,fi} = 0,25 \times V_{0Rk,c}$ (R30, R60, R90)

$V_{0Rk,c,fi} = 0,20 \times V_{0Rk,c}$ (R120) with $V_{0Rk,c}$ as initial value of the characteristic resistance in cracked concrete C20/25 under normal temperature according to ETAG 001, Annex C, 5.2.3.4.

In absence of other national regulations the partial safety factor for resistance under fire exposure $\gamma_{M,fi} = 1,0$ is recommended.

fischer High-Performance Anchor FH II, FH II-I

Characteristic shear load resistance
under fire exposure according to TR 020

Annex 13

Installation instruction for the fischer high performance anchor FH II 10 - FH II 32 and FH II 10 A4 - FH II 24 A4

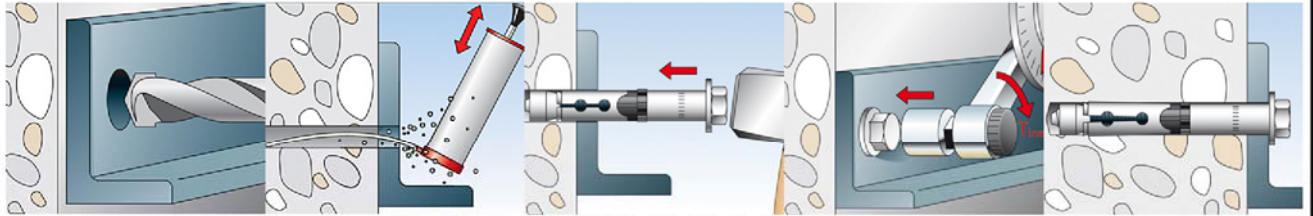

Installation instruction FH II 10 - 32 S and FH II 10-24 S A4

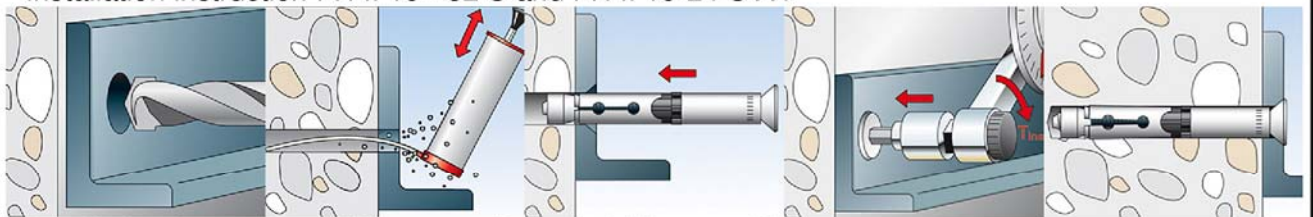

Installation instruction FH II 10 - 18 SK and FH II 10-18 SK A4

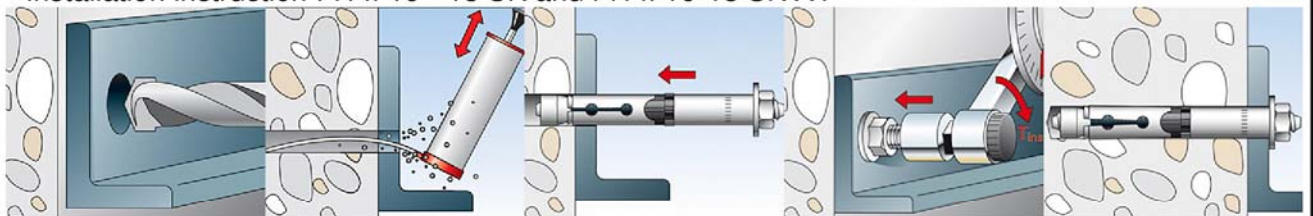

Installation instruction FH II 10 - 32 B and FH II 10-24 B A4

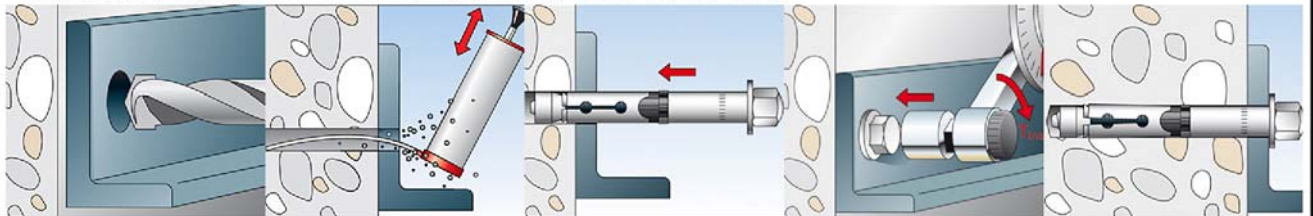

Installation instruction FH II 10 - 24 H and FH II 10-24 H A4

fischer High-Performance Anchor FH II, FH II-I

Installation instruction FH II and FH II A4

Annex 14

Installation instruction for the fischer high performance anchor internal thread FH II-I and FH II-I A4

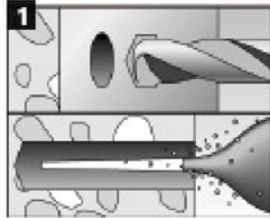

Check if the cone nut is in contact with the sleeve. If not, tighten the anchor so that the cone nut is close to the expansion sleeve.

1.) Drilling and cleaning the hole.

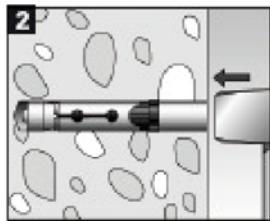

2.) Hammering in the anchor flushed with the surface of the concrete.

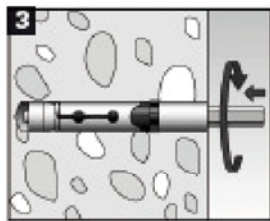

3.) Tightening the anchor. Tightening with the included hexagon in the package is preferred. Other tightening methods are allowed.

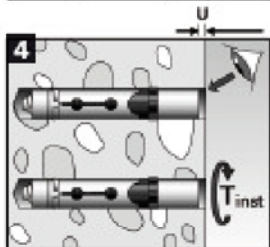

4.) Tighten the anchor into the concrete until the gap U is 3-5 mm or the installation torque is reached. Only one requirement has to be fulfilled.

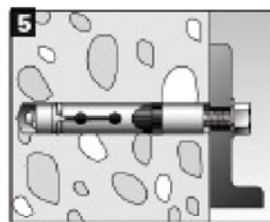

5.) Connecting the fixing and the anchor with a fitting fastener. The length of the fastener should be determined depending on the thickness of fixture t_{fix} , admissible tolerances, and available thread length $l_{s,max}$ and $l_{s,min}$ including the gap U .

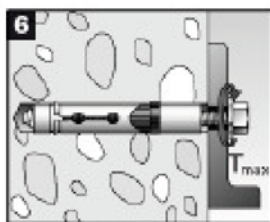

6.) Tightening the anchor with the torque $\leq T_{max}$.

fischer High-Performance Anchor FH II, FH II-I

Installation instruction FH II-I and FH II-I A4

Annex 15