

European Technical Approval ETA-11/0267

English translation prepared by DIBt - Original version in German language

Handelsbezeichnung
Trade name

Feuerschutzabschluss "ECClos-S" im Zuge von bahngelassenen
Förderanlagen
Kit for closure systems "ECClos-S" for conveyor systems

Zulassungsinhaber
Holder of approval

Stöbich Brandschutz GmbH
Pracherstieg 6
38644 Goslar
DEUTSCHLAND

Zulassungsgegenstand
und Verwendungszweck
*Generic type and use
of construction product*

Feuerschutzabschluss "ECClos-S" im Zuge von bahngelassenen
Förderanlagen
Kit for closure systems "ECClos-S" for conveyor systems

Geltungsdauer:
Validity: vom
from
bis
to

11 October 2012
16 September 2016

Herstellwerk
Manufacturing plant

Stöbich Brandschutz GmbH
Pracherstieg 6
38644 Goslar
DEUTSCHLAND

Diese Zulassung umfasst
This Approval contains

28 Seiten einschließlich 17 Anhänge
28 pages including 17 annexes

Diese Zulassung ersetzt
This Approval replaces

ETA-11/0267 mit Geltungsdauer vom 16.09.2011 bis 16.09.2016
ETA-11/0267 with validity from 16.09.2011 to 16.09.2016

I LEGAL BASES AND GENERAL CONDITIONS

- 1 This European technical approval is issued by Deutsches Institut für Bautechnik in accordance with:
 - Council Directive 89/106/EEC of 21 December 1988 on the approximation of laws, regulations and administrative provisions of Member States relating to construction products¹, modified by Council Directive 93/68/EEC² and Regulation (EC) N° 1882/2003 of the European Parliament and of the Council³;
 - *Gesetz über das In-Verkehr-Bringen von und den freien Warenverkehr mit Bauprodukten zur Umsetzung der Richtlinie 89/106/EWG des Rates vom 21. Dezember 1988 zur Angleichung der Rechts- und Verwaltungsvorschriften der Mitgliedstaaten über Bauprodukte und anderer Rechtsakte der Europäischen Gemeinschaften (Bauproduktengesetz - BauPG) vom 28. April 1998⁴, as amended by Article 2 of the law of 8 November 2011⁵;*
 - Common Procedural Rules for Requesting, Preparing and the Granting of European technical approvals set out in the Annex to Commission Decision 94/23/EC⁶.
- 2 Deutsches Institut für Bautechnik is authorized to check whether the provisions of this European technical approval are met. Checking may take place in the manufacturing plant. Nevertheless, the responsibility for the conformity of the products to the European technical approval and for their fitness for the intended use remains with the holder of the European technical approval.
- 3 This European technical approval is not to be transferred to manufacturers or agents of manufacturers other than those indicated on page 1, or manufacturing plants other than those indicated on page 1 of this European technical approval.
- 4 This European technical approval may be withdrawn by Deutsches Institut für Bautechnik, in particular pursuant to information by the Commission according to Article 5(1) of Council Directive 89/106/EEC.
- 5 Reproduction of this European technical approval including transmission by electronic means shall be in full. However, partial reproduction can be made with the written consent of Deutsches Institut für Bautechnik. In this case partial reproduction has to be designated as such. Texts and drawings of advertising brochures shall not contradict or misuse the European technical approval.
- 6 The European technical approval is issued by the approval body in its official language. This version corresponds fully to the version circulated within EOTA. Translations into other languages have to be designated as such.

¹ Official Journal of the European Communities L 40, 11 February 1989, p. 12

² Official Journal of the European Communities L 220, 30 August 1993, p. 1

³ Official Journal of the European Union L 284, 31 October 2003, p. 25

⁴ *Bundesgesetzblatt Teil I 1998*, p. 812

⁵ *Bundesgesetzblatt Teil I 2011*, p. 2178

⁶ Official Journal of the European Communities L 17, 20 January 1994, p. 34

II SPECIFIC CONDITIONS OF THE EUROPEAN TECHNICAL APPROVAL

1 Definition of the product and intended use

1.1 Definition of the construction product

This European technical approval applies for the closure system "ECClos-S" for conveyor systems, hereinafter referred to as "ECClos-S". The closure system can be designed to close vertically from the top down or horizontally. "ECClos-S" primarily consists of the following components⁷:

- Single-leaf sliding leaf

The approx. 122 mm thick sliding leaf can consist of one part or multiple parts (segment construction). The sliding leaf or one sliding leaf segment consists of two layers of mineral fibre board bonded with synthetic resin (each 50 mm thick) between which a gypsum board (20 mm thick) is secured with water glass adhesive. 0.75 mm thick steel sheet formwork is glued to the outside of the mineral fibre boards. Calcium silicate boards (2 x 20 mm) covered by a frame profile are fastened to the edges of the sliding leaf.

- Fixed panel with clearance for the conveyor

The fixed panel consists of aerated concrete stones 150 mm thick to which thin bed mortar is applied, with an upper cover layer of 20 mm thick calcium silicate boards to the safety edge, and is secured to the wall via brackets (or floor-standing if used on flexible wall construction). The clearance in the fixed panel is configured for the respective conveyor technology. Various intumescent materials are used in the necessary functional gaps.

- Guide for the sliding leaf

- Vertical closing (from top to bottom)

Guide braces secured at the side of the sliding leaf grip a wall frame (2 mm) secured to the wall. Grip plates secured at the top of the sliding leaf grip behind locking nuts, which in turn are secured to the wall using fasteners such as threaded bolts or anchors, when closing.

- Horizontal closing

Depending on the weight, three different methods of suspending the sliding leaf are possible:

- a) up to 200 kg: two single sets of running gear with polyamide rollers on an oval pipe rail
- b) up to 400 kg: single set of running gear with steel rollers on a flat steel rail
- c) up to 780 kg: double set of running gear with steel rollers on a flat steel rail

The sliding leaf is guided by a guide roller which runs in a guide profile of the sliding leaf. The rail is secured to the wall using brackets. Grip plates secured on the opening side of the sliding leaf grip behind locking nuts, which in turn are secured to the wall using fasteners such as threaded bolts or anchors, when closing.

⁷ The documents describing the structure of "ECClos-S" in detail and the product specifications of the building materials used are deposited with DIBt.

- Seal system
Strips of an intumescent material are positioned as follows in the closure area:
 - on the wall, on bases of 20-mm-thick calcium silicate boards in the overlap of the sliding leaf and adjacent wall
 - on the side of the sliding leaf facing the wall
 - on the lower edge of the sliding leaf
 - in the conveyor technology area in the fixed panel
 - On the face of the sealing frame
- Closing device (closing weight system)
In versions with horizontal closing, the closure is closed via a closing weight system or spring force, and in versions with vertical closing, the deadweight of the sliding leaf is used for closing.

1.2 Intended use

The "ECClos-S" can be used as a normally-open closure (open in the normal position; closes in the event of a fire; see section 2.1.2) to seal necessary openings in internal walls. When used, in particular the permitted service conditions of the intumescent materials used are to be observed.

The "ECClos-S" shall only be used if the following conditions apply:

- The normally-open closure shall be equipped with a hold-open system suitable for the closure – where applicable in conjunction with the national regulations.
- The normally-open closure, which cannot be opened from a fixed position (floor, pedestal etc.), is to be equipped with a drive to open the closure.
- It is to be ensured that the closing of the closure is not obstructed by conveyed goods or other objects.
- It is to be ensured that the closed closure cannot be damaged by conveyed goods or other objects.

In accordance with this European technical approval, the "ECClos-S" can be used to seal wall openings of trackbound conveyors (chain, roller and belt conveyors) in accordance with table 1.

Table 1: Permitted dimensions of the clearance of the component opening

Component (supporting construction) in which the closure can be installed ^{a)}	Maximum fire resistance class ^{b)}	Clearance of the component opening ^{c)}		
		Maximum width (clear width)	Maximum height (clear height)	Maximum surface (direction of closing)
High-density solid wall Masonry or solid concrete with an overall density of $\geq 800 \text{ kg/m}^3$ and a thickness $\geq 200 \text{ mm}$	E 120	4,500 mm	5,100 mm	13.5 m ²
	EI ₁ 90			(horizontal)
	EI ₂ 120			12.1 m ²
	EW 60			(vertical)
Low-density solid wall Aerated concrete with an overall density of $\geq 450 \text{ kg/m}^3$ and a thickness $\geq 200 \text{ mm}$	E 120	4,500 mm	4,770 mm	13.5 m ²
	EI ₁ 90			(horizontal)
	EI ₂ 120			12.1 m ²
	EW 60			(vertical)
Flexible wall construction (gypsum board type F to EN 520) Thickness $\geq 160 \text{ mm}$	E 120	4,500 mm	4,500 mm	13.5 m ²
	EI ₁ 90			(horizontal)
	EI ₂ 120			12.1 m ²
	EW 60			(vertical)
	EI ₁ 120	3,000 mm	3,400 mm	10.0 m ²
a) Supporting construction to EN 1366-7 ⁸ , section 7.2 or EN 1363-1 ⁹ , section 7.2				
b) Fire resistance class per EN 13501-2 ¹⁰ in accordance with the Evaluation Report				
c) Minimum dimension unrestricted				

In order to seal the continuous conveyor technology, the sealing systems specified in table 2 can be used.

⁸ EN 1366-7:2004 Fire resistance tests for service installations - Part 7: Conveyor systems and their closures

⁹ EN 1363-1:1999 Fire resistance tests - Part 1: General requirements

¹⁰ EN 13501-2:2007 Fire classification of construction products and building elements - Part 2: Classification using data from fire resistance tests, excluding ventilation services

Table 2: Permitted sealing systems for the continuous conveyor technology¹¹

Sealing system for	Fixed panel thickness (and material)	Minimum penetration seal depth of the seal on the fixed panel (Penetration seal via calcium silicate boards)	Minimum penetration seal depth at the sliding leaf (and poss. material)	Maximum fire resistance class
Roll conveyor	150 mm (aerated concrete)	Continuous steel profiles: 175 mm Continuous aluminium profiles: 250 mm Between the rollers: 2 x 25 mm webs or 4 x 15 mm webs	Sliding leaf thickness	EI 120
Belt conveyor	150 mm (aerated concrete)	Continuous steel profiles: 175 mm Continuous aluminium profiles: 250 mm	Sliding leaf thickness	EI 120
Chain conveyor	150 mm (aerated concrete)	Continuous steel profiles: 175 mm Continuous aluminium profiles: 250 mm	Sliding leaf thickness	EI 120

The conveyor tracks shall be positioned at the bottom and can be continuous in the closing area of the sliding leaf.

The conditions of this European technical approval are based on an assumed working life of the "ECClos-S" of 10 years, provided the conditions for packaging, transport, storage, installation, use, maintenance and repair specified in sections 4.2, 5.1/5.2 are fulfilled.

The indications given on the working life cannot be interpreted as a guarantee given by the manufacturer, but are to be regarded only as a means for choosing the right products in relation to the expected economically reasonable working life of the works.

2 Characteristics of the product and method of verification

2.1 Characteristics of the assembled system and method of verification

2.1.1 Fire resistance

The fire resistance was determined in accordance with EN 1366-7⁸. The fire resistance classes specified in section 1.2 were verified in accordance with EN 13501-2¹⁰.

¹¹ see Annexes 13 to 15

2.1.2 Durability

The durability was determined in accordance with EN 14600¹². The horizontally closing closure systems were tested through 200,000 cycles and the vertically closing closure systems were tested through 174,800 cycles. For horizontally closing closure systems, class C5 was demonstrated, and class C4 was demonstrated for vertically closing closure systems.

The drive belts or steel cables and deflection rollers, as well as the roller devices and the rail for the horizontal closing version shall be selected in accordance with the load bearing capacity specifications of the manufacturer for the weight of the sliding leaf.

2.1.3 Release of dangerous substances

According to the manufacturer's statements, the components of the "ECClos-S" were compared with the dangerous substances specified in Council Directive 76/769/EEC (amended version) and in the database on the construction industry website of the European Commission, and it was found that the permitted limits for these dangerous substances are not exceeded.

Note: In addition to the specific clauses relating to dangerous substances contained in this European technical approval, there may be other requirements applicable to the products falling within its scope (e.g. transposed European legislation and national laws, regulations and administrative provisions). In order to meet the provisions of the Construction Products Directive, these requirements shall also be complied with, when and where they apply.

2.1.4 Closing speed

The closing speed on the closing device shall be set such that compliance with the requirements per EN 14600¹² is ensured.

2.1.5 Closing and opening force

The applicant for this European technical approval shall specify the closing and opening force of the closure. The personal health and safety requirements per EN 12453¹³ were not verified.

2.2 Characteristics of the components of the system and method of verification

2.2.1 Moving sliding leaf and fixed panel with clearance for the conveyor

Reaction to fire⁷

The components of the galvanised steel sheet sliding leaf were classified for their reaction to fire in accordance with Decision 96/603/EC and 2000/605/EC of the European Commission¹⁴ as Class A1 per EN 13501-1¹⁵.

The following construction materials were classified as Class A1 per EN 13501-1¹⁵ for their reaction to fire:

- Calcium silicate boards
- Gypsum boards
- Aerated concrete stones and thin bed mortar

The following materials fulfil at least the requirements for reactions to fire of Class E materials per EN 13501-1¹⁵:

12	EN 14600:2005	Doorsets and openable windows with fire resisting and/or smoke control characteristics - Requirements and classification
13	EN 12453:2000	Industrial, commercial and garage doors and gates - Safety in use of power operated doors - Requirements
14	Official Journal of the European Communities L 267/23 of 19/10/1996 and L258/36 of 12/10/2000	
15	EN 13501-1:2007	Fire classification of construction products and building elements - Part 1: Classification using data from reaction to fire tests

- Mineral fibre boards bonded with synthetic resin
- Water glass adhesive
- PU adhesive

2.2.2 Guide for the sliding leaf

Reaction to fire⁷

Per Decision 96/603/EC of the European Commission¹⁴, galvanised steel profiles satisfy the requirements in accordance with fire resistance class A1 per EN 13501-1¹⁵.

The calcium silicate boards were classified as Class A1 per EN 13501-1¹⁵ for their reaction to fire.

2.2.3 Sealing system consisting of intumescent materials

2.2.3.1 Reaction to fire⁷

The intumescent materials

- Tenmat Firefly 102,
- Promaseal PL, and
- Palusol 100,

which are used for the sealing system, fulfil at least the requirements for reactions to fire of Class E materials per EN 13501-1¹⁵.

2.2.3.2 Expansion ratio and expansion pressure of intumescent materials after aging

The characteristics and the fire performance criteria of the intumescent materials used were determined after loading and are deposited with DIBt.

2.2.3.3 Identification

The intumescent materials used as a sealing system can be identified via their thickness, density and their expansion ratio as well as via their ash content and expansion pressure in accordance with the methods specified in section 5.2 of CUAP 11.07/02. A fingerprint and the chemical composition are deposited with DIBt for the intumescent materials.

2.2.4 Closing device (closing weight system)

2.2.4.1 Reaction to fire

The closing weights are made of cast iron, the cables, roller devices and deflection rollers are made of steel and the flashings are made of steel sheet.

- Per Decision 96/603/EC of the European Commission¹⁴, cast iron and steel sheet satisfy the requirements in accordance with fire resistance class A1 per EN 13501-1¹⁵.

2.2.4.2 Temperature dependence

The change in the closing time at ambient temperatures from 0 °C to 40 °C shall be less than 25 % compared with the closing time at room temperature (20 °C).

2.2.4.3 Corrosion reaction

No defined corrosion resistance (corresponds to Class 0) was verified for the closing device per EN 1670¹⁶.

¹⁶

EN 1670:2007

Building hardware - Corrosion resistance - Requirements and test methods

3 Evaluation and attestation of conformity and CE marking

3.1 System of conformity attestation

Per Decision 1999/454/EC of the European Commission¹⁷ and the amendment per Decision 2001/596/EC of the European Commission¹⁸, conformity attestation system 1 is applicable.

This system of conformity attestation is defined as follows:

System 1: Certification of the conformity of the product by an approved certification body on the basis of:

(a) Tasks for the manufacturer:

- (1) Factory production control
- (2) Further testing of samples taken at the factory by the manufacturer in accordance with a prescribed test plan

(b) Tasks for the approved body:

- (3) Initial type testing of the product
- (4) Initial inspection of the factory and of factory production control
- (5) Continuous monitoring, assessment and approval of factory production control

Note: Approved bodies are also referred to as "notified bodies".

3.2 Responsibilities

3.2.1 Tasks for the manufacturer

3.2.1.1 Factory production control

The manufacturer shall exercise permanent internal control of production. All the elements, requirements and provisions adopted by the manufacturer shall be documented in a systematic manner in the form of written policies and procedures, including records of results performed. This production control system shall ensure that the product is in conformity with this European technical approval.

The manufacturer is only to use components stated in the technical documentation of this European technical approval.

The factory production control shall be in accordance with the "Control plan of 16 September 2011 relating to the European technical approval ETA-11/0267 issued on 11. October 2012" which is part of the technical documentation of this European technical approval. The control plan is laid down in the context of the factory production control system operated by the manufacturer and deposited with Deutsches Institut für Bautechnik.¹⁹

The results of factory production control shall be recorded and evaluated in accordance with the provisions of the control plan.

3.2.1.2 Other tasks for the manufacturer

The manufacturer shall provide installation instructions which contain at least the following information:

- Information for the installation of the closure system (e. g., adjacent components, permitted fasteners, fastening distances, joint design)

¹⁷ Official Journal of the European Communities L 178/52 of 14/7/1999

¹⁸ Official Journal of the European Communities L 209/33 of 2/8/2001

¹⁹ The control plan is a confidential part of the European technical approval and only handed over to the approved body involved in the procedure of attestation of conformity. See section 3.2.2.

- Notes on the sequence of steps for installation
- Information on the permitted accessory parts for the closure system
- Information on functional interplay of all parts
- Information on the use of hold-open systems
- Information on the interplay of the closure system, conveyor, hold-open system and emergency power supply

The manufacturer shall, on the basis of a contract, involve a body which is approved for the tasks referred to in section 3.1 in the field of closure systems for trackbound conveyors in order to undertake the actions laid down in section 3.2.2. For this purpose, the manufacturer shall submit the control plan in accordance with sections 3.2.1.1 and 3.2.2 to the approved body.

3.2.2 Tasks for the approved bodies

The approved body shall perform the following tasks in accordance with the provisions of the control plan:

- Initial type-testing of the product
- Initial inspection of factory and of factory production control
- Continuous monitoring, assessment and approval of the factory production control

The approved body shall record the essential points of its actions referred to above and state the results obtained and conclusions drawn in a written report.

The approved certification body involved by the manufacturer shall issue an EC certificate of conformity of the product stating the conformity with the provisions of this European technical approval.

In cases where the provisions of the European technical approval and its control plan are no longer fulfilled, the certification body shall withdraw the certificate of conformity and inform Deutsches Institut für Bautechnik without delay.

3.3 CE marking

The CE marking is to be attached to the closure itself (steel sheet plate) and printed on the accompanying commercial documents. The letters "CE" shall be followed by the identification number of the approved certification body and be accompanied by the following additional information:

- Trade name: ECClos-S
- Name and address of the manufacturer (legal entity responsible for the manufacture)
- Last two digits of the year in which the CE marking was affixed
- Number of the EC certificate of conformity for the product
- ETA number
- Use category (fire resistance and durability classification)
- Closing force

4 Assumptions under which the fitness of the product for the intended use was assessed positively

4.1 Manufacturing

Steel parts no longer accessible after assembly shall be provided with lifetime corrosion protection. Steel parts accessible after assembly shall be provided with basic protection which is effective for at least three months after the delivery date.

Additional corrosion protection and basic protection (coatings) of the sheets are not required if galvanised fine sheets of at least zinc coating class Z 275 N A per EN 10 346²⁰ are used.

The European technical approval is issued for the product on the basis of agreed data/information, deposited with Deutsches Institut für Bautechnik, which identifies the product that has been assessed and judged. Changes to the product or production process, which could result in this deposited data/information being incorrect, should be notified to Deutsches Institut für Bautechnik before the changes are introduced. Deutsches Institut für Bautechnik will decide whether or not such changes affect the approval and consequently the validity of the CE marking on the basis of the approval and if so whether further assessment or alterations to the approval shall be necessary.

4.2 Installation

The closure system shall be connected to the adjacent components in such a way that the forces which occur when the closure system closes automatically and the forces resulting from deformations during fires can be absorbed by the fasteners in the long term. These forces shall not endanger the stability of the adjacent structure.

The connections with the adjacent components shown in appendices 16 and 17 fulfil this requirement without further verification.

For closure systems which close horizontally, and installation in an aerated concrete wall, the rail is to be secured to a reinforced concrete lintel along its entire length (including the parking area) in accordance with the static verification.

Note: Other requirements for the installation and function of the "ECClos-S" and the requirement for acceptance testing can result in accordance with the national regulations.

5 Indications to the manufacturer

5.1 Packaging, transport and storage

When storing the intumescent material, the conditions in the assessment criteria (ambient air with temperatures between 0 °C and 40 °C and 50 to 80% relative humidity) shall be observed.

5.2 Use, maintenance, repair

Maintenance instructions

The manufacturer shall provide maintenance instructions for every "ECClos-S". The maintenance instructions shall clearly indicate which work is to be performed to ensure that the installed closure system continues to perform its task after long-term use.

Inspection and maintenance

The "ECClos-S" shall be inspected for serviceability at least once a month. At least once a year, the system shall be maintained by qualified personnel authorised by the manufacturer. The results shall be noted in the test and maintenance log.

Note: Further maintenance requirements may result for the "ECClos-S" in conjunction with national regulations.

Prof. Gunter Hoppe
Head of department

beglaubigt:
Biedermann

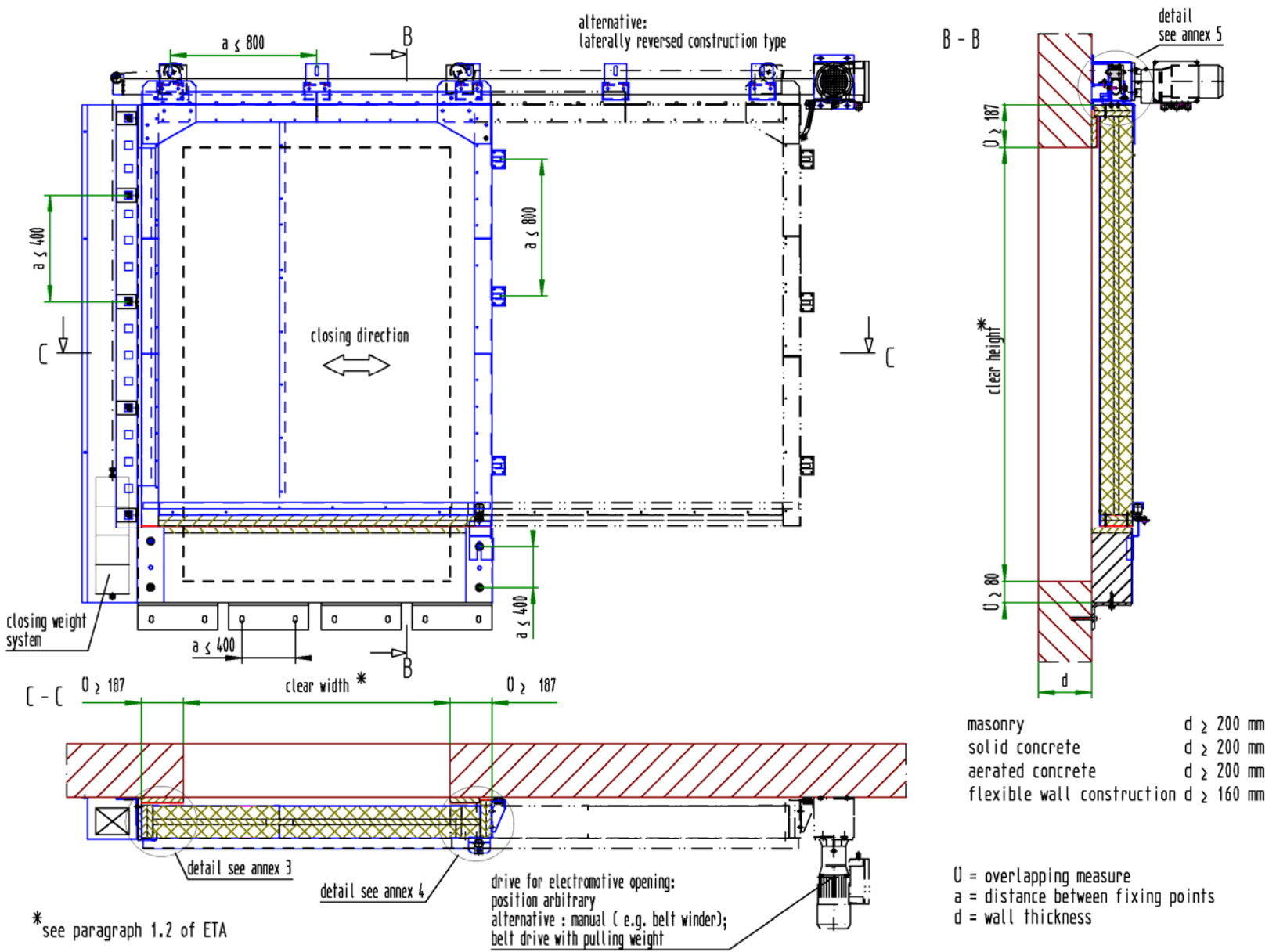

Kit for closure systems "ECCLos-S" for conveyor systems

Overview
Horizontal closing direction
(dimensions in mm)

Annex 1

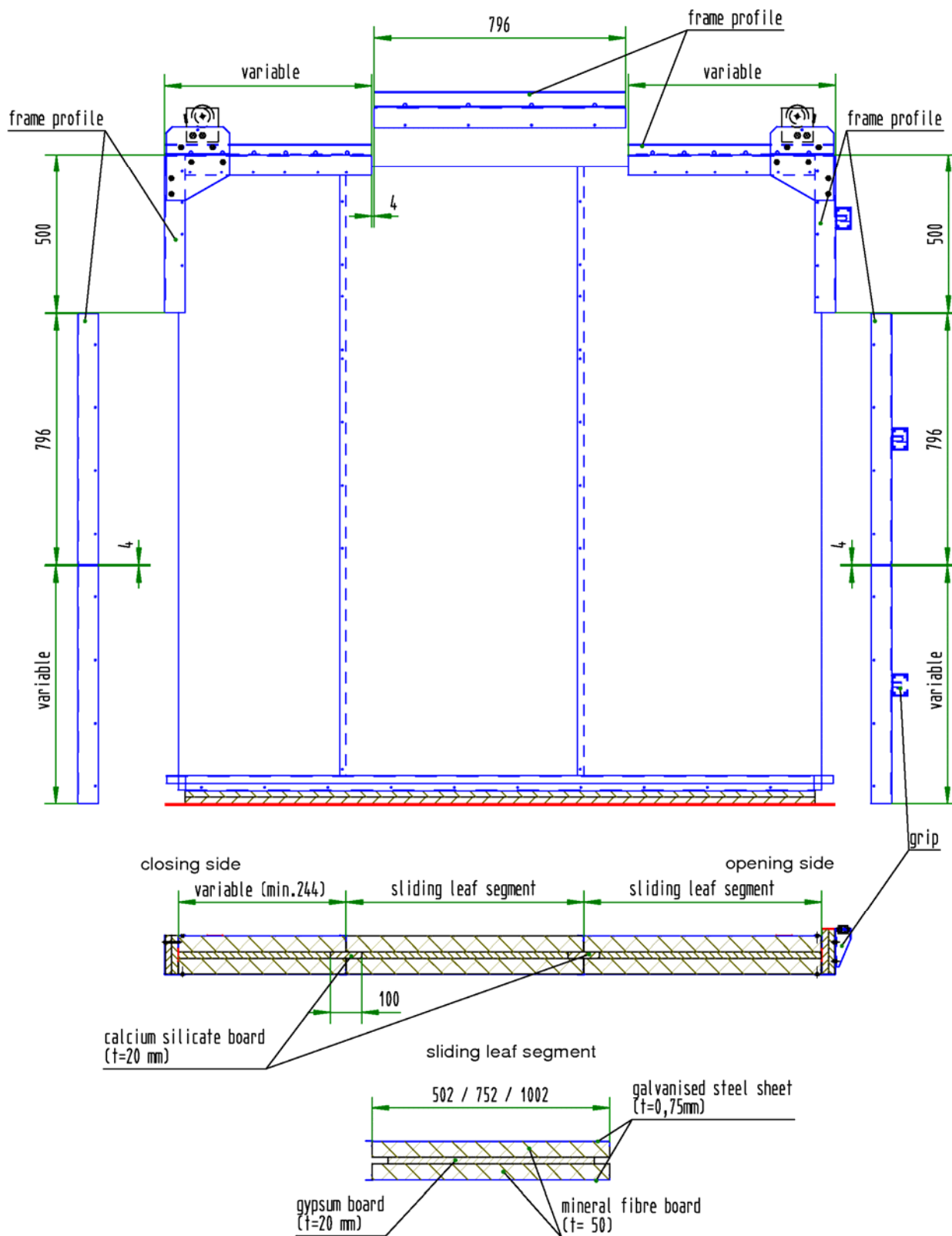

Kit for closure systems "ECClos-S" for conveyor systems

Sliding leaf construction
Horizontal closing direction
(dimensions in mm)

Annex 2

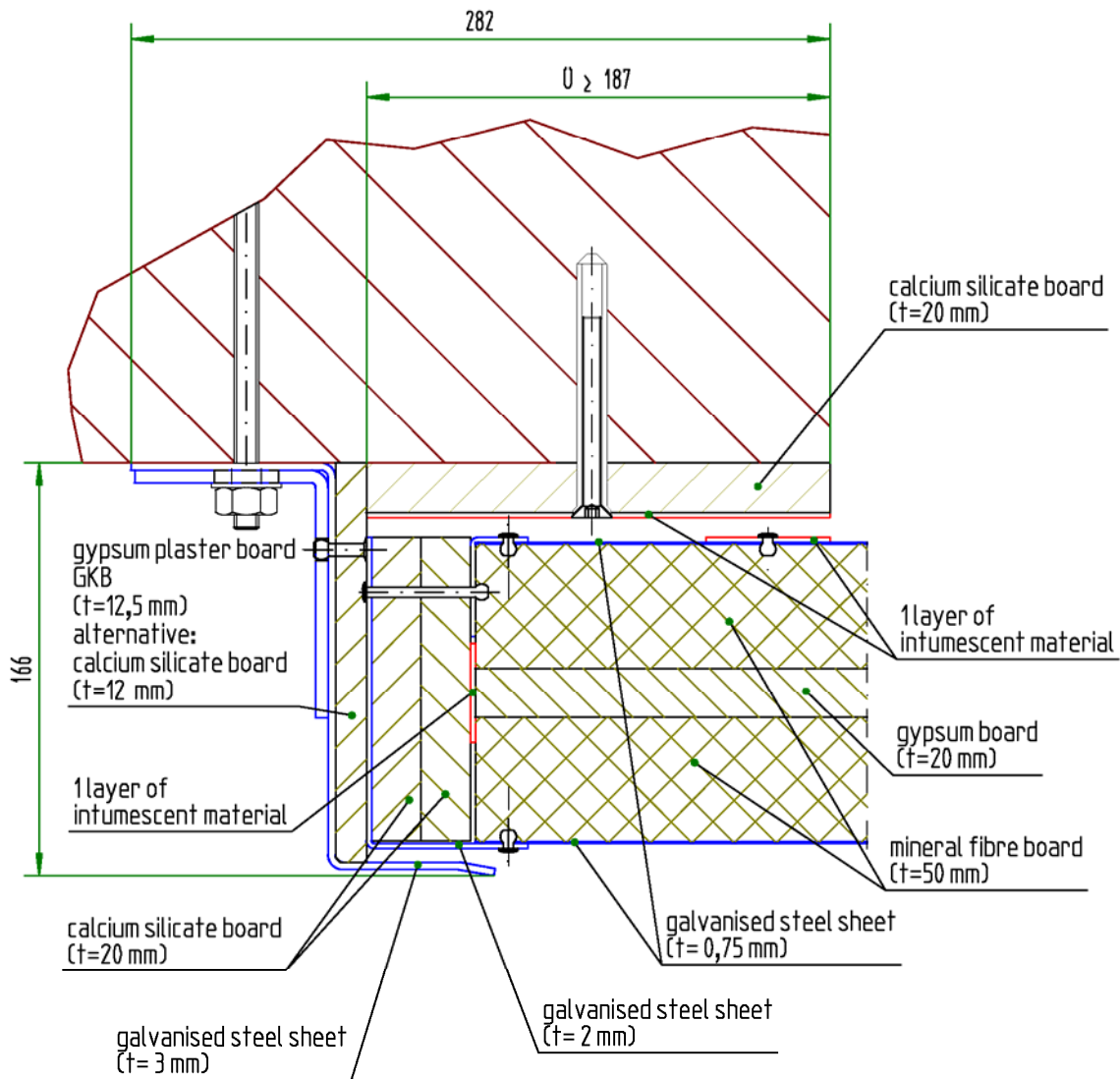

U = overlapping measure

Kit for closure systems "ECClos-S" for conveyor systems

Detail closing side
Horizontal closing direction
(dimensions in mm)

Annex 3

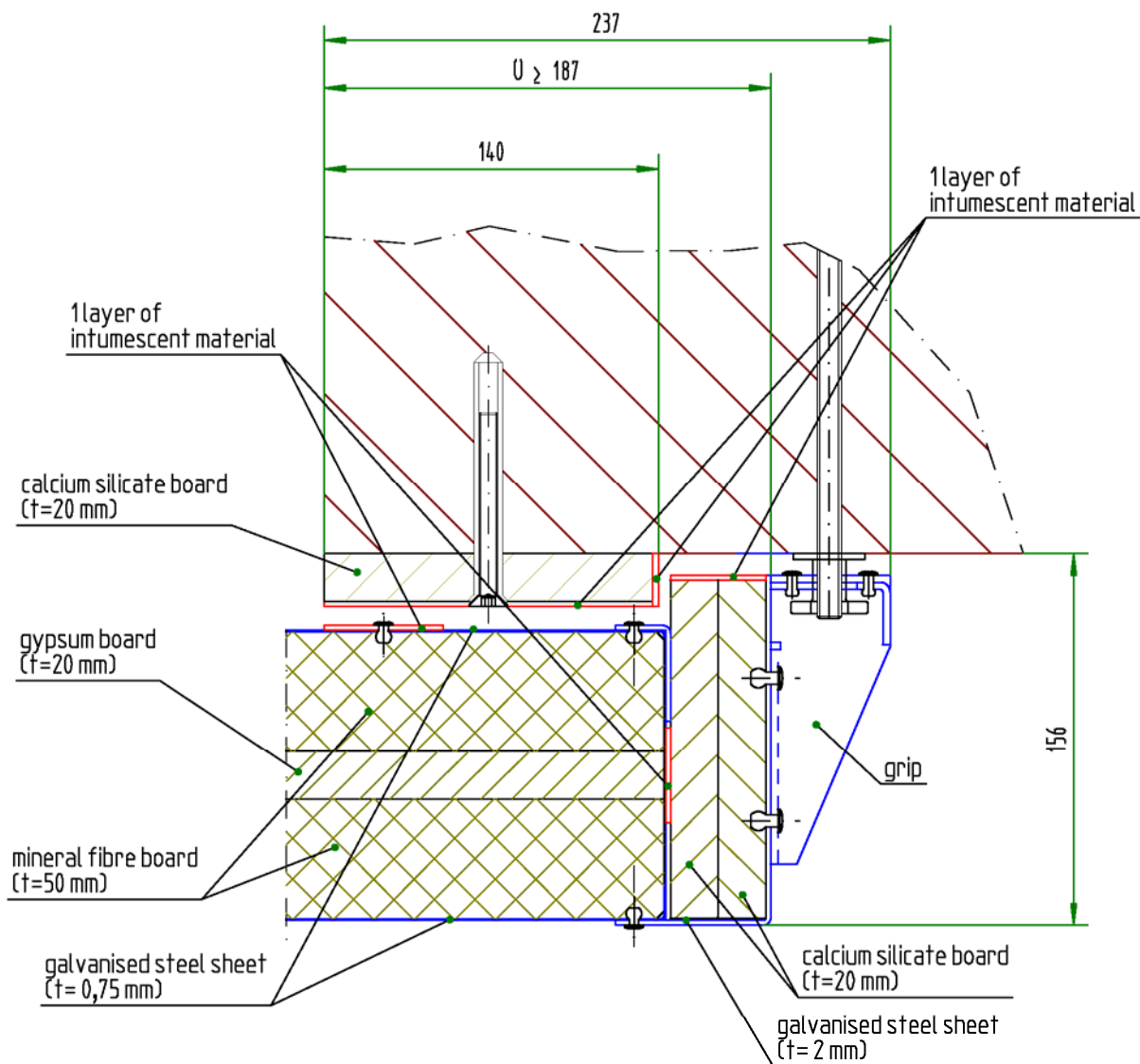

U = overlapping measure

Kit for closure systems "ECClos-S" for conveyor systems

Detail opening side
Horizontal closing direction
(dimensions in mm)

Annex 4

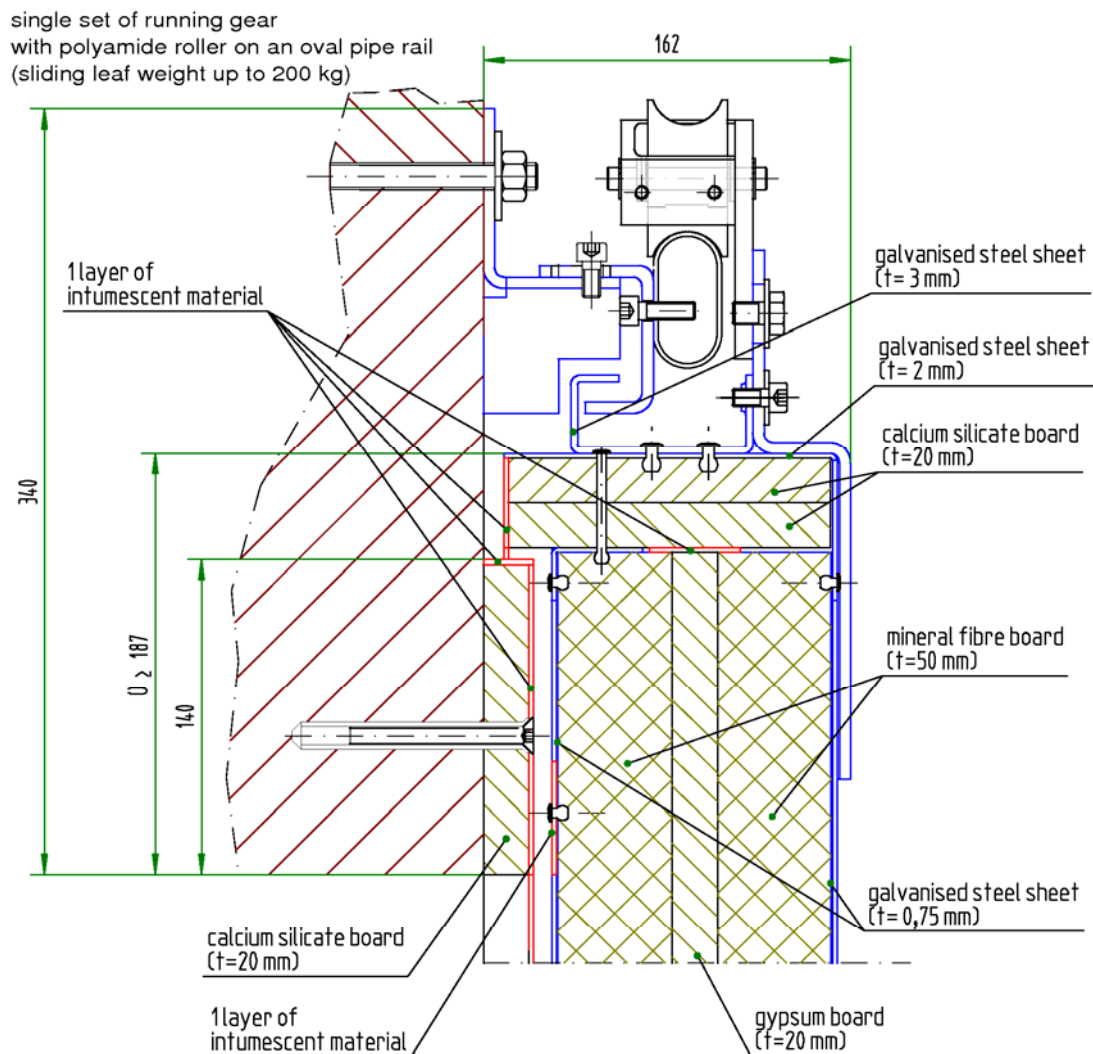

single set of running gear
with steel roller on a flat steel rail
(sliding leaf weight up to 400 kg)

double set of running gear
with steel rollers on a flat steel rail
(sliding leaf weight up to 800 kg)

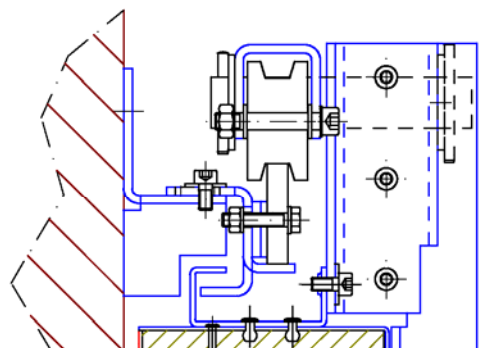
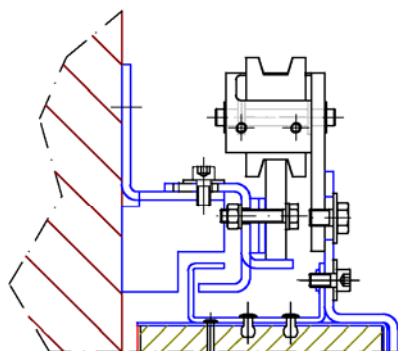

U = overlapping measure

Kit for closure systems "ECClos-S" for conveyor systems

Detail running rail / upper overlap
Horizontal closing direction
(dimensions in mm)

Annex 5

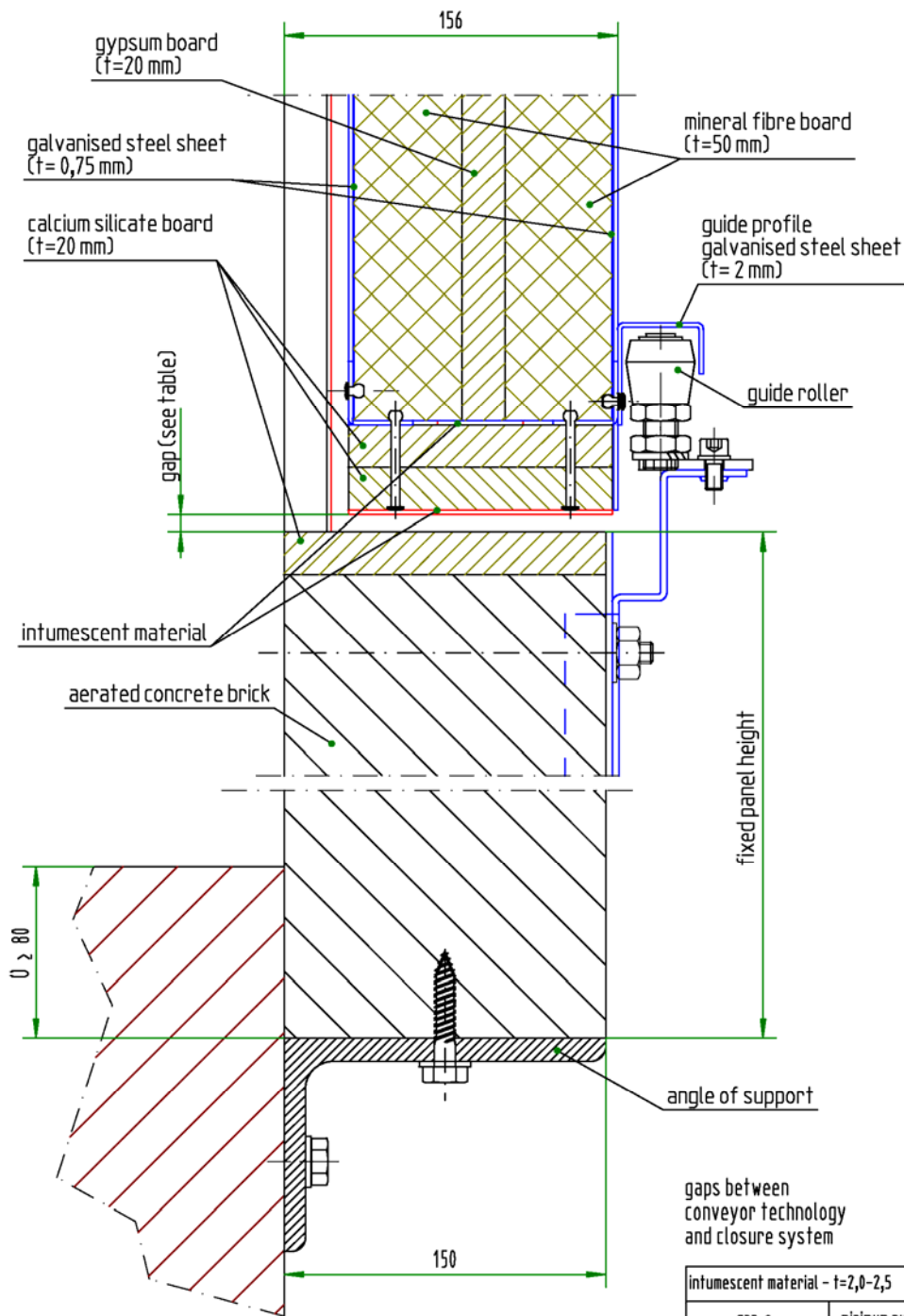

U = overlapping measure

Kit for closure systems "ECClos-S" for conveyor systems

Detail guide roller / lower overlap
Horizontal closing direction
(dimensions in mm)

Annex 6

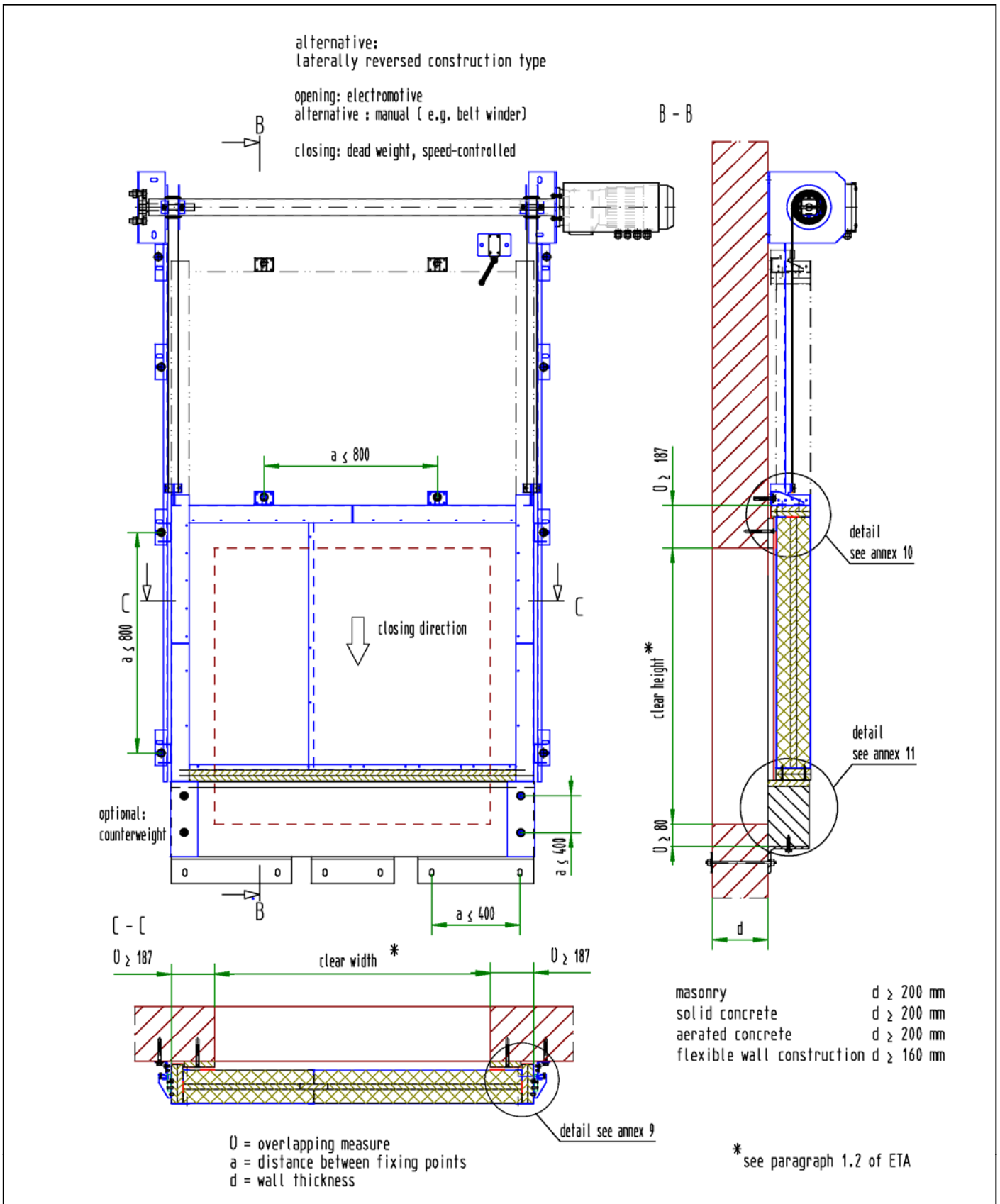

Kit for closure systems "ECClos-S" for conveyor systems

Overview
Vertical closing direction
(dimensions in mm)

Annex 7

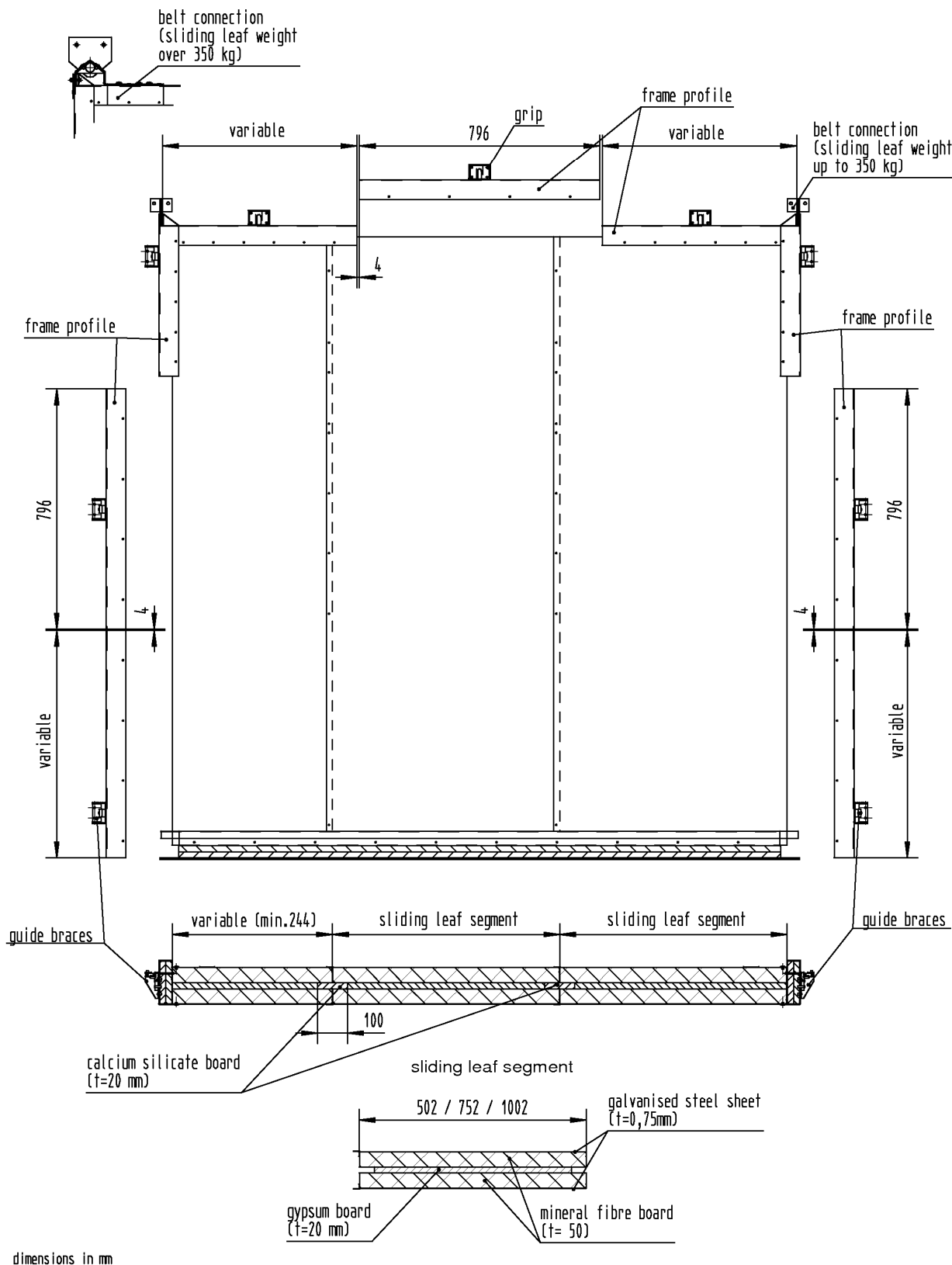

Kit for closure systems "ECClos-S" for conveyor systems

Sliding leaf construction
Vertical closing direction
(dimensions in mm)

Annex 8

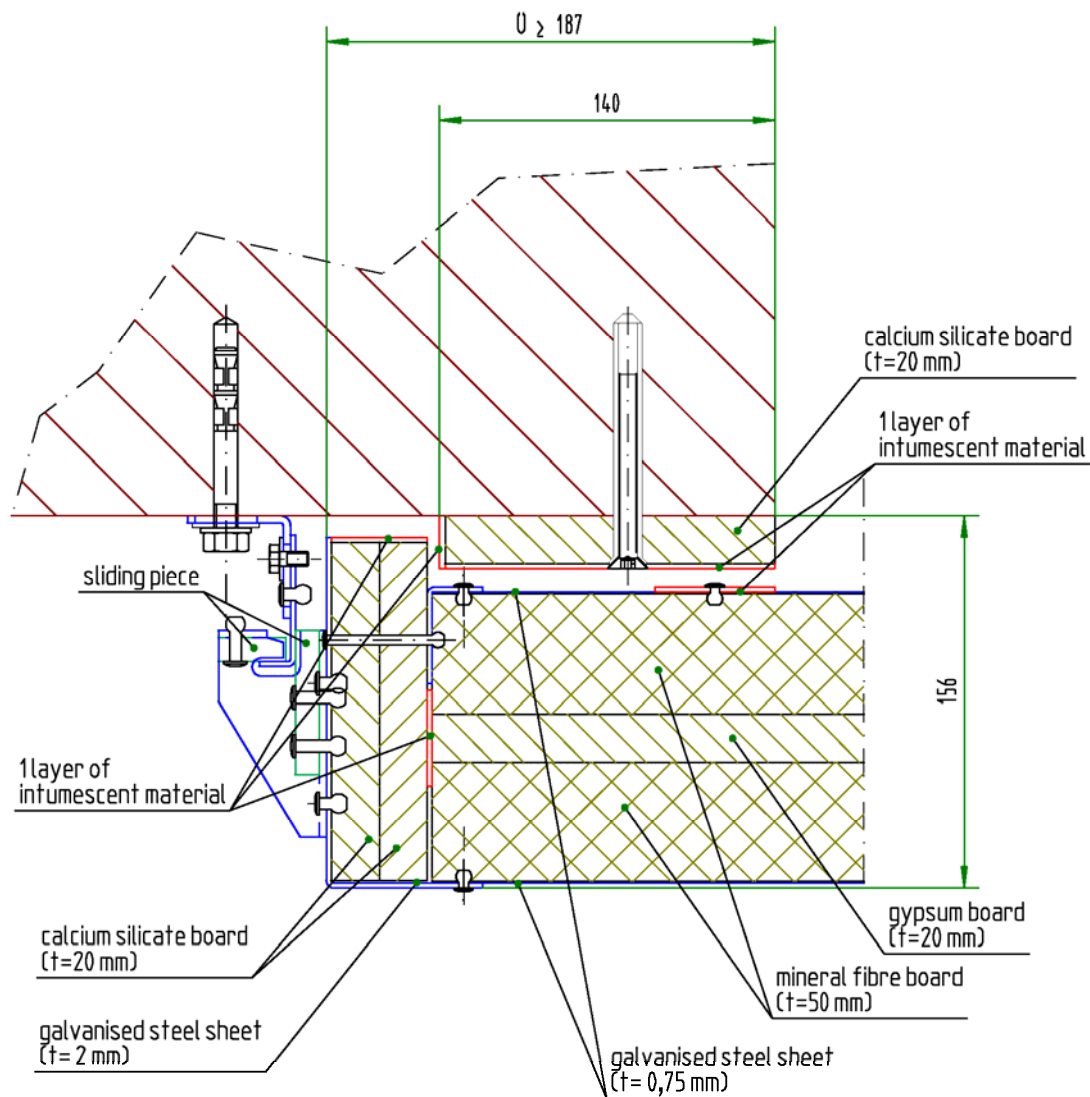

U = overlapping measure

Kit for closure systems "ECClos-S" for conveyor systems

Detail lateral overlap
Vertical closing direction
(dimensions in mm)

Annex 9

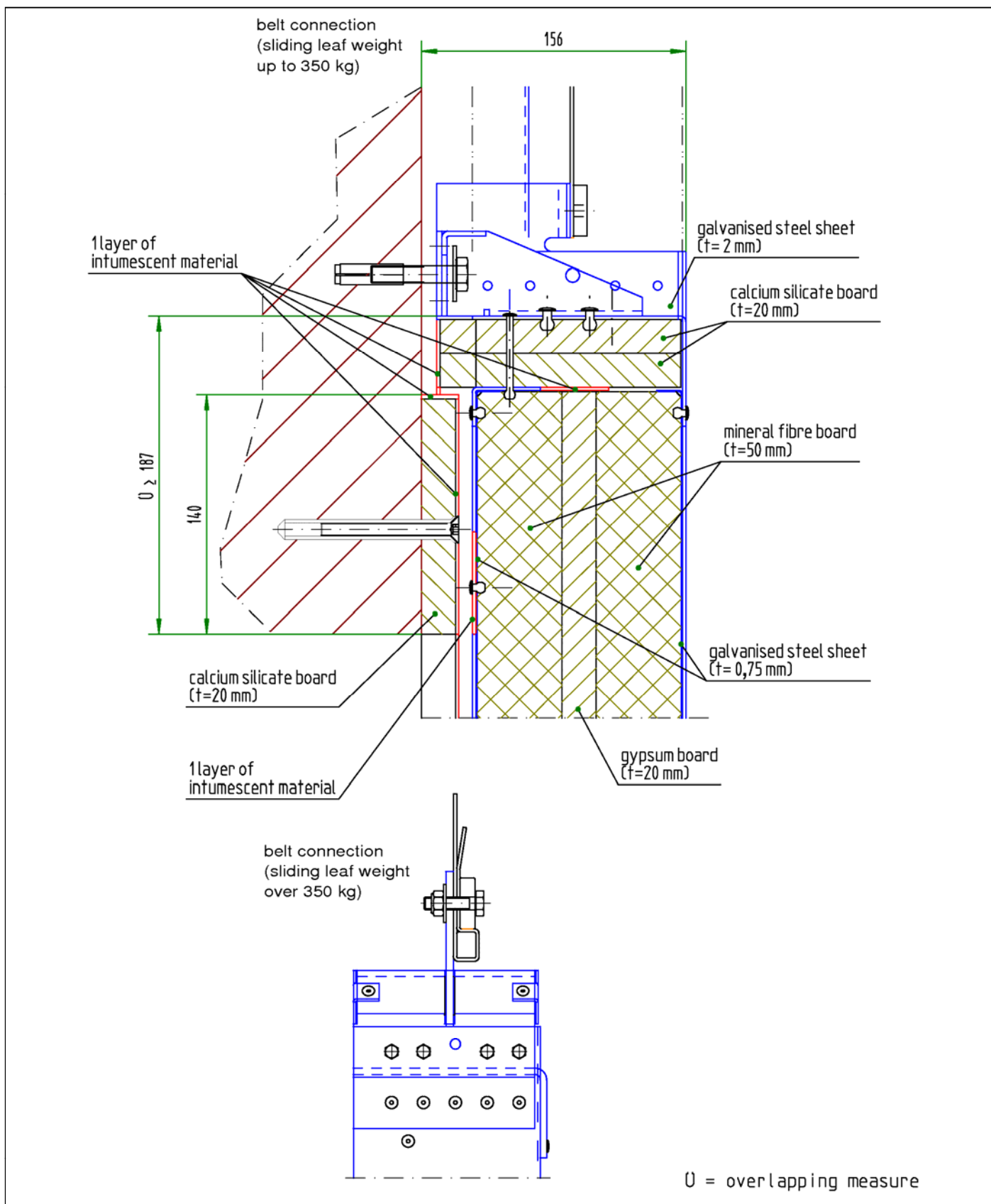

Kit for closure systems "ECClos-S" for conveyor systems

Detail upper overlap
Vertical closing direction
(dimensions in mm)

Annex 10

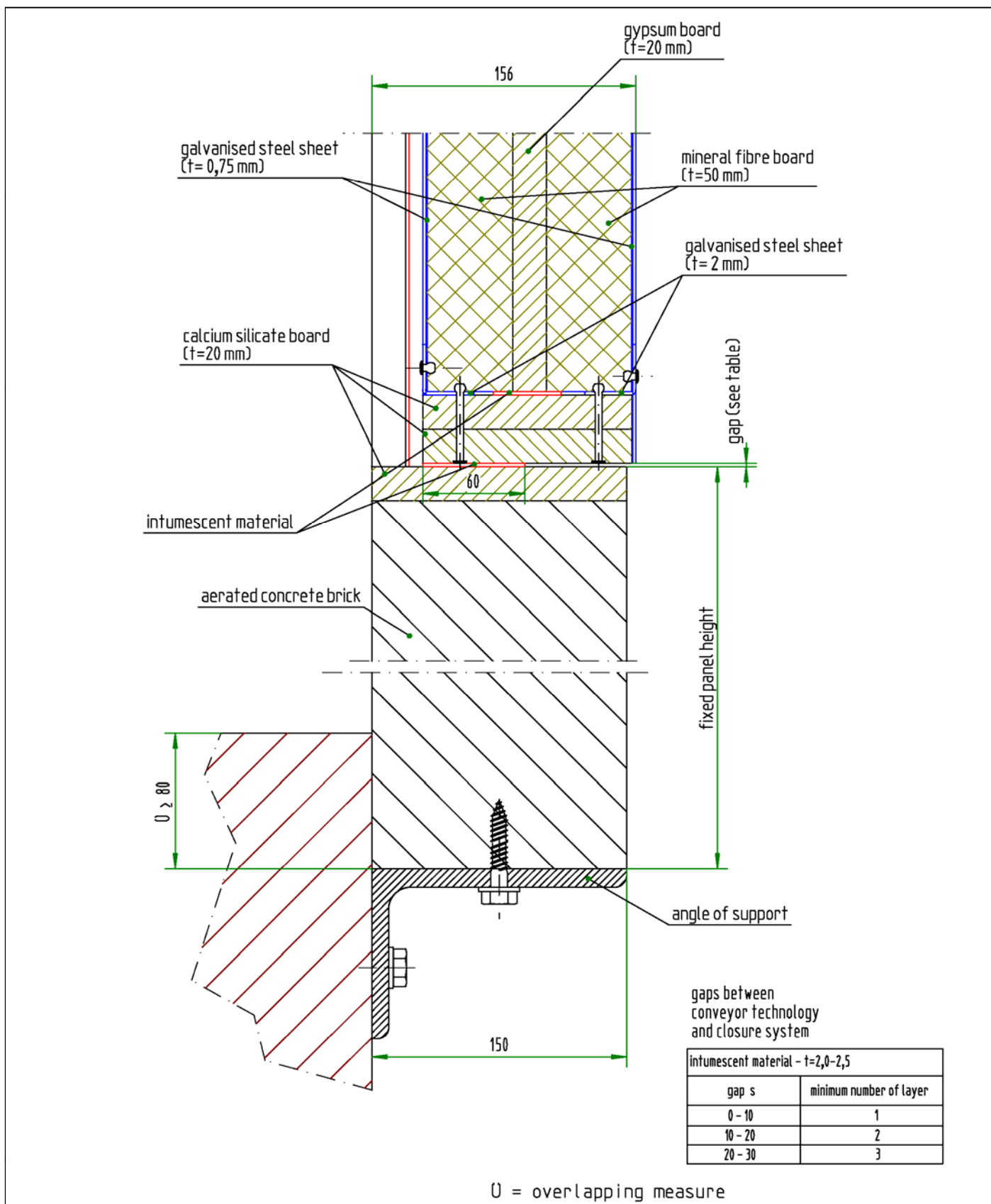

Kit for closure systems "ECClos-S" for conveyor systems

Detail lower overlap
Vertical closing direction
(dimensions in mm)

Annex 11

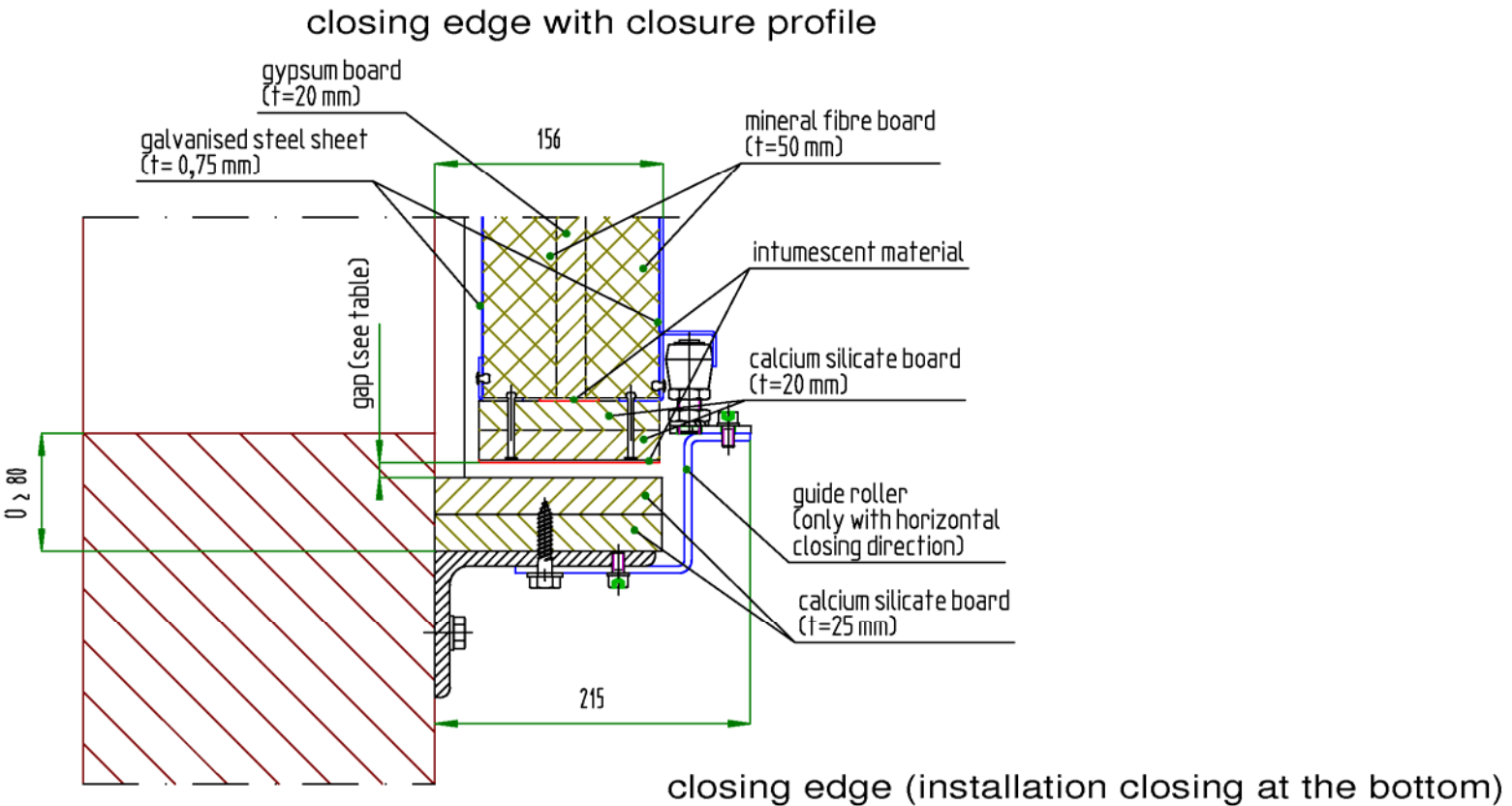

closing edge (installation closing at the bottom)

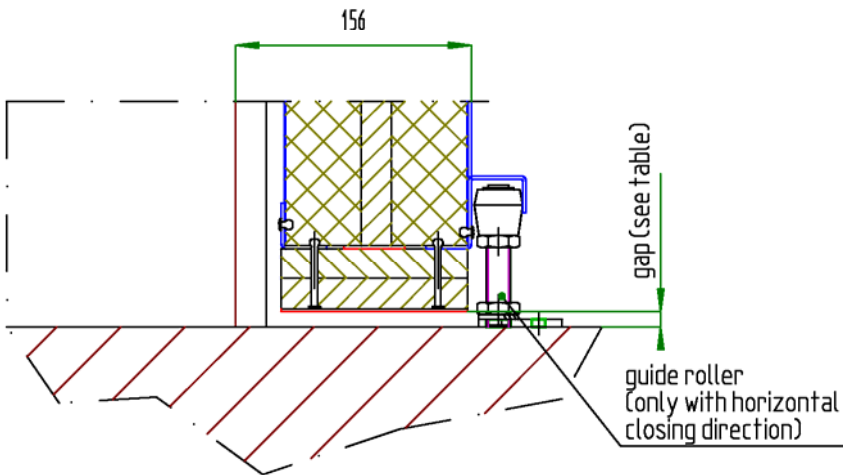

gaps at closing edge

intumescent material - t=2,0-2,5	
gap s	minimum number of layer
0 - 10	1
10 - 20	2

U = overlapping measure

Kit for closure systems "ECClos-S" for conveyor systems

Closing edge
Interrupted conveyor technology
(dimensions in mm)

Annex 12

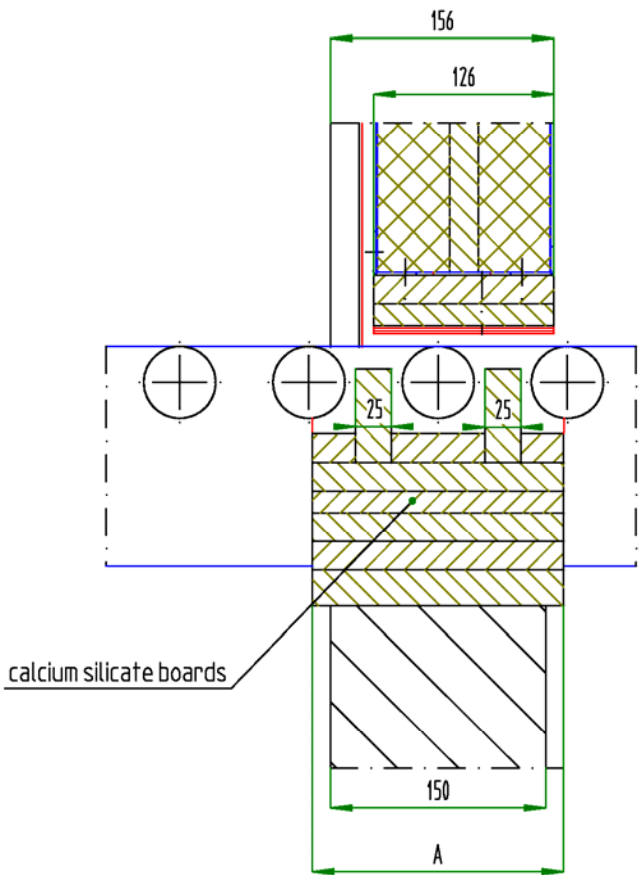

penetration seal depth A:
steel conveyor technology profiles A = 175 mm
aluminium conveyor technology profiles A = 250 mm

gaps between conveyor technology and closure system

intumescent material - t=2,0-2,5	
gap s	minimum number of layer
0 - 10	1
10 - 20	2
20 - 30	3

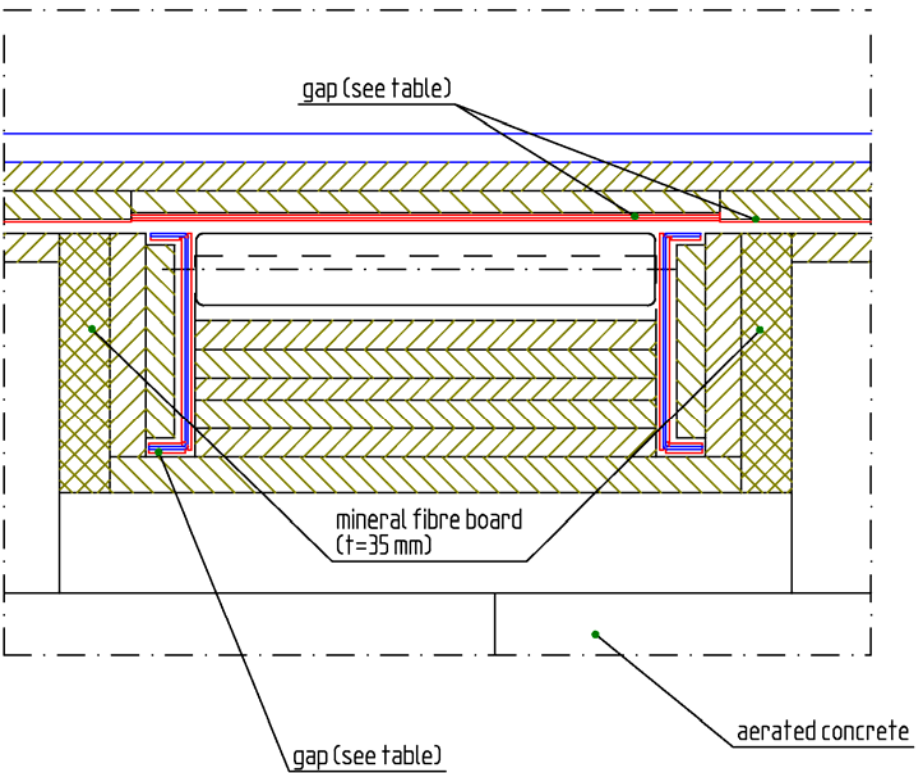

Kit for closure systems "ECClos-S" for conveyor systems

Closing edge
Roller conveyor
(dimensions in mm)

Annex 13

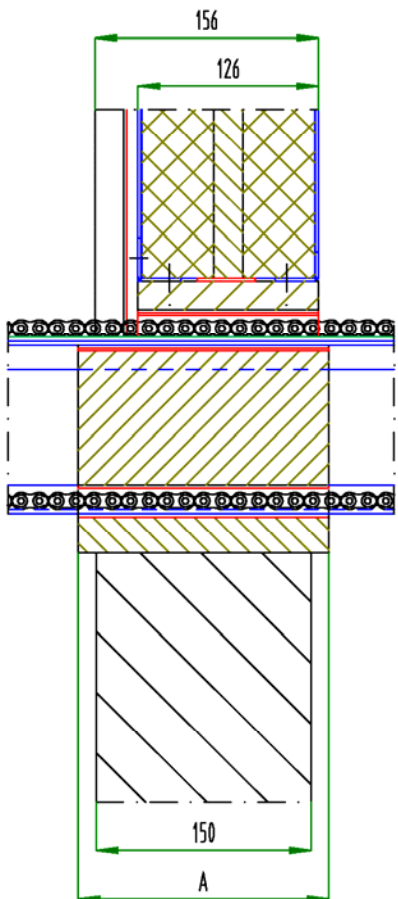

penetration seal depth A:
 steel conveyor technology profiles A = 175 mm
 aluminium conveyor technology profiles A = 250 mm

gaps between
conveyor technology
and closure system

intumescent material - t=2,0-2,5	
gap s	minimum number of layer
0 - 10	1
10 - 20	2
20 - 30	3

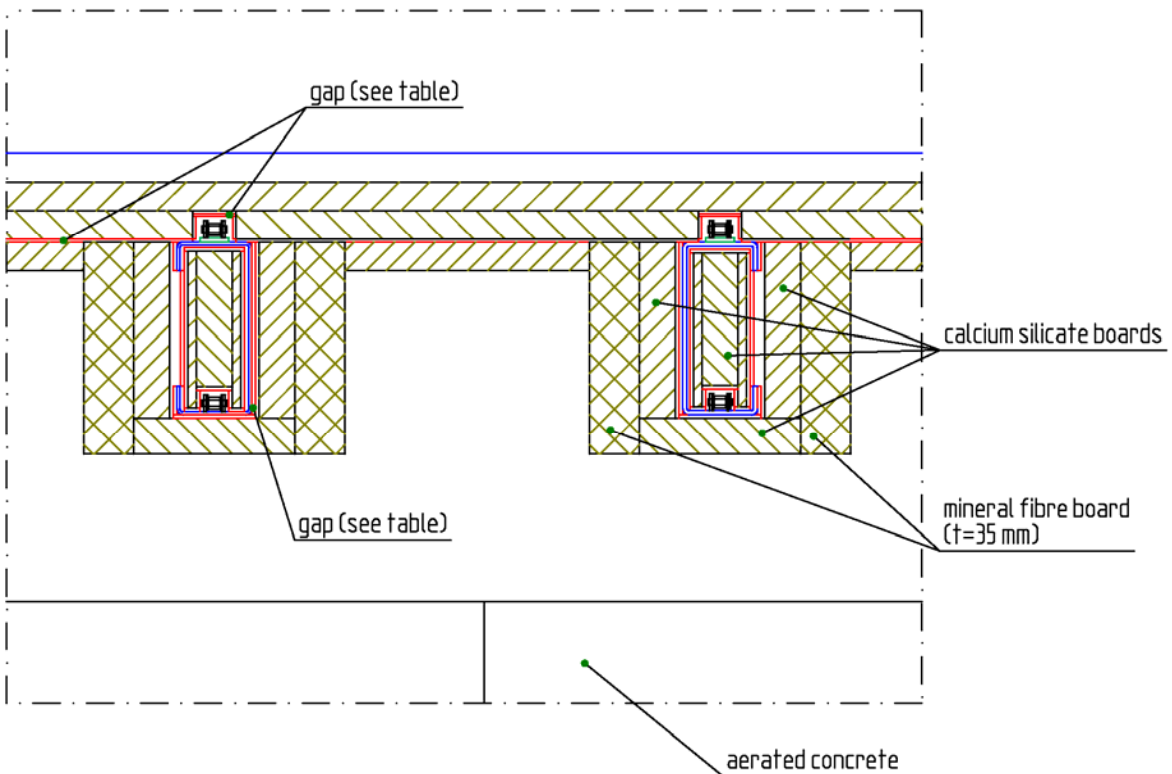

Kit for closure systems "ECClos-S" for conveyor systems

Closing edge
Chain conveyor
(dimensions in mm)

Annex 14

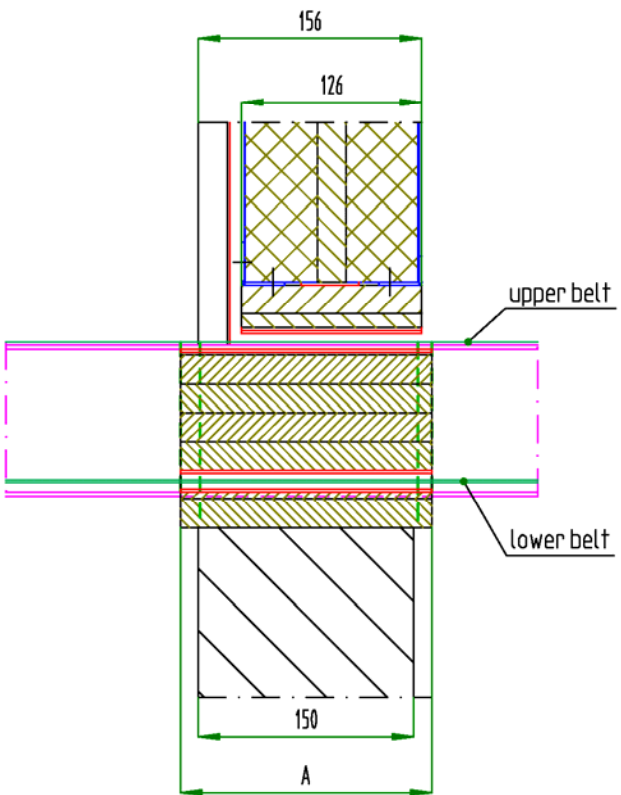

penetration seal depth A:
 steel conveyor technology profiles A = 175 mm
 aluminium conveyor technology profiles A = 250 mm

gaps between conveyor technology and closure system

intumescent material - t=2,0-2,5	
gap s	minimum number of layer
0 - 10	1
10 - 20	2
20 - 30	3

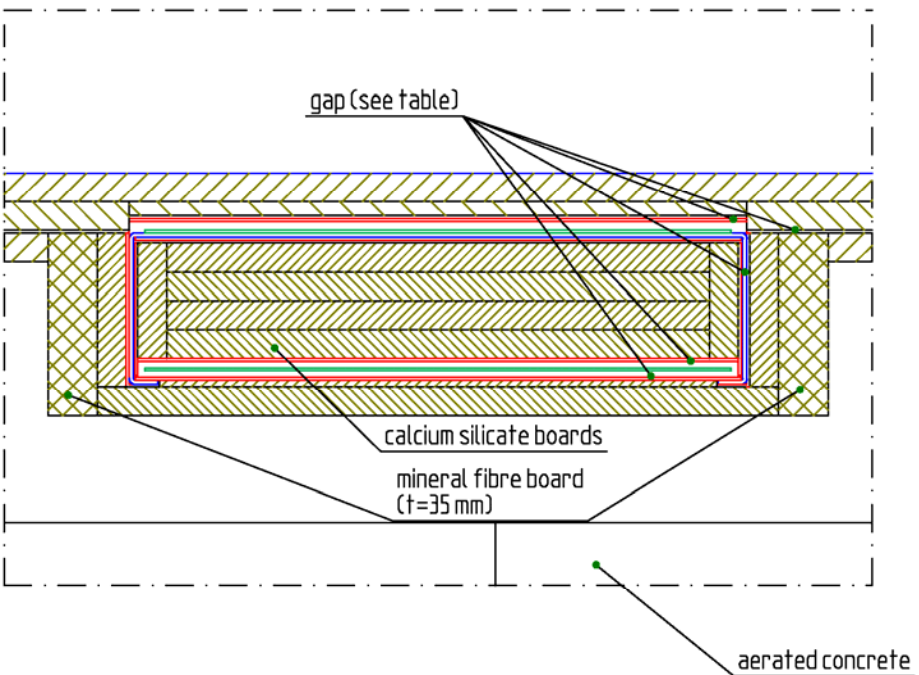

Kit for closure systems "ECClos-S" for conveyor systems

Closing edge
Belt conveyor
(dimensions in mm)

Annex 15

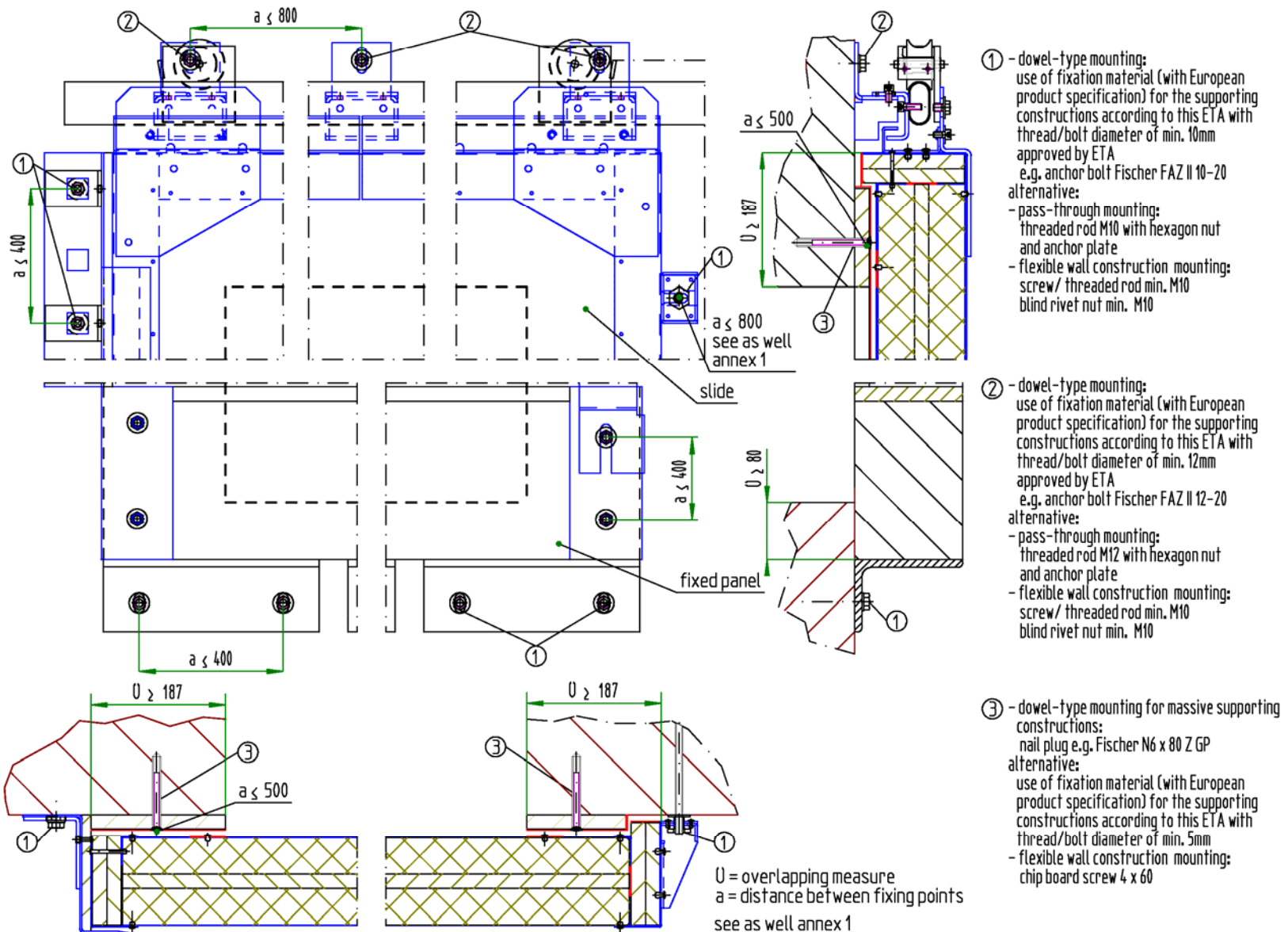

Kit for closure systems "ECClos-S" for conveyor systems

Installation
Horizontal closing direction
(dimensions in mm)

Annex 16

- ① - dowel-type mounting:
use of fixation material (with European product specification) for the supporting constructions according to this ETA with thread/bolt diameter of min. 10mm approved by ETA
e.g. anchor bolt Fischer FAZ II 10-20
alternative:
- pass-through mounting:
threaded rod M10 with hexagon nut and anchor plate
- flexible wall construction mounting:
screw/ threaded rod min. M10
blind rivet nut min. M10
- ② - dowel-type mounting:
use of fixation material (with European product specification) for the supporting constructions according to this ETA with thread/bolt diameter of min. 12mm approved by ETA
e.g. anchor bolt Fischer FAZ II 12-20
alternative:
- pass-through mounting:
threaded rod M12 with hexagon nut and anchor plate
- flexible wall construction mounting:
screw/ threaded rod min. M10
blind rivet nut min. M10
- ③ - dowel-type mounting for massive supporting constructions:
nail plug e.g. Fischer N6 x 80 Z GP
alternative:
use of fixation material (with European product specification) for the supporting constructions according to this ETA with thread/bolt diameter of min. 5mm
- flexible wall construction mounting:
chip board screw 4 x 60

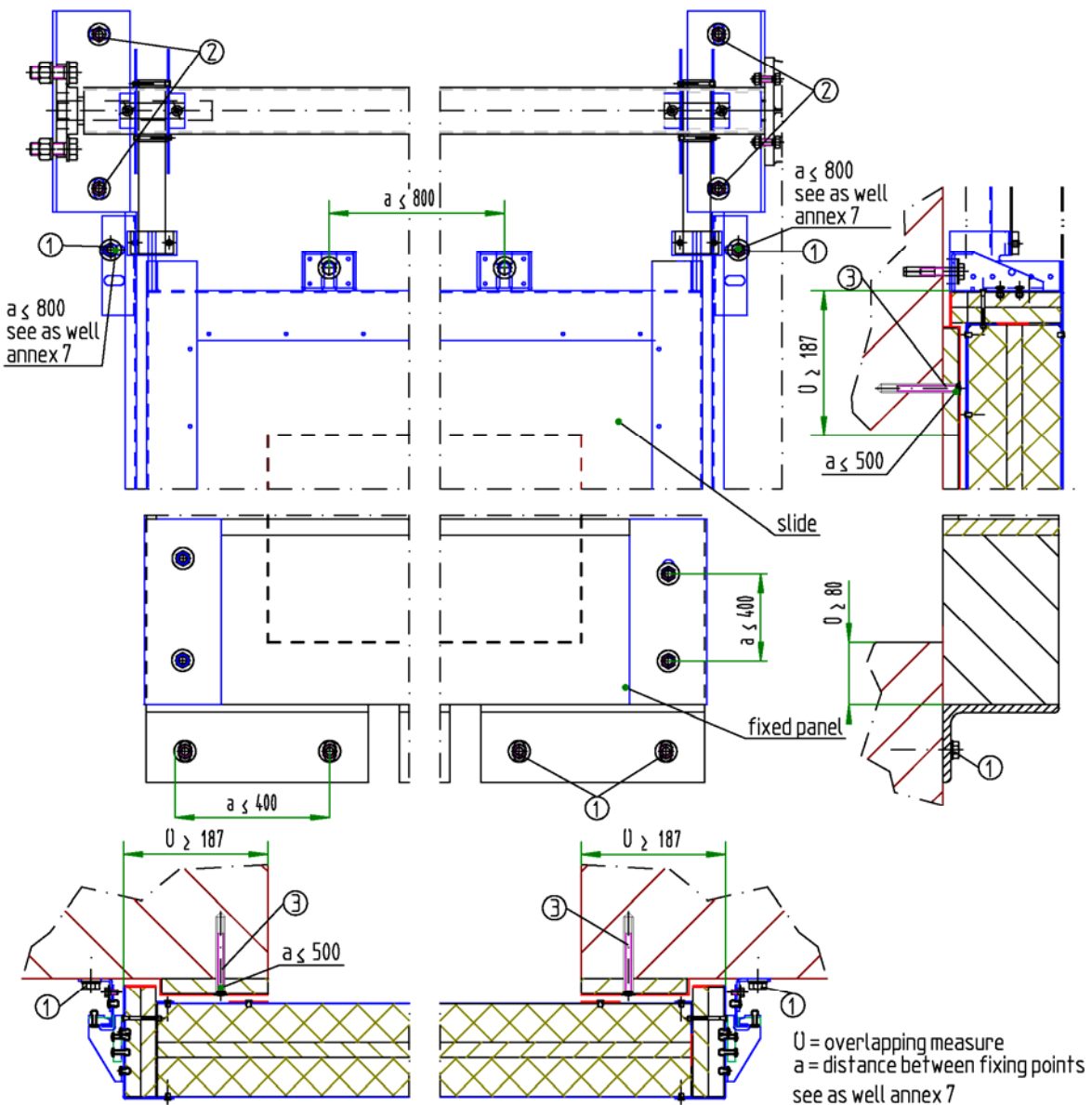

Kit for closure systems "ECClos-S" for conveyor systems

Installation
Vertical closing direction
(dimensions in mm)

Annex 17