

European Technical Approval ETA-11/0319

English translation prepared by DIBt - Original version in German language

Handelsbezeichnung <i>Trade name</i>	Tecfi Bolzenanker AJE <i>Tecfi wedge Anchor AJE</i>
Zulassungsinhaber <i>Holder of approval</i>	Tecfi S.p.A Strada Statale Appia, Km. 193 81050 PASTORANO (CE) ITALIEN
Zulassungsgegenstand und Verwendungszweck <i>Generic type and use of construction product</i>	Kraftkontrolliert spreizender Metaldübel Größen M8, M10, M12, M16 und M20 zur Verankerung in Beton <i>Torque controlled expansion anchor of sizes M8, M10, M12, M16 and M20 for use in concrete</i>
Geltungsdauer: <i>Validity:</i>	vom <i>from</i> bis <i>to</i> 1 November 2012 6 September 2016
Herstellwerk <i>Manufacturing plant</i>	tecfi plant

Diese Zulassung umfasst
This Approval contains

15 Seiten einschließlich 8 Anhänge
15 pages including 8 annexes

Diese Zulassung ersetzt
This Approval replaces

ETA-11/0319 mit Geltungsdauer vom 06.09.2011 bis 06.09.2016
ETA-11/0319 with validity from 06.09.2011 to 06.09.2016

I LEGAL BASES AND GENERAL CONDITIONS

- 1 This European technical approval is issued by Deutsches Institut für Bautechnik in accordance with:
 - Council Directive 89/106/EEC of 21 December 1988 on the approximation of laws, regulations and administrative provisions of Member States relating to construction products¹, modified by Council Directive 93/68/EEC² and Regulation (EC) N° 1882/2003 of the European Parliament and of the Council³;
 - *Gesetz über das In-Verkehr-Bringen von und den freien Warenverkehr mit Bauprodukten zur Umsetzung der Richtlinie 89/106/EWG des Rates vom 21. Dezember 1988 zur Angleichung der Rechts- und Verwaltungsvorschriften der Mitgliedstaaten über Bauprodukte und anderer Rechtsakte der Europäischen Gemeinschaften (Bauproduktengesetz - BauPG) vom 28. April 1998⁴, as amended by Article 2 of the law of 8 November 2011⁵;*
 - Common Procedural Rules for Requesting, Preparing and the Granting of European technical approvals set out in the Annex to Commission Decision 94/23/EC⁶;
 - Guideline for European technical approval of "Metal anchors for use in concrete - Part 2: Torque controlled expansion anchors ", ETAG 001-02.
- 2 Deutsches Institut für Bautechnik is authorized to check whether the provisions of this European technical approval are met. Checking may take place in the manufacturing plant. Nevertheless, the responsibility for the conformity of the products to the European technical approval and for their fitness for the intended use remains with the holder of the European technical approval.
- 3 This European technical approval is not to be transferred to manufacturers or agents of manufacturers other than those indicated on page 1, or manufacturing plants other than those indicated on page 1 of this European technical approval.
- 4 This European technical approval may be withdrawn by Deutsches Institut für Bautechnik, in particular pursuant to information by the Commission according to Article 5(1) of Council Directive 89/106/EEC.
- 5 Reproduction of this European technical approval including transmission by electronic means shall be in full. However, partial reproduction can be made with the written consent of Deutsches Institut für Bautechnik. In this case partial reproduction has to be designated as such. Texts and drawings of advertising brochures shall not contradict or misuse the European technical approval.
- 6 The European technical approval is issued by the approval body in its official language. This version corresponds fully to the version circulated within EOTA. Translations into other languages have to be designated as such.

¹ Official Journal of the European Communities L 40, 11 February 1989, p. 12

² Official Journal of the European Communities L 220, 30 August 1993, p. 1

³ Official Journal of the European Union L 284, 31 October 2003, p. 25

⁴ *Bundesgesetzblatt Teil I 1998*, p. 812

⁵ *Bundesgesetzblatt Teil I 2011*, p. 2178

⁶ Official Journal of the European Communities L 17, 20 January 1994, p. 34

II SPECIFIC CONDITIONS OF THE EUROPEAN TECHNICAL APPROVAL

1 Definition of product and intended use

1.1 Definition of the construction product

The Tecfi Wedge anchor AJE is an anchor made of galvanised steel of sizes M8, M10, M12, M16 and M20 which is placed into a drilled hole and anchored by torque-controlled expansion.

An illustration of the product and intended use is given in Annex 1.

1.2 Intended use

The anchor is intended to be used for anchorages for which requirements for mechanical resistance and stability and safety in use in the sense of the Essential Requirements 1 and 4 of Council Directive 89/106 EEC shall be fulfilled and failure of anchorages made with these products would cause risk to human life and/or lead to considerable economic consequences.

The anchor may be used for anchorages with requirements related to resistance to fire.

The anchor is to be used only for anchorages subject to static or quasi-static loading in reinforced or unreinforced normal weight concrete of strength classes C20/25 at minimum and C50/60 at most according to EN 206:2000-12.

It may be anchored in cracked and non-cracked concrete.

The anchor may only be used in structures subject to dry internal conditions.

The provisions made in this European technical approval are based on an assumed working life of the anchor of 50 years. The indications given on the working life cannot be interpreted as a guarantee given by the producer, but are to be regarded only as a means for choosing the right products in relation to the expected economically reasonable working life of the works.

2 Characteristics of the product and methods of verification

2.1 Characteristics of the product

The anchor corresponds to the drawings and provisions given in Annexes 2 to 4. The characteristic material values, dimensions and tolerances of the anchor not given in Annexes 2 to 4 shall correspond to the respective values laid down in the technical documentation⁷ of this European technical approval.

Regarding the requirements concerning safety in case of fire it is assumed that the anchor meets the requirements of class A1 in relation to reaction to fire in accordance with the stipulations of the Commission decision 96/603/EC, amended by 2000/605/EC.

The characteristic values for the design of anchorages are given in Annexes 5 and 6.

⁷ The technical documentation of this European technical approval is deposited at the Deutsches Institut für Bautechnik and, as far as relevant for the tasks of the approved bodies involved in the attestation of conformity procedure, is handed over to the approved bodies.

The characteristic values for the design of anchorages regarding resistance to fire are given in the Annexes 7 and 8. They are valid for use in a system that is required to provide a specific fire resistance class.

Each cone bolt is marked with the identifying mark of the producer, the trade name, the anchor diameter, the anchor length and the maximum thickness of fixture according to Annex 2. Each expansion sleeve is marked with the thread diameter.

The anchor shall only be packaged and supplied as a complete unit.

2.2 Methods of verification

The assessment of fitness of the anchor for the intended use in relation to the requirements for mechanical resistance and stability and safety in use in the sense of the Essential Requirements 1 and 4 has been made in accordance with the "Guideline for European technical approval of Metal Anchors for Use in Concrete", Part 1 "Anchors in general" and Part 2 "Torque-controlled expansion anchors", on the basis of Option 1.

The assessment of the anchor for the intended use in relation to the requirements for resistance to fire has been made in accordance with the Technical Report TR 020 "Evaluation of anchorages in concrete concerning resistance to fire".

In addition to the specific clauses relating to dangerous substances contained in this European technical approval, there may be other requirements applicable to the products falling within its scope (e.g. transposed European legislation and national laws, regulations and administrative provisions). In order to meet the provisions of the Construction Products Directive, these requirements need also to be complied with, when and where they apply.

3 Evaluation and attestation of conformity and CE marking

3.1 System of attestation of conformity

According to the decision 96/582/EG of the European Commission⁸ the system 2(i) (referred to as system 1) of attestation of conformity applies.

System 1: Certification of the conformity of the product by an approved certification body on the basis of:

(a) Tasks for the manufacturer:

- (1) factory production control;
- (2) further testing of samples taken at the factory by the manufacturer in accordance with a prescribed control plan;

(b) Tasks for the approved body:

- (3) initial type-testing of the product;
- (4) initial inspection of factory and of factory production control;
- (5) continuous surveillance, assessment and approval of factory production control.

Note: Approved bodies are also referred to as "notified bodies".

⁸

Official Journal of the European Communities L 254 of 08.10.1996.

3.2 Responsibilities

3.2.1 Tasks of the manufacturer

3.2.1.1 Factory production control

The manufacturer shall exercise permanent internal control of production. All the elements, requirements and provisions adopted by the manufacturer shall be documented in a systematic manner in the form of written policies and procedures, including records of results performed. This production control system shall insure that the product is in conformity with this European technical approval.

The manufacturer may only use initial/raw/constituent materials stated in the technical documentation of this European technical approval.

The factory production control shall be in accordance with the control plan which is part of the technical documentation of this European technical approval. The control plan is laid down in the context of the factory production control system operated by the manufacturer and deposited at Deutsches Institut für Bautechnik⁹.

The results of factory production control shall be recorded and evaluated in accordance with the provisions of the control plan.

3.2.1.2 Other tasks of manufacturer

The manufacturer shall, on the basis of a contract, involve a body which is approved for the tasks referred to in section 3.1 in the field of anchors in order to undertake the actions laid down in section 3.2.2. For this purpose, the control plan referred to in sections 3.2.1.1 and 3.2.2 shall be handed over by the manufacturer to the approved body involved.

The manufacturer shall make a declaration of conformity, stating that the construction product is in conformity with the provisions of this European technical approval.

3.2.2 Tasks of approved bodies

The approved body shall perform the

- initial type-testing of the product,
- initial inspection of factory and of factory production control,
- continuous surveillance, assessment and approval of factory production control

in accordance with the provisions laid down in the control plan.

The approved body shall retain the essential points of its actions referred to above and state the results obtained and conclusions drawn in a written report.

The approved certification body involved by the manufacturer shall issue an EC certificate of conformity of the product stating the conformity with the provisions of this European technical approval.

In cases where the provisions of the European technical approval and its control plan are no longer fulfilled the certification body shall withdraw the certificate of conformity and inform Deutsches Institut für Bautechnik without delay.

⁹ The control plan is a confidential part of the documentation of the European technical approval, but not published together with the European technical approval and only handed over to the approved body involved in the procedure of attestation of conformity.
See section 3.2.2.

3.3 CE marking

The CE marking shall be affixed on each packaging of the anchor. The letters "CE" shall be followed by the identification number of the approved certification body, where relevant, and be accompanied by the following additional information:

- the name and address of the producer (legal entity responsible for the manufacturer),
- the last two digits of the year in which the CE marking was affixed,
- the number of the EC certificate of conformity for the product,
- the number of the European technical approval,
- the number of the guideline for European technical approval,
- use category (ETAG 001-1 Option 1),
- size.

4 Assumptions under which the fitness of the product for the intended use was favourably assessed

4.1 Manufacturing

The European technical approval is issued for the product on the basis of agreed data/information, deposited with the Deutsches Institut für Bautechnik, which identifies the product that has been assessed and judged. Changes to the product or production process, which could result in this deposited data/information being incorrect, should be notified to the Deutsches Institut für Bautechnik before the changes are introduced. Deutsches Institut für Bautechnik will decide whether or not such changes affect the approval and consequently the validity of the CE marking on the basis of the approval and if so whether further assessment or alterations to the approval shall be necessary.

4.2 Design of anchorages

The fitness of the anchor for the intended use is given under the following conditions:

The anchorages are designed in accordance with the "Guideline for European technical approval of Metal Anchors for Use in Concrete", Annex C, Method A, under the responsibility of an engineer experienced in anchorages and concrete work.

Verifiable calculation notes and drawings are taking account of the loads to be anchored.

The position of the anchor is indicated on the design drawings (e.g. position of the anchor relative to reinforcement or to supports).

The design of anchorages under fire exposure has to consider the conditions given in the Technical Report TR 020 "Evaluation of anchorages in concrete concerning resistance to fire". The relevant characteristic anchor values are given in Annexes 7 and 8. The design method covers anchors with a fire attack from one side only. If the fire attack is from more than one side, the design method may be taken only, if the edge distance of the anchor is $c \geq 300$ mm.

4.3 Installation of anchors

The fitness for use of the anchor can only be assumed if the anchor is installed as follows:

- Anchor installation carried out by appropriately qualified personnel and under the supervision of the person responsible for technical matters of the site,
- Use of the anchor only as supplied by the manufacturer without exchanging the components of an anchor,
- Anchor installation in accordance with the manufacturer's specifications and drawings and using the appropriate tools,
- Checks before placing the anchor to ensure that the strength class of the concrete in which the anchor is to be placed is in the range given and is not lower than that of the concrete to which the characteristic loads apply,
- Check of concrete being well compacted, e.g. without significant voids,
- Edge distances and spacing not less than the specified values without minus tolerances,
- Positioning of the drill holes without damaging the reinforcement,
- In case of aborted hole: new drilling at a minimum distance away of twice the depth of the aborted hole or smaller distance if the aborted drill hole is filled with high strength mortar and if under shear or oblique tension load it is not in the direction of load application,
- Cleaning of the hole of drilling dust,
- Anchor installation such that the effective anchorage depth is complied with. This compliance is ensured when the embedment mark of the anchor does no more exceed the concrete surface,
- Application of the torque moment given in Annex 3 using a calibrated torque wrench.

5 Indications to the manufacturer

The manufacturer is responsible to ensure that the information on the specific conditions according to 1 and 2 including Annexes referred to as well as sections 4.2 and 4.3 is given to those who are concerned. This information may be made by reproduction of the respective parts of the European technical approval. In addition all installation data shall be shown clearly on the package and/or on an enclosed instruction sheet, preferably using illustration(s).

The minimum data required are:

- Diameter of drill bit,
- Thread diameter,
- Maximum thickness of the fixture,
- Minimum effective anchorage depth,
- Minimum hole depth,
- Torque moment,
- Information on the installation procedure, including cleaning of the hole, preferably by means of an illustration,
- Reference to any special installation equipment needed,
- Identification of the manufacturing batch.

All data shall be presented in a clear and explicit form.

Andreas Kummerow
p. p. Head of Department

beglaubigt:
E. Aksünger

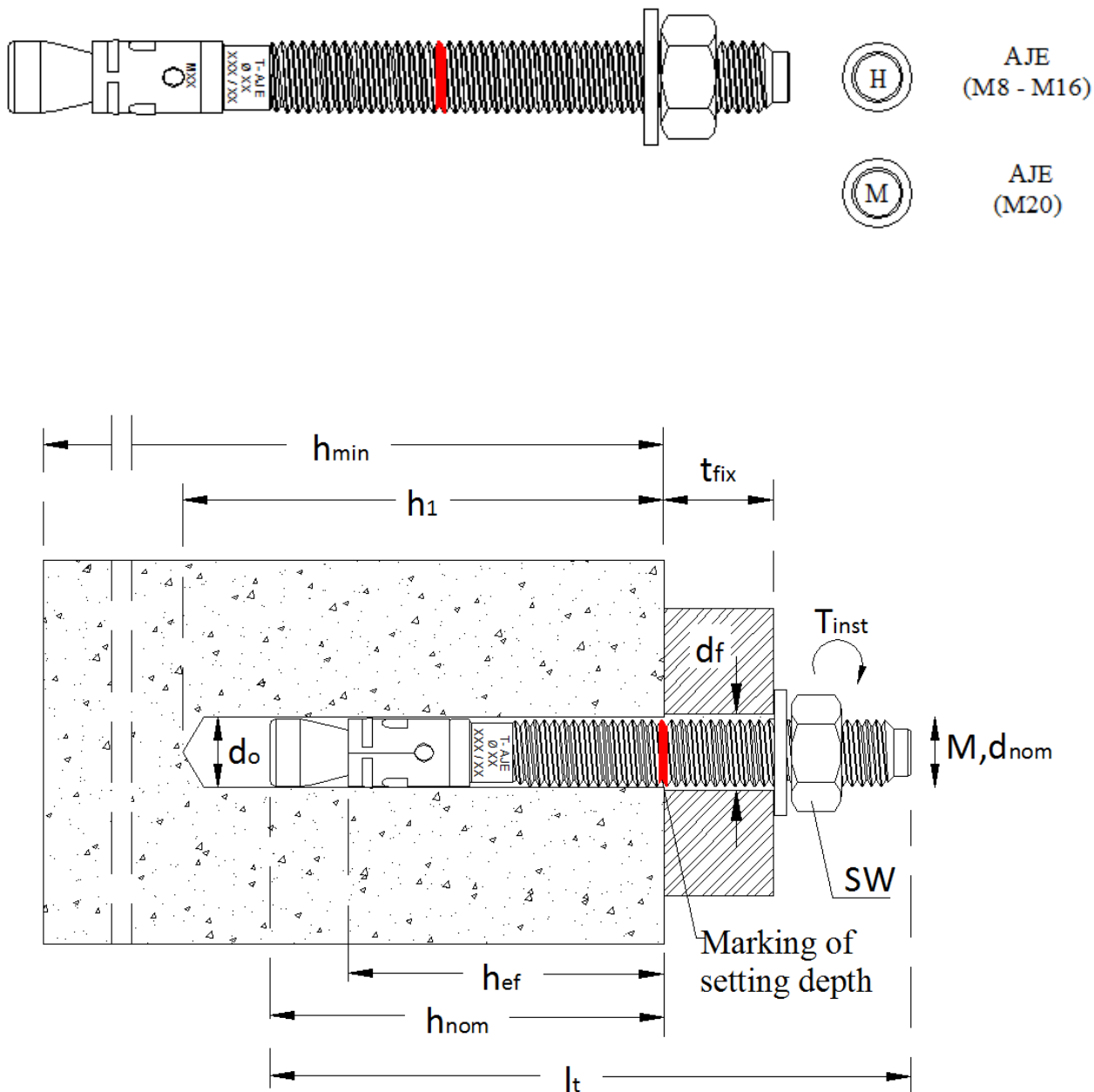

Tecfi wedge Anchor AJE

Product and intended use

Annex 1

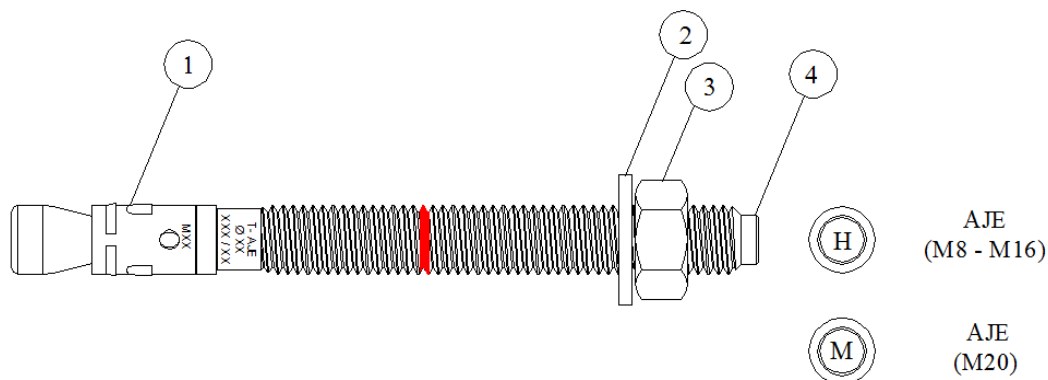

Marking

Cone Bolt:

- Identifying mark of producer
 - Trade name
 - Anchor diameter
 - Anchor length / Maximum thickness of fixture
 - e.g. : T-AJE
 $\phi 8$
 110/40
- Letter code on the head of the cone bolt (maximum thickness of fixture)
 - e.g.: H (for anchor diameter M8 and M16)

Expansion sleeve:

- Thread diameter
- e.g.: M8

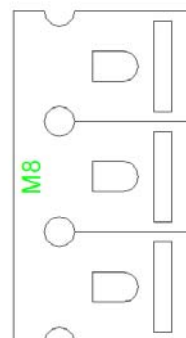

Table 1 : Designation of anchor parts and materials

Part	Description	Materials galvanised $\geq 5\mu\text{m}$ according to ISO 4042
1	Sleeve expansion	Steel, HRB 80
2	Washer	Steel, ISO 7089 ¹⁾ , HV 200.
3	Hexagonal nut	Steel, Strength class 8, EN ISO 898-2
4	Cone bolt	Steel ²⁾ , Tensile strength min. 800 N/mm ²

¹⁾ On request can be used washer according to ISO 7093-1, HV 200

²⁾ Functional coating

Tecfi wedge Anchor AJE

Designation of anchor parts and Materials

Annex 2

Table 2 : Installation parameters

Type of anchor / Size		AJE M8	AJE M10	AJE M12	AJE M16	AJE M20
Nominal drill hole diameter	$d_o = [mm]$	8	10	12	16	20
Cutting diameter of drill bit	$d_{cut} \leq [mm]$	8.45	10.45	12.50	16.50	20.55
Effective anchorage depth	$h_{ef} = [mm]$	45	55	70	85	100
Depth of drill hole	$h_1 = [mm]$	65	85	105	120	135
Diameter of clearance in the fixture	$d_f = [mm]$	9	12	14	18	20
Overall anchor embedment depth in the concrete	$h_{nom} = [mm]$	55	70	85	100	115
Installation torque moment	$T_{inst} = [Nm]$	20	45	60	110	200
Minimum thickness of concrete member	$h_{min} = [mm]$	100	110	140	170	200
Outside diameter of anchor	$d_{nom} = [mm]$	8	10	12	16	20
Wrench Size	SW = [mm]	13	17	19	24	30
Minimum edge distance	$c_{min} = [mm]$	80	65	75	130	100
Minimum spacing	$s_{min} = [mm]$	80	80	90	130	200

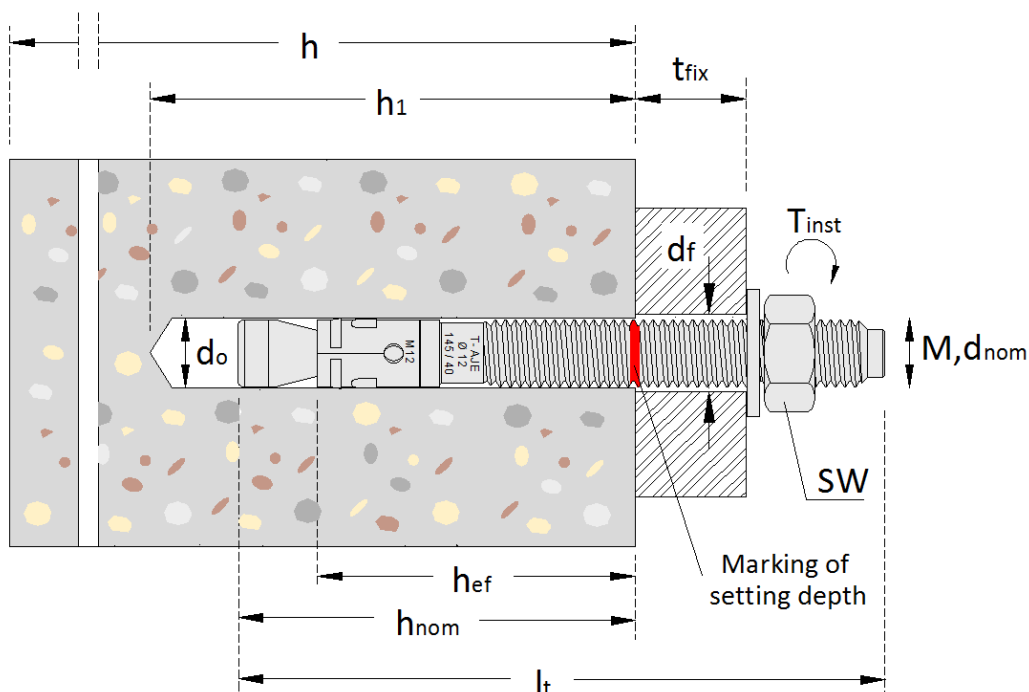

Tecfi wedge Anchor AJe

Installation parameters, minimum edge distance and spacing

Annex 3

Table 3 : Installation parameters

Type of anchor / Size		AJE M8	AJE M10	AJE M12	AJE M16	AJE M20
Thickness of fixture	$t_{fix,min} = [mm]$	10	10	10	5	30
	$t_{fix,max} = [mm]$	160	160	270	320	160
Length of anchor	$l_{tmin} = [mm]$	80	95	115	130	170
	$l_{tmax} = [mm]$	230	245	375	445	300

Table 4 : Letter code

Letter code on the head of cone bolt *	A	B	C	D	E	F	G	H	I	K	L	M	N	O	P	R	S
Maximum thickness of fixture	5	10	15	20	25	30	35	40	45	50	55	60	65	70	80	90	100

*For 100<math>t_{fix}<math>\leq 200 there is the number 1 before than the letter code
200<math>t_{fix}<math>\leq 300 there is the number 2 before than the letter code
300<math>t_{fix}<math>\leq 400 there is the number 3 before than the letter code

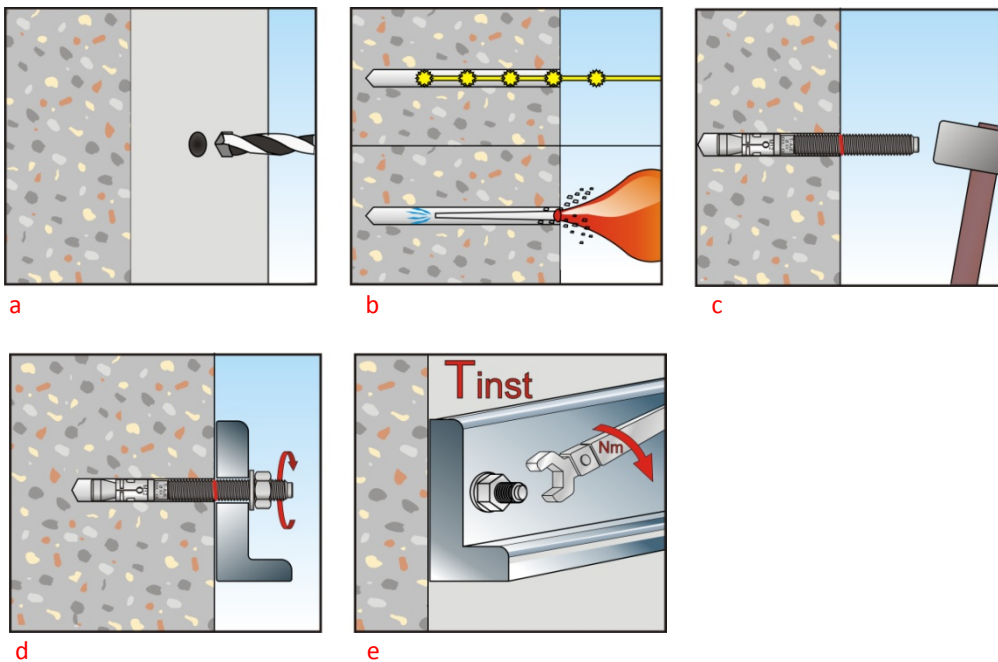

- Make a drill hole with a hammer drilling.
- Clean the drill hole with a brush.
- Put the anchor into the drill hole.
- Placing the fixture.
- Apply the required installation torque.

Tecfi wedge Anchor AJE

Installation parameters and installation instruction

Annex 4

Table 5 : Design Method A, Characteristic values to tension loads

Type of anchor / Size			AJE M8	AJE M10	AJE M12	AJE M16	AJE M20
Steel failure							
Characteristic Resistance	$N_{Rk,s}$	[kN]	16	25	40	70	115
Partial safety factor	$\gamma_{Ms}^{1)}$	[kN]	1,5				
Pull-out failure							
Effective embedment depth	h_{ef}	[mm]	45	55	70	75	90
Characteristic Resistance in uncracked concrete C20/25	$N_{Rk,p}$	[kN]	7.5	16	20	30	40
Characteristic Resistance in cracked concrete C20/25			6	9	16	25	30
Increasing factors for $N_{Rk,p}$ for cracked and uncracked concrete	Ψ_c	C30/37	1.22				
		C40/50	1.41				
		C50/60	1.55				
Partial safety factor	$\gamma_{Mp}^{1)}$	[-]	1.8 ²⁾			1.5 ³⁾	
Concrete cone failure and splitting failure							
Effective embedment depth	h_{ef}	[mm]	45	55	70	75	90
Spacing	$s_{cr,N}$	[mm]	135	165	210	255	300
Edge distance	$c_{cr,N}$	[mm]	68	85	105	128	150
Spacing (splitting)	$s_{cr,sp}$	[mm]	200	280	300	430	400
Edge distance (splitting)	$c_{cr,sp}$	[mm]	100	140	150	215	200
Partial safety factor	$\gamma_{Mp}^{1)}$	[-]	1.8 ²⁾			1.5 ³⁾	

¹⁾ In absence of other national regulations.

²⁾ The partial safety factor $\gamma_2=1.2$ is included

³⁾ The partial safety factor $\gamma_2=1.0$ is included

Table 6 : Displacements under tension loads

Type of anchor / Size			AJE M8	AJE M10	AJE M12	AJE M16	AJE M20
Service tension load in uncracked concrete C20/25	N	[kN]	3.3	6.4	7.9	16.7	23.3
Displacements	δ_{N0}	[mm]	0.02	0.01	0.02	0.09	0.06
	$\delta_{N\infty}$	[mm]	-	-	0.03	-	-
Service tension load in cracked concrete C20/25	N	[kN]	2.4	3.6	6.4	11.9	16.7
Displacements	δ_{N0}	[mm]	0.13	0.06	0.60	0.27	0.45
	$\delta_{N\infty}$	[mm]	1.02	0.20	0.84	1.40	0.55

Tecfi wedge Anchor AJE

Design Method A,
Characteristic values of resistance and
displacement under tension loads

Annex 5

Table 7 : Design Method A, Characteristic values to shear loads

Type of anchor / Size			AJE M8	AJE M10	AJE M12	AJE M16	AJE M20
Steel failure without lever arm							
Characteristic Resistance	$V_{Rk,s}$	[kN]	12	20	35	60	95
Partial safety factor	$\gamma_{Ms}^{1)}$	[kN]	1.5				
Steel failure with lever arm							
Characteristic bending moment	$M_{Rk,s}^0$	[Nm]	30	60	105	266	519
Partial safety factor	$\gamma_{Ms}^{1)}$	[-]	1.5				
Concrete pryout failure							
Effective embedment depth	h_{ef}	[mm]	45	55	70	75	90
Factor in equation (5.6) of the guideline Annex C, Section 5.2.3.3	k	[-]	1		2		
Partial safety factor	$\gamma_{Mp}^{1)}$	[-]	1.5 ²⁾				
Concrete edge failure							
Effective anchorage length	l_{ef}	[mm]	45	55	70	75	90
Effective external diameter anchor	d_{nom}	[mm]	8	10	12	16	20
Partial safety factor	$\gamma_{Mc}^{1)}$	[-]	1.5 ²⁾				

¹⁾ In absence of other national regulations.

²⁾ The partial safety factor $\gamma_2=1.0$ is included.

Table 8 : Displacements under shear loads

Type of anchor / Size			AJE M8	AJE M10	AJE M12	AJE M16	AJE M20
Service shear load in cracked and uncracked concrete C20/25	V	[kN]	5.7	9.5	16.7	28.6	45.2
Displacements	δ_{V0}	[mm]	2.0	2.0	3.0	4.0	6.0
	$\delta_{V\infty}$	[mm]	3.0	4.0	6.0	8.0	10.0

Tecfi wedge Anchor AJE

Design Method A,
Characteristic values of resistance and
displacement under shear loads

Annex 6

Table 9 : Characteristic values to tension loads under fire exposure in cracked and uncracked concrete C20/25 to C50/60 for M8 – M10 – M12 – M16 – M20

Duration of fire resistance = 30min, anchor type AJE			M8	M10	M12	M16	M20
Steel failure							
Characteristic Resistance	$N_{Rk,s,fi,30}$	[kN]	0.2	0.51	1.08	1.8	3.3
Pull-out failure							
Characteristic Resistance in concrete C20/25 to C50/60	$N_{Rk,p,fi,30}$	[kN]	1.50	2.25	4.00	6.25	7.50
Concrete cone failure							
Characteristic Resistance in concrete C20/25 to C50/60	$N_{Rk,c,fi,30}^0$	[kN]	2.45	4.04	7.38	11.8	17.8
Duration of fire resistance = 60min, anchor type AJE			M8	M10	M12	M16	M20
Steel failure							
Characteristic Resistance	$N_{Rk,s,fi,60}$	[kN]	0.18	0.45	0.81	1.32	2.49
Pull-out failure							
Characteristic Resistance in concrete C20/25 to C50/60	$N_{Rk,p,fi,60}$	[kN]	1.50	2.25	4.00	6.25	7.50
Concrete cone failure							
Characteristic Resistance in concrete C20/25 to C50/60	$N_{Rk,c,fi,60}^0$	[kN]	2.45	4.04	7.38	11.8	17.8
Duration of fire resistance = 90min, anchor type AJE			M8	M10	M12	M16	M20
Steel failure							
Characteristic Resistance	$N_{Rk,s,fi,90}$	[kN]	0.1	0.34	0.70	1.1	2.2
Pull-out failure							
Characteristic Resistance in concrete C20/25 to C50/60	$N_{Rk,p,fi,90}$	[kN]	1.50	2.25	4.00	6.25	7.50
Concrete cone failure							
Characteristic Resistance in concrete C20/25 to C50/60	$N_{Rk,c,fi,90}^0$	[kN]	2.45	4.04	7.38	11.8	17.8
Duration of fire resistance = 120min, anchor type AJE			M8	M10	M12	M16	M20
Steel failure							
Characteristic Resistance	$N_{Rk,s,fi,120}$	[kN]	0.1	0.27	0.54	0.88	1.66
Pull-out failure							
Characteristic Resistance in concrete C20/25 to C50/60	$N_{Rk,p,fi,120}$	[kN]	1.20	1.80	3.20	5.0	6.0
Concrete cone failure							
Characteristic Resistance in concrete C20/25 to C50/60	$N_{Rk,c,fi,120}^0$	[kN]	1.96	3.23	5.90	9.5	14.2
Spacing	$S_{cr,N}$	[mm]	4 x h_{ef}				
	S_{min}		80	80	90	130	200
Edge distance	$C_{cr,N}$		2 x h_{ef}				
	C_{min}		$C_{min} = 2xh_{ef}$; If fire attack comes from more than one side, the edge distance of the anchor has to be $\geq 300\text{mm}$ or $\geq 2 x h_{ef}$				

In absence of other national regulations the partial safety factor for resistance under fire exposure $\gamma_{m,fi} = 1.0$ is recommended

Tecfi wedge Anchor AJE

Characteristic values of tension load under fire exposure

Annex 7

Table 10 : Characteristic values to shear loads under fire exposure in cracked and uncracked concrete C20/25 to C50/60 for M8 – M10 – M12 – M16 – M20

Duration of fire resistance = 30min, anchor type AJE			M8	M10	M12	M16	M20
Shear load without lever arm							
Characteristic resistance	$V_{Rk,s,fi,30}$	[kN]	0.2	0.51	1.08	1.8	3.3
Shear load with lever arm							
Characteristic bending resistance	$M_{Rk,s,fi,30}^0$	[Nm]	0.4	1.1	2.6	6.7	13.0
Duration of fire resistance = 60min, anchor type AJE			M8	M10	M12	M16	M20
Shear load without lever arm							
Characteristic resistance	$V_{Rk,s,fi,60}$	[kN]	0.18	0.45	0.81	1.32	2.49
Shear load with lever arm							
Characteristic bending resistance	$M_{Rk,s,fi,60}^0$	[Nm]	0.3	1.0	2.0	5.0	9.7
Duration of fire resistance = 90min, anchor type AJE			M8	M10	M12	M16	M20
Shear load without lever arm							
Characteristic resistance	$V_{Rk,s,fi,90}$	[kN]	0.1	0.34	0.70	1.1	2.2
Shear load with lever arm							
Characteristic bending resistance	$M_{Rk,s,fi,90}^0$	[Nm]	0.3	0.7	1.7	4.3	8.4
Duration of fire resistance = 120min, anchor type AJE			M8	M10	M12	M16	M20
Shear load without lever arm							
Characteristic resistance	$V_{Rk,s,fi,120}$	[kN]	0.1	0.27	0.54	0.88	1.66
Shear load with lever arm							
Characteristic bending resistance	$M_{Rk,s,fi,120}^0$	[Nm]	0.2	0.6	1.3	3.3	6.5
Concrete pryout failure							
The characteristic resistance $V_{rk,cp,fi,Ri}$ in concrete C20/25 to C50/60 is determined by: $V_{Rk,c,fi(90)} = k \times N_{Rk,c,fi(90)} (\leq R90)$ and $V_{Rk,c,fi(120)} = k \times N_{Rk,c,fi(120)}$ (up to R120)							
Concrete edge failure							
The characteristic resistance $V_{rk,cp,fi,Ri}$ in concrete C20/25 to C50/60 is determined by $V_{Rk,c,fi(90)}^0 = 0,25 \times V_{Rk,c}^0$ (R30, R60, R90) and $V_{Rk,c,fi(120)}^0 = 0,20 \times V_{Rk,c}^0$ (R120) with $V_{Rk,c}^0$ as an initial value of the characteristic resistance of a single anchor in cracked concrete C20/25							

In absence of other national regulations the partial safety factor for resistance under fire exposure $\gamma_{m,fi} = 1.0$ is recommended

Tecfi wedge Anchor AJE

Characteristic values of shear load under fire exposure

Annex 8