



European Technical Approval ETA-12/0003

English translation prepared by DIBt - Original version in German language

Handelsbezeichnung <i>Trade name</i>	Sormat Universal-Rahmendübel S-UF, S-UP und S-FP <i>Sormat Universal Facade Plugs S-UF, S-UP and S-FP</i>
Zulassungsinhaber <i>Holder of approval</i>	Sormat Oy Harjutie 5 21290 RUSKO FINNLAND
Zulassungsgegenstand und Verwendungszweck <i>Generic type and use of construction product</i>	Kunststoffdübel als Mehrfachbefestigung von nichttragenden Systemen zur Verankerung im Beton und Mauerwerk <i>Plastic anchors for multiple use in concrete and masonry for non- structural applications</i>
Geltungsdauer: <i>Validity:</i>	vom <i>from</i> bis <i>to</i> 13 January 2012 13 January 2017
Herstellwerk <i>Manufacturing plant</i>	Sormat Werk 1 / Sormat Plant 1

Diese Zulassung umfasst
This Approval contains

21 Seiten einschließlich 9 Anhänge
21 pages including 9 annexes

I LEGAL BASES AND GENERAL CONDITIONS

- 1 This European technical approval is issued by Deutsches Institut für Bautechnik in accordance with:
 - Council Directive 89/106/EEC of 21 December 1988 on the approximation of laws, regulations and administrative provisions of Member States relating to construction products¹, modified by Council Directive 93/68/EEC² and Regulation (EC) N° 1882/2003 of the European Parliament and of the Council³;
 - Gesetz über das In-Verkehr-Bringen von und den freien Warenverkehr mit Bauprodukten zur Umsetzung der Richtlinie 89/106/EWG des Rates vom 21. Dezember 1988 zur Angleichung der Rechts- und Verwaltungsvorschriften der Mitgliedstaaten über Bauprodukte und anderer Rechtsakte der Europäischen Gemeinschaften (Bauproduktengesetz - BauPG) vom 28. April 1998⁴, as amended by law of 31 October 2006⁵;
 - Common Procedural Rules for Requesting, Preparing and the Granting of European technical approvals set out in the Annex to Commission Decision 94/23/EC⁶;
 - Guideline for European technical approval of "Plastic Anchors for Multiple Use in Concrete and Masonry for Non-structural Applications – Part 1: General", ETAG 020-01.
- 2 Deutsches Institut für Bautechnik is authorized to check whether the provisions of this European technical approval are met. Checking may take place in the manufacturing plant. Nevertheless, the responsibility for the conformity of the products to the European technical approval and for their fitness for the intended use remains with the holder of the European technical approval.
- 3 This European technical approval is not to be transferred to manufacturers or agents of manufacturers other than those indicated on page 1, or manufacturing plants other than those indicated on page 1 of this European technical approval.
- 4 This European technical approval may be withdrawn by Deutsches Institut für Bautechnik, in particular pursuant to information by the Commission according to Article 5(1) of Council Directive 89/106/EEC.
- 5 Reproduction of this European technical approval including transmission by electronic means shall be in full. However, partial reproduction can be made with the written consent of Deutsches Institut für Bautechnik. In this case partial reproduction has to be designated as such. Texts and drawings of advertising brochures shall not contradict or misuse the European technical approval.
- 6 The European technical approval is issued by the approval body in its official language. This version corresponds fully to the version circulated within EOTA. Translations into other languages have to be designated as such.

¹ Official Journal of the European Communities L 40, 11 February 1989, p. 12
² Official Journal of the European Communities L 220, 30 August 1993, p. 1
³ Official Journal of the European Union L 284, 31 October 2003, p. 25
⁴ *Bundesgesetzblatt Teil I* 1998, p. 812
⁵ *Bundesgesetzblatt Teil I* 2006, p. 2407, 2416
⁶ Official Journal of the European Communities L 17, 20 January 1994, p. 34

II SPECIFIC CONDITIONS OF THE EUROPEAN TECHNICAL APPROVAL

1 Definition of product/ products and intended use

1.1 Definition of the construction product

The Sormat Universal Facade Plugs S-UF, S-UP and S-FP are plastic anchors consisting of a plastic sleeve made of polyamide and an accompanying specific screw of electro galvanised steel, mechanical galvanized steel, stainless steel (A2) or of stainless steel (A4).

The plastic sleeve is expanded by screwing in the specific screw which presses the sleeve against the wall of the drilled hole.

The installed anchor is shown in Annex 1.

1.2 Intended use

The anchor is intended to be used for anchorages for which requirements for safety in use in the sense of the Essential Requirement 4 of Council Directive 89/106/EEC shall be fulfilled and failure of the fixture represents an immediate risk to human life.

The anchor is to be used only for multiple fixing for non-structural applications.

The anchor is to be used for in-place and pre-positioned anchorages.

The base material may consist of use category a, b and c as given in the following Table:

Use category	Anchor type	Remarks
a	Sormat S-UF 10 Sormat S-UP 10 Sormat S-FP 10	<ul style="list-style-type: none"> Reinforced or unreinforced normal weight concrete Strength class C12/15 at minimum and C50/60 at maximum according to EN 206-1:2000-12 Cracked and non-cracked concrete The anchors may also be used with requirements related to resistance to fire according 4.2.2.
b	Sormat S-UF 10 Sormat S-UP 10 Sormat S-FP 10	<ul style="list-style-type: none"> Masonry walls according to Annex 7 Mortar strength class \geq M 2,5 according to EN 998-2:2003
c	Sormat S-UF 10 Sormat S-UP 10 Sormat S-FP 10	<ul style="list-style-type: none"> Masonry walls according to Annex 7 Mortar strength class \geq M 2,5 according to EN 998-2:2003

Specific screws of electro galvanized steel, mechanical galvanized steel or stainless steel (A2):

The specific screws made of electro galvanized steel, mechanical galvanized steel or stainless steel (A2) may only be used in structures subject to dry internal conditions.

For in-place anchorages these screws according Annex 2 and 3 may also be used in structures subject to external atmospheric exposure, if the area of the head of the screw is protected against moisture and driving rain after mounting of the fixing unit in this way, that intrusion of moisture into the anchor shaft is prevented. Therefore there shall be an external cladding or a ventilated rainscreen mounted in front of the head of the screw and the head of the screw itself shall be coated with a soft plastic, permanently elastic bitumen-oil-combination coating (e. g. undercoating or body cavity protection for cars).

Specific screws of stainless steel (A4):

The specific screw made of stainless steel (A4) may be used in structures subject to dry internal conditions and also in structures subject to external atmospheric exposure (including industrial and marine environment), or exposure in permanently damp internal conditions, if no particular aggressive conditions exist. Such particular aggressive conditions are e. g. permanent, alternating immersion in seawater or the splash zone of seawater, chloride atmosphere of indoor swimming pools or atmosphere with extreme chemical pollution (e. g. in desulphurization plants or road tunnels where de-icing materials are used).

The anchor may be used in the following temperature range:

Temperature range a):	-40 °C to +40 °C	(max long term temperature +24 °C and max short term temperature +40 °C)
Temperature range b):	-40 °C to +80 °C	(max long term temperature +50 °C and max short term temperature +80 °C)

The provisions made in this European Technical Approval are based on an assumed working life of the anchor of 50 years. The indications given on the working life cannot be interpreted as a guarantee given by the producer, but are to be regarded only as a means for choosing the right products in relation to the expected economically reasonable working life of the works.

2 Characteristics of the product and methods of verification

2.1 Characteristics of the product

The anchor corresponds to the drawings and information given in Annex 2 and 3. The characteristic material values, dimensions and tolerances of the anchor not given in these Annexes shall correspond to the respective values laid down in the technical documentation⁷ of this European Technical Approval.

The characteristic values for the design of the anchorages are given in Annex 4 to 9.

Each anchor is to be marked with the identifying mark and the type according to Annex 2. Each of the five anchor lengths has its own colour according to Annex 3, Table 2.

The minimum embedment depths shall be marked.

The anchor shall only be packaged and supplied as a complete unit.

⁷ The technical documentation of this European Technical Approval is deposited at the Deutsches Institut für Bautechnik and, as far as relevant for the tasks of the approved bodies involved in the attestation of conformity procedure, is handed over to the approved bodies.

2.2 Methods of verification

The assessment of the fitness of the anchor for the intended use in relation to the requirements for safety in use in the sense of the Essential Requirement 4 has been made in compliance with the Guideline for European Technical Approval of "Plastic Anchors for Multiple Use in Concrete and Masonry for Non-structural Applications", ETAG 020,

- Part 1: "General",
- Part 2: "Plastic Anchors for Use in Normal Weight Concrete",
- Part 3: "Plastic Anchors for Use in Solid Masonry Materials" and
- Part 4: "Plastic Anchors for Use in Hollow or Perforated Masonry",

based on the use categories a, b and c.

In addition to the specific clauses relating to dangerous substances contained in this European Technical Approval, there may be other requirements applicable to the products falling within its scope (e. g. transposed European legislation and national laws, regulations and administrative provisions). In order to meet the provisions of the Construction Products Directive, these requirements need also to be complied with, when and where they apply.

3 Evaluation and attestation of conformity and CE marking

3.1 System of attestation of conformity

According to the decision 97/463/EG of the European Commission⁸ the system 2(ii) (referred to as system 2+) of attestation of conformity applies.

This system of attestation of conformity is defined as follows.

System 2+: Declaration of conformity of the product by the manufacturer on the basis of:

- (a) Tasks for the manufacturer:
 - (1) initial type-testing of the product;
 - (2) factory production control;
 - (3) testing of samples taken at the factory in accordance with a prescribed control plan.
- (b) Tasks for the approved body:
 - (4) certification of factory production control on the basis of:
 - initial inspection of factory and of factory production control;
 - continuous surveillance, assessment and approval of factory production control.

3.2 Responsibilities

3.2.1 Tasks of the manufacturer

3.2.1.1 Factory production control

The manufacturer shall exercise permanent internal control of production. All the elements, requirements and provisions adopted by the manufacturer shall be documented in a systematic manner in the form of written policies and procedures, including records of results performed. This production control system shall insure that the product is in conformity with this European Technical Approval.

The manufacturer may only use raw materials stated in the technical documentation of this European Technical Approval.

⁸ Official Journal of the European Communities L 198 of 25.07.1997.

The factory production control shall be in accordance with the control plan which is part of the technical documentation of this European Technical Approval. The control plan is laid down in the context of the factory production control system operated by the manufacturer and deposited at Deutsches Institut für Bautechnik.⁹

The results of factory production control shall be recorded and evaluated in accordance with the provisions of the control plan.

3.2.1.2 Other tasks of manufacturer

The manufacturer shall, on the basis of a contract, involve a body which is approved for the tasks referred to in section 3.1 in the field of anchors in order to undertake the actions laid down in section 3.2.2. For this purpose, the control plan referred to in sections 3.2.1.1 and 3.2.2 shall be handed over by the manufacturer to the approved body involved.

The manufacturer shall make a declaration of conformity, stating that the construction product is in conformity with the provisions of this European Technical Approval.

3.2.2 Tasks of approved bodies

The approved body shall perform the

- initial inspection of factory and of factory production control,
- continuous surveillance, assessment and approval of factory production control,

in accordance with the provisions laid down in the control plan.

The approved body shall retain the essential points of its actions referred to above and state the results obtained and conclusions drawn in a written report.

The approved certification body involved by the manufacturer shall issue an EC certificate of conformity of the factory production control stating the conformity with the factory production control of this European Technical Approval.

In cases where the provisions of the European Technical Approval and its control plan are no longer fulfilled the certification body shall withdraw the certificate of conformity and inform Deutsches Institut für Bautechnik without delay.

3.3 CE marking

The CE marking shall be affixed on each packaging of the anchor. The letters "CE" shall be followed by the identification number of the approved certification body, where relevant, and be accompanied by the following additional information:

- the name and address of the producer (legal entity responsible for the manufacturer),
- the last two digits of the year in which the CE marking was affixed,
- the number of the EC certificate for the factory production control,
- the number of the European Technical Approval,
- the number of the guideline for European Technical Approval,
- use category a, b and c.

⁹

The control plan is a confidential part of the documentation of the European Technical Approval, but not published together with the ETA and only handed over to the approved body involved in the procedure of attestation of conformity. See section 3.2.2.

4 Assumptions under which the fitness of the product for the intended use was favourably assessed

4.1 Manufacturing

The European Technical Approval is issued for the product on the basis of agreed data/information, deposited with Deutsches Institut für Bautechnik, which identifies the product that has been assessed and judged. Changes to the product or production process, which could result in this deposited data/information being incorrect, should be notified to Deutsches Institut für Bautechnik before the changes are introduced. Deutsches Institut für Bautechnik will decide whether or not such changes affect the ETA and consequently the validity of the CE marking on the basis of the ETA and if so whether further assessment or alterations to the ETA shall be necessary.

4.2 Design of anchorages

4.2.1 General

Fitness for the intended use of the anchor is given under the following conditions:

- The design of anchorages is carried out in compliance with ETAG 020, Guideline for European Technical Approval of "Plastic Anchors for Multiple Use in Concrete and Masonry for Non-structural Applications", Annex C under the responsibility of an engineer experienced in anchorages.
- Verifiable calculation notes and drawings shall be prepared taking account of the loads to be anchored, the nature and strength of the base materials and the dimensions of the anchorage members as well as of the relevant tolerances.
- The anchor is to be used only for multiple fixing for non-structural applications.

Therefore the design of the fixture may specify the number n_1 of fixing points to fasten the fixture and the number n_2 of anchors per fixing point. Furthermore the design value of actions N_{Sd} on a fixing point to a value $\leq n_3$ (kN) is specified up to which the strength and stiffness of the fixture are fulfilled and the load transfer in the case of excessive slip or failure of one anchor need not be taken into account in the design of the fixture.

The following default values for n_1 , n_2 and n_3 may be taken:

$$\begin{array}{l} n_1 \geq 4; \quad n_2 \geq 1 \quad \text{and} \quad n_3 \leq 4,5 \text{ kN} \quad \text{or} \\ n_1 \geq 3; \quad n_2 \geq 1 \quad \text{and} \quad n_3 \leq 3,0 \text{ kN}. \end{array}$$

- Shear loads acting on an anchor may be assumed to act without lever arm if both of the following conditions are fulfilled:
 - The fixture shall be made of metal and in the area of the anchorage be fixed directly to the base material either without an intermediate layer or with a levelling layer of mortar with a thickness ≤ 3 mm.
 - The fixture shall be in contact with the anchor over its entire thickness. (Therefore the diameter of clearance hole in the fixture d_f has to be equal or smaller than the value given in Annex 4, Table 3.)

If these two conditions are not fulfilled the lever arm is calculated according to ETAG 020, Annex C. The characteristic bending moment is given in Annex 4, Table 4.

4.2.2 Resistance in concrete (use category "a")

The characteristic values of resistance of the anchor for use in concrete are given in Annex 4 and 5. The design method is valid for cracked and non-cracked concrete.

According to the Technical Report TR 020 "Evaluation of anchorages in concrete concerning resistance to fire" it can be assumed that for fastening of facade systems the load bearing behaviour of the Sormat Universal Facade Plugs S-UF, S-UP and S-FP has a sufficient resistance to fire at least 90 minutes (R90) if the admissible load $[F_{Rk} / (\gamma_M \cdot \gamma_F)]$ is $\leq 0,8$ kN (no permanent centric tension load).

4.2.3 Resistance in solid masonry (use category "b")

The characteristic values of resistance of the anchor for use in solid masonry are given in Annex 4, Table 4 and Annex 7, Table 9. These values are independent of the load direction (tension, shear or combined tension and shear) and the mode of failure.

The characteristic resistances given in Annex 7, Table 9 for use in solid masonry are only valid for the base material and the bricks according this table or larger brick sizes and larger compressive strength of the masonry unit.

If smaller brick sizes are present on the construction site or if the mortar strength is smaller than the required value, the characteristic resistance of the anchor may be determined by job site tests according to 4.4.

4.2.4 Resistance in hollow or perforated masonry (use category "c")

The characteristic resistances for use in hollow or perforated masonry given in Annex 4, Table 4 and Annex 7, Table 9 are only valid for the bricks and blocks according this table regarding base material, size of the units, compressive strength and configuration of the voids.

These values are independent of the load direction (tension, shear or combined tension and shear) and the mode of failure and are valid for $h_{nom} = 70$ mm only.

The influence of larger embedment depths ($h_{nom} > 70$ mm) and/or different bricks and blocks (according Annex 7, Table 9 regarding base material, size of the units, compressive strength and configuration of the voids) has to be detected by job site tests according to 4.4.

4.2.5 Specific conditions for the design method in solid masonry and hollow or perforated masonry

The mortar strength class of the masonry has to be M 2,5 according to EN 998-2:2003 at minimum.

The characteristic resistance F_{Rk} for a single plastic anchor may also be taken for a group of two or four plastic anchors with a spacing equal or larger than the minimum spacing s_{min} .

The distance between single plastic anchors or a group of anchors should be $a \geq 250$ mm.

If the vertical joints of the wall are designed not to be filled with mortar then the design resistance N_{Rd} has to be limited to 2,0 kN to ensure that a pull-out of one brick out of the wall will be prevented. This limitation can be omitted if interlocking units are used for the wall or when the joints are designed to be filled with mortar.

If the joints of the masonry are not visible the characteristic resistance F_{Rk} has to be reduced with the factor $\alpha_j = 0,5$.

If the joints of the masonry are visible (e.g. unplastered wall) following has to be taken into account:

- The characteristic resistance F_{Rk} may be used only, if the wall is designed such that the joints are to be filled with mortar.
- If the wall is designed such that the joints are not to be filled with mortar then the characteristic resistance F_{Rk} may be used only, if the minimum edge distance c_{min} to the vertical joints is observed. If this minimum edge distance c_{min} can not be observed then the characteristic resistance F_{Rk} has to be reduced with the factor $\alpha_j = 0,5$.

4.2.6 Characteristic values, spacing and dimensions of anchorage member

The minimum spacing and dimensions of anchorage member according to Annex 6, Table 8 and Annex 8, Table 11 shall be observed depending on the base material.

4.2.7 Displacement behaviour

The displacements under tension and shear loading in concrete and masonry are given in Annex 6, Table 7 and Annex 7, Table 10.

4.3 Installation of anchor

The fitness for use of the anchor can only be assumed if the following conditions of installation are met:

- Anchor installation carried out by appropriately qualified personnel under the supervision of the person responsible for technical matters on site.
- Use of the anchor only as supplied by the manufacturer without exchanging any component of the anchor.
- Anchor installation in accordance with the manufacturer's specifications and drawings using the tools indicated in this European Technical Approval.
- Checks before placing the anchor, to ensure that the characteristic values of the base material in which the anchor is to be placed, is identical with the values, which the characteristic loads apply for.
- Observation of the drill method according Annex 7, Table 9 (Drill holes in hollow or perforated masonry may only be drilled using the rotary drill. Other drilling methods may also be used if job-site tests according to 4.4 evaluate the influence of hammer or impact drilling.).
- Placing drill holes without damaging the reinforcement.
- Holes to be cleaned of drilling dust.
- In case of aborted hole: New drilling at a minimum distance away of twice the depth of the aborted hole or smaller distance if the aborted drill hole is filled with high strength mortar.

- The anchor is to be used for in-place and pre-positioned anchorages.
 - In-place anchorages (anchor types S-UF and S-UP): The plastic sleeve is inserted through the fixture by slight hammer blows and the special screw is screwed in until the head of the screw touches the sleeve. The anchor is correctly mounted, if there is no turn-through of the plastic sleeve in the drill hole and if slightly move on turning of the screw is impossible after the complete turn-in of the screw.
 - Pre-positioned anchorages (anchor type S-FP): Depending on the maximum thickness of fixture ($\max t_{fix}$) a defined combination of plastic sleeve and special screw is given in Annex 3, Table 1b for the anchor type S-FP for pre-positioned anchorages. The plastic sleeve is inserted directly into the base material by slight hammer blows and the special screw is screwed in through the fixture until the head of the screw touches the fixture. The anchor is correctly mounted, if there is no turn-through of the plastic sleeve in the drill hole and if slightly move on turning of the screw is impossible after the complete turn-in of the screw. For hollow or perforated masonry the influence of $h_{nom} > 70$ mm has to be determined by job site tests according 4.2.4 and 4.4.
- Temperature during installation of the anchor ≥ -20 °C (plastic sleeve and base material).

4.4 Job site tests according to ETAG 020, Annex B

4.4.1 General

In the absence of national requirements the characteristic resistance of the plastic anchor may be determined by job site tests, if the plastic anchor has already characteristic values given in Annex 5 and 7 for the same base material as it is present on the construction works.

Furthermore job site tests for use in different concrete, solid masonry and hollow or perforated masonry are possible only if the plastic anchor has already characteristic values given in Annex 5 and 7 for use in the equivalent base material.

Job site tests are also possible, if another drill method is been used as it is given in Annex 7, Table 9.

The characteristic resistance to be applied to a plastic anchor should be determined by means of at least 15 pull-out tests carried out on the construction work with a centric tension load acting on the plastic anchor. These tests may also performed in a laboratory under equivalent conditions as used on construction work.

Execution and evaluation of the tests as well as issue of the test report and determination of the characteristic resistance should be supervised by the person responsible for execution of works on site and be carried out by a competent person.

Number and position of the plastic anchors to be tested should be adapted to the relevant special conditions of the construction work in question and, for example, in the case of blind and larger areas be increased such that a reliable information about the characteristic resistance of the plastic anchor embedded in the base material in question can be derived. The tests should take account of the unfavourable conditions of practical execution.

4.4.2 Assembly

The plastic anchor to be tested shall be installed (e. g. preparation of drill hole, drilling tool to be used, drill bit, type of drilling hammer or rotation, thickness of fixture) and as far as spacing and edge distances are concerned be distributed in the same way as foreseen for the intended use.

Depending on the drilling tool hard metal hammer drill bits or hard metal percussion drill bits, respectively, according to ISO 5468 should be used. New drill bits should be used for one test series or drill bits with $d_{cut,m} = 10,25$ mm $< d_{cut} \leq 10,45$ mm = $d_{cut,max}$.

4.4.3 Execution of test

The test rig used for the pull-out tests shall provide a continuous slow increase of the load, controlled by a calibrated load cell. The load shall apply perpendicular to the surface of the base material and shall be transmitted to the anchor via a hinge. The reaction forces shall be transmitted into the base material such that possible breakout of the masonry is not restricted. This condition is considered as fulfilled, if the support reaction forces are transmitted either in adjacent masonry units or at a distance of at least 150 mm from the plastic anchors. The load shall be increased continuously in a way that the ultimate load is reached after about 1 minute. The load is measured when the ultimate load (N_1) is achieved.

If no pull-out failure occurs, other test methods are needed, e.g. proof-loading.

4.4.4 Test report

The test report shall include all information necessary to assess the resistance of the tested anchor. It shall be given to the person responsible for the design of the fastening and shall be included in the construction dossier.

The minimum data required are:

- Name of product
- Construction site, owner of building; date and location of the tests, air temperature
- Date and place of tests
- Test rig
- Type of structure to be fixed
- Base material (e.g. type of brick, strength class, all dimensions of bricks, mortar group if possible); visual assessment of masonry (flush joints, joint clearance, regularity)
- Plastic anchor and special screw
- value of the cutting diameter of hard metal hammer-drill bits, measured before and after drilling if no new drill bits are used
- Results of tests including the indication of value N_1 ; mode of failure
- Tests carried out or supervised by ...; signature

4.4.5 Evaluation of test results

The characteristic resistance F_{Rk1} is derived from the measured values N_1 as follows

$$F_{Rk1} = 0,5 \cdot N_1$$

The characteristic resistance F_{Rk1} has to be equal or smaller than the characteristic resistance F_{Rk} which is given in the ETA for the equivalent base material

$$N_1 = \text{the mean value of the five smallest measured values at ultimate load}$$

In absence of national regulations the partial safety factors for the resistance of the plastic anchor may be taken as $\gamma_{Mc} = 1,8$ for use in concrete and $\gamma_{Mm} = 2,5$ for use in masonry.

5 Indications to the manufacturer

5.1 Responsibility of the manufacturer

It is in the responsibility of the manufacturer to ensure that the information on the specific conditions according to 1 and 2 including Annexes referred to 4 is given to those who are concerned. This information may be made by reproduction of the respective parts of the European Technical Approval. In addition, all installation data shall be shown clearly on the packaging and/or on an enclosed instruction sheet, preferably using illustrations.

The minimum data required are:

- base material for the intended use,
- ambient temperature of the base material during installation of the anchor,
- drill bit diameter (d_{cut}),
- overall anchor embedment depth in the base material (h_{nom}),
- minimum hole depth (h_0),
- information on the installation procedure,
- identification of the manufacturing batch.

All data shall be presented in a clear and explicit form.

5.2 Packaging, transport and storage

The anchor shall only be packaged and supplied as a complete unit.

The anchor shall be stored under normal climatic conditions in its original light-proof packaging. Before installation, it shall not be extremely dried nor frozen.

Georg Feistel
Head of Department

beglaubigt:
Scheller

Sormat Universal Façade Plug

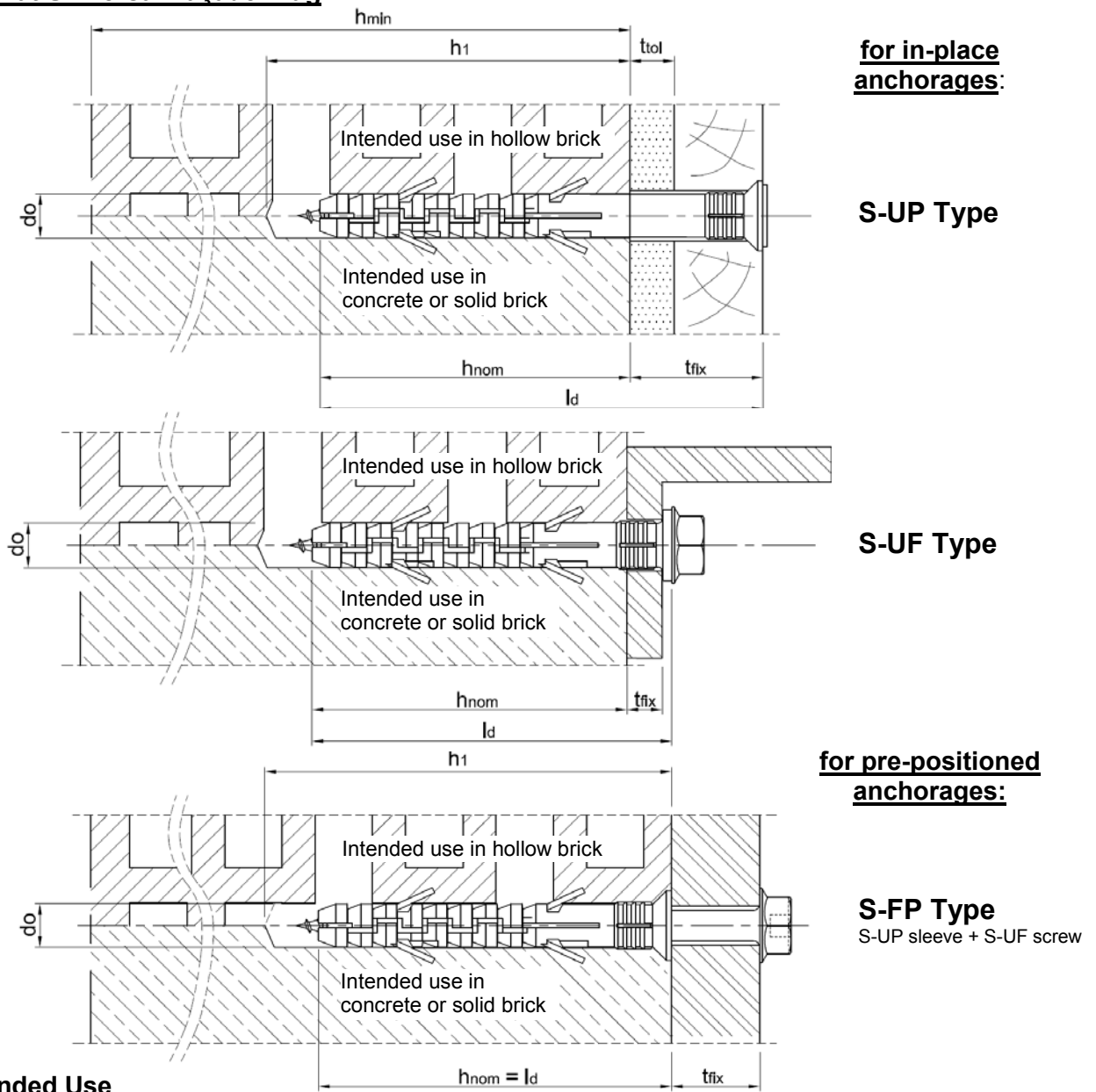

Fixing in cracked or non-cracked concrete, solid, hollow or perforated masonry

Legend

- h_{nom} = overall plastic anchor embedment depth in the base material
- h_1 = depth of drilled hole to deepest point
- h_{min} = minimum thickness of member
- t_{fix} = thickness of fixture including t_{tol}
- t_{tol} = thickness of layer or non-load bearing coating

Sormat Universal Façade Plugs S-UF, S-UP and S-FP

Intended use

Annex 1

Anchor sleeves:

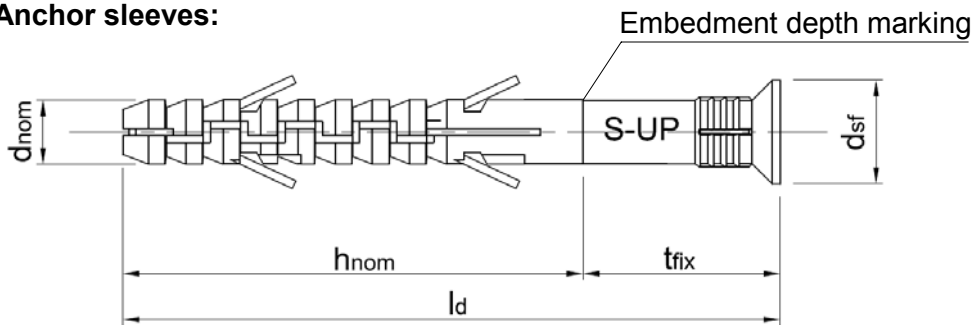

Sleeve marking

Brand: S
Type: UP
UF

Sleeve colors

Cream: L = 80
Beige: L = 100
Grey: L = 115
Orange: L = 135
Blue: L ≥ 160

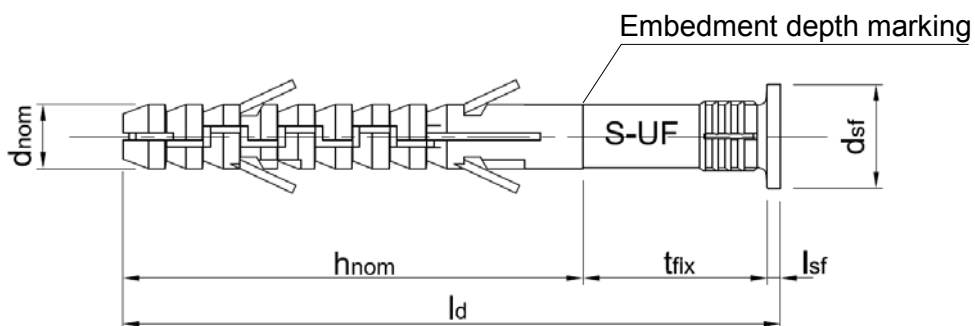

Special screws:

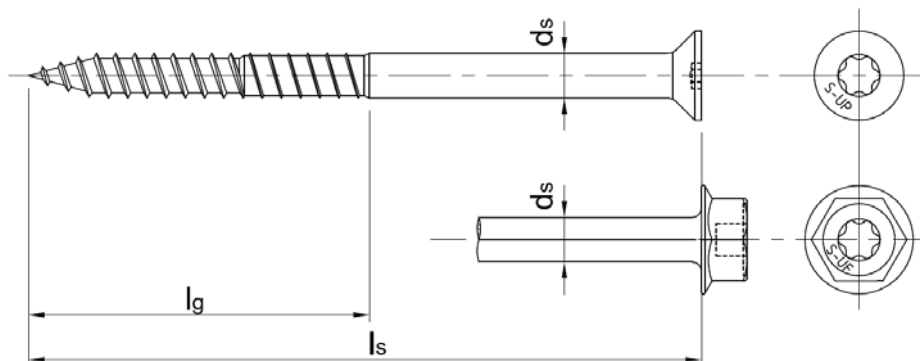

Screw marking

Brand: S
Type: UP
UF
Category¹⁾: A2
A4

¹⁾: where applicable

Type S-FP:

The anchor type **S-FP** for pre-positioned anchorages (compare Annex 1) is a combination of the S-UP sleeves and the S-UF screws. Details are given in Annex 3, Table 1b and Annex 4, Table 3.

Sormat Universal Facade Plugs S-UF, S-UP and S-FP

Anchor types and special screws

Annex 2

Table 1a: Dimensions S-UP and S-UF (for in-place anchorages)

Anchor type	Anchor sleeve						Special screw		
	h_{nom} [mm]	d_{nom} [mm]	t_{fix} [mm]	l_d [mm]	l_{sf} [mm]	d_{sf} [mm]	d_s [mm]	l_g [mm]	l_s ¹⁾ [mm]
S-UP 10	70	10	≥ 1	80-360	-	14	7	75	85-365
S-UF 10	70	10	≥ 1	80-360	2	16	7	75	85-365

¹⁾ To ensure that the screw penetrates the anchor sleeve, l_s must be $l_d + 5$ mm

Table 1b: Dimensions S-FP (for pre-positioned anchorages)

Anchor type S-FP $d_0 \times l_d/t_{fix}$	Anchor sleeve						Special screw		
	h_{nom} ¹⁾ [mm]	d_{nom} [mm]	max t_{fix} [mm]	l_d [mm]	l_{sf} [mm]	d_{sf} [mm]	d_s [mm]	l_g [mm]	l_s ²⁾ [mm]
S-FP 10x80/20	80	10	20	80	-	14	7	75	105
S-FP 10x80/35	80	10	35	80	-	14	7	75	120
S-FP 10x80/55	80	10	55	80	-	14	7	75	140
S-FP 10x80/80	80	10	80	80	-	14	7	75	165
S-FP 10x100/15	100	10	15	100	-	14	7	75	120
S-FP 10x100/35	100	10	35	100	-	14	7	75	140
S-FP 10x100/60	100	10	60	100	-	14	7	75	165
S-FP 10x115/20	115	10	20	115	-	14	7	75	140
S-FP 10x115/45	115	10	45	115	-	14	7	75	165
S-FP 10x135/25	135	10	25	135	-	14	7	75	165

¹⁾ For hollow and perforated masonry, the influence of $h_{nom} > 70$ mm has to be determined by job site tests according 4.2.4 and 4.4.

²⁾ To ensure that the screw penetrates the anchor sleeve, l_s must be $l_d + t_{fix} + 5$ mm

Table 2: Materials

Part	Designation	Material	Color	l_d [mm]
1	Anchor sleeve	Polyamide	Cream	80
			Beige	100
			Grey	115
			Orange	135
			Blue	≥ 160
2	Special screw	Steel $f_{yk} \geq 640$ N/mm ² , $f_{uk} \geq 800$ N/mm ²	Electro galvanized ≥ 5 μ m acc. EN ISO 4042	
			Mechanical galvanized ≥ 25 μ m acc. EN ISO 12683	
		Stainless steel (A2 and A4) $f_{yk} \geq 480$ N/mm ² , $f_{uk} \geq 600$ N/mm ²	According to EN 10088	

Sormat Universal Facade Plugs S-UF, S-UP and S-FP

Dimensions and materials

Annex 3

Table 3: Installation parameters

Anchor type			S-UP/UF/FP 10
Drill hole diameter	$d_o =$	[mm]	10
Cutting diameter of drill bit	$d_{cut} \leq$	[mm]	10,45
Depth of drilled hole to the deepest point ^{1) 2)}	$h_1 \geq$	[mm]	80
Overall plastic anchor embedment depth in the base material ^{1) 3)}	$h_{nom} \geq$	[mm]	70
Diameter of clearance hole in the fixture	In-place anchorages	$d_f =$	10,5
	Pre-positioned anchorages	$d_f =$	7,0
Temperature for installation	$\vartheta =$	[°C]	-20 to +40
Temperature for use	$\vartheta =$	[°C]	-40 to +80

¹⁾ See Annex 1

²⁾ For pre-positioned anchorages the depth of drilled hole to the deepest point has to be $h_1 \geq l_s + 5 \text{ mm} - t_{fix}$.

³⁾ For hollow and perforated masonry, the influence of $h_{nom} > 70 \text{ mm}$ has to be determined by job site tests according 4.2.4 and 4.4 (compare Annex 3, Table 1b).

Table 4: Characteristic bending resistance of the screw in concrete and masonry

			Steel, electro or mechanical galvanized	Stainless steel (A2 or A4)
Characteristic bending resistance	$M_{RK,s}$	[Nm]	20,4	15,3
Partial safety factor	$\gamma_{Ms}^{1)}$	[-]	1,25	1,25

¹⁾ In absence of other national regulations

Table 5: Characteristic resistance of the screw for use in concrete (use category "a")

Failure of expansion element (special screw)			Steel, electro or mechanical galvanized	Stainless steel (A2 or A4)
Characteristic tension resistance	$N_{RK,s}$	[kN]	22,6	17,0
Partial safety factor	$\gamma_{Ms}^{1)}$	[-]	1,5	1,5
Characteristic shear resistance	$V_{RK,s}$	[kN]	11,3	8,5
Partial safety factor	$\gamma_{Ms}^{1)}$	[-]	1,25	1,25

¹⁾ In absence of other national regulations

Sormat Universal Facade Plugs S-UF, S-UP and S-FP

Installation parameters
Characteristic resistance of the special screw

Annex 4

Table 6: Characteristic resistance for use in concrete (use category “a”)

Pull-out failure (plastic sleeve)				
Temperature range	$\vartheta =$	[°C]	24 ¹⁾ / 40 ²⁾	50 ¹⁾ / 80 ²⁾
Concrete \geq C16/20				
Characteristic tension resistance	$N_{Rk,p}$	[kN]	6,5	5,5
Partial safety factor	γ_{Mc} ³⁾	[-]	1,8	
Concrete C12/15				
Characteristic tension resistance	$N_{Rk,p}$	[kN]	4,5	4,0
Partial safety factor	γ_{Mc} ³⁾	[-]	1,8	
Concrete cone failure and concrete edge failure for single anchor and anchor group				
Tension load ⁴⁾				
$N_{Rk,c} = 7,2 \cdot \sqrt{f_{ck,cube}} \cdot h_{ef}^{1,5} \cdot \frac{c}{c_{cr,N}} = N_{Rk,p} \cdot \frac{c}{c_{cr,N}}$			with: $h_{ef}^{1,5} = \frac{N_{Rk,p}}{7,2 \cdot \sqrt{f_{ck,cube}}}$ $\frac{c}{c_{cr,N}} \leq 1$	
Shear load ⁴⁾				
$V_{Rk,c} = 0,45 \cdot \sqrt{d_{nom}} \cdot (h_{nom}/d_{nom})^{0,2} \cdot \sqrt{f_{ck,cube}} \cdot c_1^{1,5} \cdot \left(\frac{c_2}{1,5c_1}\right)^{0,5} \cdot \left(\frac{h}{1,5c_1}\right)^{0,5}$			with: $\left(\frac{c_2}{1,5c_1}\right)^{0,5} \leq 1$ $\left(\frac{h}{1,5c_1}\right)^{0,5} \leq 1$	
c_1	Edge distance closest to the edge in loading direction			
c_2	Edge distance perpendicular to direction 1			
$f_{ck,cube}$	Nominal characteristic concrete compression strength (based on cubes), value for C50/60 at maximum			
Partial safety factor	γ_{Mc} ³⁾	[-]	1,8	

1) Maximum long term temperature

2) Maximum short term temperature

3) In absence of other national regulations

4) The design method according to ETAG 020, Annex C is to be used

Sormat Universal Facade Plugs S-UF, S-UP and S-FP

Characteristic resistance in concrete (use category “a”)

Annex 5

Table 7: Displacements under tension and shear loading in concrete

Concrete \geq C12/15	Tension load			Shear load		
	$F^{1)}$ [kN]	δ_{N0} [mm]	$\delta_{N\infty}$ [mm]	$F^{1)}$ [kN]	δ_{V0} [mm]	$\delta_{V\infty}$ [mm]
Temperature $\vartheta = 24/40$ °C	2,58	0,3	0,16	4,49	2,0	3,0
Temperature $\vartheta = 50/80$ °C	2,18	0,3	0,11	4,49	2,0	3,0

1) Intermediate values by linear interpolation

Table 8: Minimum thickness of member, edge distance and anchor spacing in concrete

Fixing points with a spacing $s_{cr,N} \leq 110$ mm are considered as a group with max. characteristic resistance $N_{Rk,p}$ according to Table 6. For $s_{cr,N} > 110$ mm the anchors are considered as single anchors, each with a characteristic resistance $N_{Rk,p}$ according to Table 6.

Concrete	Minimum thickness h_{min} [mm]	Characteristic edge distance $c_{cr,N}$ [mm]	Min. allowable edge distance c_{min} [mm]	Minimum allowable spacing s_{min} [mm]
\geq C16/20	120	105	120	50
C12/15	120	150	170	70

Scheme of distances and spacings in concrete

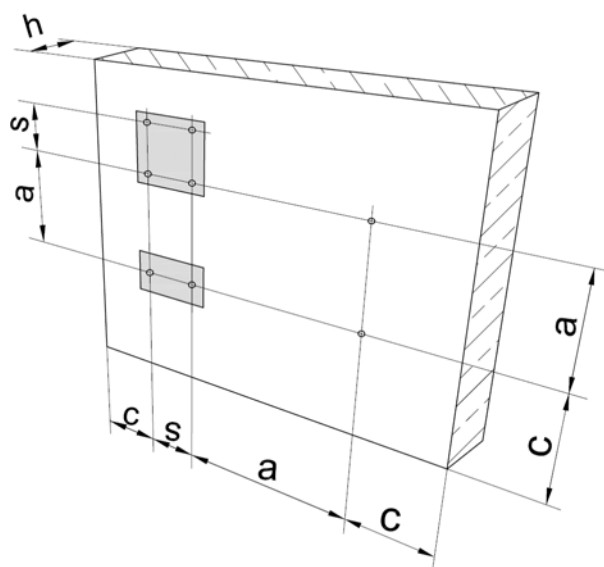

Sormat Universal Facade Plugs S-UF, S-UP and S-FP

Displacements,
Minimum thickness of member, minimum spacing and edge distances in concrete

Annex 6

**Table 9: Characteristic resistance F_{Rk} in solid and hollow or perforated masonry
(Use categories "b" and "c")**

Base material	Min. DF or min. size L x W x H [mm]	Bulk density class ρ [kg/dm ³]	Min. compress. strength f_b [N/mm ²]	Drill method [-]	Geometry [-]	Characteristic resistance F_{Rk} ¹⁾ [kN]	
						$\vartheta = 24/40$ °C ²⁾	$\vartheta = 50/80$ °C ²⁾
Clay brick Mz DIN 105 EN 771-1	NF 240x116x71	$\geq 1,8$	≥ 20	Hammer drilling	-	6,0	6,0
			≥ 12			5,0	5,0
Solid sand-lime brick KS DIN 105 EN 771-2	NF 240x115x70	$\geq 1,8$	≥ 20	Hammer drilling	-	9,0	9,0
			≥ 12			6,0	6,0
Hollow clay brick HLz DIN 105 EN 771-1	2DF 235x112x115	1,0	≥ 12	Rotary drilling only	Figure 1 Annex 9	0,9	0,75
Hollow sand-lime brick KS L DIN 105 EN 771-2	8DF 250x240x237	$\geq 1,4$	≥ 12	Rotary drilling only	Figure 2 Annex 9	2,5	2,5
Partial safety factor				γ_{Mm} ³⁾	[-]	2,5	

1) Characteristic resistance F_{Rk} for tension, shear or combined tension and shear loading.
The characteristic resistance is valid for single plastic anchor or for a group of two or four plastic anchors with spacing equal or larger than the minimum spacing s_{min} according to Annex 8, Table 11.

2) Maximum long term / short term temperature

3) In absence of other national regulations

Table 10: Displacement under tension and shear loading in masonry

Base material ¹⁾	F [kN]	Displacement			
		Tension load		Shear load	
		δ_{N0} [mm]	$\delta_{N\infty}$ [mm]	δ_{V0} [mm]	$\delta_{V\infty}$ [mm]
Clay brick Mz - NF	1,71	0,2	0,4	1,43	2,14
Solid sand-lime brick KS - NF	2,57	0,2	0,4	2,14	3,21
Hollow clay brick HLz 12-1.0	0,26	0,1	0,2	0,51	0,77
Hollow sand-lime brick KS L 12-1.4	0,71	0,2	0,4	1,43	2,14

1) Information for masonry base material see Table 9.

Sormat Universal Facade Plugs S-UF, S-UP and S-FP

Characteristic resistance and displacements
In solid and hollow masonry (use category "b" and "c")

Annex 7

Table 11: Minimum thickness of member, edge distance and anchor spacing in masonry

Base material ¹⁾	Minimum thickness of member h_{min} [mm]	Minimum allowable edge distance c_{min} [mm]	Minimum allowable spacing		
			Single anchor a_{min} [mm]	Anchor group	
				Perpendicular to free edge $s_{1,min}$ [mm]	Parallel to free edge $s_{2,min}$ [mm]
Clay brick Mz - NF	240	250	250	500	1000
Solid sand-lime brick KS - NF	240	200	250	80	80
Hollow clay brick HLz 12-1.0	240	100	250	80	80
Hollow sand-lime brick KS L 12-1.4	240	100	250	80	80

¹⁾ Information for masonry base material: see Annex 7, Table 9.

Scheme of distances and spacing in masonry

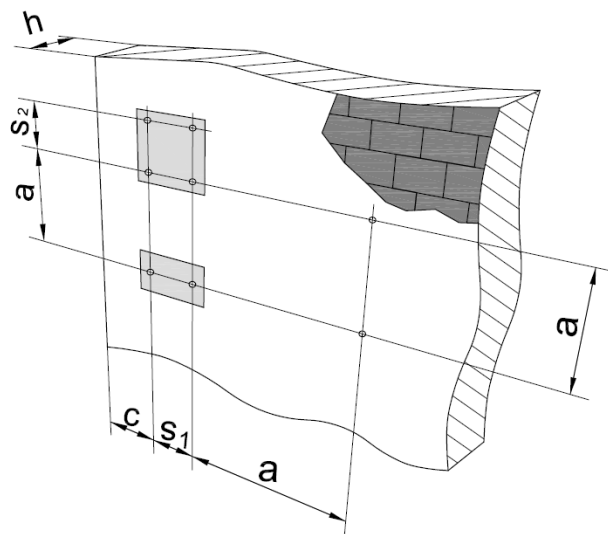

Sormat Universal Facade Plugs S-UF, S-UP and S-FP

Minimum thickness of member, minimum spacing and edge distances in masonry

Annex 8

Table 12: Geometry of hollow and perforated stones (Use category "c")

Base material	Drawing
<p>Hollow clay brick HLz 12-1,0-2DF DIN 105 EN 771-1</p>	<p>Figure 1</p>
<p>Hollow sand-lime brick KS L 12-1,4-8DF DIN 105 EN 771-2</p>	<p>Figure 2</p>

Sormat Universal Facade Plugs S-UF, S-UP and S-FP

Geometry of stones

Annex 9