



European Technical Approval ETA-12/0554

English translation prepared by DIBt - Original version in German language

Handelsbezeichnung
Trade name

fischer Injektionssystem FIS HT zur Verankerung im Mauerwerk
fischer injection system FIS HT for use in masonry

Zulassungsinhaber
Holder of approval

fischerwerke GmbH & Co. KG
Weinhalde 14-18
72178 Waldachtal
DEUTSCHLAND

Zulassungsgegenstand
und Verwendungszweck
*Generic type and use
of construction product*

Verbunddübel zur Verankerung im Mauerwerk
Injection anchor for use in masonry

Geltungsdauer:
Validity:

vom
from
bis
to

11 December 2012
26 November 2015

Herstellwerk
Manufacturing plant

fischerwerke

Diese Zulassung umfasst
This Approval contains

23 Seiten einschließlich 15 Anhänge
23 pages including 15 annexes

I LEGAL BASES AND GENERAL CONDITIONS

- 1 This European technical approval is issued by Deutsches Institut für Bautechnik in accordance with:
 - Council Directive 89/106/EEC of 21 December 1988 on the approximation of laws, regulations and administrative provisions of Member States relating to construction products¹, modified by Council Directive 93/68/EEC² and Regulation (EC) N° 1882/2003 of the European Parliament and of the Council³;
 - *Gesetz über das In-Verkehr-Bringen von und den freien Warenverkehr mit Bauprodukten zur Umsetzung der Richtlinie 89/106/EWG des Rates vom 21. Dezember 1988 zur Angleichung der Rechts- und Verwaltungsvorschriften der Mitgliedstaaten über Bauprodukte und anderer Rechtsakte der Europäischen Gemeinschaften (Bauproduktengesetz - BauPG) vom 28. April 1998⁴, as amended by Article 2 of the law of 8 November 2011⁵;*
 - Common Procedural Rules for Requesting, Preparing and the Granting of European technical approvals set out in the Annex to Commission Decision 94/23/EC⁶;
 - Guideline for European technical approval of "Metal Injection Anchors for Use in Masonry", ETAG 029.
- 2 Deutsches Institut für Bautechnik is authorized to check whether the provisions of this European technical approval are met. Checking may take place in the manufacturing plant. Nevertheless, the responsibility for the conformity of the products to the European technical approval and for their fitness for the intended use remains with the holder of the European technical approval.
- 3 This European technical approval is not to be transferred to manufacturers or agents of manufacturers other than those indicated on page 1, or manufacturing plants other than those indicated on page 1 of this European technical approval.
- 4 This European technical approval may be withdrawn by Deutsches Institut für Bautechnik, in particular pursuant to information by the Commission according to Article 5(1) of Council Directive 89/106/EEC.
- 5 Reproduction of this European technical approval including transmission by electronic means shall be in full. However, partial reproduction can be made with the written consent of Deutsches Institut für Bautechnik. In this case partial reproduction has to be designated as such. Texts and drawings of advertising brochures shall not contradict or misuse the European technical approval.
- 6 The European technical approval is issued by the approval body in its official language. This version corresponds fully to the version circulated within EOTA. Translations into other languages have to be designated as such.

¹ Official Journal of the European Communities L 40, 11 February 1989, p. 12
² Official Journal of the European Communities L 220, 30 August 1993, p. 1
³ Official Journal of the European Union L 284, 31 October 2003, p. 25
⁴ *Bundesgesetzblatt Teil I 1998*, p. 812
⁵ *Bundesgesetzblatt Teil I 2011*, p. 2178
⁶ Official Journal of the European Communities L 17, 20 January 1994, p. 34

II SPECIFIC CONDITIONS OF THE EUROPEAN TECHNICAL APPROVAL

1 Definition of the product and intended use

1.1 Definition of the construction product

The fischer Injection system FIS HT is a bonded anchor (injection type) consisting of a mortar cartridge with fischer injection mortar FIS HT, FIS HT LOW SPEED or FIS HT HIGH SPEED, a perforated sleeve FIS HK and an anchor rod with hexagon nut and washer in the range of M8 to M16. The steel elements are made of zinc coated steel, stainless steel or high corrosion resistant steel.

The anchor rod is placed into a drilled hole filled with injection mortar and is anchored via the bond between steel element, injection mortar and masonry.

An illustration of the product and intended use is given in Annex 1.

1.2 Intended use

The anchor is intended to be used for anchorages for which requirements for mechanical resistance and stability and safety in use in the sense of the Essential Requirements 1 and 4 of Council Directive 89/106 EEC shall be fulfilled and failure of anchorages made with these products would cause risk to human life and/or lead to considerable economic consequences.

The anchor is to be used only for anchorages subject to static or quasi-static loading in solid masonry (use category b) or hollow or perforated masonry (use category c) according to Annexes 8 and 9. The mortar strength class of the masonry has to be M 2,5 according to EN 998-2:2010 at minimum.

The anchor may be used in the following service temperature ranges:

Temperature range I:	-40 °C to +80 °C	(max long term temperature +50 °C and max short term temperature +80 °C)
Temperature range II:	-40 °C to +120 °C	(max long term temperature +72 °C and max short term temperature +120 °C)

The anchor may be installed in dry or wet structures.

Regarding the injection mortar the anchor may be used in dry and wet structures (category w/w). Regarding the steel elements of the anchor following use conditions applies:

Steel elements made of zinc coated steel:

The steel elements made of electroplated or hot-dipped galvanised steel may only be used in structures subject to dry internal conditions.

Steel elements made of stainless steel A4:

The steel element made of stainless steel may be used in structures subject to dry internal conditions and also in structures subject to external atmospheric exposure (including industrial and marine environment), or exposure in permanently damp internal conditions, if no particular aggressive conditions exist. Such particular aggressive conditions are e.g. permanent, alternating immersion in seawater or the splash zone of seawater, chloride atmosphere of indoor swimming pools or atmosphere with extreme chemical pollution (e.g. in desulphurization plants or road tunnels where de-icing materials are used).

Steel elements made of high corrosion resistant steel C:

The steel element made of high corrosion resistant steel may be used in structures subject to dry internal conditions and also in structures subject to external atmospheric exposure, in permanently damp internal conditions or in other particular aggressive conditions. Such particular aggressive conditions are e.g. permanent, alternating immersion in seawater or the splash zone of seawater, chloride atmosphere of indoor swimming pools or atmosphere with chemical pollution (e.g. in desulphurization plants or road tunnels where de-icing materials are used).

The provisions made in this European technical approval are based on an assumed working life of the anchor of 50 years. The indications given on the working life cannot be interpreted as a guarantee given by the producer, but are to be regarded only as a means for choosing the right products in relation to the expected economically reasonable working life of the works.

2 Characteristics of the product and methods of verification

2.1 Characteristics of product

The anchor corresponds to the drawings and provisions given in the annexes. The characteristic material values, dimensions and tolerances of the anchor not indicated in annexes shall correspond to the respective values laid down in the technical documentation⁷ of this European technical approval.

The characteristic anchor values for the design of anchorages are given in Annex 12 to Annex 15.

The anchor is assumed to satisfy the requirements for class A1 of the characteristic reaction to fire.

Regarding resistance to fire no performance is determined.

2.2 Methods of verification

The assessment of fitness of the anchor for the intended use in relation to the requirements for mechanical resistance and stability and safety in use in the sense of the Essential Requirements 1 and 4 has been made in accordance with the "Guideline for European technical approval of Metal Injection Anchors for Use in Masonry", ETAG 029, based on the Use Categories b and c in respect of the base material and Category w/w in respect of installation and use.

In addition to the specific clauses relating to dangerous substances contained in this European technical approval, there may be other requirements applicable to the products falling within its scope (e.g. transposed European legislation and national laws, regulations and administrative provisions). In order to meet the provisions of the Construction Products Directive, these requirements need also to be complied with, when and where they apply.

⁷ The technical documentation of this European technical approval is deposited at the Deutsches Institut für Bautechnik and, as far as relevant for the tasks of the approved bodies involved in the attestation of conformity procedure, is handed over to the approved bodies.

3 Evaluation and attestation of conformity and CE marking

3.1 System of attestation of conformity

According to the Decision 97/177/EC of the European Commission⁸ System 1 of the attestation of conformity applies.

This system of attestation of conformity is defined as follows:

System 1: Certification of the conformity of the product by an approved certification body on the basis of:

- (a) Tasks for the manufacturer:
 - (1) factory production control;
 - (2) further testing of samples taken at the factory by the manufacturer in accordance with a prescribed test plan;
- (b) Tasks for the approved body:
 - (3) initial type-testing of the product;
 - (4) initial inspection of factory and of factory production control;
 - (5) continuous surveillance, assessment and approval of factory production control.

Note: Approved bodies are also referred to as "notified bodies".

3.2 Responsibilities

3.2.1 Tasks for the manufacturer

3.2.1.1 Factory production control

The manufacturer shall exercise permanent internal control of production. All the elements, requirements and provisions adopted by the manufacturer shall be documented in a systematic manner in the form of written policies and procedures, including records of results performed. This production control system shall insure that the product is in conformity with this European technical approval.

The manufacturer may only use initial/raw/constituent materials stated in the technical documentation of this European technical approval.

The factory production control shall be in accordance with the control plan⁹ which is part of the technical documentation of this European technical approval. The control plan is laid down in the context of the factory production control system operated by the manufacturer and deposited at Deutsches Institut für Bautechnik. The results of factory production control shall be recorded and evaluated in accordance with the provisions of the control plan.

3.2.1.2 Other tasks for the manufacturer

The manufacturer shall, on the basis of a contract, involve a body which is approved for the tasks referred to in section 3.1 in the field of anchors in order to undertake the actions laid down in section 3.2.2 For this purpose, the control plan referred to in sections 3.2.1.1 and 3.2.2 shall be handed over by the manufacturer to the approved body involved.

The manufacturer shall make a declaration of conformity, stating that the construction product is in conformity with the provisions of this European technical approval.

⁸ Official Journal of the European Communities L 073 of 14.03.1997

⁹ The control plan is a confidential part of the European technical approval and only handed over to the approved body involved in the procedure of attestation of conformity. See section 3.2.2.

3.2.2 Tasks for the approved bodies

The approved body shall perform the

- initial type-testing of the product,
- initial inspection of factory and of factory production control,
- continuous surveillance, assessment and approval of factory production control,

in accordance with the provisions laid down in the control plan.

The approved body shall retain the essential points of its actions referred to above and state the results obtained and conclusions drawn in a written report.

The approved certification body involved by the manufacturer shall issue an EC certificate of conformity of the product stating the conformity with the provisions of this European technical approval.

In cases where the provisions of the European technical approval and its control plan are no longer fulfilled the certification body shall withdraw the certificate of conformity and inform Deutsches Institut für Bautechnik without delay.

3.3 CE marking

The CE marking shall be affixed on each packaging of the anchor. The letters "CE" shall be followed by the identification number of the approved certification body, where relevant, and be accompanied by the following additional information:

- the name and address of the producer (legal entity responsible for the manufacture),
- the last two digits of the year in which the CE marking was affixed,
- the number of the EC certificate of conformity for the product,
- the number of the European technical approval,
- ETAG 029,
- use category (b, c, and w/w) and
- size.

4 Assumptions under which the fitness of the product for the intended use was favourably assessed

4.1 Manufacturing

The European technical approval is issued for the product on the basis of agreed data/information, deposited with Deutsches Institut für Bautechnik, which identifies the product that has been assessed and judged. Changes to the product or production process, which could result in this deposited data/information being incorrect, should be notified to Deutsches Institut für Bautechnik before the changes are introduced.

Deutsches Institut für Bautechnik will decide whether or not such changes affect the approval and consequently the validity of the CE marking on the basis of the approval and if so whether further assessment or alterations to the approval shall be necessary.

4.2 Design of anchorages

The fitness of the anchor for the intended use is given under the following conditions:

The anchorages are designed in accordance with the ETAG 029, Annex C¹⁰, Design method A under the responsibility of an engineer experienced in anchorages and masonry work.

Verifiable calculation notes and drawings are prepared taking account the relevant masonry in the region of the anchorage (nature and strength of the base materials), the loads to be transmitted and their transmission to the supports of the structure. The position of the anchor is indicated on the design drawings (e.g. position of the anchor relative to supports etc.).

The characteristic resistances are only valid for kind of bricks according to Annexes 8 and 9. The characteristic resistance for use in solid masonry are also valid for larger brick sizes and larger compressive strength of the masonry unit.

For other bricks in solid masonry and in hollow or perforated masonry, the characteristic resistance of the anchor may be determined by job site tests according to ETAG, Annex B¹¹ under consideration of the β -factor according to Annex 14, Table 10.

4.3 Installation

The fitness for use of the anchor can only be assumed if the anchor is installed as follows:

- anchor installation carried out by appropriately qualified personnel and under the supervision of the person responsible for technical matters of the site,
- use of the anchor only as supplied by the manufacturer without exchanging the components of an anchor,
- anchor installation in accordance with the manufacturer's specifications and drawings using the tools indicated in the technical documentation of this European technical approval,
- commercial standard threaded rods, washers and hexagon nuts may also be used if the following requirements are fulfilled:
 - material, dimensions and mechanical properties of the metal parts according to the specifications given in Annex 4, Table 4,
 - confirmation of material and mechanical properties of the metal parts by inspection certificate 3.1 according to EN 10204:2004, the documents should be stored,
 - marking of the threaded rod with the envisage embedment depth. This may be done by the manufacturer of the rod or the person on jobsite.
- checks before placing the anchor to ensure that the use category applies and that the characteristic values of the base material in which the anchor is to be placed, is identical with the values, which the characteristic loads apply for.
- holes to be drilled perpendicular to the surface of the base material by using a hard-metal tipped hammer drill bit,
- in case of aborted drill hole the drill hole shall be filled with mortar,
- hole cleaning and anchor installation in accordance with manufacturer's installation instructions (Annexes 6 and 7),

¹⁰ The Guideline ETAG 029, "Metal Injection Anchors for Use in Masonry, Annex C: Design Methods for Anchorages" is published in English on EOTA website www.eota.eu.

¹¹ The Guideline ETAG 029, "Metal Injection Anchors for Use in Masonry, Annex B: Recommendations for tests to be carried out on construction works" is published in English on EOTA website www.eota.eu.

- keeping the installation parameters (Annexes 3, 4 and 5),
- marking and keeping the effective anchorage depth,
- keeping edge distance and spacing according to Annex 15 without minus tolerances,
- observing the curing time according to Annex 5, Table 5 until the anchor may be loaded.

5 Indications to the manufacturer

5.1 Manufacturer's responsibilities

It is in the responsibility of the manufacturer to ensure that the information on the specific conditions according to 1 and 2 as well as sections 4.2, 4.3 and 5.2 is given to those who are concerned. This information may be made by reproduction of the respective parts of the European technical approval. In addition all installation data shall be shown clearly on the package and/or on an enclosed instruction sheet, preferably using illustration(s).

The minimum data required are:

- installation parameters according to Annexes 3 and 4,
- material and property class of metal parts according to Annex 4, Table 4,
- information on the installation procedure, including cleaning of the hole with the cleaning equipments, preferably by means of an illustration,
- exact volume of injection mortar depend on the relevant installation,
- storage temperature of anchor components, minimum and maximum temperature of the base material, processing time (open time) of the mortar and curing time until the anchor may be loaded according to Annex 5,
- identification of the manufacturing batch.

All data shall be presented in a clear and explicit form.

5.2 Recommendations regarding packaging, transport and storage

The injection cartridges shall be protected against sun radiation and shall be stored according to the manufacture's installation instructions in dry condition at temperatures of at least +5 °C to not more than +25 °C.

Mortar cartridges with expired shelf life must no longer be used.

Georg Feistel
Head of Department

beglaubigt:
Baderschneider

Anchor rods with perforated sleeve FIS HK; installation in perforated and solid brick masonry¹⁾

¹⁾Types of bricks see Annexes 8 and 9.

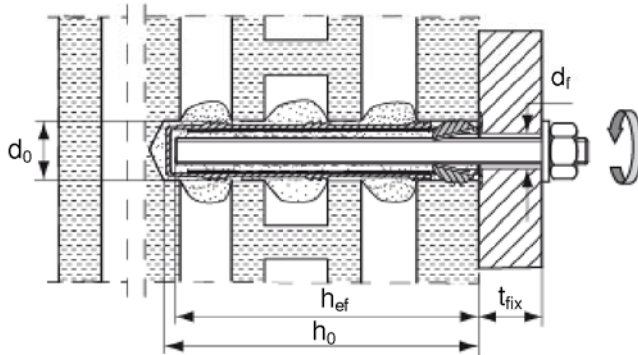

Pre-positioned anchorage

FISH 16x85 K
FIS H 16x130 K
FIS H 20x130 K
FIS H 20x200 K

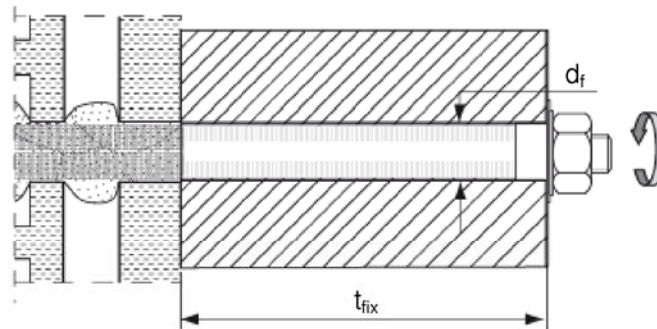

In-place anchorage

FISH 18x130/200 K
FIS H 22x130/200 K

Anchor rods without perforated sleeve FIS HK; installation in solid brick masonry¹⁾

¹⁾Types of bricks see Annexes 8 and 9.

Pre-positioned anchorage

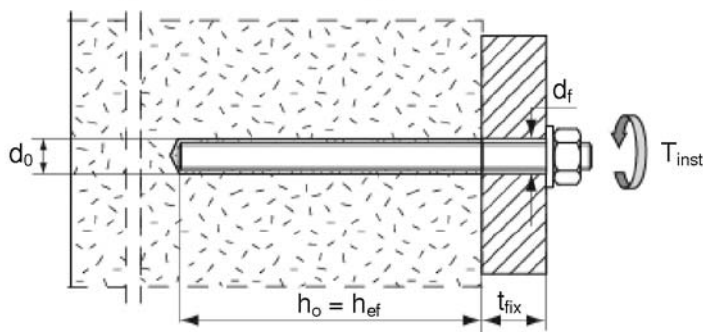

In-place anchorage

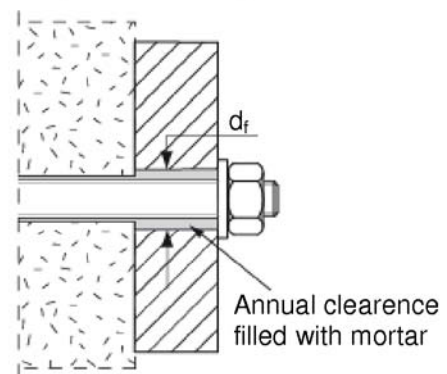

h_{ef} = effective anchorage depth
 h_o = depth of drill hole
 t_{fix} = thickness of fixure

d_o = nominal drill bit diameter
 d_f = diameter of clearance hole in the fixure
 T_{inst} = torque moment

fischer Injection system FIS HT masonry

Intended use

Annex 1

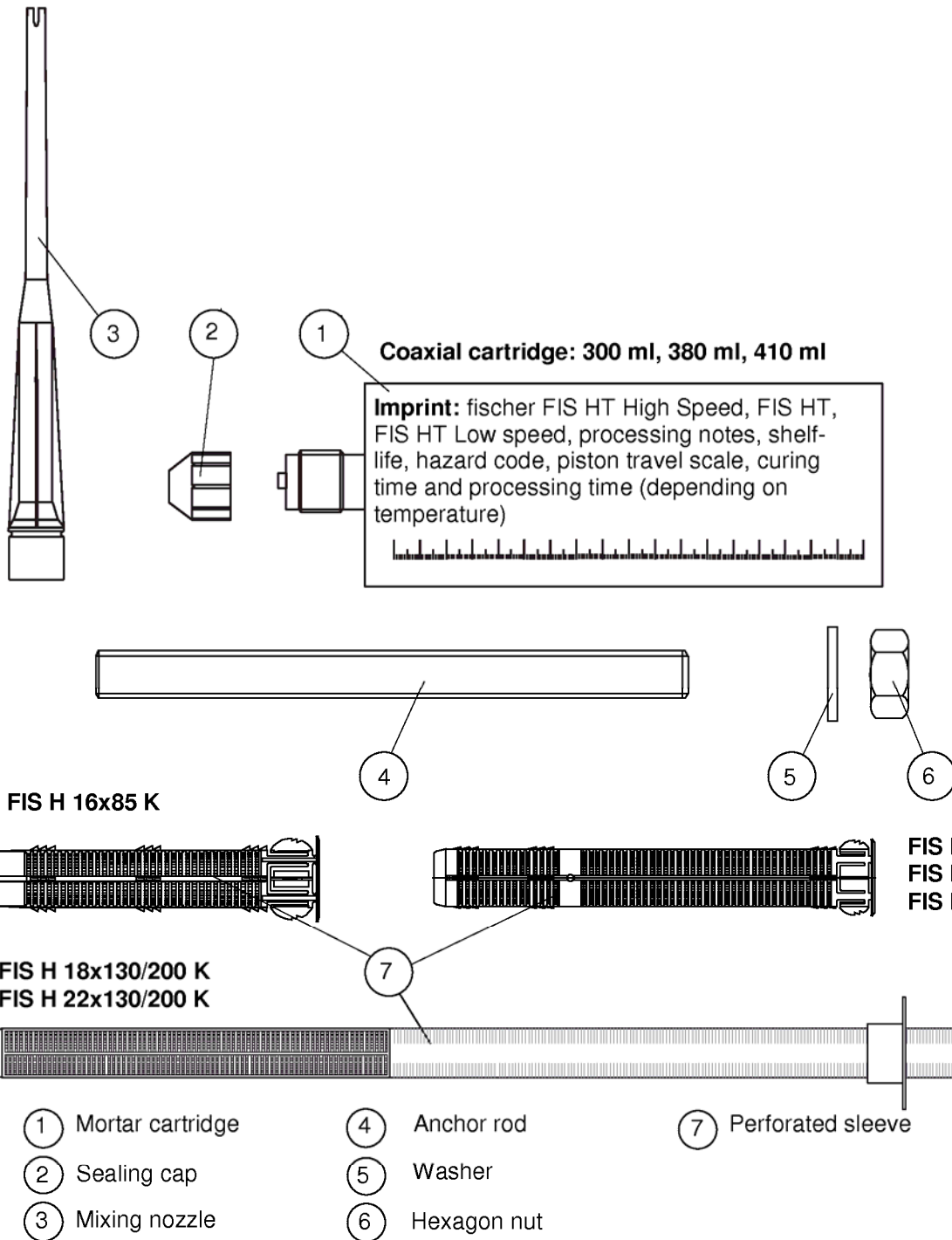

Use categories:

Base material: use category b and c (solid, hollow or perforated masonry)

Installation and use: category w / w (Installation and use in dry and wet structure)

Temperature range I: -40°C to +80°C (max. long term temperature +50°C and max. short term temperature +80°C)

Temperature range II: -40°C to +120°C (max. long term temperature +72°C and max. short term temperature +120°)

fischer Injection system FIS HT masonry

Product
Use categories

Annex 2

Anchor rods M8, M10, M12, M16

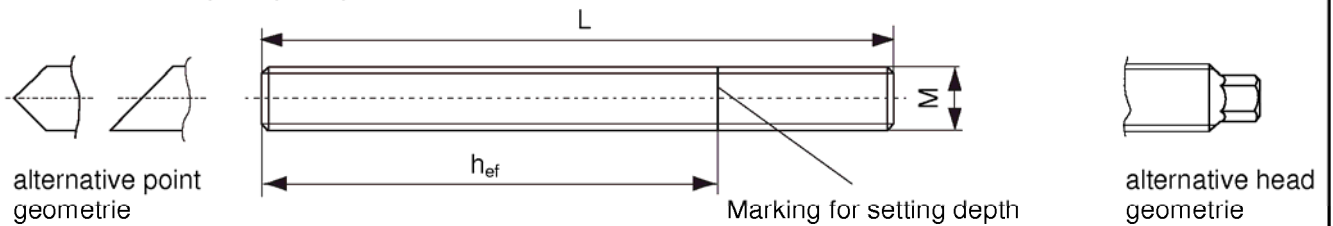

Table 1: Installation parameters anchor rods in solid bricks (without perforated sleeves)

Size		M8	M10	M12	M16
Nominal drill bit diameter	d_0 [mm]	10	12	14	18
Effective anchorage depth h_{ef} ¹⁾	$h_{ef,min}$ [mm]	50			64
Depth of drill hole $h_0 = h_{ef}$	$h_{ef,max}$ [mm]	100			
Diameter of clearance hole in the fixture	Pre-positioned $d_f \leq$ [mm]	9	12	14	18
	In-place $d_f \leq$ [mm]	11	14	16	20
Diameter of steel brush	d_b [mm]	11	13	16	20
Torque moment	$T_{inst,max}$ [Nm]	4			
Thickness of fixture	$t_{fix,max}$ [mm]	1500			

¹⁾ $h_{ef,min} \leq h_{ef} \leq h_{ef,max}$ is possible.

Steel brush



Perforated sleeves FIS H 16x85 K; FIS H 16x130 K; FIS H 20x130 K; FIS H 20x200 K

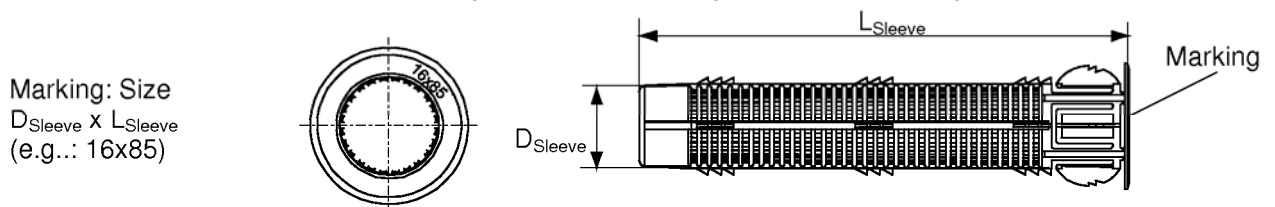

Table 2: Installation parameters anchor rods with perforated sleeves

Size	FIS HK	16x85	16x130	20x130	20x200
Nominal drill bit diameter	$d_0 = D_{Sleeve}$ [mm]	16		20	
Depth of drill hole	h_0 [mm]	95	140	140	210
Effective anchorage depth	$h_{ef,min}$ [mm]	85	110	110	180
	$h_{ef,max}$ [mm]	85	130	130	200
Size of anchor rod		M8 or M10		M12 or M16	
Diameter of steel brush ¹⁾	d_b [mm]	18		24	
Torque moment	$T_{inst,max}$ [Nm]	4 ²⁾			
Thickness of fixture	$t_{fix,max}$ [mm]	1500			

¹⁾ Only for KSL and solid blocks.

²⁾ Brick No.: 4, 5, 11 and 12.

For brick No.: 1, 2, 3, 6, 7, 8, 9 and 10: $T_{inst,max} = 2$ Nm

fischer Injection system FIS HT masonry

Installation parameters anchor rods
with perforated sleeves (pre-positioned)
Steel brush

Annex 3

Perforated sleeves FIS H 18x130/200 K and FIS H 22x130/200 K

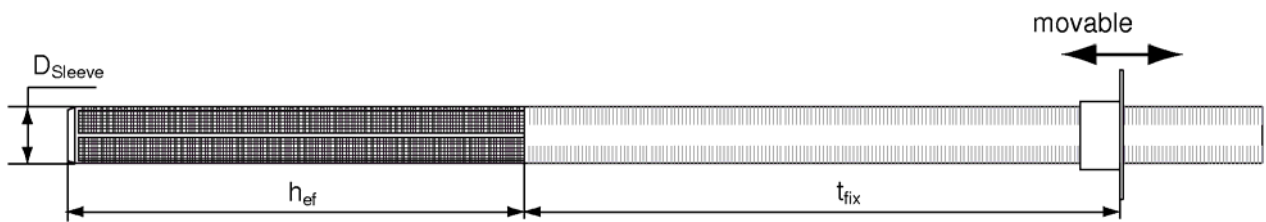

Table 3: Installation parameters anchor rods with perforated sleeves (in-place anchorage)

Size		FIS H 18x130/200 K	FIS H 22x130/200 K
Nominal drill bit diameter $d_0 = D_{\text{Sleeve}}$	d_0 [mm]	18	22
Depth of drill hole	h_0 [mm]	$135 + t_{\text{fix}}$	
Effective anchorage depth	h_{ef} [mm]	130	
Diameter of steel brush	d_b [mm]	20	24
Anchor rod size		M10 or M12	M16
Torque moment	$T_{\text{inst,max}}$ [Nm]	4 ¹⁾	
Thickness of fixture	$t_{\text{fix,max}}$ [mm]	200	

¹⁾Brick No.: 4, 5, 11 and 12. For brick No.: 1, 2, 3, 6, 7, 8, 9 and 10: $T_{\text{inst,max}} = 2 \text{ Nm}$

Talle 4: Materials

Designation	Materials		
	Steel, zinc plated	Stainless steel A4	High corrosion resistant steel C
Anchor rods	Property class 5.8 or 8.8; EN ISO 20898-1 zinc plated $\geq 5\mu\text{m}$, EN ISO 4042 A2K or hot-dip galvanised EN ISO 10684	Property class 50 or 70 EN ISO 3506 1.4401; 1.4404; 1.4578; 1.4571; 1.4439; 1.4362 EN 10088 or 1.4062 pr EN 10088:2011	Property class 50 or 80 EN ISO 3506 or property class 70 with $f_{yk}=560 \text{ N/mm}^2$ 1.4529; 1.4565 EN 10088
Washer EN ISO 7089	Zinc plated $\geq 5\mu\text{m}$, EN ISO 4042 A2K or hot-dip galvanised EN ISO 10684	1.4401; 1.4404; 1.4578; 1.4571; 1.4439; 1.4362 EN 10088	1.4529; 1.4565 EN 10088
Hexagon nut EN 24032	Property class 5 or 8; EN ISO 20898-2 zinc plated $\geq 5\mu\text{m}$, EN ISO 4042 A2K or hot-dip galvanised EN ISO 10684	Property class 50 or 70 EN ISO 3506 1.4401; 1.4404; 1.4578; 1.4571; 1.4439; 1.4362 EN 10088	Property class 50, 70 or 80 EN ISO 3506 1.4529; 1.4565 EN 10088
Perforated sleeve	PP / PE		

fischer Injection system FIS HT masonry

Installation parameters anchor rods
with perforated sleeves (in-place)
Materials

Annex 4

Table 5: Maximum processing times and minimum curing times
fischer Injection system FIS HT

FIS HT ²⁾

Masonry temperature [°C]	Minimum curing time ¹⁾ t _{cure} [Minutes]	Maximum processing time t _{gel} [Minutes]
-5 to ±0	24 hours	---
>±0 to +5	180	13
>+5 to +10	90	9
>+10 to +20	60	5
>+20 to +30	45	4
>+30 to +40	35	2

FIS HT Low Speed²⁾

Masonry temperature [°C]	Minimum curing time ¹⁾ t _{cure} [Minutes]	Maximum processing time t _{gel} [Minutes]
±0 to +5	360	---
>+5 to +10	180	20
>+10 to +20	120	10
>+20 to +30	60	6
>+30 to +40	30	4

FIS HT High Speed³⁾

Masonry temperature [°C]	Minimum curing time ¹⁾ t _{cure} [Minutes]	Maximum processing time t _{gel} [Minutes]
-5 to ±0	180	---
>±0 to +5	90	5
>+5 to +10	45	3
>+10 to +20	30	1

¹⁾For wet bricks the curing time must be doubled.

²⁾Minimum cartridge temperature +5°C.

³⁾Minimum cartridge temperature ± 0°C.

fischer Injection system FIS HT masonry

Processing times and curing times



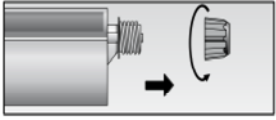
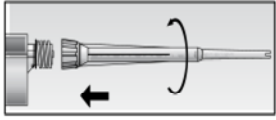
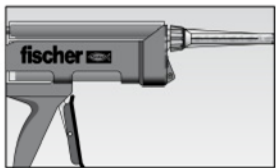
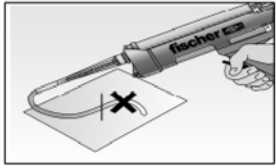

Annex 5

Installation instructions

Preparing the cartridge

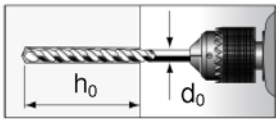
- | | | | | |
|----------|---|--|--|---|
| 1 |  | Remove the Sealing cap |  | Screw on the mixing nozzle. (the spiral in the mixing nozzle must be clearly visible) |
| 2 |  | Place the cartridge into the applicator gun. |  | Press approx. 10 cm of material out until the resin is well mixed. Don't use mortar that is not well mixed. |

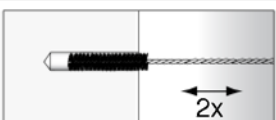
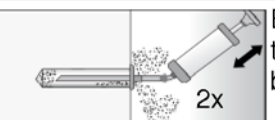
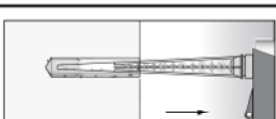
Installation in solid brick (without perforated sleeve)

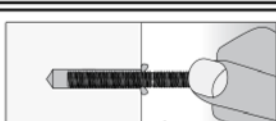
- | | | | | |
|----------|---|---|--|--|
| 3 |  | Drill the hole. Depth of drill hole h_0 and drill hole diameter d_0 see Table 1 . | | |
| 4 |  |  |  | Blow out the drill hole twice. Brush twice and blow out twice again. |
| 5 |  | Fill approx. 2/3 of the drill hole with mortar beginning from the bottom of the hole ¹⁾ |  | For in-place anchorage fill the annular clearance also with mortar. |
| 6 |  | Insert the anchor rod by hand using light turning motions. When reaching the setting depth, excess mortar must exit the drill hole. | | |

¹⁾Exact volume of mortar see manufacturer's specification.



- | | | | | |
|----------|---|--|--|--|
| 7 |  | Do not touch. Minimum curing time see Table 5 . |  | Mounting the fixture
$T_{inst,max}$
see Table 1 . |
|----------|---|--|--|--|

fischer Injection system FIS HT masonry

Installation instruction
Part 1

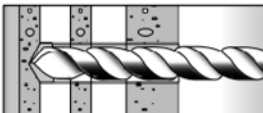
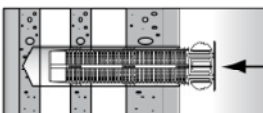
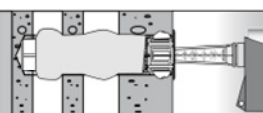
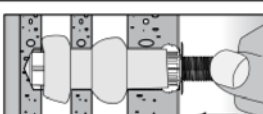

Annex 6

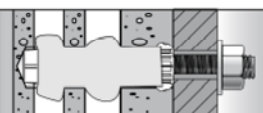
Installation in perforated or solid brick with perforated sleeve (pre-positioned anchorage)

3		<p>Drill the hole. Depth of drill hole h_0 and drill hole diameter d_0 see Table 2</p>	<p>When install perforated sleeves in solid brick or KSL, also clean the hole by blowing out and brush.</p>
4		<p>Insert the perforated sleeve flush with the surface of the masonry.</p>	 <p>Fill the perforated sleeve completely with mortar beginning from the bottom of the hole¹⁾.</p>
5		<p>Insert the anchor rod by hand using light turning motions.</p>	
6		<p>Do not touch. Minimum curing time see Table 5.</p>	 <p>Mounting the fixture $T_{inst,max}$ see Table 2</p>

¹⁾Exact volume of mortar see manufacturer's specification.

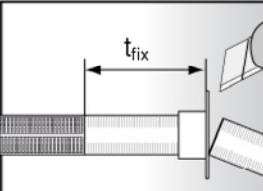
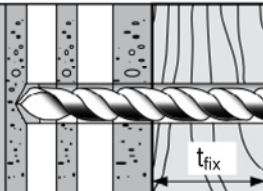
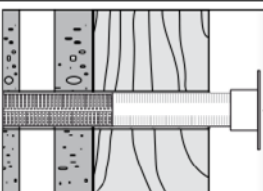
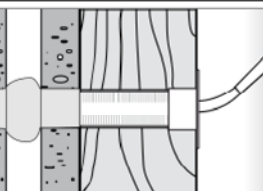
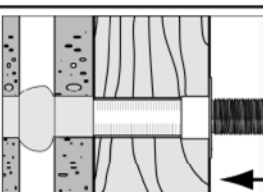
Installation in perforated or solid brick with perforated sleeve (in-place anchorage)

3	 <p>Push the movable stop up to the correct thickness of fixture and cut the overlap.</p>	 <p>Drill the hole through the fixture. Depth of drill hole (h_0+t_{fix}) and drill hole diameter see Table 3.</p>	
4		<p>Insert the perforated sleeve flush with the surface of the fixture.</p>	 <p>Fill the sleeve with mortar beginning from the bottom of the hole.¹⁾ For deep drill holes use an extension hose.</p>
5		<p>Insert the anchor rod by hand using light turning motions.</p>	
6		<p>Do not touch. Minimum curing time see Table 5.</p>	 <p>Mounting the fixture $T_{inst,max}$ see Table 3</p>

¹⁾Exact volume of mortar see manufacturer's specification.

fischer Injection system FIS HT masonry

Installation instruction
Part 2

Annex 7

Types and dimensions of blocks and bricks

Brick No. 1 (alternative dimensions)

Perforated brick
HLz 12 / 1,4 12 DF
acc. to EN 771-1
 $\rho \geq 1,4$ [kg/dm³]
 $f_b \geq 12$ [N/mm²]

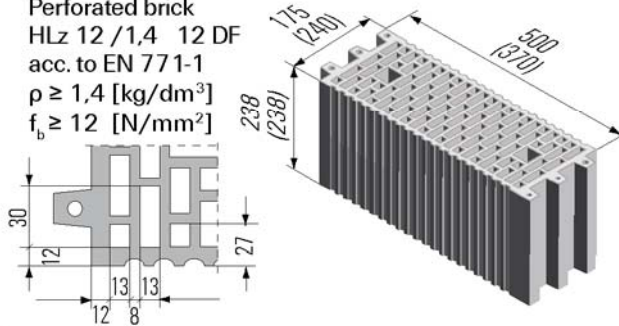

Brick No. 2 Perforated brick acc. to EN 771-1

$\rho \geq 1,2$ [kg/dm³]
 $f_b \geq 12$ [N/mm²]
 $\rho \geq 1,4$ [kg/dm³]
 $f_b \geq 28$ [N/mm²]

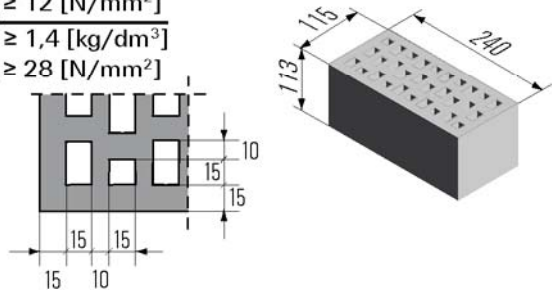

Brick No. 3

Sand-lime hollow block
acc. to EN 771-2
e.g. *KS Wemding, KSL*
 $\rho \geq 1,4$ [kg/dm³]
 $f_b \geq 12$ [N/mm²]
 $\rho \geq 1,4$ [kg/dm³]
 $f_b \geq 20$ [N/mm²]

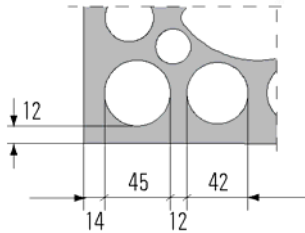
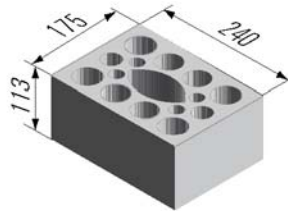

Brick No. 4

Solid sand-lime brick
1,8 NF
acc. to EN 771-2
 $\rho \geq 1,8$ [kg/dm³]
 $f_b \geq 10$ [N/mm²]
 $\rho \geq 1,8$ [kg/dm³]
 $f_b \geq 20$ [N/mm²]

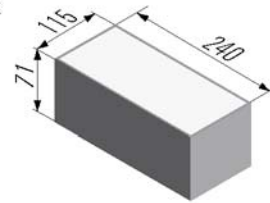

Brick No. 5

Solid brick
acc. to EN 771-2
 $\rho \geq 1,8$ [kg/dm³]
 $f_b \geq 10$ [N/mm²]
 $\rho \geq 1,8$ [kg/dm³]
 $f_b \geq 16$ [N/mm²]

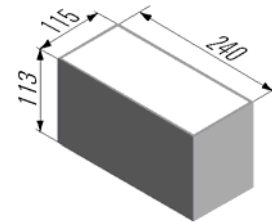

Brick No. 6

Light-weight concrete hollow block
e.g. NF-P 14-301,
acc. to EN 771-3,
e.g. *Sepa Parpaing*
 $\rho \geq 1,0$ [kg/dm³]
 $f_b \geq 6,0$ [N/mm²]

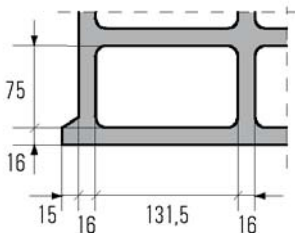
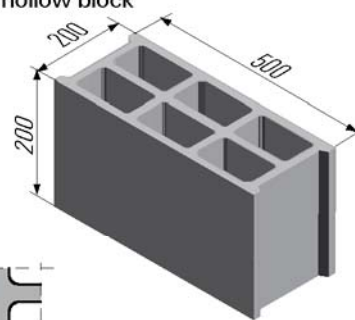

Brick No. 7

Perforated block form B
HLz e.g. NF-P 13-301,
acc. to EN 771-1,
e.g.
Bouyer Leroux BGV
 $\rho \geq 0,7$ [kg/dm³]
 $f_b \geq 8,0$ [N/mm²]

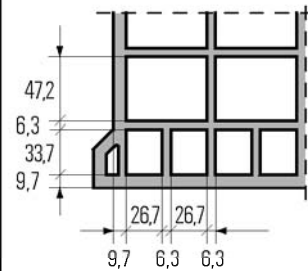
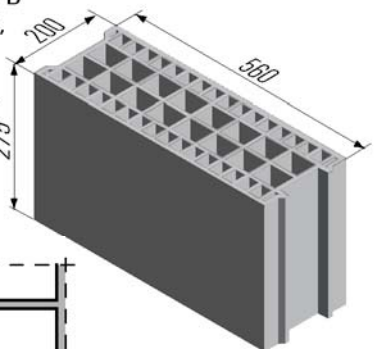

fischer Injection system FIS HT masonry

Types and dimensions of blocks
and bricks (Part 1)

Annex 8

Types and dimensions of blocks and bricks

Brick No. 8

Perforated block form B
HLz e.g. NF-P 13-301,
acc. to EN 771-1,
e.g. *Imery Optibric*
 $\rho \geq 0,6$ [kg/dm³]
 $f_b \geq 8,0$ [N/mm²]

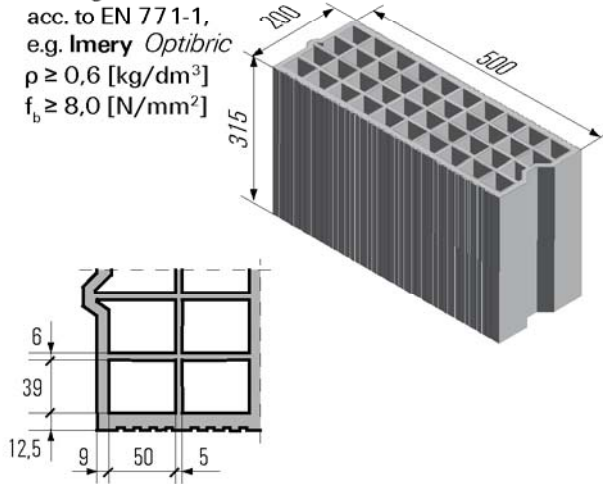

Brick No. 9

Perforated block form B
HLz e.g. NF-P 13-301,
acc. to EN 771-1,
e.g. *Terreal Gelimatic*
 $\rho \geq 0,7$ [kg/dm³]
 $f_b \geq 8,0$ [N/mm²]

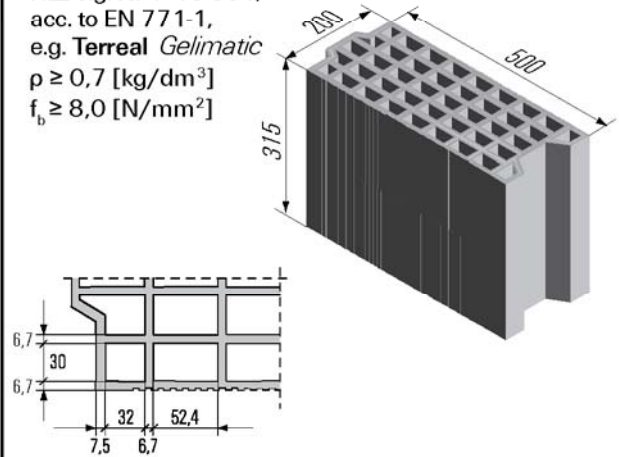

Brick No. 10

Perforated block form B
HLz e.g. NF-P 13-301,
acc. to EN 771-1,
e.g. *Wienerberger
Porotherm GFR20 Th*
 $\rho \geq 0,7$ [kg/dm³]
 $f_b \geq 10$ [N/mm²]

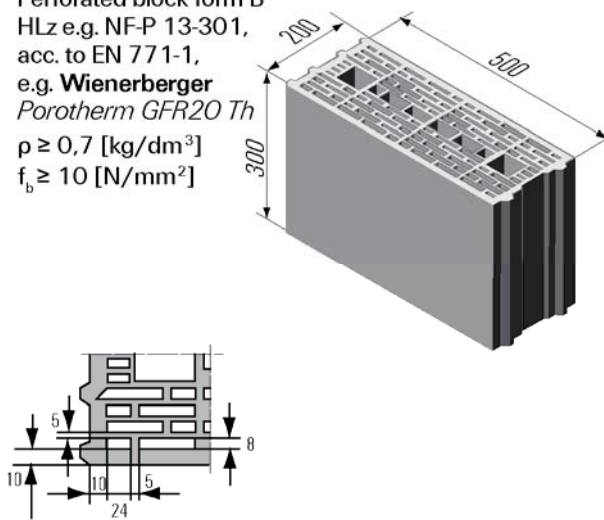

Brick No. 11

Solid light-weight
concrete block
Vbl 2/0,6
 $\rho \geq 0,6$ [kg/dm³]
 $f_b \geq 2,0$ [N/mm²]

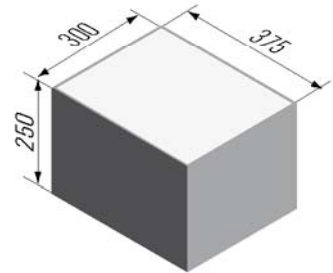

Brick No. 12

Solid sand-lime block
acc. to EN 771-2
 $\rho \geq 2,0$ [kg/dm³]
 $f_b \geq 10$ [N/mm²]
 $\rho \geq 2,0$ [kg/dm³]
 $f_b \geq 28$ [N/mm²]

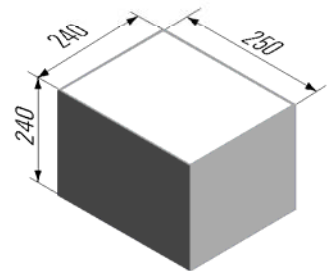





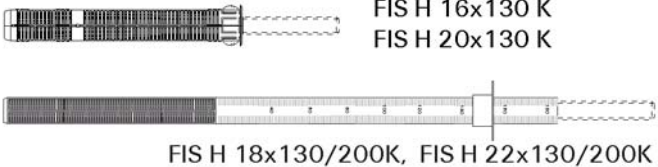
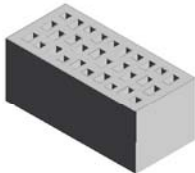

fischer Injection system FIS HT masonry

Types and dimensions of
blocks and bricks (Part 2)

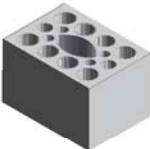
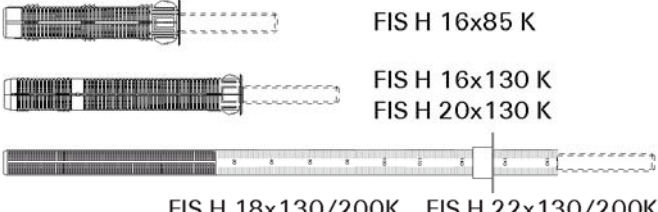
Annex 9

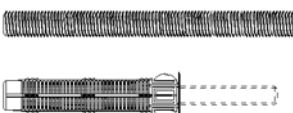
Table 6.1: Allocation of anchor rods¹⁾, perforated sleeves¹⁾ and bricks

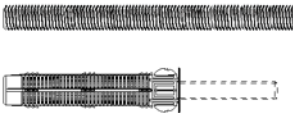
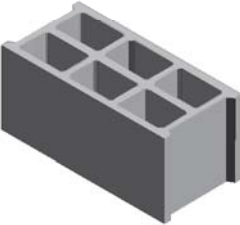
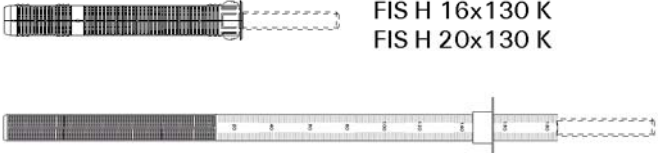
Bricks	Valid anchor rods and perforated sleeves
 <p>No.1</p>	 <p>FIS H 16x130 K FIS H 20x130 K FIS H 18x130/200K, FIS H 22x130/200K</p>
 <p>No.2</p>	 <p>FIS H 16x 85 K</p>
 <p>No.3</p>	 <p>FIS H 16x85 K FIS H 16x130 K FIS H 20x130 K FIS H 18x130/200K, FIS H 22x130/200K</p>
 <p>No.4</p>	 <p>M8; M10; M12; M16 FIS H 16x85 K</p>
 <p>No.5</p>	 <p>M8; M10; M12; M16 FIS H 16x85 K</p>
 <p>No.6</p>	 <p>FIS H 16x130 K FIS H 20x130 K FIS H 18x130/200K, FIS H 22x130/200K</p>







¹⁾Other combinations can be use after job site tests acc. to ETAG 029, Annex B.
The β - factor for this job site tests are given in **Table 10**.

fischer Injection system FIS HT masonry

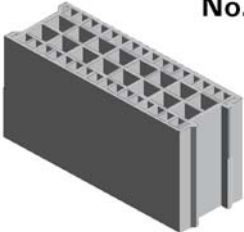
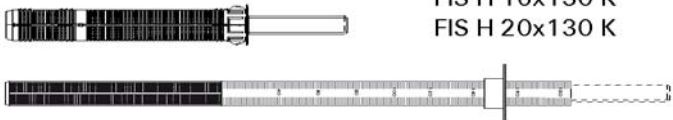
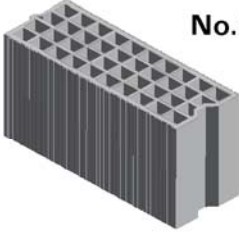
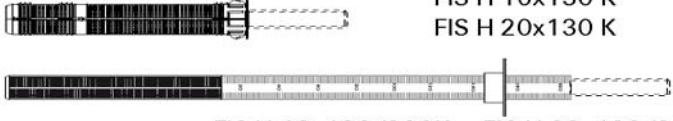
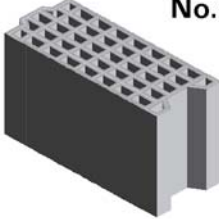
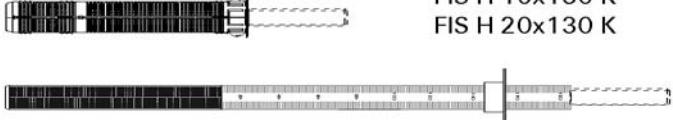
Allocation of anchor rods, perforated sleeves and bricks
(Part 1)

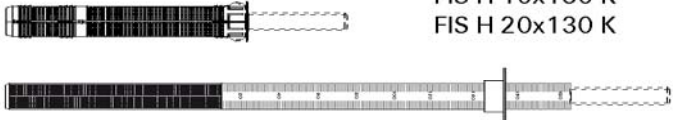
Annex 10

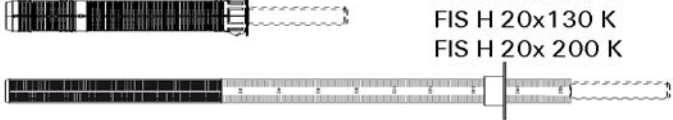
Table 6.2: Allocation of anchor rods¹⁾, perforated sleeves¹⁾ and bricks

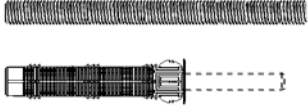
Bricks	Valid anchor rods and perforated sleeves
<p>No.7</p> 	 <p>FIS H 16x130 K FIS H 20x130 K</p> <p>FIS H 18x130/200K, FIS H 22x130/200K</p>
<p>No.8</p> 	 <p>FIS H 16x130 K FIS H 20x130 K</p> <p>FIS H 18x130/200K, FIS H 22x130/200K</p>
<p>No.9</p> 	 <p>FIS H 16x130 K FIS H 20x130 K</p> <p>FIS H 18x130/200K, FIS H 22x130/200K</p>
<p>No.10</p> 	 <p>FIS H 16x130 K FIS H 20x130 K</p> <p>FIS H 18x130/200K, FIS H 22x130/200K</p>
<p>No.11</p> 	 <p>FIS H 16x130 K FIS H 20x130 K FIS H 20x 200 K</p> <p>FIS H 18x130/200K, FIS H 22x130/200K</p>
<p>No.12</p> 	 <p>M8; M10; M12; M16</p> <p>FIS H 16x85 K</p>

¹⁾ Other combinations can be use after job site tests acc. to ETAG 029, Annex B.
The β - factor for this job site tests are given in **Table 10**.

fischer Injection system FIS HT masonry

Allocation of anchor rods, perforated sleeves and bricks
(Part 2)

Annex 11

Table 7.1: Characteristic values to tension load and shear load

Brick No.	Desity ρ [kg/dm ³] - Compressive strength f_b [N/mm ²]	Sleeve FIS H...K	Anchor size	Effective anchorage depth		Temperature range		Characteristic resistance V_{Rk} [kN] ²⁾	
				$h_{ef,min}$ [mm]	$h_{ef,max}$ [mm]	I Charac- teristic resistance N_{Rk} [kN] ¹⁾	II Charac- teristic resistance N_{Rk} [kN] ¹⁾		
1	$p \geq 1,4$ $f_b \geq 12$	16x130	M8/M10	110	130	2,0	1,5	2,0	
		18x130/200	M10/M12	130	---				
		20x130 ⁴⁾	M12/M16	110	130	3,5	3,0		
		22x130/200	M16	130	---				
2	$p \geq 1,2/f_b \geq 12$ $p \geq 1,4/f_b \geq 28$	16x85	M8/M10	85	---	2,0	1,5	3,5	
		16x85	M8/M10	85	---	3,5	3,0	6,0	
3	$p \geq 1,4$ $f_b \geq 12$	16x85	M8/M10	85	---	2,5	2,0	4,5	
		16x130	M8/M10	110	130				
		18x130/200	M10/M12	130	---	3,0	2,5		
		20x130 ⁴⁾	M12/M16	110	130				
	$p \geq 1,4$ $f_b \geq 20$	16x85	M8/M10	85	---	3,5	3,0	6,0	
		16x130	M8/M10	110	130				
		18x130/200	M10/M12	130	---	4,5	4,0		
		20x130 ⁴⁾	M12/M16	110	130				
4	$p \geq 1,8$ $f_b \geq 10$	without	M8	50	100	1,5	1,2	2,5	
			M10	50	100				
			M12	50	100	1,5	1,5		
			M16	64	100	2,0			
	$p \geq 1,8$ $f_b \geq 20$	without	M8	50	100	2,0	1,5	3,5	
			M10	50	100				
			M12	50	100	2,5	2,0		
			M16	64	100	2,5			
5	$p \geq 1,8$ $f_b \geq 10$	without	M8	50	100	1,5	1,5	2,5	
			M10	50	100				
			M12	50	100	2,0	1,5		
			M16	64	100	2,5			2,0
	$p \geq 1,8$ $f_b \geq 16$	without	16x85	M8/M10	85	---	2,0	1,5	3,0
			M8	50	100	2,0	1,5	3,0	
			M10	50	100	2,5	2,0		
			M12	50	100	3,0	2,5	3,5	
16x85	M8/M10	85	---	2,5	2,0	3,5	3,0	4,0	
				2,5	2,0	3,5	3,0	4,0	

Partial safety factor $\gamma_M = 2,5$ ³⁾

¹⁾For design according to ETAG 029, annex c: $N_{Rk} = N_{Rk,p} = N_{Rk,b} = N_{Rk,pb} = N_{Rk,s}$

²⁾For design according to ETAG 029, annex c: $V_{Rk} = V_{Rk,b} = V_{Rk,c} = V_{Rk,s}$

³⁾In absence of other national regulations.

⁴⁾Alternativ FIS H 20x200 K; ($h_{ef,min} = 110$ mm)

fischer Injection system FIS HT masonry

Characteristic values to tension load
and shear load

Annex 12

Table 7.2: Characteristic values to tension load and shear load

Brick No.	Density ρ [kg/dm ³] - Compressive Strength f_b [N/mm ²]	Sleeve FIS H...K	Anchor size	Effective anchorage depth		Temperature range		Charac- Teristic Resistance V_{Rk} [kN] ²⁾
				$h_{ef,min}$ [mm]	$h_{ef,max}$ [mm]	I Charac- Teristic resistance N_{Rk} [kN] ¹⁾	II Charac- Teristic Resistance N_{Rk} [kN] ¹⁾	
6	$p \geq 1,0$ $f_b \geq 6$	16x130	M8/M10	110	130	1,2	0,9	2,5
		18x130/200	M10/M12	130	---			
		20x130 ⁴⁾	M12/M16	110	130			
		22x130/200	M16	130	---			
7	$p \geq 0,7$ $f_b \geq 8$	16x130	M8/M10	110	130	2,0	2,0	2,0
		18x130/200	M10/M12	130	---	2,5		
		20x130 ⁴⁾	M12/M16	110	130			
		22x130/200	M16	130	---			
8	$p \geq 0,6$ $f_b \geq 8$	16x130	M8/M10	110	130	1,5	1,5	2,0
		18x130/200	M10/M12	130	---	2,5		
		20x130 ⁴⁾	M12/M16	110	130			
		22x130/200	M16	130	---			
9	$p \geq 0,7$ $f_b \geq 8$	16x130	M8/M10	110	130	1,5	1,5	2,0
		18x130/200	M10/M12	130	---	2,0		
		20x130 ⁴⁾	M12/M16	110	130			3,0
		22x130/200	M16	130	---			
10	$p \geq 1,8$ $f_b \geq 10$	16x130	M8/M10	110	130	2,5	2,0	1,5
		18x130/200	M10/M12	130	---	3,5		
		20x130 ⁴⁾	M12/M16	110	130			3,5
		22x130/200	M16	130	---			
11	$p \geq 0,6$ $f_b \geq 2$	16x130	M8/M10	110	130	2,0	1,5	1,5
		18x130/200	M10/M12	130	---			
		20x130 ⁴⁾	M12/M16	110	130	2,5	2,0	
		22x130/200	M16	130	---			
		20x200	M12/M16	180	200	3,5	3,0	1,5
12	$p \geq 2,0$ $f_b \geq 10$	without	M8	50	100	5,0	4,0	2,5
			M10	50	100			
			M12	50	100			
			M16	64	100			
		16x85	M8/M10	85	---			
	$p \geq 1,8$ $f_b \geq 16$	without	M8	50	100	9,0	7,5	4,5
			M10	50	100			
			M12	50	100			
			M16	64	100			
		16x85	M8/M10	85	---			

Partial safety factor $\gamma_M = 2,5$ ³⁾

¹⁾For design according to ETAG 029, annex c: $N_{Rk} = N_{Rk,p} = N_{Rk,b} = N_{Rk,pb} = N_{Rk,s}$

²⁾For design according to ETAG 029, annex c: $V_{Rk} = V_{Rk,b} = V_{Rk,c} = V_{Rk,s}$

³⁾In absence of other national regulations

⁴⁾Alternativ FIS H 20x200 K; ($h_{ef,min} = 110$ mm))

fischer Injection system FIS HT masonry

Characteristic values to tension load
and shear load

Annex 13

Table 8: Characteristic bending moments

Size				M8	M10	M12	M16
Characteristic bending moment $M^0_{Rk,s}$	Property class	5.8	[Nm]	19	37	65	166
		8.8	[Nm]	30	60	105	266
	Stainless steel A4	50	[Nm]	19	37	65	166
		70	[Nm]	26	52	92	232
	high corrosion-resistant steel C	50	[Nm]	19	37	65	166
		70 ²⁾	[Nm]	26	52	92	232
		80	[Nm]	30	60	105	266
	Partial safety Factor ¹⁾ $\gamma_{Ms,v}$	Property class	5.8	[-]	1,25		
8.8			[-]	1,25			
Stainless steel A4		50	[-]	2,38			
		70	[-]	1,56			
high corrosion-resistant steel C		50	[-]	2,38			
		70 ²⁾	[-]	1,25			
		80	[-]	1,33			

¹⁾If no other national regulations exist.

²⁾ $f_{uk} = 700 \text{ N/mm}^2$; $f_{yk} = 560 \text{ N/mm}^2$

Table 9: Displacements under tension- and shear load

	N [kN]	δ_{N0} [mm]	$\delta_{N\infty}$ [mm]	V [kN]	δ_{V0} [mm]	$\delta_{V\infty}$ [mm]
Solid bricks ¹⁾	$\frac{N_{Rk}}{1,4 * \gamma_M}$	0,03	0,06	$\frac{V_{Rk}}{1,4 * \gamma_M}$	0,59	0,88
Perforated bricks ²⁾					1,71	2,56
Brick No. 6					6,44	9,66

¹⁾Brick No.: 4, 5, 11, 12

²⁾Brick No.: 1, 2, 3, 7, 8, 9, 10

Table 10: β - Factors for job site tests according to ETAG 029, Annex B

Brick No.	Temperature range I	Temperature range II
4, 5, 12	0,60	0,50
1, 2, 3, 7, 8, 9, 10, 11	0,86	0,72
6	0,75	0,63

fischer Injection system FIS HT masonry

Characteristic bending moments
Displacements
 β – factors for job site tests

Annex 14

Table 11: Edge distances and spacing
(Installation with and without sleeves)

Brick No.	Anchor size											
	M8			M10			M12			M16		
	C_{min} [mm]	S_{min} [mm]	S_{cr} [mm]	C_{min} [mm]	S_{min} [mm]	S_{cr} [mm]	C_{min} [mm]	S_{min} [mm]	S_{cr} [mm]	C_{min} [mm]	S_{min} [mm]	S_{cr} [mm]
1	80	100	500	80	100	500	80	120	500	80	120	500
1 (alternative dimensions)	80	100	370	80	100	370	80	120	370	80	120	370
2	80	100	240	80	100	240	80	120	240	80	120	240
3	80	100	240	80	100	240	80	120	240	80	120	240
4	80	50	160	80	50	200	80	50	240	80	55	320
5	80	50	160	80	50	200	80	50	240	80	55	320
6	80	100	490	80	100	490	80	120	490	80	120	490
7	80	100	560	80	100	560	80	120	560	80	120	560
8	80	100	500	80	100	500	80	120	500	80	120	500
9	80	100	500	80	100	500	80	120	500	80	120	500
10	80	100	500	80	100	500	80	120	500	80	120	500
11	80	50	160	80	50	200	80	60	240	80	60	320
12	80	50	160	80	50	200	80	50	240	80	55	320

$C_{min} = C_{cr}$

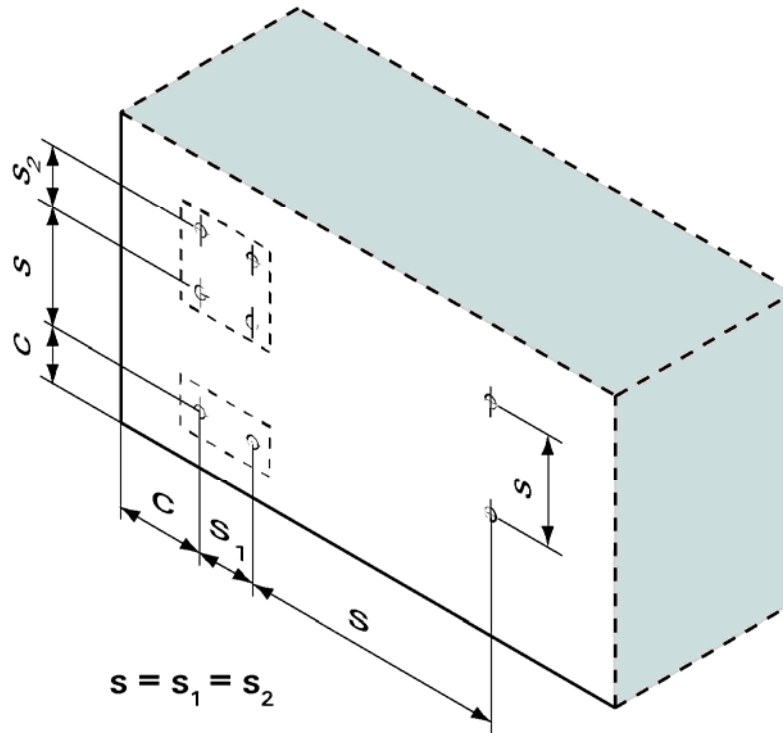

fischer Injection system FIS HT masonry

Edge distance and spacing

Annex 15