



## European Technical Approval ETA-12/0042

English translation prepared by DIBt - Original version in German language

Handelsbezeichnung <i>Trade name</i>	Würth Kunststoffdübel ZEBRA Shark W-ZX 8 und ZEBRA Shark W-ZX 10 <i>Würth plastic anchor ZEBRA Shark W-ZX 8 and ZEBRA Shark W-ZX 10</i>
Zulassungsinhaber <i>Holder of approval</i>	Adolf Würth GmbH & Co. KG Reinhold-Würth-Straße 12-17 74653 Künzelsau DEUTSCHLAND
Zulassungsgegenstand und Verwendungszweck <i>Generic type and use of construction product</i>	Kunststoffdübel als Mehrfachbefestigung von nichttragenden Systemen zur Verankerung im Beton <i>Plastic anchor for multiple use in concrete for non-structural applications</i>
Geltungsdauer: <i>Validity:</i>	vom <i>from</i> 1 March 2012 bis <i>to</i> 1 March 2017
Herstellwerk <i>Manufacturing plant</i>	Herstellwerk 2

Diese Zulassung umfasst  
*This Approval contains*

16 Seiten einschließlich 6 Anhänge  
*16 pages including 6 annexes*

## I LEGAL BASES AND GENERAL CONDITIONS

- 1 This European technical approval is issued by Deutsches Institut für Bautechnik in accordance with:
  - Council Directive 89/106/EEC of 21 December 1988 on the approximation of laws, regulations and administrative provisions of Member States relating to construction products<sup>1</sup>, modified by Council Directive 93/68/EEC<sup>2</sup> and Regulation (EC) N° 1882/2003 of the European Parliament and of the Council<sup>3</sup>;
  - *Gesetz über das In-Verkehr-Bringen von und den freien Warenverkehr mit Bauprodukten zur Umsetzung der Richtlinie 89/106/EWG des Rates vom 21. Dezember 1988 zur Angleichung der Rechts- und Verwaltungsvorschriften der Mitgliedstaaten über Bauprodukte und anderer Rechtsakte der Europäischen Gemeinschaften (Bauproduktengesetz - BauPG) vom 28. April 1998<sup>4</sup>, as amended by law of 31 October 2006<sup>5</sup>;*
  - Common Procedural Rules for Requesting, Preparing and the Granting of European technical approvals set out in the Annex to Commission Decision 94/23/EC<sup>6</sup>;
  - Guideline for European technical approval of "Plastic Anchors for Multiple Use in Concrete and Masonry for Non-structural Applications - Part 1: General", ETAG 020-01.
- 2 Deutsches Institut für Bautechnik is authorized to check whether the provisions of this European technical approval are met. Checking may take place in the manufacturing plant. Nevertheless, the responsibility for the conformity of the products to the European technical approval and for their fitness for the intended use remains with the holder of the European technical approval.
- 3 This European technical approval is not to be transferred to manufacturers or agents of manufacturers other than those indicated on page 1, or manufacturing plants other than those indicated on page 1 of this European technical approval.
- 4 This European technical approval may be withdrawn by Deutsches Institut für Bautechnik, in particular pursuant to information by the Commission according to Article 5(1) of Council Directive 89/106/EEC.
- 5 Reproduction of this European technical approval including transmission by electronic means shall be in full. However, partial reproduction can be made with the written consent of Deutsches Institut für Bautechnik. In this case partial reproduction has to be designated as such. Texts and drawings of advertising brochures shall not contradict or misuse the European technical approval.
- 6 The European technical approval is issued by the approval body in its official language. This version corresponds fully to the version circulated within EOTA. Translations into other languages have to be designated as such.

<sup>1</sup> Official Journal of the European Communities L 40, 11 February 1989, p. 12

<sup>2</sup> Official Journal of the European Communities L 220, 30 August 1993, p. 1

<sup>3</sup> Official Journal of the European Union L 284, 31 October 2003, p. 25

<sup>4</sup> *Bundesgesetzblatt Teil I 1998*, p. 812

<sup>5</sup> *Bundesgesetzblatt Teil I 2006*, p. 2407, 2416

<sup>6</sup> Official Journal of the European Communities L 17, 20 January 1994, p. 34

## II SPECIFIC CONDITIONS OF THE EUROPEAN TECHNICAL APPROVAL

### 1 Definition of product/ products and intended use

#### 1.1 Definition of the construction product

The Würth Plastic Anchor ZEBRA Shark in the sizes W-ZX 8 and W-ZX 10 is plastic anchor consisting of a plastic sleeve made of polyamide and an accompanying specific screw of galvanised steel or stainless steel.

The plastic sleeve is expanded by screwing in the specific screw which presses the sleeve against the wall of the drilled hole.

The installed anchor is shown in Annex 1.

#### 1.2 Intended use

The anchor is intended to be used for anchorages for which requirements for safety in use in the sense of the Essential Requirement 4 of Council Directive 89/106/EEC shall be fulfilled and failure of the fixture represents an immediate risk to human life.

The anchor is to be used only for multiple fixing for non-structural applications.

The anchor is to be used for pre-positioned anchorages.

The base material may consist of use category "a" as given in the following Table:

Use category	Anchor type	Remarks
a	ZEBRA Shark W-ZX 8 and ZEBRA Shark W-ZX 10	<ul style="list-style-type: none"> <li>Reinforced or unreinforced normal weight concrete</li> <li>Strength class C12/15 at minimum and C50/60 at maximum according to EN 206-1:2000-12</li> <li>Cracked and non-cracked concrete</li> <li>The anchor ZEBRA Shark W-ZX 10 may also be used with requirements related to resistance to fire according 4.2.2.</li> </ul>

#### Specific screws of galvanized steel:

The specific screws made of galvanized steel may only be used in structures subject to dry internal conditions.

#### Specific screws of stainless steel:

The specific screw made of stainless steel may be used in structures subject to dry internal conditions and also in structures subject to external atmospheric exposure (including industrial and marine environment), or exposure in permanently damp internal conditions, if no particular aggressive conditions exist. Such particular aggressive conditions are e.g. permanent, alternating immersion in seawater or the splash zone of seawater, chloride atmosphere of indoor swimming pools or atmosphere with extreme chemical pollution (e.g. in desulphurization plants or road tunnels where de-icing materials are used).

The anchor may be used in the following temperature range:

Temperature range a):      -40 °C to +40 °C      (max long term temperature +24 °C and max short term temperature +40 °C)

The provisions made in this European Technical Approval are based on an assumed working life of the anchor of 50 years. The indications given on the working life cannot be interpreted as a guarantee given by the producer, but are to be regarded only as a means for choosing the right products in relation to the expected economically reasonable working life of the works.

## **2 Characteristics of the product and methods of verification**

### **2.1 Characteristics of the product**

The anchor corresponds to the drawings and information given in Annexes 2, 3 and 4. The characteristic material values, dimensions and tolerances of the anchor not given in these Annexes shall correspond to the respective values laid down in the technical documentation<sup>7</sup> of this European Technical Approval.

The characteristic values for the design of the anchorages are given in Annexes 4 to 6.

Each anchor is to be marked with the identifying mark, the type, the diameter and the length of the anchor according to Annex 3.

The anchor shall only be packaged and supplied as a complete unit.

### **2.2 Methods of verification**

The assessment of the fitness of the anchor for the intended use in relation to the requirements for safety in use in the sense of the Essential Requirement 4 has been made in compliance with the Guideline for European Technical Approval of "Plastic Anchors for Multiple Use in Concrete and Masonry for Non-structural Applications", ETAG 020,

- Part 1: "General" and
- Part 2: "Plastic Anchors for Use in Normal Weight Concrete"

based on the use category "a".

In addition to the specific clauses relating to dangerous substances contained in this European Technical Approval, there may be other requirements applicable to the products falling within its scope (e. g. transposed European legislation and national laws, regulations and administrative provisions). In order to meet the provisions of the Construction Products Directive, these requirements need also to be complied with, when and where they apply.

<sup>7</sup>

The technical documentation of this European Technical Approval is deposited at the Deutsches Institut für Bautechnik and, as far as relevant for the tasks of the approved bodies involved in the attestation of conformity procedure, is handed over to the approved bodies.

### 3 Evaluation and attestation of conformity and CE marking

#### 3.1 System of attestation of conformity

According to the decision 97/463/EG of the European Commission<sup>8</sup> the system 2(ii) (referred to as system 2+) of attestation of conformity applies.

This system of attestation of conformity is defined as follows.

System 2+: Declaration of conformity of the product by the manufacturer on the basis of:

- (a) Tasks for the manufacturer:
  - (1) initial type-testing of the product;
  - (2) factory production control;
  - (3) testing of samples taken at the factory in accordance with a prescribed control plan.
- (b) Tasks for the approved body:
  - (4) certification of factory production control on the basis of:
    - initial inspection of factory and of factory production control;
    - continuous surveillance, assessment and approval of factory production control.

#### 3.2 Responsibilities

##### 3.2.1 Tasks of the manufacturer

###### 3.2.1.1 Factory production control

The manufacturer shall exercise permanent internal control of production. All the elements, requirements and provisions adopted by the manufacturer shall be documented in a systematic manner in the form of written policies and procedures, including records of results performed. This production control system shall insure that the product is in conformity with this European Technical Approval.

The manufacturer may only use raw materials stated in the technical documentation of this European Technical Approval.

The factory production control shall be in accordance with the control plan which is part of the technical documentation of this European Technical Approval. The control plan is laid down in the context of the factory production control system operated by the manufacturer and deposited at Deutsches Institut für Bautechnik.<sup>9</sup>

The results of factory production control shall be recorded and evaluated in accordance with the provisions of the control plan.

###### 3.2.1.2 Other tasks of manufacturer

The manufacturer shall, on the basis of a contract, involve a body which is approved for the tasks referred to in section 3.1 in the field of anchors in order to undertake the actions laid down in section 3.2.2. For this purpose, the control plan referred to in sections 3.2.1.1 and 3.2.2 shall be handed over by the manufacturer to the approved body involved.

The manufacturer shall make a declaration of conformity, stating that the construction product is in conformity with the provisions of this European Technical Approval.

<sup>8</sup> Official Journal of the European Communities L 198 of 25.07.1997.

<sup>9</sup> The control plan is a confidential part of the documentation of the European Technical Approval, but not published together with the ETA and only handed over to the approved body involved in the procedure of attestation of conformity. See section 3.2.2.

### 3.2.2 Tasks of approved bodies

The approved body shall perform the

- initial inspection of factory and of factory production control,
  - continuous surveillance, assessment and approval of factory production control,
- in accordance with the provisions laid down in the control plan.

The approved body shall retain the essential points of its actions referred to above and state the results obtained and conclusions drawn in a written report.

The approved certification body involved by the manufacturer shall issue an EC certificate of conformity of the factory production control stating the conformity with the factory production control of this European Technical Approval.

In cases where the provisions of the European Technical Approval and its control plan are no longer fulfilled the certification body shall withdraw the certificate of conformity and inform Deutsches Institut für Bautechnik without delay.

### 3.3 CE marking

The CE marking shall be affixed on each packaging of the anchor. The letters "CE" shall be followed by the identification number of the approved certification body, where relevant, and be accompanied by the following additional information:

- the name and address of the producer (legal entity responsible for the manufacturer),
- the last two digits of the year in which the CE marking was affixed,
- the number of the EC certificate for the factory production control,
- the number of the European Technical Approval,
- the number of the guideline for European Technical Approval,
- use category "a".

## 4 Assumptions under which the fitness of the product for the intended use was favourably assessed

### 4.1 Manufacturing

The European Technical Approval is issued for the product on the basis of agreed data/information, deposited with Deutsches Institut für Bautechnik, which identifies the product that has been assessed and judged. Changes to the product or production process, which could result in this deposited data/information being incorrect, should be notified to Deutsches Institut für Bautechnik before the changes are introduced. Deutsches Institut für Bautechnik will decide whether or not such changes affect the ETA and consequently the validity of the CE marking on the basis of the ETA and if so whether further assessment or alterations to the ETA shall be necessary.

### 4.2 Design of anchorages

#### 4.2.1 General

Fitness for the intended use of the anchor is given under the following conditions:

- The design of anchorages is carried out in compliance with ETAG 020, Guideline for European Technical Approval of "Plastic Anchors for Multiple Use in Concrete and Masonry for Non-structural Applications", Annex C under the responsibility of an engineer experienced in anchorages.

- Verifiable calculation notes and drawings shall be prepared taking account of the loads to be anchored, the nature and strength of the base materials and the dimensions of the anchorage members as well as of the relevant tolerances.
- The anchor is to be used only for multiple fixing for non-structural applications.

Therefore the design of the fixture may specify the number  $n_1$  of fixing points to fasten the fixture and the number  $n_2$  of anchors per fixing point. Furthermore the design value of actions  $N_{Sd}$  on a fixing point to a value  $\leq n_3$  (kN) is specified up to which the strength and stiffness of the fixture are fulfilled and the load transfer in the case of excessive slip or failure of one anchor need not be taken into account in the design of the fixture.

The following default values for  $n_1$ ,  $n_2$  and  $n_3$  may be taken:

$$n_1 \geq 4; \quad n_2 \geq 1 \quad \text{and} \quad n_3 \leq 4,5 \text{ kN} \quad \text{or}$$

$$n_1 \geq 3; \quad n_2 \geq 1 \quad \text{and} \quad n_3 \leq 3,0 \text{ kN}.$$

- Shear loads acting on an anchor may be assumed to act without lever arm if both of the following conditions are fulfilled:
  - The fixture shall be made of metal and in the area of the anchorage be fixed directly to the base material either without an intermediate layer or with a levelling layer of mortar with a thickness  $\leq 3$  mm.
  - The fixture shall be in contact with the anchor over its entire thickness. (Therefore the diameter of clearance hole in the fixture  $d_f$  has to be equal or smaller than the value given in Annex 4, Table 3.)

If these two conditions are not fulfilled the lever arm is calculated according to ETAG 020, Annex C. The characteristic bending moment is given in Annex 4, Table 4.

#### 4.2.2 Resistance in concrete (use category "a")

The characteristic values of resistance of the anchor for use in concrete are given in Annexes 4 and 5. The design method is valid for cracked and non-cracked concrete.

According to the Technical Report TR 020 "Evaluation of anchorages in concrete concerning resistance to fire" it can be assumed that for fastening of facade systems the load bearing behaviour of the Würth Plastic Anchor ZEBRA Shark W-ZX 10 has a sufficient resistance to fire at least 90 minutes (R90) if the admissible load  $[F_{Rk} / (\gamma_M \cdot \gamma_F)]$  is  $\leq 0,8$  kN (no permanent centric tension load).

#### 4.2.3 Characteristic values, spacing and dimensions of anchorage member

The minimum spacing and dimensions of anchorage member according to Annex 6, Table 7 shall be observed.

#### 4.2.4 Displacement behaviour

The displacements under tension and shear loading in concrete are given in Annex 6, Table 6.

#### 4.3 Installation of anchor

The fitness for use of the anchor can only be assumed if the following conditions of installation are met:

- Anchor installation carried out by appropriately qualified personnel under the supervision of the person responsible for technical matters on site.
- Use of the anchor only as supplied by the manufacturer without exchanging any component of the anchor.
- Anchor installation in accordance with the manufacturer's specifications and drawings using the tools indicated in this European Technical Approval.
- Checks before placing the anchor, to ensure that the characteristic values of the base material in which the anchor is to be placed, is identical with the values, which the characteristic loads apply for.
- Placing drill holes without damaging the reinforcement.

- Holes to be cleaned of drilling dust.
- In case of aborted hole: New drilling at a minimum distance away of twice the depth of the aborted hole or smaller distance if the aborted drill hole is filled with high strength mortar.
- The anchor is to be used for pre-positioned anchorages:  
Depending on the range of the thickness of fixture a defined combination of plastic sleeve and special screw length is given in Annex 3, Table 1. The plastic sleeve is inserted directly into the base material by slight hammer blows and the special screw is screwed in through the fixture until the head of the screw touches the fixture. The anchor is correctly mounted, if there is no turn-through of the plastic sleeve in the drill hole and if slightly move on turning of the screw is impossible after the complete turn-in of the screw.
- Temperature during installation of the anchor  $\geq -20$  °C (plastic sleeve and base material).

#### 4.4 Job site tests according to ETAG 020, Annex B

##### 4.4.1 General

In the absence of national requirements the characteristic resistance of the plastic anchor may be determined by job site tests, if the plastic anchor has already characteristic values given in Annex 5 for the same base material as it is present on the construction works.

Furthermore job site tests for use in different concrete only if the plastic anchor has already characteristic values given in Annex 5 for use in the equivalent base material.

The characteristic resistance to be applied to a plastic anchor should be determined by means of at least 15 pull-out tests carried out on the construction work with a centric tension load acting on the plastic anchor. These tests may also performed in a laboratory under equivalent conditions as used on construction work

Execution and evaluation of the tests as well as issue of the test report and determination of the characteristic resistance should be supervised by the person responsible for execution of works on site and be carried out by a competent person.

Number and position of the plastic anchors to be tested should be adapted to the relevant special conditions of the construction work in question and, for example, in the case of blind and larger areas be increased such that a reliable information about the characteristic resistance of the plastic anchor embedded in the base material in question can be derived. The tests should take account of the unfavourable conditions of practical execution.

##### 4.4.2 Assembly

The plastic anchor to be tested shall be installed (e. g. preparation of drill hole, drilling tool to be used, drill bit, type of drilling hammer or rotation, thickness of fixture) and as far as spacing and edge distances are concerned be distributed in the same way as foreseen for the intended use.

Depending on the drilling tool hard metal hammer drill bits or hard metal percussion drill bits, respectively, according to ISO 5468 should be used. New drill bits should be used for one test series or drill bits with  $d_{\text{cut,m}} = 8,3 \text{ mm} < d_{\text{cut}} \leq 8,45 \text{ mm} = d_{\text{cut,max}}$  (ZEBRA Shark W-ZX 8) or  $d_{\text{cut,m}} = 10,25 \text{ mm} < d_{\text{cut}} \leq 10,45 \text{ mm} = d_{\text{cut,max}}$  (ZEBRA Shark W-ZX 10).



#### 4.4.3 Execution of test

The test rig used for the pull-out tests shall provide a continuous slow increase of the load, controlled by a calibrated load cell. The load shall apply perpendicular to the surface of the base material and shall be transmitted to the anchor via a hinge. The reaction forces shall be transmitted into the base material such that possible breakout of the concrete is not restricted. This condition is considered as fulfilled, if the support reaction forces are transmitted at a distance of at least 150 mm from the plastic anchors. The load shall be increased continuously in a way that the ultimate load is reached after about 1 minute. The load is measured when the ultimate load ( $N_1$ ) is achieved.

If no pull-out failure occurs, other test methods are needed, e.g. proof-loading.

#### 4.4.4 Test report

The test report shall include all information necessary to assess the resistance of the tested anchor. It shall be given to the person responsible for the design of the fastening and shall be included in the construction dossier.

The minimum data required are:

- Name of product
- Construction site, owner of building; date and location of the tests, air temperature
- Date and place of tests
- Test rig
- Type of structure to be fixed
- Base material (e.g. strength class)
- Plastic anchor and special screw
- value of the cutting diameter of hard metal hammer-drill bits, measured before and after drilling if no new drill bits are used
- Results of tests including the indication of value  $N_1$ ; mode of failure
- Tests carried out or supervised by ...; signature

#### 4.4.5 Evaluation of test results

The characteristic resistance  $F_{RK1}$  is derived from the measured values  $N_1$  as follows

$$F_{RK1} = 0,5 \cdot N_1$$

The characteristic resistance  $F_{RK1}$  has to be equal or smaller than the characteristic resistance  $F_{RK}$  which is given in the ETA for the equivalent base material

$$N_1 = \text{the mean value of the five smallest measured values at ultimate load}$$

In absence of national regulations the partial safety factors for the resistance of the plastic anchor may be taken as  $\gamma_{Mc} = 1,8$  for use in concrete.

## 5 Indications to the manufacturer

### 5.1 Responsibility of the manufacturer

It is in the responsibility of the manufacturer to ensure that the information on the specific conditions according to 1 and 2 including Annexes referred to 4 is given to those who are concerned. This information may be made by reproduction of the respective parts of the European Technical Approval. In addition, all installation data shall be shown clearly on the packaging and/or on an enclosed instruction sheet, preferably using illustrations.

The minimum data required are:

- base material for the intended use,
- ambient temperature of the base material during installation of the anchor,
- drill bit diameter ( $d_{cut}$ ),
- overall anchor embedment depth in the base material ( $h_{nom}$ ),
- minimum hole depth ( $h_0$ ),
- information on the installation procedure,
- identification of the manufacturing batch.

All data shall be presented in a clear and explicit form.

## 5.2 Packaging, transport and storage

The anchor shall only be packaged and supplied as a complete unit.

The anchor shall be stored under normal climatic conditions in its original light-proof packaging. Before installation, it shall not be extremely dried nor frozen.

Georg Feistel  
Head of Department

*beglaubigt:*  
Bürger

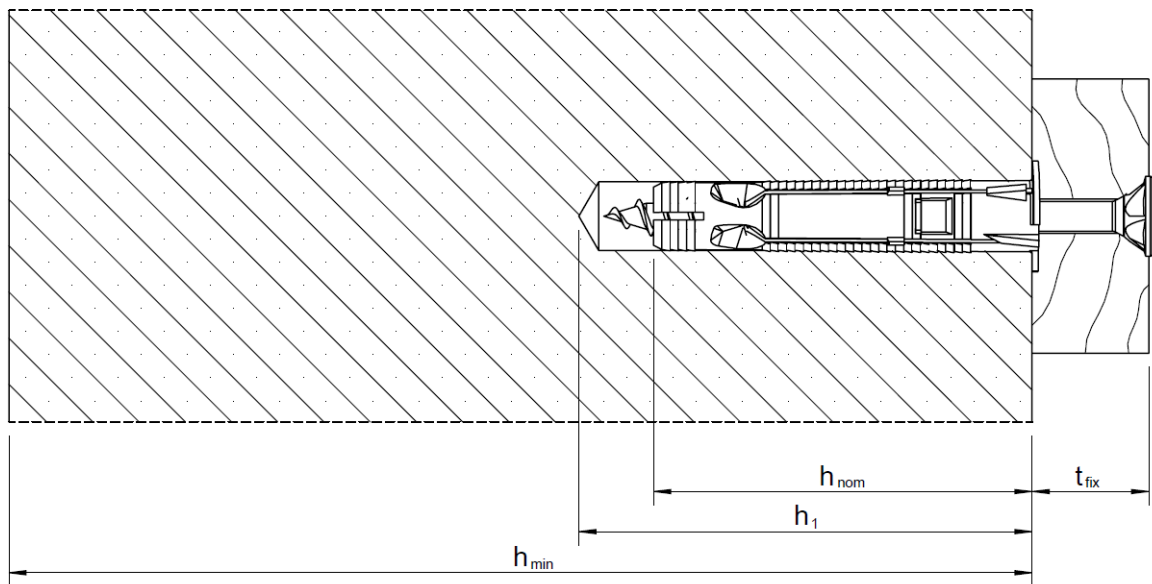

**Intended use**

Plastic anchor for **pre-positioned anchorages** for multiple use in cracked or non-cracked concrete

**Legend:**

- $h_{nom}$ : Overall plastic anchor embedment depth in the base material
- $h_1$ : Depth of drilled hole to deepest point
- $h_{min}$ : Thickness of member
- $t_{fix}$ : Thickness of fixture

Würth plastic anchor ZEBRA Shark W-ZX 8 and ZEBRA Shark W-ZX 10

Intended use

Annex 1

Plastic Sleeve ZEBRA Shark W-ZX

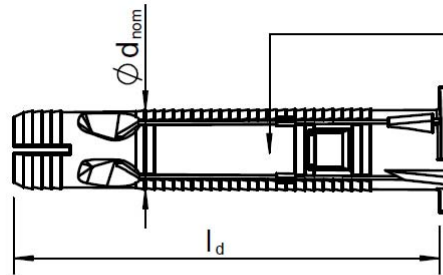

Marking:  
Identifying mark of the producer  
Ancor type  
Diameter, length  
eg.  ZEBRA W-ZX 10

Special screw ASSY-D

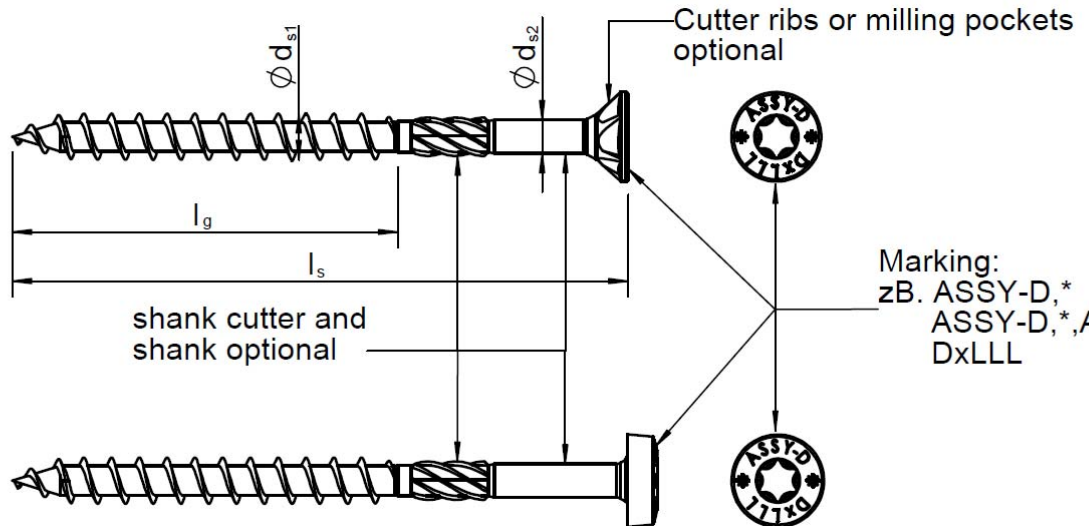

Marking:  
zB. ASSY-D,\*  
ASSY-D,\*A4  
DxLLL

Würth plastic anchor ZEBRA Shark W-ZX 8 and ZEBRA Shark W-ZX 10

Product, special screw

Annex 2

**Table 1: Anchor dimensions**

Anchor type		ZEBRA Shark W-ZX 8	ZEBRA Shark W-ZX 10
Overall plastic anchor embedment depth	$h_{nom} \geq$ [mm]	45	55
<b>Plastic sleeve</b>			
Plastic sleeve diameter	$\varnothing d_{nom} =$ [mm]	8.0	10.0
Length of plastic sleeve	$l_d$ [mm]	46	56
Flat collar diameter	$\varnothing d_k =$ [mm]	13.0	16.2
Thickness of flat collar	$l_k \geq$ [mm]	0.7	0.85
<b>Special screw ASSY-D</b>			
Screw diameter	$d_{s1} =$ [mm]	6	8
Screw diameter	$d_{s2} =$ [mm]	4.4	5.8
Length of screw	$l_s =$ [mm]	$t_{fix} + 50$	$t_{fix} + 60$
Length of thread	$l_g \geq$ [mm]	50	60
Thickness of fixture for screw $l_s = 60$ mm	$t_{fix}$ [mm]	1-10	-
Thickness of fixture for screw $l_s = 70$ mm	$t_{fix}$ [mm]	1-20	1-10
Thickness of fixture for screw $l_s = 80$ mm	$t_{fix}$ [mm]	10-30	1-20
Thickness of fixture for screw $l_s = 90$ mm	$t_{fix}$ [mm]	20-40	10-30
Thickness of fixture for screw $l_s = 100$ mm	$t_{fix}$ [mm]	30-50	20-40
Thickness of fixture for screw $l_s = 110$ mm	$t_{fix}$ [mm]	40-60	30-50
Thickness of fixture for screw $l_s = 120$ mm	$t_{fix}$ [mm]	50-70	40-60
Thickness of fixture for screw $l_s = 130$ mm	$t_{fix}$ [mm]	60-80	50-70
Thickness of fixture for screw $l_s = 140$ mm	$t_{fix}$ [mm]	70-90	60-80
Thickness of fixture for screw $l_s = 150$ mm	$t_{fix}$ [mm]	80-100	70-90
Thickness of fixture for screw $l_s = 160$ mm	$t_{fix}$ [mm]	90-110	80-100
Thickness of fixture for screw $l_s = 170$ mm	$t_{fix}$ [mm]	100-120	90-110
Thickness of fixture for screw $l_s = 200$ mm	$t_{fix}$ [mm]	130-150	120-140
Thickness of fixture for screw $l_s = 220$ mm	$t_{fix}$ [mm]	150-170	140-160
Thickness of fixture for screw $l_s = 240$ mm	$t_{fix}$ [mm]	170-190	160-180

Würth plastic anchor ZEBRA Shark W-ZX 8 and ZEBRA Shark W-ZX 10

Anchor dimensions

Annex 3

**Table 2: Materials**

Designation	Material
Plastic sleeve	Polyamide, colour brown
Special screw	Carbon steel, strength class 8.8 ( $f_{uk} \geq 800 \text{ N/mm}^2$ ; $f_{yk} \geq 640 \text{ N/mm}^2$ ), according to DIN EN ISO 4042, galvanised
	Stainless steel, strength class $\geq$ A4-70 ( $f_{uk} \geq 700 \text{ N/mm}^2$ ; $f_{yk} \geq 450 \text{ N/mm}^2$ ), 1.4401, 1.4571 or 1.4578

**Table 3: Installation parameters**

Anchor type		ZEBRA Shark W-ZX 8	ZEBRA Shark W-ZX 10
Drill hole diameter	$d_0 =$ [mm]	8	10
Overall plastic anchor embedment depth in the base material <sup>1)</sup>	$h_{nom} \geq$ [mm]	45	55
Cutting diameter of drill bit	$d_{cut} \leq$ [mm]	8.45	10.45
Depth of drilled hole to deepest point <sup>1)</sup>	$h_1 \geq$ [mm]	$l_s + 5 \text{ mm} - t_{fix}$	
Diameter of clearance hole in the fixture	$d_f \leq$ [mm]	6.5	8.5

<sup>1)</sup> See Annex 1

**Table 4: Characteristic bending resistance of the special screw in concrete**

		Galvanised steel		Stainless steel	
		ZEBRA Shark W-ZX 8	ZEBRA Shark W-ZX 10	ZEBRA Shark W-ZX 8	ZEBRA Shark W-ZX 10
Characteristic bending resistance	$M_{RK,s}$ [Nm]	5.59	14.04	4.89	12.28
Partial safety factor	$\gamma_{Ms}$ <sup>1)</sup> [mm]	1.25	1.25	1.56	1.56

<sup>1)</sup> In absence of other national regulations

Würth plastic anchor ZEBRA Shark W-ZX 8 and ZEBRA Shark W-ZX 10

Materials; Installation parameters; Characteristic bending resistance

Annex 4

**Table 5: Characteristic resistance for use in concrete**

Anchor type		Galvanised steel		Stainless steel	
		ZEBRA Shark W-ZX 8	ZEBRA Shark W-ZX 10	ZEBRA Shark W-ZX 8	ZEBRA Shark W-ZX 10
Failure of expansion element (special screw)					
Overall plastic anchor embedment depth	$h_{nom}$ [mm]	45	55	45	55
Characteristic tension resistance	$N_{Rk,s}$ [kN]	9.56	17.65	8.37	15.44
Partial safety factor	$\gamma_{Ms}^{1)}$ [-]	1.5	1.5	1.87	1.87
Characteristic shear resistance	$V_{Rk,s}$ [kN]	4.78	8.82	4.18	7.72
Partial safety factor	$\gamma_{Ms}^{1)}$ [-]	1.25	1.25	1.56	1.56
<b>Pull-out failure (plastic sleeve)</b>					
<b>Concrete <math>\geq</math> C16/20</b>					
Characteristic resistance $24^{\circ}C^{2)}$ / $40^{\circ}C^{3)}$	$N_{Rk,p}$ [kN]	1.5	3.5	1.5	3.5
Partial safety factor	$\gamma_{Mc}^{1)}$ [-]	1.8	1.8	1.8	1.8
<b>Concrete = C12/15</b>					
Characteristic resistance $24^{\circ}C^{2)}$ / $40^{\circ}C^{3)}$	$N_{Rk,p}$ [kN]	1.0	2.5	1.0	2.5
Partial safety factor	$\gamma_{Mc}^{1)}$ [-]	1.8	1.8	1.8	1.8
<b>Concrete cone failure and concrete edge failure for single anchor and anchor group</b>					
<b>Tension load<sup>4)</sup></b>					
$N_{Rk,c} = 7.2 \cdot \sqrt{f_{ck,cube}} \cdot h_{ef}^{1.5} \cdot \frac{c}{c_{cr,N}} = N_{Rk,p} \cdot \frac{c}{c_{cr,N}}$		with: $h_{ef}^{1.5} = \frac{N_{Rk,p}}{7.2 \cdot \sqrt{f_{ck,cube}}}$			
		$\frac{c}{c_{cr,N}} \leq 1$			
<b>Shear load<sup>4)</sup></b>					
$V_{Rk,c} = 0.45 \cdot \sqrt{d_{nom}} \cdot (h_{nom} / d_{nom})^{0.2} \cdot \sqrt{f_{ck,cube}} \cdot c_1^{1.5} \cdot \left(\frac{c_2}{1.5c_1}\right)^{0.5} \cdot \left(\frac{h}{1.5c_1}\right)^{0.5}$		with: $\left(\frac{c_2}{1.5 \cdot c_1}\right)^{0.5} \leq 1$			
		$\left(\frac{h}{1.5 \cdot c_1}\right)^{0.5} \leq 1$			
$c_1$	edge distance closest to the edge in loading direction				
$c_2$	edge distance perpendicular to direction 1				
$f_{ck,cube}$	nominal characteristic concrete compression strength (based on cubes), values for C50/60 at maximum				
Partial safety factor	$\gamma_{Mc1}^{1)}$ [-]				1.8

- 1) In absence of other national regulations
- 2) Maximum long term temperature
- 3) Maximum short term temperature
- 4) The design method according to ETAG 020, Annex C is to be used

Würth plastic anchor ZEBRA Shark W-ZX 8 and ZEBRA Shark W-ZX 10

Characteristic resistance for use in concrete

Annex 5

**Table 6: Displacements <sup>1)</sup> under tension and shear loading in concrete**

Anchor type	$h_{nom}$ [mm]	Tension load			Shear load		
		$F_{Rk}$ <sup>2)</sup> [kN]	$\delta_{N0}$ [mm]	$\delta_{N\infty}$ [mm]	$F_{Rk}$ <sup>2)</sup> [kN]	$\delta_{V0}$ [mm]	$\delta_{V\infty}$ [mm]
<b>ZEBRA Shark W-ZX 8</b>	$\geq 45$	0.6	0.03	0.06	0.6	1.71	2.57
<b>ZEBRA Shark W-ZX 10</b>	$\geq 55$	1.4	0.10	0.20	1.4	3.12	4.69

1) Valid for all ranges of temperatures

2) Intermediate values by linear interpolation

**Table 7: Minimum thickness of member, edge distance and anchor spacing in concrete**

**ZEBRA Shark W-ZX 8:** Fixing points with a spacing  $s_{cr,N} \leq 40$  mm are considered as a group with a max. characteristic resistance  $N_{Rk,p}$  acc. to Table 5. For  $s_{cr,N} > 40$  mm, the anchors are considered as single anchors, each with a characteristic resistance  $N_{Rk,p}$  acc. to Table 5

**ZEBRA Shark W-ZX 10:** Fixing points with a spacing  $s_{cr,N} \leq 80$  mm are considered as a group with a max. characteristic resistance  $N_{Rk,p}$  acc. to Table 5. For  $s_{cr,N} > 80$  mm, the anchors are considered as single anchors, each with a characteristic resistance  $N_{Rk,p}$  acc. to Table 5

		$h_{nom}$ [mm]	$h_{min}$ [mm]	$c_{cr,N}$ [mm]	$c_{min}$ [mm]	$s_{min}$ [mm]
<b>ZEBRA W-ZX 8</b>	Concrete $\geq$ C16/20	$\geq 45$	100	80	80	80
	Concrete C12/15	$\geq 45$	100	120	110	110
<b>ZEBRA W-ZX 10</b>	Concrete $\geq$ C16/20	$\geq 55$	100	80	80	80
	Concrete C12/15	$\geq 55$	100	120	110	110

Concrete:  
(Table 7)

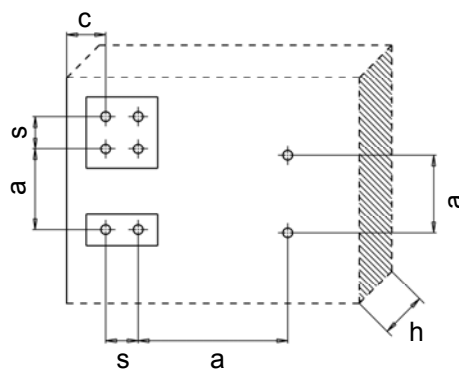

Würth plastic anchor ZEBRA Shark W-ZX 8 and ZEBRA Shark W-ZX 10

Displacements;  
Minimum thickness of member, edge distance and anchor spacing

Annex 6