

European Technical Approval ETA-05/0090

English translation prepared by DIBt - Original version in German language

Handelsbezeichnung
Trade name

DURISOL - Schalungssteine aus Holzspanbeton
DURISOL - shuttering blocks made of wood-chip concrete

Zulassungsinhaber
Holder of approval

Durisol-Werke GesmbH
Nachfg. Kommanditgesellschaft
Durisolstrasse 1
2481 Achau
ÖSTERREICH

Zulassungsgegenstand
und Verwendungszweck
*Generic type and use
of construction product*

Nicht lasttragendes verlorenes Schalungssystem "DURISOL"
bestehend aus Schalungssteinen aus Holzspanbeton
*Non-load bearing permanent shuttering kit "DURISOL" based on
shuttering blocks of wood-chip concrete*

Geltungsdauer:
Validity: vom
from
bis
to

15 May 2013
15 May 2018

Herstellwerk
Manufacturing plant

D1
D2
D3

Diese Zulassung umfasst
This Approval contains

30 Seiten einschließlich 10 Anhänge
30 pages including 10 annexes

Diese Zulassung ersetzt
This Approval replaces

ETA-05/0090 mit Geltungsdauer vom 14.12.2010 bis 14.12.2015
ETA-05/0090 with validity from 14.12.2010 to 14.12.2015

I LEGAL BASES AND GENERAL CONDITIONS

- 1 This European technical approval is issued by Deutsches Institut für Bautechnik in accordance with:
 - Council Directive 89/106/EEC of 21 December 1988 on the approximation of laws, regulations and administrative provisions of Member States relating to construction products¹, modified by Council Directive 93/68/EEC² and Regulation (EC) N° 1882/2003 of the European Parliament and of the Council³;
 - *Gesetz über das In-Verkehr-Bringen von und den freien Warenverkehr mit Bauprodukten zur Umsetzung der Richtlinie 89/106/EWG des Rates vom 21. Dezember 1988 zur Angleichung der Rechts- und Verwaltungsvorschriften der Mitgliedstaaten über Bauprodukte und anderer Rechtsakte der Europäischen Gemeinschaften (Bauproduktengesetz - BauPG) vom 28. April 1998⁴, as amended by Article 2 of the law of 8 November 2011⁵;*
 - Common Procedural Rules for Requesting, Preparing and the Granting of European technical approvals set out in the Annex to Commission Decision 94/23/EC⁶;
 - Guideline for European technical approval of "Nonload-bearing permanent shuttering systems based on hollow blocks or panels of insulating materials and sometimes concrete", ETAG 009.
- 2 Deutsches Institut für Bautechnik is authorized to check whether the provisions of this European technical approval are met. Checking may take place in the manufacturing plant. Nevertheless, the responsibility for the conformity of the products to the European technical approval and for their fitness for the intended use remains with the holder of the European technical approval.
- 3 This European technical approval is not to be transferred to manufacturers or agents of manufacturers other than those indicated on page 1, or manufacturing plants other than those indicated on page 1 of this European technical approval.
- 4 This European technical approval may be withdrawn by Deutsches Institut für Bautechnik, in particular pursuant to information by the Commission according to Article 5(1) of Council Directive 89/106/EEC.
- 5 Reproduction of this European technical approval including transmission by electronic means shall be in full. However, partial reproduction can be made with the written consent of Deutsches Institut für Bautechnik. In this case partial reproduction has to be designated as such. Texts and drawings of advertising brochures shall not contradict or misuse the European technical approval.
- 6 The European technical approval is issued by the approval body in its official language. This version corresponds fully to the version circulated within EOTA. Translations into other languages have to be designated as such.

¹ Official Journal of the European Communities L 40, 11 February 1989, p. 12
² Official Journal of the European Communities L 220, 30 August 1993, p. 1
³ Official Journal of the European Union L 284, 31 October 2003, p. 25
⁴ *Bundesgesetzblatt Teil I 1998*, p. 812
⁵ *Bundesgesetzblatt Teil I 2011*, p. 2178
⁶ Official Journal of the European Communities L 17, 20 January 1994, p. 34

II SPECIFIC CONDITIONS OF THE EUROPEAN TECHNICAL APPROVAL

1 Definition of the product and intended use

1.1 Definition of the construction product

1.1.1 General

The shuttering system "DURISOL" is a non load-bearing permanent shuttering kit based on standard shuttering blocks and special shuttering blocks (see Annexes 1 and 2) applicable as formwork for plain and reinforced concrete walls cast in-situ.

The shuttering blocks consist of shuttering leaves and webs of wood-chip concrete.

The shuttering blocks are generally used for external load-bearing walls as well as for internal load-bearing walls.

Finishes are not part of the shuttering system "DURISOL".

1.1.2 Standard shuttering blocks

The standard shuttering blocks (see Annex 1) consist of inner and outer shuttering leaves and webs of mineral bonded wood-chips (wood-chip concrete) according to EN 14474. The wood-chip concrete standard shuttering blocks are precast concrete products and may include factory installed thermal insulation (see clause 2.1.2, Table 1) according to the relevant standard of the series EN 13162 to EN 13171 to improve the thermal resistance.

The shuttering leaves of wood-chip concrete are one-layered and the webs of wood-chip concrete provide thicknesses of the concrete columns in the range of 90 mm to 200 mm and thicknesses of the wall in the range of 150 mm to 375 mm, as indicated in Annex 1. The thickness of the inner shuttering leaves is in the range of 25 mm to 45 mm and the thickness of the outer shuttering leaves is in the range of 25 mm to 90 mm. Standard shuttering blocks with the same thickness of the inner and outer shuttering leaf are also used for internal walls. Standard shuttering blocks with a thicker outer shuttering leaf or with thermal insulation inserts are generally used for external load-bearing walls. The thickness of the thermal insulation inserts is in the range of 60 mm to 175 mm (see Annex 1). The length of the standard shuttering blocks is 498 mm and the height is 250 mm (see Annex 1).

The vertical ends of the standard shuttering blocks are either smooth or tongue and groove joints depending on the type of standard shuttering blocks and form a tight joint. The top and the bottom of each shuttering leaf do not provide an interlocking arrangement to form a tight joint but the static friction between the top and the bottom surfaces ensure an adequate positional stability when building up the standard shuttering blocks and while placing the concrete.

The standard shuttering blocks are dry laid in staggered vertical joints (masonry bond).

The standard shuttering blocks are interlocked and built up horizontally and vertically into a tight and rigid formwork. The wall is formed by filling of the standard shuttering blocks with concrete. The formwork is used in conjunction with concrete class C16/20 (according to EN 206-1) to build plain concrete walls or in conjunction with concrete of classes in the range from C20/25 to C50/60 (according to EN 206-1) to build reinforced concrete walls.

The shuttering system "DURISOL" provide shuttering elements (panels) generally of one storey height by pre-assembling the wood-chip concrete standard shuttering blocks with adhesive. The length of these panels is maximum 6 m and the height is maximum 3,50 m (see Annexes 5 to 7).

1.1.3 Special shuttering blocks

The special shuttering blocks are specially shaped ancillary blocks for the execution of constructional details, such as corners, reveals, lintels, etc.

1.1.3.1 Stopper blocks / Corner blocks / Universal blocks (Annex 2)

Stopper blocks respectively corner blocks respectively universal blocks are designed in the same manner as the standard shuttering blocks described above, see clause 1.1.2.

1.1.3.2 Lintel blocks

Lintel blocks are made of standard shuttering blocks (see clause 1.1.2) by cutting out all inner webs and one of the end webs of these shuttering blocks. The maximum height of the shuttering leaf of the lintel blocks shall not exceed 0,75 m.

1.2 Intended use

The kit is intended to be used for the construction of internal walls as well as external walls above or below ground which are load-bearing (structural) or non load-bearing (non structural), including those which are subjected to fire regulations.

When using this type of construction below ground a waterproofing according to applicable national rules shall be provided depending on whether non pressing water or pressing water is to be dealt with. The waterproofing shall be protected from mechanical damage by an impact resistant protective layer.

Furthermore the kit could be used for constructions outside of buildings as free-standing walls like garden walls, noise-insulating walls etc.

According to EOTA TR 034 the following use categories apply:

- Category IA 2: Product with no direct contact to (e. g. covered products) but possible impact on indoor air.
- Category S/W 3: Product with no contact to and no impact on soil water, ground- and surface water.

The provisions made in this European technical approval are based on an assumed working life of the shuttering kit of at least 50 years, provided that the conditions laid down in clauses 4.2, 5.1 and 5.2 for the packaging, transport, storage, installation, use, maintenance and repair are met. The indications given on the working life cannot be interpreted as a guarantee given by the manufacturer, but are to be regarded only as a means for choosing the right products in relation to the expected economically reasonable working life of the works.

For the intended use it is essential to protect this type of construction against effects of weather.

2 Characteristics of product and methods of verification

2.1 Characteristics of product

2.1.1 General

The shuttering kit "DURISOL" consists of the following shuttering blocks:

- standard shuttering blocks and
- special shuttering blocks,

see clauses 2.1.2 and 2.1.3.

2.1.2 Standard shuttering blocks

The standard shuttering blocks (composed of shuttering leaves and webs of wood-chip concrete) correspond to the information and drawings given in Annex 1.

The geometric characteristics of the standard shuttering blocks are given in Annexes 1 and 4. The requirements of the standard shuttering blocks regarding to geometric characteristics are given in EN 15498, clauses 4.2.1 and 5.2.1.

Only wood-chip concrete according to EN 14474 shall be used for the manufacture of shuttering blocks of wood-chip concrete.

The material oven dry density ρ_{dry} of wood-chip concrete of the standard shuttering blocks is

- 550 kg/m³ (see Annex 4),
- 600 kg/m³ (see Annex 4) and
- 810 kg/m³ (see Annex 4).

The mean material oven dry density shall deviate by not more than $\pm 10\%$ from the declared value according to EN 15498, clauses 4.2.2 and 5.2.2.

The minimum value of tensile strength of the webs $f_{t,m}$ of wood-chip concrete according to EN 15498, clauses 4.2.6 and 5.2.6 shall be at least the value determined according to EN 15498, Annex B, clause B.4.2.

When thermal insulation inserts are used (see Annex 1), they shall comply with the relevant standard of the series EN 13162 to EN 13171. The materials of the thermal insulation inserts are:

- mineral wool,
- expanded polystyrene,
- extruded polystyrene foam,
- polyurethane foam,
- expanded cork and
- wood fibre.

The parameters and characteristics of the thermal insulation inserts are indicated in Table 1.

Table 1: Parameters and characteristics of the thermal insulation inserts

Thermal insulation inserts	Standard	Designation code of the thermal insulation inserts (see Annex 1)	Mean value of density	Declared value of thermal conductivity	Reaction to fire: Class according to EN 13501-1 see clause 2.2.3.1	
			ρ	λ_D	thermal insulation inserts	shuttering blocks with thermal insulation inserts
			[kg/m ³]	[W/(m×K)]		
Mineral wool (MW)	EN 13162	MW-EN 13162-T5-CS(10)50-TR7,5-PL(5)500-WS-WL(P)-MU1	22,0	0,039	A1	B-s1, d0
		MW-EN 13162-T5-DS(T+)-CS(10)70-TR15-PL(5)600-WS-WL(P)-MU1	22,0	0,039	A1	B-s1, d0
Expanded polystyrene (EPS)	EN 13163	EPS-EN 13163-T2-L2-W2-S2-P4-DS(70,-)1-BS115-CS(10)70 - DS(N)2-TR100	15,0	0,031	E	B-s1, d0
Extruded polystyrene foam (XPS)	EN 13164	XPS-EN 13164-T1-CS(10/Y)300-DS(TH)-DLT(2)5-CC(2/1,5/50)130-WD(V)3-FT2 thickness 70 – 120 mm	30,0	0,036	E	E
Polyurethane foam (PUR)	EN 13165	PUR-EN 13165-T2-DS(TH)9-CS(10\Y)150-TR40	30,0	0,028	E	E
			30,0	0,023	D-s2, d0	D-s2, d0
		PUR-EN 13165-T2-DS(TH)9-CS(10\Y)150-TR100	30,0	0,028	E	E
			30,0	0,027	C-s3, d0	C-s3, d0
PUR-EN 13165-T2-DS(TH)9-CS(10\Y)100-TR100	30,0	0,027	E	E		
Expanded cork (ICB)	EN 13170	ICB-EN 13170-L2-W2-T1-CS(10)100-TR50-WS thickness 20 – 50 mm	100	0,040	E	E
		ICB-EN 13170-L2-W2-T2-CS(10)100-TR50-WS thickness > 50 mm				
Wood fibre (WF)	EN 13171	WF-EN 13171-T2-TR2,5-MU3-AF5	55,0	0,038	E	E

The material characteristics, dimensions and tolerances of the standard shuttering blocks not indicated in Annexes 1 and 4 are given in the technical documentation⁷ of the ETA.

⁷

The technical documentation of the ETA is deposited at DIBt and, as far as relevant for the tasks of the approved bodies involved in the attestation of conformity procedure, is handed over to the approved bodies.

2.1.3 Special shuttering blocks

The special shuttering blocks correspond to the information and drawings given in Annex 2. The special shuttering blocks are:

- stopper blocks / corner blocks / universal blocks and
- lintel blocks.

Special shuttering blocks are designed in the same manner as the standard shuttering blocks described above, see clause 1.1.2.

The special shuttering blocks consist of shuttering leaves and webs of mineral bonded wood-chips (wood-chip concrete) and may include factory installed thermal insulation, it is the same material used for standard shuttering blocks specified in clause 2.1.2.

2.2 Methods of verification

2.2.1 General

The assessment of the fitness of the shuttering system for the intended use has been made in compliance with ETAG 009, Guideline for European technical approval of "Non load-bearing permanent shuttering kits/systems based on hollow blocks or panels of insulating materials and sometimes concrete", edition June 2002.

The ETA is issued for the shuttering kit "DURISOL" on the basis of agreed information, deposited with Deutsches Institut für Bautechnik (DIBt), which identifies the shuttering kit that has been assessed and evaluated. Changes to the production process, the kit or the components which could result in this deposited information being incorrect, shall be notified to DIBt before the changes are introduced. DIBt will decide whether or not such changes affect the ETA and consequently the validity of the CE marking on the basis of the ETA, and, if so, whether further assessment and/or alterations to the ETA shall be necessary.

2.2.2 Essential Requirement 1: Mechanical resistance and stability

2.2.2.1 Resulting structural pattern

In end use conditions walls made with shuttering blocks "DURISOL" are walls of a grid type according to ETAG 009, clause 2.2.

2.2.2.2 Efficiency of filling

Considering the instructions of clause 4.2 and the installation guide of the manufacturer an efficient filling without bursting of the shuttering and without voids or any uncovered reinforcement in the concrete columns is possible.

The requirements according to ETAG 009, clause 6.1.2 are met satisfactorily.

2.2.2.3 Possibility of steel reinforcement

The instructions according to clause 4.2.2 and in the installation guide of the manufacturer are appropriate to install steel reinforcement for walls according to EN 1992-1-1 or corresponding national rules.

The requirements according to ETAG 009, clause 6.1.3 are met satisfactorily.

2.2.3 Essential Requirement 2: Safety in case of fire

2.2.3.1 Reaction to fire⁸

Shuttering blocks "DURISOL" made of wood-chip concrete indicated with * in Annexes 1 and 2 (shuttering blocks **without** thermal insulation inserts) fulfil the requirement of Class A2-s1, d0 according to EN 13501-1.

Shuttering blocks "DURISOL" made of wood-chip concrete not indicated with * in Annexes 1 and 2 (shuttering blocks **with** thermal insulation inserts) fulfil the requirements of classification criteria of Table 1 according to EN 13501-1.

2.2.3.2 Resistance to fire

The walls will be exposed to fire on one site only.

According to ETAG 009, Annex C, Table 1, for grid type walls of load-bearing walls ("REI") and a minimum concrete strength of C16/20, the system meets the criteria "REI" according to Table 2.

Table 2: Determination of "REI" of load-bearing walls

Minimum dimension of concrete columns [mm]	"REI"
100	30
120	60
150	90
170	120

The preconditions for this classification are:

- The design of the building has to take into consideration the secondary effects of fire. Especially constraints, introduced by thermal strain, should be sufficiently low and appropriate building joints should be foreseen. The rules, valid in place of use, govern. Structural requirements on work in normal conditions, valid in the place of use, may require larger dimensions. Concrete cover for the reinforcement has to be observed according to the rules valid in the place of use.
- A normal weight concrete as defined in EN 206-1 or EN 1992-1-1 shall be used. As far as European standards EN 206-1 or EN 1992-1-1 are not in force, an equivalent concrete according to national rules, valid in the place of use, is acceptable. The strength class of concrete shall be between C16/20 and C50/60 according to EN 206-1. In lack of availability of European standard EN 206-1, alternatively a concrete according to national rules, valid in the place of use, with a compressive strength which fits in the interval given above, is also considered as appropriate.
- The shuttering blocks shall on both sides either be plastered/rendered or at least the joints on both sides shall be sealed with plastering/rendering mortar. The mortar for plastering/rendering or for sealing shall be based on inorganic aggregates, gypsum, cement or lime or on suitable combinations of these three binders.

Note: The classification of walls constructed with the shuttering system "DURISOL" regarding to fire resistance are valid only for walls without openings (for windows or doors for examples).

⁸ A European reference fire scenario for facades has not been laid down. In some Member States the classification of permanent shuttering systems according to EN 13501-1 might not be sufficient for the use in facades. An additional assessment of permanent shuttering systems according to national provisions (e.g. on the basis of a large scale test) might necessary to comply with Member States regulations, until the existing European classification system has been completed.

2.2.4 Essential Requirement 3: Hygiene, health and environment

2.2.4.1 Content and/or release of dangerous substances

The chemical composition of the shuttering system/kit must comply with the data deposited with DIBt.⁹

Due to the chemical composition of the shuttering system "DURISOL", the product does not contain dangerous substances according to Council Directive 67/548/EEC, Regulation (EC) No 1272/2008 and/or the "Indicative list on dangerous substances" of the EGDS (expert group on dangerous substances of the European Commission) with the exception of hexabromocyclododecane (HBCDD).

The content of HBCDD is < 1 % by weight.

Note: For dangerous substances falling under the scope of the CPD for which:

- no assessment and verification methods are given in this ETA,

or

- the "No performance determined" option is declared,

or

- the chosen verification and assessment method does not comply with the regulatory requirement of a particular Member State,

there might be the necessity for an additional assessment at national level.

2.2.4.2 Water vapour permeability

The values of the water vapour resistance factor of wood-chip concrete are $\mu = 2$ (wet conditions) respectively $\mu = 8$ (dry conditions).

The values of the water vapour resistance factor of concrete columns depending on type and density and of the materials of thermal insulation inserts (see clause 2.1.2, Table 1) are tabulated values in EN ISO 10456.

Using these values the verification of the annual moisture balance or the maximum amount of interstitial condensation according to EN ISO 13788 will be on the safe side.

2.2.4.3 Water absorption

The requirements according to ETAG 009, clause 6.3.3 are met satisfactorily.

2.2.4.4 Watertightness

Because finishes are not part of the shuttering system "DURISOL" the "No performance determined" option in ETAG 009, Table 3 is used.

2.2.5 Essential Requirement 4: Safety in use

2.2.5.1 Bond strength between shuttering leaves of wood-chip concrete and concrete columns and resistance to impact load

The bond strength is at least equal to the resistance of the shuttering blocks against the pressure of fresh concrete, see clause 2.2.5.2.

Concrete walls (without consideration of the finishes), constructed with shuttering system "DURISOL" and designed according EN 1992-1-1 respectively in lack of availability of EN 1992-1-1 according national design rules, lead to the assumption that concrete columns insures an adequate resistance of the complete wall under normal used impact loads.

The requirements according to ETAG 009, clause 6.4.1 are met satisfactorily.

⁹

In addition to the specific clauses relating to dangerous substances contained in this European technical approval, there may be other requirements applicable to the products falling within its scope (e.g. transposed European legislation and national laws, regulations and administrative provisions). In order to meet the provisions of the Construction Products Directive, these requirements need also to be complied with, when and where they apply.

2.2.5.2 Resistance to pressure of fresh concrete

To resist the pressure of fresh concrete according to EN 15498, Annex A the minimum value of tensile strength of the webs $f_{t,m}$ of wood-chip concrete and the minimum value of bending tensile strength of the shuttering leaves $f_{f,m}$ of wood-chip concrete according to EN 15498, clauses 4.2.6 and 5.2.6 shall be at least the values determined according to EN 15498, Annex B, clause B.4.2 and Annex C, clause C.4.2. The minimum value of tensile strength of the shuttering leaves of wood-chip concrete perpendicular to faces $f_{t,p}$ shall be at least 0,15 MPa.

The requirements according to ETAG 009, clause 6.4.2 are met satisfactorily.

2.2.5.3 Safety against personal injury by contact

Delivered on site the shuttering blocks do not have sharp or cutting edges.

Because of a certain risk of abrasion or of cutting people on rough surfaces of the shuttering blocks handling on site shall be done with gloves.

2.2.6 Essential Requirement 5: Protection against noise

2.2.6.1 Airborne sound insulation

The "No performance determined" option in ETAG 009, Table 3 is used.

2.2.6.2 Sound absorption

The "No performance determined" option in ETAG 009, Table 3 is used.

2.2.7 Essential Requirement 6: Energy economy and heat retention

2.2.7.1 Thermal resistance

The declared value of thermal resistance $R_{D,wall}$ of walls made of shuttering blocks of wood-chip concrete in end use conditions (shuttering blocks with concrete columns and maybe thermal insulation inserts but without rendering) is the sum of the declared value of thermal resistance of the shuttering blocks of wood-chip concrete $R_{D,block}$, the concrete columns $R_{D,concrete}$ and maybe the thermal insulation inserts $R_{D,insulation}$. The declared value of thermal resistance of the shuttering blocks of wood-chip concrete $R_{D,block}$ shall be calculated in accordance with EN ISO 6946 with a declared value of thermal conductivity λ_D of the shuttering blocks of wood-chip concrete depending on the material oven dry density ρ_{dry} tabulated in Table 3. The declared value of thermal resistance of the concrete columns $R_{D,concrete}$ shall be calculated in accordance with EN ISO 6946 with a value of thermal conductivity λ of the concrete columns depending on the density ρ tabulated in EN ISO 10456. The declared value of thermal resistance of thermal insulation inserts $R_{D,insulation}$ shall be calculated in accordance with EN ISO 6946 with a declared value of thermal conductivity λ_D of the materials of thermal insulation inserts tabulated in Table 1.

Table 3: Declared value of thermal conductivity of wood-chip concrete

Material oven dry density ρ_{dry} [kg/m ³]	Declared value of thermal conductivity λ_D [W/(m × K)]
550	0,130
600	0,150
810	0,240

Walls made of shuttering blocks consisting of thermally homogenous and thermally inhomogeneous layers according to EN ISO 6946. The declared value of thermal resistance $R_{D,wall}$ of walls made of shuttering blocks of wood-chip concrete in end use conditions (shuttering blocks with concrete columns and maybe thermal insulation inserts but without rendering) shall be calculated according to the three following methods:

- Determination of the wall as three thermally homogeneous layers according to EN ISO 6946, clause 6.1 without considering the webs:
 - inner shuttering leaf of wood-chip concrete,
 - concrete column and
 - outer shuttering leaf of wood-chip concrete.

This calculation leads to the minimum declared value of thermal resistance $R_{D,wall}$ of walls made of shuttering blocks of wood-chip concrete.

- Determination of the wall as thermally homogenous and thermally inhomogeneous layers parallel to the surface of the wall according to EN ISO 6946, clause 6.2. For a simplified calculation it is possible to replace the real semicircular horizontal concrete ribs A_R (web recess areas) between the chambers of the concrete columns by modelled rectangular areas A_R , see the following Figure 1.

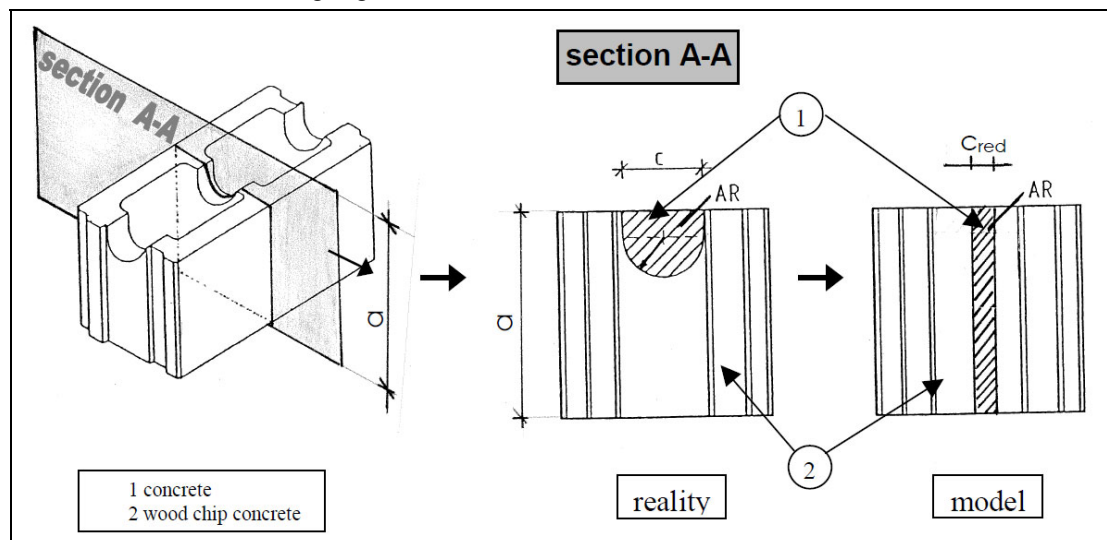

Figure 1: Replacing of the real semicircular horizontal concrete ribs A_R (web recess areas) between the chambers of the concrete columns by modelled rectangular areas A_R

- Determination by calculation methods according to EN ISO 10211.

In case of shuttering blocks with thermal insulation inserts (see Annexes 1 and 2), the second or the third method has to be used.

2.2.7.2 Influence of moisture transfer on insulating capacity of the wall

Using the values of clause 2.2.4.2 the verification of the annual moisture balance or the maximum amount of interstitial condensation according to EN ISO 13788 will be on the safe side.

2.2.7.3 Heat capacity

The value of the heat capacity c of the shuttering blocks of wood-chip concrete is $c = 1,50 \text{ kJ}/(\text{kg} \times \text{K})$ according to EN 15498, clause 5.2.8.2.

The values of the heat capacity c of the concrete columns and of the materials of thermal insulation inserts (see clause 2.1.2, Table 1) are tabulated values in EN ISO 10456.

2.2.8 Aspects of durability and serviceability

2.2.8.1 Resistance to deterioration

Physical agent

Since the thermal expansion coefficient of wood-chip concrete is not higher than of normal weight concrete the relative changes of the shuttering blocks in length, width and thickness under specified temperature and humidity conditions shall not exceed 0,07 % after exposing them for 48 h at 70 °C.

The requirements according to ETAG 009, clause 6.7.1.1 are met satisfactorily.

Chemical agent

The shuttering blocks are made of wood-chip concrete. There is no corrosion of the wood-chip concrete webs in concrete.

The finishes of the wall are not part of the ETA. Determination of the cleaning agent of the surface is not possible.

The requirements according to ETAG 009, clause 6.7.1.2 are met satisfactorily.

Biological agent

The application of wood-chip concrete as thermal insulation material for decades has shown that it is sufficiently protected against fungi, bacteria, algae and insects.

Wood-chip concrete and the thermal insulation inserts do not provide a food value and in general it does not contain voids suitable for habitation by vermin.

The shuttering system "DURISOL" does not contain any biocides.

The requirements according to ETAG 009, clause 6.7.1.3 are met satisfactorily.

2.2.8.2 Resistance to normal use damage

Normal use impacts

Concrete walls (without consideration of the finishes), constructed with shuttering system "DURISOL" and designed according EN 1992-1-1 respectively in lack of availability of EN 1992-1-1 according national design rules, lead to the assumption that concrete columns insures an adequate resistance of the complete wall under normal used impact loads.

The requirements according to ETAG 009, clause 6.7.2.1 are met satisfactorily.

Incorporation of ducts

The instructions in the installation guide of the manufacturer are appropriate to produce horizontal perforations through the walls, which are necessary for passing through ducts, see clause 4.2.4.

The requirements according to ETAG 009, clause 6.7.2.2 are met satisfactorily.

Fixing of objects

Fixing of objects in the shuttering leaves of wood-chip concrete is not possible. The part of fixings which is significant for the mechanical resistance shall be inside the concrete columns.

The requirements according to ETAG 009, clause 6.7.2.3 are met satisfactorily.

3 Evaluation and attestation of conformity and CE marking

3.1 System of attestation of conformity

According to the Decision 98/279/EC of 5 December 1997¹⁰ amended by the Decision 2001/596/EC¹¹ of the European Commission system 2+ of the attestation of conformity applies.

This system of attestation of conformity is defined as follows:

System 2+: Declaration of conformity of the product by the manufacturer on the basis of:

- (a) Tasks for the manufacturer:
 - (1) initial type-testing of the product;
 - (2) factory production control;
 - (3) testing of samples taken at the factory in accordance with a prescribed control plan.
- (b) Tasks for the approved body:
 - (4) certification of factory production control on the basis of:
 - initial inspection of factory and of factory production control;
 - continuous surveillance, assessment and approval of factory production control.

In addition, according to the Decision 2001/596/EC¹² of the European Commission system 1 of the attestation of conformity applies with regard to reaction to fire.

This system of attestation of conformity is defined as follows:

System 1: Certification of the conformity of the product by an approved certification body on the basis of:

- (a) Tasks for the manufacturer:
 - (1) factory production control;
 - (2) further testing of samples taken at the factory by the manufacturer in accordance with a prescribed control plan;
- (b) Tasks for the approved body:
 - (3) initial type-testing of the product;
 - (4) initial inspection of factory and of factory production control;
 - (5) continuous surveillance, assessment and approval of factory production control.

Note: Approved bodies are also referred to as "notified bodies".

3.2 Responsibilities

3.2.1 Tasks for the manufacturer

3.2.1.1 Initial type-testing of the product

For initial type-testing the results of the tests performed as part of the assessment for the European technical approval may be used unless there are changes to the product, in the production line or plant. In such cases the necessary initial type-testing shall be agreed between DIBt and the manufacturer involved.

¹⁰ Official Journal of the European Communities L 127 of 24 April 1998
¹¹ Official Journal of the European Communities L 209 of 8 January 2001
¹² Official Journal of the European Communities L 209/33 of 2 August 2001

3.2.1.2 Factory production control

The manufacturer shall exercise permanent internal control of production. All the elements, requirements and provisions adopted by the manufacturer shall be documented in a systematic manner in the form of written policies and procedures, including records of results performed. This production control system shall insure that the product is in conformity with this European technical approval.

The manufacturer may only use raw materials stated in the technical documentation of this European technical approval.

The factory production control shall be in accordance with the modified control plan of 15 May 2013 which is part of the technical documentation of this European technical approval. The control plan is laid down in the context of the factory production control system operated by the manufacturer and deposited with Deutsches Institut für Bautechnik.¹³

The results of factory production control shall be recorded and evaluated in accordance with the provisions of the control plan.

3.2.1.3 Other tasks of the manufacturer

The manufacturer shall, on the basis of a contract, involve a body which is approved for the tasks referred to in clause 3.1 in the field of non load-bearing shuttering systems in order to undertake the actions laid down in clause 3.2.2. For this purpose, the control plan referred to in clauses 3.2.1.2 and 3.2.2 shall be handed over by the manufacturer to the approved body involved.

The manufacturer shall make a declaration of conformity, stating that the construction product is in conformity with the provisions of this European technical approval.

3.2.2 Tasks for the approved body

The approved body shall perform the

- initial type-testing of the product (only for reaction to fire),
- initial inspection of factory and of factory production control and
- continuous surveillance, assessment and approval of factory production control

in accordance with the provisions laid down in the control plan.

The frequency of the inspections by the approved bodies shall be performed in accordance with section II of control plan.

The approved body shall retain the essential points of its actions referred to above and state the results obtained and conclusions drawn in a written report.

The approved certification body involved by the manufacturer shall issue an EC certificate of conformity of the product stating the conformity with the provisions of this European technical approval (only for reaction to fire).

The approved certification body involved by the manufacturer shall issue an EC certificate of conformity of the factory production control stating the conformity with the provisions of this European technical approval.

In cases where the provisions of the European technical approval and its control plan are no longer fulfilled the certification body shall withdraw the certificate of conformity and inform Deutsches Institut für Bautechnik without delay.

¹³ The control plan is a confidential part of the European technical approval and only handed over to the approved body involved in the procedure of attestation of conformity. See clause 3.2.2.

3.3 CE marking

The CE marking shall always be affixed on packaging and on the accompanying commercial documents. The letters "CE" shall be followed by the identification number of the approved certification body and be accompanied by the following additional information.

3.3.1 CE marking on packaging of the product

- the name and the address of the manufacturer (legal entity responsible for the manufacturer)
- the last two digits of the year in which the CE marking was affixed
- the number of the EC certificate of conformity for the product (only for reaction to fire)
- the number of the EC certificate for the factory production control
- the number of the European technical approval ETA-05/0090
- the number of the guideline ETAG 009 of the European technical approval
- description of the product: generic name

3.3.2 CE marking on the accompanying commercial documents of the product

- the name and the address of the manufacturer (legal entity responsible for the manufacturer)
- the last two digits of the year in which the CE marking was affixed
- the number of the EC certificate of conformity for the product (only for reaction to fire)
- the number of the EC certificate for the factory production control
- the number of the European technical approval ETA-05/0090
- the number of the guideline ETAG 009 of the European technical approval
- description of the product: generic name, material, dimensions, ... and intended use
- information on those relevant essential characteristics which are to be declared presented as declared values and, where relevant, level or class according to Essential Requirements or "No performance determined" for characteristics where this is relevant according to Essential Requirements
 - Geometric characteristics of the standard shuttering blocks (see clause 2.1.2 and Annexes 1 and 4)
 - Designation code of the thermal insulation inserts (see clause 2.1.2, Table 1)
 - Reaction to fire: Class according to EN 13501-1 (see clause 2.2.3.1)
 - Resistance to fire: Class according to EN 13501-2 in dependence of minimum dimension of the concrete columns (see clause 2.2.3.2)
 - Water vapour permeability (see clause 2.2.4.2)
 - Minimum value of tensile strength of the webs $f_{t,m}$ of wood-chip concrete (see clause 2.2.5.2)
 - Minimum value of bending tensile strength of the shuttering leaves $f_{t,m}$ of wood-chip concrete (see clause 2.2.5.2)
 - Minimum value of tensile strength of the shuttering leaves of wood-chip concrete perpendicular to faces f_{tp} (see clause 2.2.5.2)
 - Protection against noise (see clause 2.2.6)
 - Declared value of thermal conductivity λ_D of the shuttering blocks of wood-chip concrete depending on the material oven dry density ρ_{dry} (see clause 2.2.7.1, Table 3) and maybe the declared value of thermal conductivity λ_D of the materials of thermal insulation inserts (see clause 2.1.2, Table 1)

4 Assumptions under which the fitness of the product for the intended use was favourably assessed

4.1 Manufacturing

The shuttering blocks are manufactured in accordance with the provisions of the European technical approval using the automated manufacturing process as identified during the inspection of the plant by Deutsches Institut für Bautechnik (DIBt) and the approved body and laid down in the technical documentation.

The European technical approval is issued for the product on the basis of agreed data/information, deposited with Deutsches Institut für Bautechnik, which identifies the product that has been assessed and judged. Changes to the product or production process, which could result in this deposited data/information being incorrect, should be notified to Deutsches Institut für Bautechnik before the changes are introduced. Deutsches Institut für Bautechnik will decide whether or not such changes affect the approval and consequently the validity of the CE marking on the basis of the approval and if so whether further assessment or alterations to the approval shall be necessary.

4.2 Installation

4.2.1 General

The manufacturer shall ensure that the requirements in accordance with clauses 1, 2, and 4 are made known to those involved in planning and execution. The installation guide is deposited with Deutsches Institut für Bautechnik and shall be present at every construction site. If the manufacturer's instructions contain provisions which differ from those stated here, the specifications of the ETA shall apply.

After installation of the shuttering blocks (see clause 4.2.2) site mixed or ready mixed concrete is placed and compacted (see clause 4.2.3).

In end use conditions concrete walls of a grid type¹⁴ of plain or reinforced concrete will be formed according to EN 1992-1-1 or according to corresponding national rules.

For structural design purposes the dimensions, volumes and weights of the wall depending on type of shuttering blocks and on material oven dry density ρ_{dry} of the wood-chip concrete are shown in Annex 4.

In end use conditions the shuttering leaves of wood-chip concrete and the thermal insulation inserts are the main part of the thermal insulation of the walls.

The design values of thermal resistance respectively the design values of thermal conductivity shall be laid down according to the relevant national provisions.

4.2.2 Installation of the shuttering blocks

The shuttering blocks are put together on site in layers without mortar or adhesive. To receive stable floor high formworks the vertical joints between two shuttering blocks of one layer have to be shifted of at least a quarter of the block length, better a half of the block length, to the vertical joints of the previous and next layer (see Annex 3).

First of all one layer of the entire floor plan shall be laid exactly according to the planned elevation and alignment according to the installation guide of the manufacturer.

Afterwards levelling to the subsoil is performed (foundation, bottom, ground floor and ceiling). Voids between the shuttering leaves and the uneven subsoil are to be sealed with PU foam before concreting.

¹⁴ see ETAG 009, clause 2.2

Subsequently, according to the installation guide of the manufacturer, the shuttering blocks are to be laid in a bond formation (see Annex 3) to floor height and levelled.

The formwork is used in conjunction with concrete class C16/20 (according to EN 206-1) to build plain concrete walls or in conjunction with concrete of classes in the range from C20/25 to C50/60 (according to EN 206-1) to build reinforced concrete walls. The following instructions are appropriate to install steel reinforcement for walls according to EN 1992-1-1 or corresponding national rules:

- Horizontal reinforcement: In every horizontal concrete rib (web recess area).
- Vertical reinforcement: A single reinforcing bar or a reinforcing wire-mesh or a reinforcement cage in every column.

The preconditions to install steel reinforcement are:

- Vertical reinforcement: The dimensions of reinforcing wire-meshes or reinforcement cages including bar spacers shall be appropriate to the corresponding minimum dimensions of the concrete columns. If more than one reinforcing bar is installed all reinforcing bars shall be connected with each other by welded on or wired cross bars to a mesh.
- Planning shall allow for sufficient spaces in the reinforcement for discharge pipes or concreting tubes.
- The resistance of the wood-chip concrete to carbonation and chloride penetration is not determined, i. e. the concrete cover according to EN 1992-1-1 or corresponding national rules shall apply.
- The minimum and maximum distance between reinforcing bars according to EN 1992-1-1 or corresponding national rules shall apply.

In addition the necessary reinforcement according to static calculation shall be installed according to the instructions in the installation guide provided by the manufacturer.

The lintel blocks (see clause 1.1.3.2) have to be reinforced like beams according to EN 1992-1-1 or corresponding national rules.

Rectangular corners are to be formed according to Annexes 3 and 8. Typical junctions between walls and ceilings are to be formed according to Annex 8.

The lintel blocks shall be supported.

The erection of the storey high panels (see clause 1.1.2) shall be performed according to the installation guide.

Further information is given in the installation guide.

4.2.3 Concreting

For the production of normal concrete EN 206-1 shall apply. The consistency of concrete shall be at least within the lower consistency range F3 when compacted by vibration and at least within the upper consistency range F3 when compacted by poking.

The maximum aggregate size shall be at least 8 mm and shall not exceed 16 mm.

Furthermore the concrete shall have rapid or medium strength development according to EN 206-1, Table 12.

Placing the concrete shall be performed only by persons who were instructed in the works and in the proper handling of the shuttering system.

Placing the concrete shall be performed in layers of maximum 1 m at a maximum concreting rate of 3 m/h.

If equivalent national rules are not available, the following instructions shall be considered:

Horizontal cold joints are to be arranged preferably at the height of the floor. If cold joints cannot be avoided within the height between the floors, vertical starter bars shall be installed. The starter bars shall meet the following requirements:

- Two adjacent starter bars shall not be situated in the same plane parallel to the surface of the wall.
- The distance between two starter bars in wall direction shall be at least 10 cm and not larger than 50 cm.
- The total section area of the starter bars shall not be less than 1/2000 of the section area of the concrete.
- Anchorage length of the starter bars on both sides of the cold joint shall be at least 20 cm.

Before the further placing of concrete, cement laitance and detached / loose concrete shall be removed and the cold joints shall be sufficiently pre-wetted. At the time of concreting the surface of the older concrete shall be slightly moist, so that the newly placed concrete can combine well with the older concrete.

If no cold joint is planned, placing of concrete in layers may only be interrupted until the concrete layer placed last has not yet set so that a good and even bond is still possible between the two concrete layers. When using internal vibrators, the vibrating cylinder shall still penetrate into the already compacted lower concrete layer.

The concrete may fall freely only up to a height of 2 m, beyond that the concrete shall be cohered by discharge pipes or concreting tubes with a diameter of 100 mm at the most and shall be led shortly before the place of installation.

Cones from placing concrete are to be avoided by short distances of the places of fill in.

Planning shall allow for sufficient spaces in the reinforcement for discharge pipes or concreting tubes.

After concreting the walls may not deviate from the plumb line more than 5 mm per running meter wall height.

The ceiling shall only be placed on walls made of shuttering blocks when the concrete columns have sufficiently hardened.

4.2.4 Ducts crossing and situated inside the wall

Horizontally passing ducts are to be installed according to the installation guide of the manufacturer and are to be taken into account when designing the wall.

Horizontal ducts situated inside the wall columns and running parallel to the wall surfaces shall be avoided. If absolutely necessary, these are to be taken into account when designing the wall.

Also vertical ducts in the concrete columns shall be considered, if their diameter exceeds 1/6 of the thickness of the concrete columns and the distance of the ducts is less than 2 m.

4.2.5 Reworking and finishes

Walls of the type "DURISOL" are to be protected by finishes (e. g. rendering, plasters, cladding, panelling, coatings). Finishes are not part of the kit and therefore not considered in this ETA. Preferably for external surfaces the rendering systems used should meet the requirements of ETAG 004. The cladding respectively panelling or their substructures shall be anchored in the concrete columns. The execution of the rendering shall be performed according to applicable national rules.

The protection by finishes should be implemented preferably within one month after erecting the load-bearing structure, because of the detrimental influence of weather and UV radiation on the surface of the shuttering leaves of wood-chip concrete.

4.2.6 Fixing of objects

Fixing of objects in the shuttering leaves of wood-chip concrete is not possible. The part of fixings which is significant for the mechanical resistance shall be inside the concrete columns. The influence of the fixing to the reduction of the declared value of thermal resistance $R_{D,wall}$ of walls made of shuttering blocks of wood-chip concrete in end use conditions (shuttering blocks with concrete columns and maybe thermal insulation inserts but without rendering) shall be considered according to EN ISO 6946.

5 Indications to the manufacturer

5.1 Packaging, transport and storage

The shuttering blocks have to be protected against damage, soiling and intensive action of water during transport and storage. If necessary the shuttering blocks shall be covered.

5.2 Use, maintenance, repair

Regular checks should be carried out on renderings and finishes to ensure that any damage is detected and repaired as soon as possible.

The recommendations on use, maintenance and repair in ETAG 009, clause 7.5 shall be considered.

The shuttering blocks have to be protected against high temperature, overheating and intensive exposure to weather and UV radiation. If necessary, the shuttering blocks have to be covered.

Georg Feistel
Head of Department

beglaubigt:
Schwab

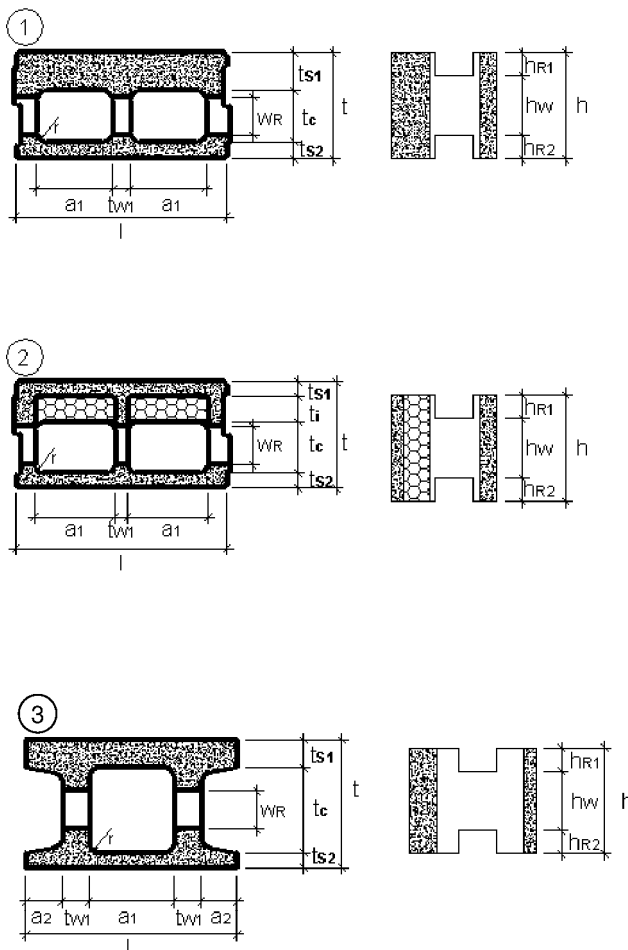

Type	Fig.	t	l	t _c	t _{s1}	t _{s2}	t _{s3}	t _i	t _{w1}	r	a ₁	a ₂	w _R	h _{R1}	h _{R2}	h _w	AR
		mm	mm	mm	mm	mm	mm	mm	mm	mm	mm	mm	mm	mm	mm	mm	mm
DM 15/9 *	1	150	498	90	30	30	-	-	30	15	194	-	80	50	50	150	80
DMi 17/12 *	1	170	498	120	25	25	-	-	40	12.5	184	-	100	30	30	190	60
DMi 20/13Lap *	3	200	498	130	35	35	-	-	55	15	218	85	100	50	50	150	100
DMi 25/18Lap *	3	250	498	180	35	35	-	-	54	20	196	97	100	50	50	150	100
DSi 30/20Lap *	3	300	498	200	65	35	-	-	64	20	200	85	100	50	50	150	100
DM 25/16 *	1	250	498	160	45	45	-	-	30	25	192	-	100	50	50	150	100
DS 25/12 *	1	250	498	120	90	40	-	-	40	25	180	-	100	50	50	150	100
DSs 37,5/12n	2	375	498	120	40	40	-	175	53	25	171	-	100	50	50	150	100
DSs 25/12	2	250	498	120	35	35	-	60	30	20	190	-	100	50	50	150	100
DSs 30/12	2	300	498	120	40	40	-	100	40	5	185	-	100	50	50	150	100

* see clause 2.2.3.1

DURISOL - shuttering blocks made of wood-chip concrete

Standard shuttering blocks

Annex 1

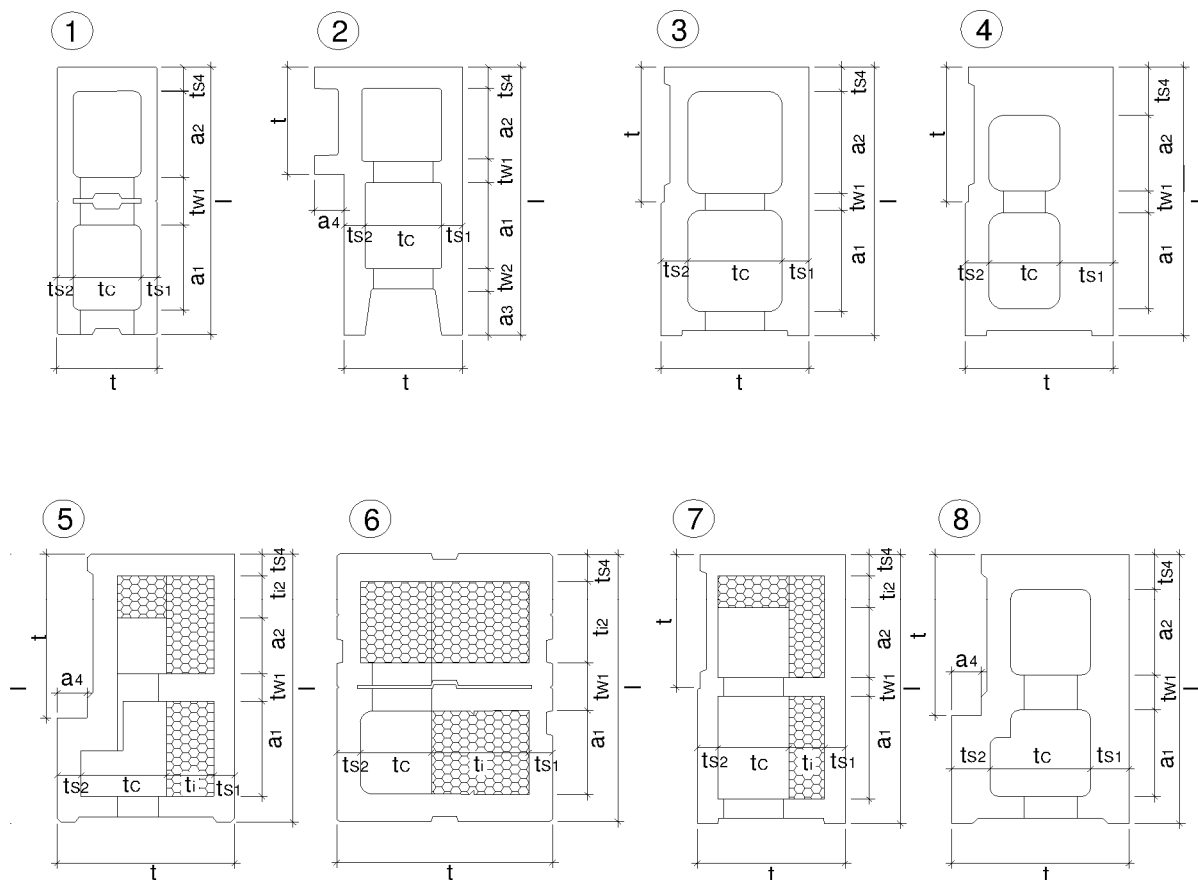

Type	Fig.	t	l	tc	ts1	ts2	ts3	ts4	ti	ti2	tw1	tw2	a1	a2	a3	a4
		mm	mm	mm	mm	mm	mm	mm	mm	mm	mm	mm	mm	mm	mm	mm
DM 15/9 *	1	150	500	90	30	30	-	40	-	-	100	-	160	160	-	-
DMi 17/12 *	1	170	500	120	25	25	-	45	-	-	90	-	160	160	-	-
DMi 20/13Lap *	2	200	500	130	35	35	-	40	-	-	40	40	160	135	85	-
DMi 25/18Lap *	2	250	500	180	35	35	-	40	-	-	40	40	160	135	85	-
Dsi 30/20Lap *	8	300	500	170	65	65	-	65	-	-	65	-	160	160	-	50
DM 25/16 *	3	250	500	160	45	45	-	45	-	-	30	-	190	190	-	-
DS 25/12 *	4	250	500	120	90	40	-	90	-	-	40	-	180	140	-	-
DSs 37,5/12n	6	375	500	120	40	40	-	50	155	155	90	-	155	-	-	-
DSs 25/12	7	250	500	120	35	35	-	40	60	60	35	-	190	130	-	-
DSs 30/12	5	300	500	125	35	40	-	40	100	100	40	-	175	105	-	-

* see clause 2.2.3.1

DURISOL - shuttering blocks made of wood-chip concrete

Stopper blocks / Corner blocks / Universal blocks

Annex 2

Structure of layer on wall corner – types DM 15/9 and DMi 17/12

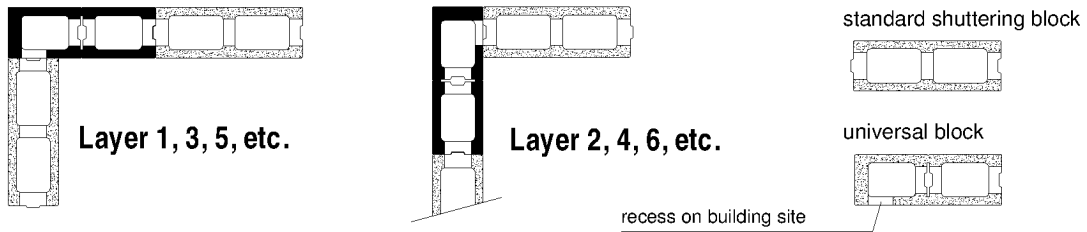

Structure of layer on wall corner – type DMi 20/13Lap

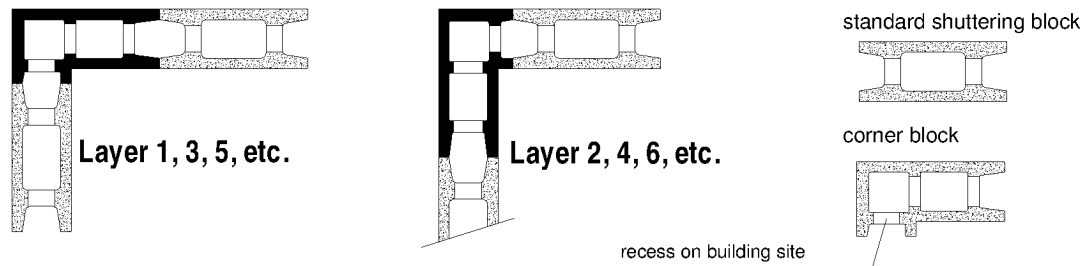

Structure of layer on wall corner – type DMi 25/18Lap

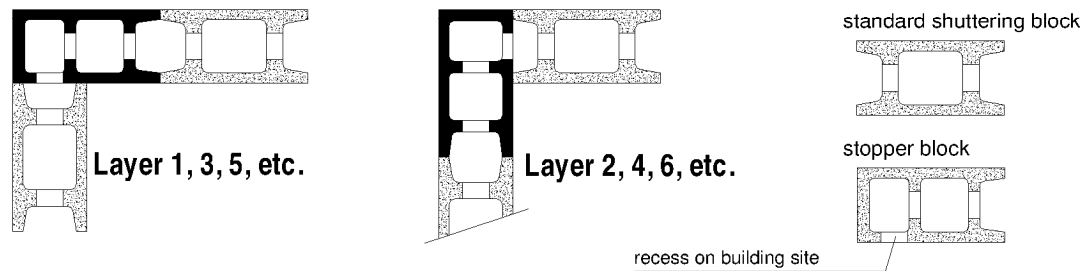

Structure of layer on wall corner – types DS 25/12, DM 25/16 and DSs 25/12

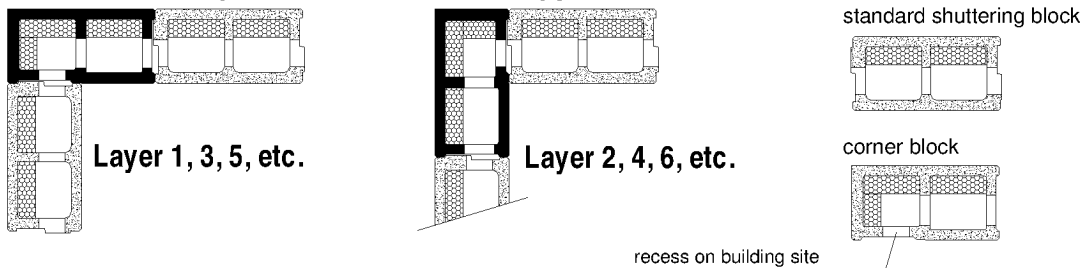

Structure of layer on wall corner – type DSi 30/20Lap

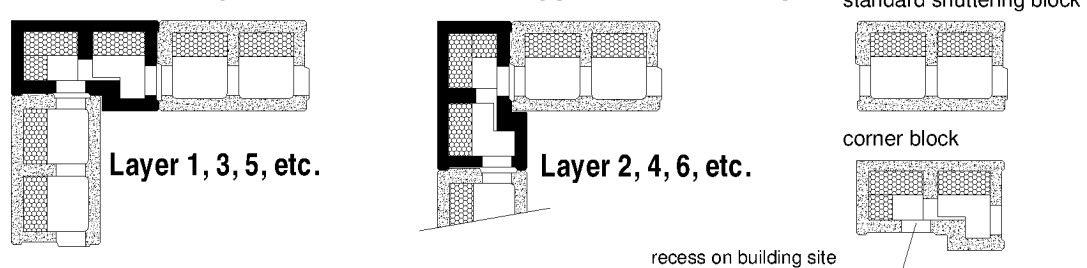

DURISOL - shuttering blocks made of wood-chip concrete

Structure of layer of wall corners of different types of shuttering blocks

Annex 3.1

Cutting the fitting block – types DSs 37,5/12n and DSs 30/12

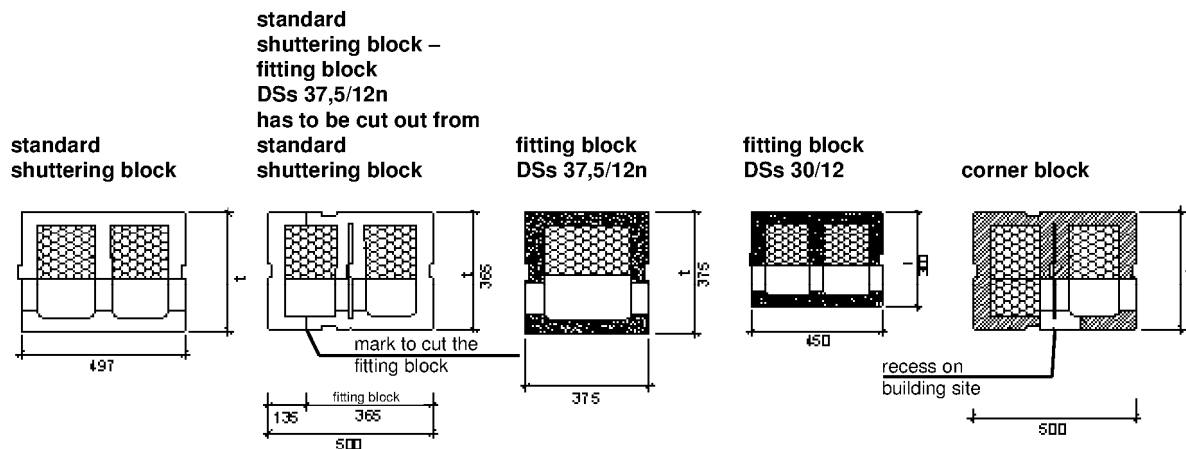

Structure of layer on wall corner – types DSs 37,5/12n and DSs 30/12

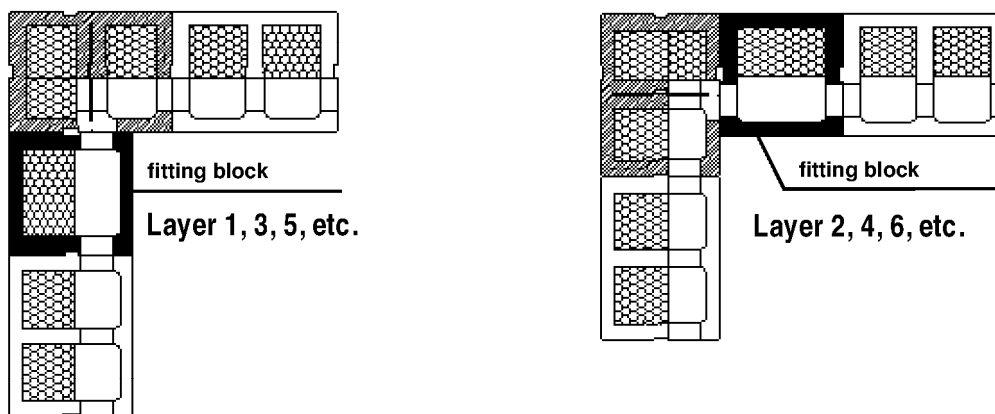

DURISOL - shuttering blocks made of wood-chip concrete

Structure of layer of wall corners of different types of shuttering blocks

Annex 3.2

Type	according to Annex/Figure	Thickness of the wall	Thickness of the concrete column	Web recess area	Area of the concrete column		Volume of the concrete column	Calculation weight of the	
					displaced 20 cm to 25 cm	one upon the other		shuttering block	wall without rendering ⁽¹⁾
		cm	cm	cm ²	cm ² /m	cm ² /m	m ³ /m ²	kN/m ²	kN/m ²
Standard shuttering blocks of wood chip concrete $\rho_{dry} \leq 550 \text{ kg/m}^3$									
DS 25/12	1/1	25	12	100	703	843	0,092	0,856	2,974
DM 25/16	1/1	25	16	100	1035	1207	0,128	0,662	3,593
Standard shuttering blocks of wood chip concrete $\rho_{dry} \leq 600 \text{ kg/m}^3$									
DM 15/9	1/1	15	9	80	non-load bearing		0,072	0,462	2,125
DSi 30/20Lap	1/3	30	20	100	1275	1431	0,153	0,873	4,399
Standard shuttering blocks of wood chip concrete $\rho_{dry} \leq 810 \text{ kg/m}^3$									
DMi 17/12	1/1	17	12	60	758	878	0,095	0,599	2,782
DMi 20/13Lap	1/3	20	13	100	804	965	0,105	0,761	3,182
DMi 25/18Lap	1/3	25	18	100	1139	1347	0,144	0,854	4,156
Standard shuttering blocks of wood chip concrete $\rho_{dry} \leq 550 \text{ kg/m}^3$ with thermal insulation inserts									
DSs 25/12	1/2	25	12	100	759	898	0,097	0,580	2,808
DSs 30/12	1/2	30	12	100	772,0	887	0,096	0,705	2,907
Standard shuttering blocks of wood chip concrete $\rho_{dry} \leq 600 \text{ kg/m}^3$ with thermal insulation inserts									
DSs 37,5/12n	1/2	37,5	12	100	690	810	0,089	0,989	3,041

⁽¹⁾ assumed density of the concrete column $\rho = 2300 \text{ kg/m}^3$

DURISOL - shuttering blocks made of wood-chip concrete

Thicknesses of walls and concrete columns
Dimensions, volumes and weights depending on type of shuttering blocks and material oven dry density

Annex 4

Corner panel

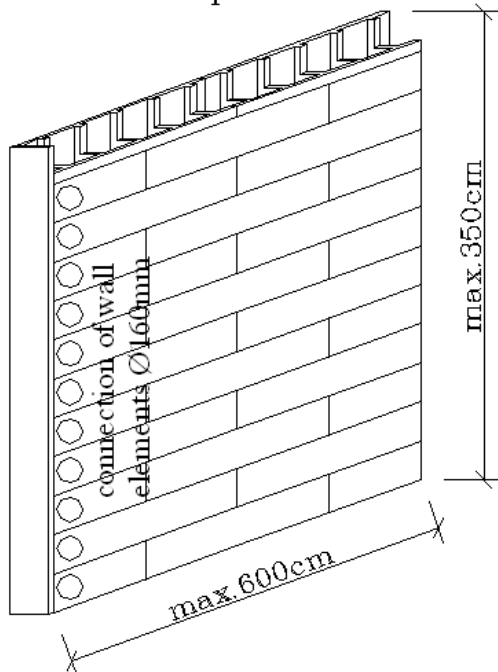

Standard panel

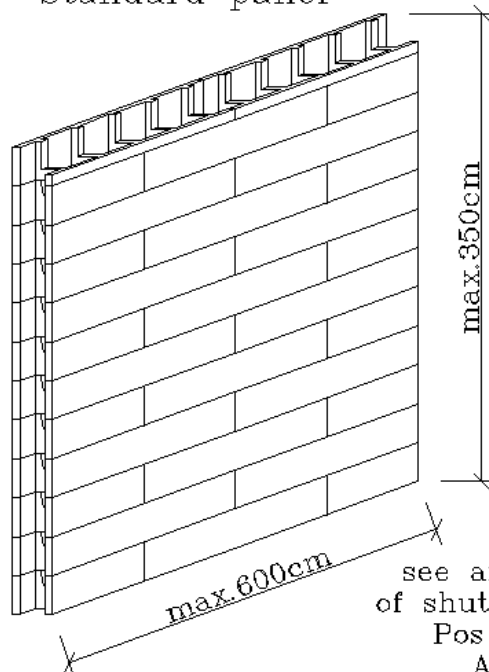

Lintel panel

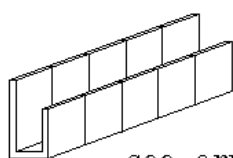

see arrangement
of shuttering blocks
Pos 1
Annex 6

Parapet panel

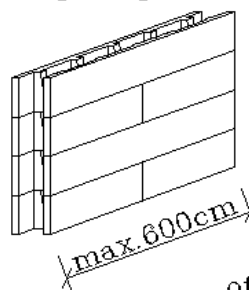

DURISOL - shuttering blocks made of wood-chip concrete

Panels made by pre-assembling the shuttering blocks

Annex 5

Panels - types

arrangement plan – type 1

edges of the ceiling

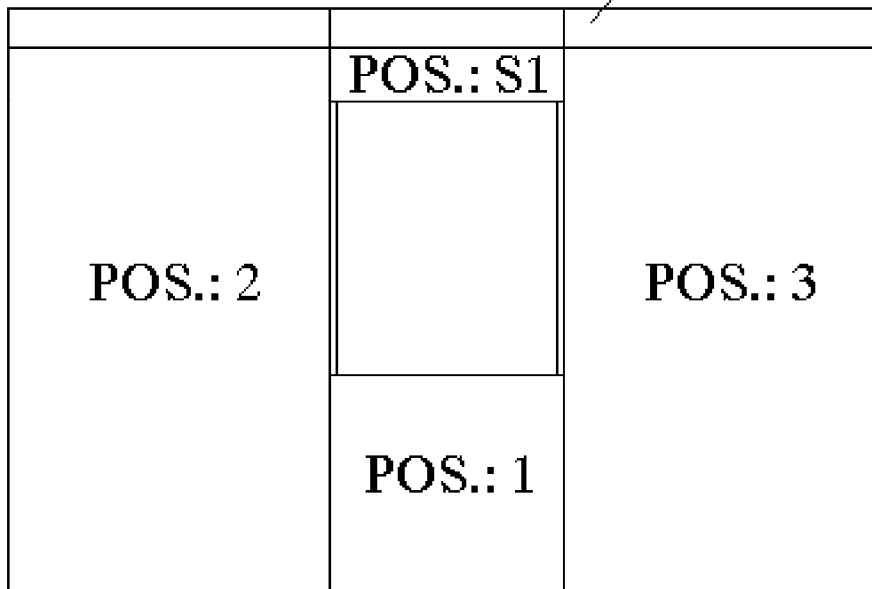

arrangement plan – type 2

edges of the ceiling

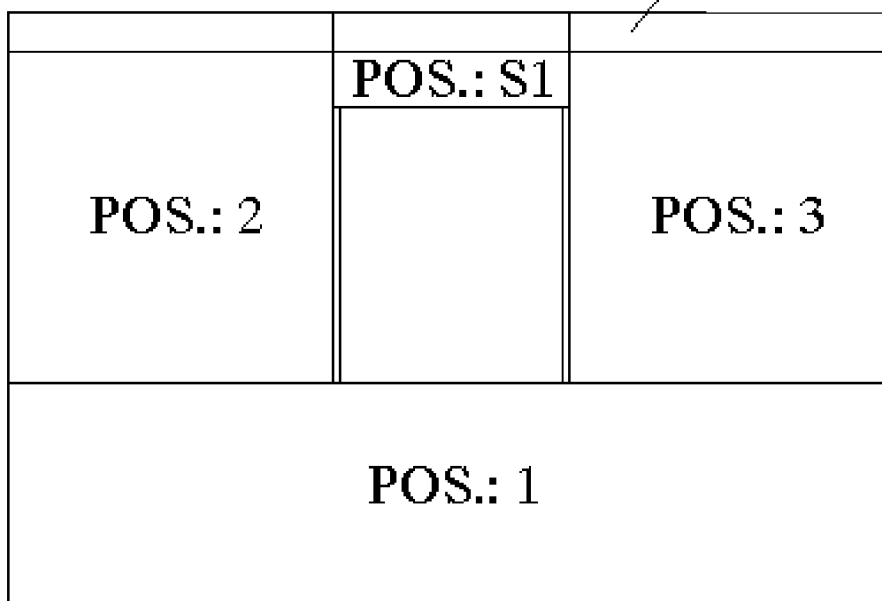

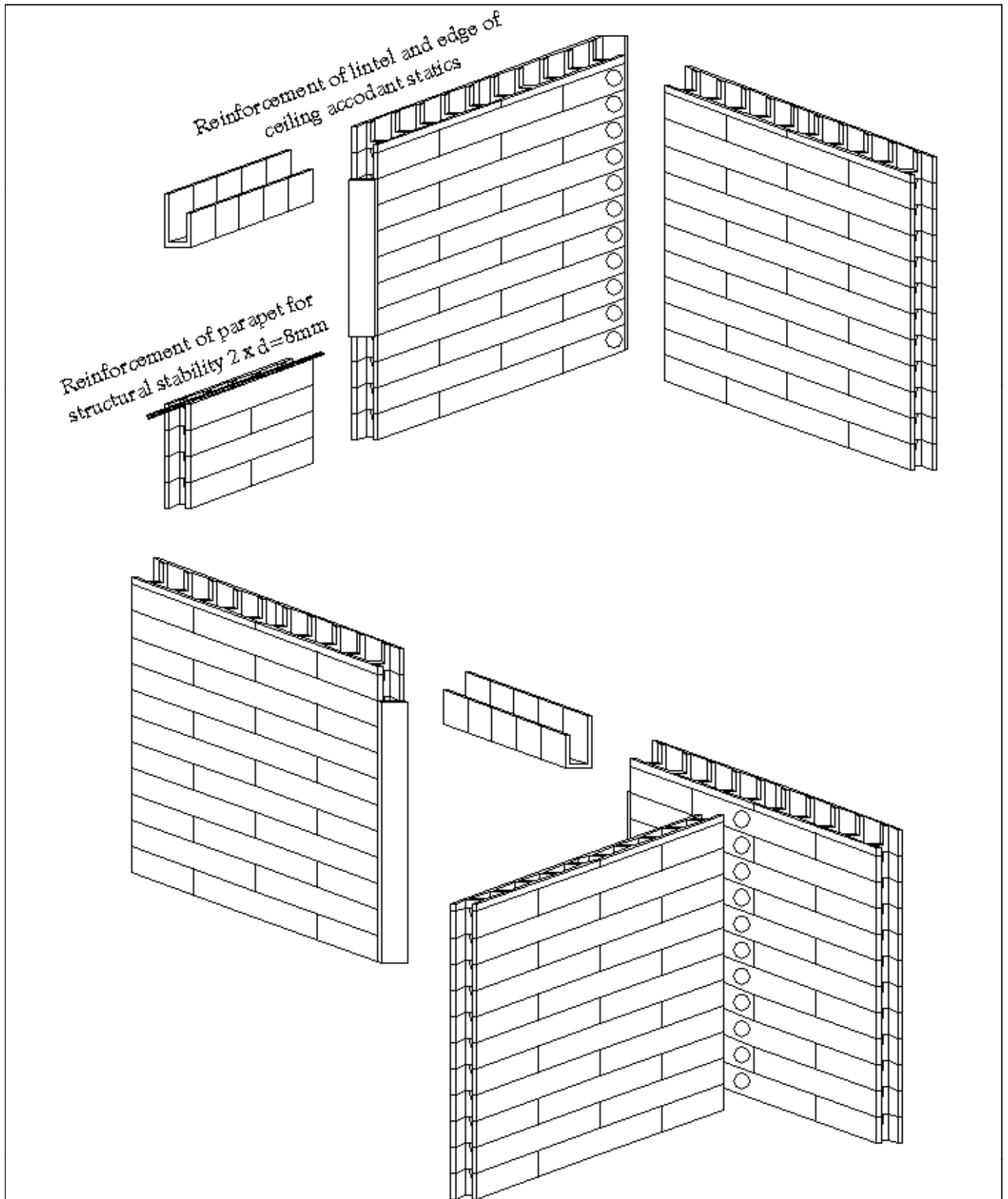

DURISOL - shuttering blocks made of wood-chip concrete

Panels made by pre-assembling the shuttering blocks
3D arrangement plan of type 1

Annex 7

horizontal cross section

horizontal reinforcement (in case of more than five full floors)

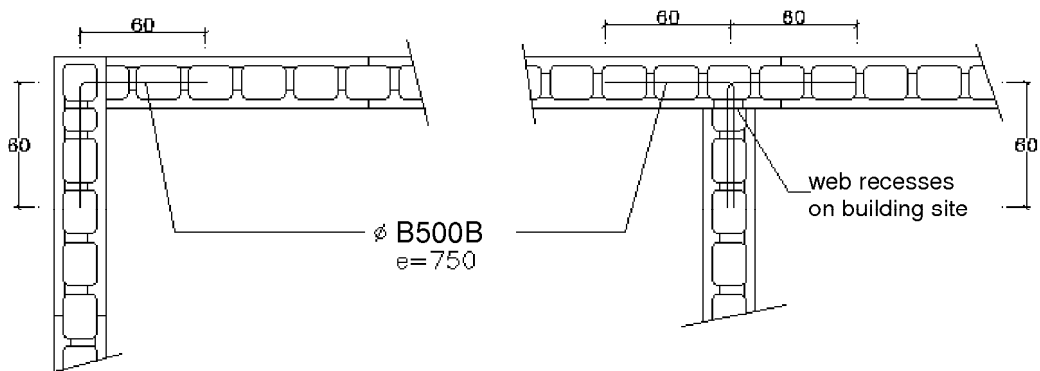

vertical cross section

ceiling supports

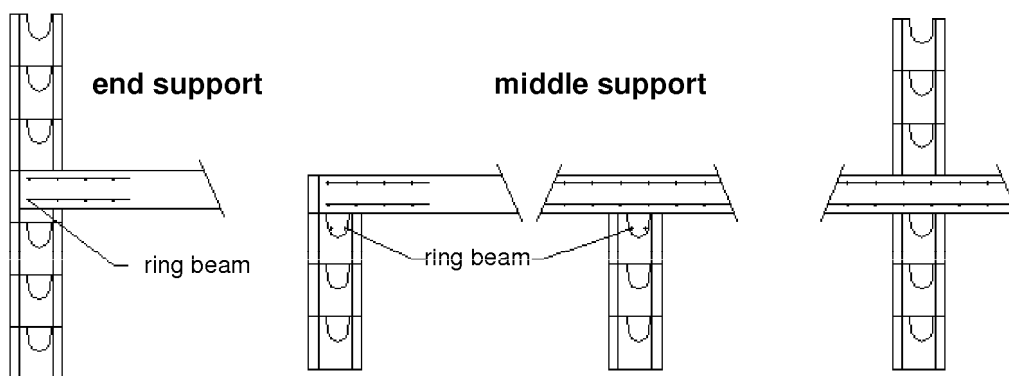

all dimensions in [mm]

DURISOL - shuttering blocks made of wood-chip concrete

Details of horizontal reinforcement and of ceiling supports

Annex 8

standards and guidelines	issue	title	
EN	206-1	2000	Concrete – Part 1: Specification, performance, production and conformity
EN	1992-1-1	2004 + AC:2010	Eurocode 2: Design of concrete structures. – Part 1-1: General rules and rules for buildings
EN	13162	2012	Thermal insulation products for buildings – Factory made mineral wool (MW) products – Specification
EN	13163	2012	Thermal insulation products for buildings – Factory made products of expanded polystyrene (EPS) – Specification
EN	13164	2012	Thermal insulation products for buildings – Factory made extruded polystyrene foam (XPS) products – Specification
EN	13165	2012	Thermal insulation products for buildings – Factory made rigid polyurethane foam (PUR) products – Specification
EN	13170	2012	Thermal insulation products for buildings – Factory made products of expanded cork (ICB) – Specification
EN	13171	2012	Thermal insulation products for buildings – Factory made wood fibre (WF) – Specification
EN	13501-1	2007 + A1:2009	Fire classification of construction products and building elements – Part 1: Classification using test data from reaction to fire tests
EN	13501-2	2007 + A1:2009	Fire classification of construction products and building elements – Part 2: Classification using data from fire resistance tests, excluding ventilation services
EN	14474	2004	Precast concrete products - Concrete with wood-chips as aggregate - Requirements and test methods
EN	15498	2008	Precast concrete products – Wood-chip concrete shuttering blocks – Product properties and performance
EN ISO	6946	2007	Building components and building elements – Thermal resistance and thermal transmittance – Calculation method
EN ISO	10211	2007	Thermal bridges in building construction - Heat flows and surface temperatures - Detailed calculations
EN ISO	10456	2007 + AC:2009	Building materials and products – Hygrothermal properties – Tabulated design values and procedures for determining declared and design thermal values
EN ISO	13788	2001	Hygrothermal performance of building components and building elements – Internal surface temperature to avoid critical surface humidity and interstitial condensation – Calculation methods
ETAG	004	2011	Guideline for European technical approval of "External thermal insulation composite systems with rendering"
ETAG	009	2002-06	Guideline for European technical approval of "Non load bearing permanent shuttering kits/systems based on hollow blocks or panels of insulating materials and sometimes concrete"
DURISOL - shuttering blocks made of wood-chip concrete			Annex 9
List of standards and guidelines			

Holder of approval	Designation of the manufacturing plant on the ETA covering page	Manufacturing plant
DURISOL	T1	Durisol-Werke GmbH Nachf. KG Durisolstraße 1 2481 Achau AUSTRIA
	T2	Durisol-Werk Mautern Durisolstraße 5 8774 Mautern AUSTRIA
	T3	Leier Baustoffe SK s.r.o. Pribylinská 3 83104 Bratislava SLOVAKIA

DURISOL - shuttering blocks made of wood-chip concrete

List of manufacturing plants

Annex 10