



European Technical Approval ETA-06/0108

English translation prepared by DIBt - Original version in German language

Handelsbezeichnung <i>Trade name</i>	Sormat Liebig® Sicherheitsdübel™ <i>Sormat Liebig® Safety Bolt™</i>
Zulassungsinhaber <i>Holder of approval</i>	Sormat Oy Harjutie 5 21290 RUSKO FINNLAND
Zulassungsgegenstand und Verwendungszweck <i>Generic type and use of construction product</i>	Kraftkontrolliert spreizender Dübel aus galvanisch verzinktem Stahl in den Größen M6, M8, M10, M12 und M16 zur Verankerung im Beton <i>Torque-controlled expansion anchor made of galvanised steel of sizes M6, M8, M10, M12 and M16 for use in concrete</i>
Geltungsdauer: <i>Validity:</i>	vom <i>from</i> bis <i>to</i> 9 April 2013 9 April 2018
Herstellwerk <i>Manufacturing plant</i>	Sormat Plant 1

Diese Zulassung umfasst
This Approval contains

15 Seiten einschließlich 8 Anhänge
15 pages including 8 annexes

Diese Zulassung ersetzt
This Approval replaces

ETA-06/0108 mit Geltungsdauer vom 16.05.2011 bis 16.05.2016
ETA-06/0108 with validity from 16.05.2011 to 16.05.2016

I LEGAL BASES AND GENERAL CONDITIONS

- 1 This European technical approval is issued by Deutsches Institut für Bautechnik in accordance with:
 - Council Directive 89/106/EEC of 21 December 1988 on the approximation of laws, regulations and administrative provisions of Member States relating to construction products¹, modified by Council Directive 93/68/EEC² and Regulation (EC) N° 1882/2003 of the European Parliament and of the Council³;
 - *Gesetz über das In-Verkehr-Bringen von und den freien Warenverkehr mit Bauprodukten zur Umsetzung der Richtlinie 89/106/EWG des Rates vom 21. Dezember 1988 zur Angleichung der Rechts- und Verwaltungsvorschriften der Mitgliedstaaten über Bauprodukte und anderer Rechtsakte der Europäischen Gemeinschaften (Bauproduktengesetz - BauPG) vom 28. April 1998⁴, as amended by Article 2 of the law of 8 November 2011⁵;*
 - Common Procedural Rules for Requesting, Preparing and the Granting of European technical approvals set out in the Annex to Commission Decision 94/23/EC⁶;
 - Guideline for European technical approval of "Metal anchors for use in concrete - Part 2: Torque controlled expansion anchors ", ETAG 001-02.
- 2 Deutsches Institut für Bautechnik is authorized to check whether the provisions of this European technical approval are met. Checking may take place in the manufacturing plant. Nevertheless, the responsibility for the conformity of the products to the European technical approval and for their fitness for the intended use remains with the holder of the European technical approval.
- 3 This European technical approval is not to be transferred to manufacturers or agents of manufacturers other than those indicated on page 1, or manufacturing plants other than those indicated on page 1 of this European technical approval.
- 4 This European technical approval may be withdrawn by Deutsches Institut für Bautechnik, in particular pursuant to information by the Commission according to Article 5(1) of Council Directive 89/106/EEC.
- 5 Reproduction of this European technical approval including transmission by electronic means shall be in full. However, partial reproduction can be made with the written consent of Deutsches Institut für Bautechnik. In this case partial reproduction has to be designated as such. Texts and drawings of advertising brochures shall not contradict or misuse the European technical approval.
- 6 The European technical approval is issued by the approval body in its official language. This version corresponds fully to the version circulated within EOTA. Translations into other languages have to be designated as such.

¹ Official Journal of the European Communities L 40, 11 February 1989, p. 12
² Official Journal of the European Communities L 220, 30 August 1993, p. 1
³ Official Journal of the European Union L 284, 31 October 2003, p. 25
⁴ *Bundesgesetzblatt Teil I 1998*, p. 812
⁵ *Bundesgesetzblatt Teil I 2011*, p. 2178
⁶ Official Journal of the European Communities L 17, 20 January 1994, p. 34

II SPECIFIC CONDITIONS OF THE EUROPEAN TECHNICAL APPROVAL

1 Definition of the construction and intended use

1.1 Definition of the product

The Sormat Liebig® Safety Bolt™ in the range of M6, M8, M10, M12 and M16 is an anchor made of galvanised steel which is placed into a drilled hole and anchored by torque-controlled expansion.

An illustration of the product and intended use is given in Annex 1.

1.2 Intended use

The anchor is intended to be used for anchorages for which requirements for mechanical resistance and stability and safety in use in the sense of the Essential Requirements 1 and 4 of Council Directive 89/106 EEC shall be fulfilled and failure of anchorages made with these products would cause risk to human life and/or lead to considerable economic consequences.

The anchor may be used for anchorages with requirements related to resistance to fire.

The anchor is to be used only for anchorages subject to static or quasi-static loading in reinforced or unreinforced normal weight concrete of strength classes C20/25 at minimum and C50/60 at most according to EN 206: 2000-12. It may be anchored in cracked and non-cracked concrete.

The anchor may only be used in structures subject to dry internal conditions.

The provisions made in this European technical approval are based on an assumed working life of the anchor of 50 years. The indications given on the working life cannot be interpreted as a guarantee given by the producer, but are to be regarded only as a means for choosing the right products in relation to the expected economically reasonable working life of the works.

2 Characteristics of the product and methods of verification

2.1 Characteristics of the product

The anchor corresponds to the drawings and provisions given in Annexes 2 and 3. The characteristic material values, dimensions and tolerances of the anchor not given in Annexes 2 and 3 shall correspond to the respective values laid down in the technical documentation⁷ of this European technical approval.

Regarding the requirements concerning safety in case of fire it is assumed that the anchor meets the requirements of class A1 in relation to reaction to fire in accordance with the stipulations of the Commission decision 96/603/EC, amended by 2000/605/EC.

The characteristic values for the design of anchorages are given in Annexes 4 to 6.

⁷ The technical documentation of this European technical approval is deposited at the Deutsches Institut für Bautechnik and, as far as relevant for the tasks of the approved bodies involved in the attestation of conformity procedure, is handed over to the approved bodies.

The characteristic values for the design of anchorages regarding resistance to fire are given in the Annexes 7 and 8. They are valid for use in a system that is required to provide a specific fire resistance class.

Each anchor is marked with the identifying mark of the producer, the trade name, the size of the thread and the maximum thickness of fixture according to Annex 1. In addition, the minimum anchorage depth is marked on the distance sleeve.

The anchor shall only be packaged and supplied as a complete unit.

2.2 Methods of verification

The assessment of fitness of the anchor for the intended use in relation to the requirements for mechanical resistance and stability and safety in use in the sense of the Essential Requirements 1 and 4 has been made in accordance with the "Guideline for European technical approval of Metal Anchors for use in concrete", Part 1 "Anchors in general" and Part 2 "Torque-controlled expansion anchors", on the basis of Option 1.

The assessment of the anchor for the intended use in relation to the requirements for resistance to fire has been made in accordance with the Technical Report TR020 "Evaluation of anchorages in concrete concerning resistance to fire".

In addition to the specific clauses relating to dangerous substances contained in this European technical approval, there may be other requirements applicable to the products falling within its scope (e.g. transposed European legislation and national laws, regulations and administrative provisions). In order to meet the provisions of the Construction Products Directive, these requirements need also to be complied with, when and where they apply.

3 Evaluation and attestation of conformity and CE marking

3.1 System of attestation of conformity

According to the decision 96/582/EG of the European Commission⁸ the system 2(i) (referred to as system 1) of attestation of conformity applies.

This system of attestation of conformity is defined as follows:

System 1: Certification of the conformity of the product by an approved certification body on the basis of:

- (a) Tasks for the manufacturer:
 - (1) factory production control;
 - (2) further testing of samples taken at the factory by the manufacturer in accordance with a prescribed test plan;
- (b) Tasks for the approved body:
 - (3) initial type-testing of the product;
 - (4) initial inspection of factory and of factory production control;
 - (5) continuous surveillance, assessment and approval of factory production control.

Note: Approved bodies are also referred to as "notified bodies".

⁸ Official Journal of the European Communities L 254 of 08.10.1996.

3.2 Responsibilities

3.2.1 Tasks of the manufacturer

3.2.1.1 Factory production control

The manufacturer shall exercise permanent internal control of production. All the elements, requirements and provisions adopted by the manufacturer shall be documented in a systematic manner in the form of written policies and procedures, including records of results performed. This production control system shall insure that the product is in conformity with this European technical approval.

The manufacturer may only use initial / raw / constituent materials stated in the technical documentation of this European technical approval.

The factory production control shall be in accordance with the control plan which is part of the technical documentation of this European technical approval. The control plan is laid down in the context of the factory production control system operated by the manufacturer and deposited at Deutsches Institut für Bautechnik⁹.

The results of factory production control shall be recorded and evaluated in accordance with the provisions of the control plan.

3.2.1.2 Other tasks of manufacturer

The manufacturer shall, on the basis of a contract, involve a body which is approved for the tasks referred to in section 3.1 in the field of anchors in order to undertake the actions laid down in section 3.2.2. For this purpose, the control plan referred to in sections 3.2.1.1 and 3.2.2 shall be handed over by the manufacturer to the approved body involved.

The manufacturer shall make a declaration of conformity, stating that the construction product is in conformity with the provisions of this European technical approval.

3.2.2 Tasks of approved bodies

The approved body shall perform the

- initial type-testing of the product ,
- initial inspection of factory and of factory production control,
- continuous surveillance, assessment and approval of factory production control,

in accordance with the provisions laid down in the control plan.

The approved body shall retain the essential points of its actions referred to above and state the results obtained and conclusions drawn in a written report.

The approved certification body involved by the manufacturer shall issue an EC certificate of conformity of the product stating the conformity with the provisions of this European technical approval.

In cases where the provisions of the European technical approval and its control plan are no longer fulfilled the certification body shall withdraw the certificate of conformity and inform Deutsches Institut für Bautechnik without delay.

3.3 CE marking

The CE marking shall be affixed on each packaging of the anchor. The letters "CE" shall be followed by the identification number of the approved certification body, where relevant, and be accompanied by the following additional information:

- the name and address of the producer (legal entity responsible for the manufacturer),
- the last two digits of the year in which the CE marking was affixed,

⁹ The control plan is a confidential part of the documentation of the European technical approval, but not published together with the European technical approval and only handed over to the approved body involved in the procedure of attestation of conformity.
See section 3.2.2.

- the number of the EC certificate of conformity for the product,
- the number of the European technical approval,
- the number of the guideline for European technical approval,
- use category (ETAG 001-1 Option 1),
- size.

4 Assumptions under which the fitness of the product for the intended use was favourably assessed

4.1 Manufacturing

The European technical approval is issued for the product on the basis of agreed data/information, deposited with Deutsches Institut für Bautechnik, which identifies the product that has been assessed and judged. Changes to the product or production process, which could result in this deposited data/information being incorrect, should be notified to Deutsches Institut für Bautechnik before the changes are introduced. Deutsches Institut für Bautechnik will decide whether or not such changes affect the European technical approval and consequently the validity of the CE marking on the basis of the European technical approval and if so whether further assessment or alterations to the European technical approval shall be necessary.

4.2 Design of anchorages

The fitness of the anchor for the intended use is given under the following conditions:

The anchorages are designed in accordance with the "Guideline for European technical approval of Metal Anchors for Use in Concrete", Annex C, Method A, for torque controlled expansion anchors under the responsibility of an engineer experienced in anchorages and concrete work.

Verifiable calculation notes and drawings are taking account of the loads to be anchored.

The position of the anchor is indicated on the design drawings (e.g. position of the anchor relative to reinforcement or to supports, in cracked or non-cracked concrete, etc.).

The design of anchorages under fire exposure has to consider the conditions given in the Technical Report TR020 "Evaluation of anchorages in concrete concerning resistance to fire". The relevant characteristic anchor values are given in the Annexes 7 and 8. The design method covers anchors with a fire attack from one side only. If the fire attack is from more than one side, the design method may be taken only, if the edge distance of the anchor is $c \geq 300$ mm.

4.3 Installation of anchors

The fitness for use of the anchor can only be assumed if the anchor is installed as follows:

- Anchor installation carried out by appropriately qualified personnel and under the supervision of the person responsible for technical matters of the site,
- Use of the anchor only as supplied by the manufacturer without exchanging the components of an anchor,
- Anchor installation in accordance with the manufacturer's specifications and drawings and using the appropriate tools,
- Checks before placing the anchor to ensure that the strength class of the concrete in which the anchor is to be placed is in the range given and is not lower than that of the concrete to which the characteristic loads apply,
- Check of concrete being well compacted, e.g. without significant voids,
- Edge distances and spacings not less than the specified values without minus tolerances,

- Positioning of the drill holes without damaging the reinforcement,
- In case of aborted hole: new drilling at a minimum distance away of twice the depth of the aborted hole or smaller distance if the aborted drill hole is filled with high strength mortar and if under shear or oblique tension load it is not in the direction of load application,
- Cleaning of the hole of drilling dust,
- Anchor installation such that the effective anchorage depth is complied with. This compliance is ensured when the embedment mark of the anchor does no more exceed the concrete surface,
- Application of the torque moment given in Annex 4 using a calibrated torque wrench.

5 Responsibility of the manufacturer

The manufacturer is responsible to ensure that the information on the specific conditions according to 1 and 2 including Annexes referred to as well as sections 4.2 and 4.3 is given to those who are concerned. This information may be made by reproduction of the respective parts of the European technical approval. In addition all installation data shall be shown clearly on the package and/or on an enclosed instruction sheet, preferably using illustration(s).

The minimum data required are:

- Diameter of drill bit,
- Thread diameter,
- Maximum thickness of the fixture,
- Minimum effective anchorage depth,
- Minimum hole depth,
- Torque moment,
- Information on the installation procedure, including cleaning of the hole, preferably by means of an illustration,
- Reference to any special installation equipment needed,
- Identification of the manufacturing batch.

All data shall be presented in a clear and explicit form.

Georg Feistel
Head of Department

beglaubigt:
Baderschneider

Sormat Liebig Safety Bolt™

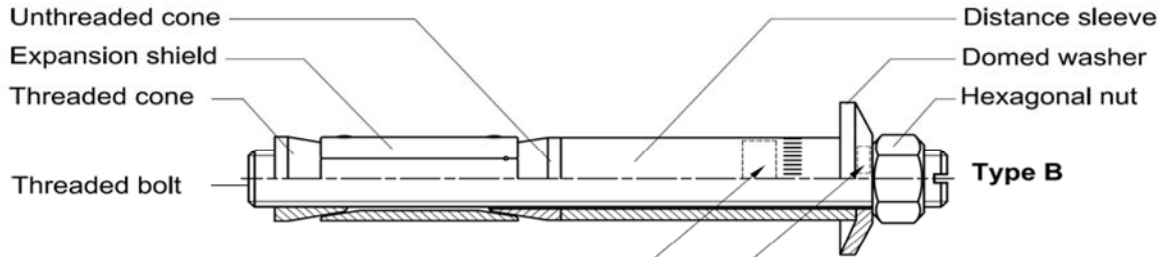

Marking:

Identifying mark: 
 Thread size: M ..
 Max. fixture thickness: t_{fix}
 Setting depth marking: knurl or groove

For example:  M10/40

Marking:

Trade name: S (Safety Bolt)

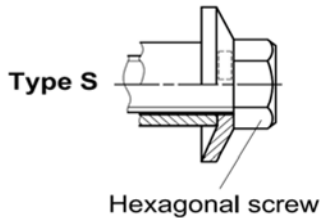

Sormat Liebig Safety Bolt™ after installation

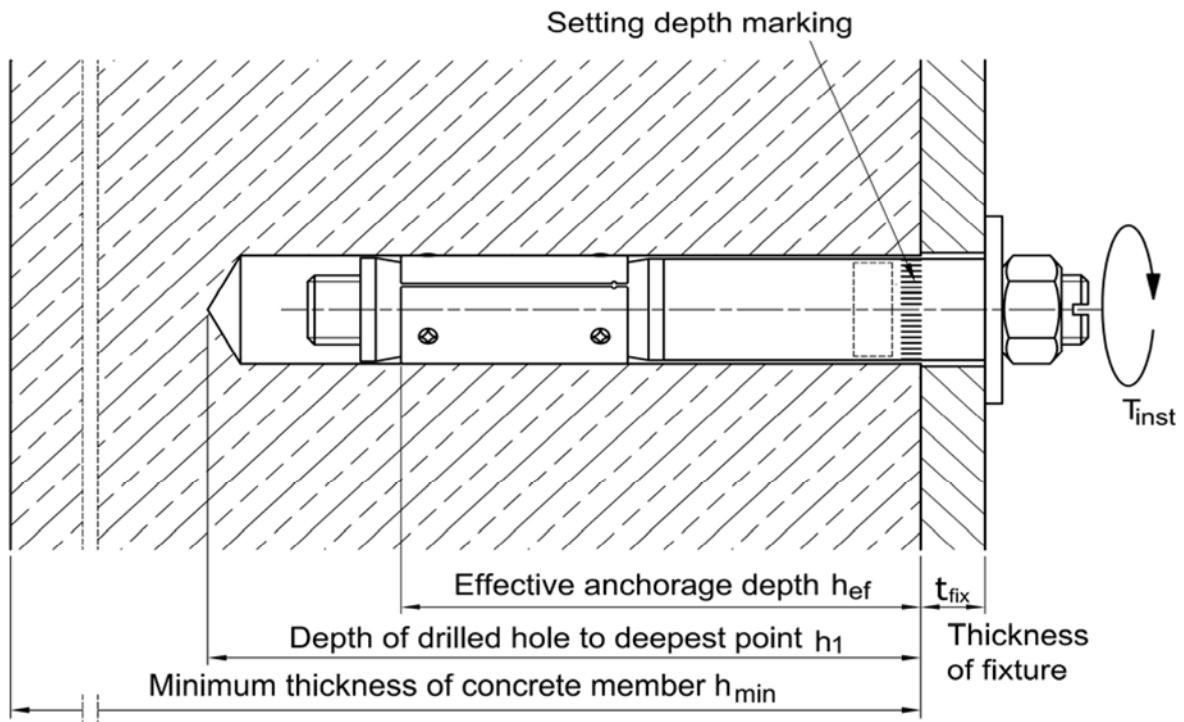

Sormat Liebig® Safety Bolt™

Product and intended use

Annex 1

Sormat Liebig Safety Bolt™

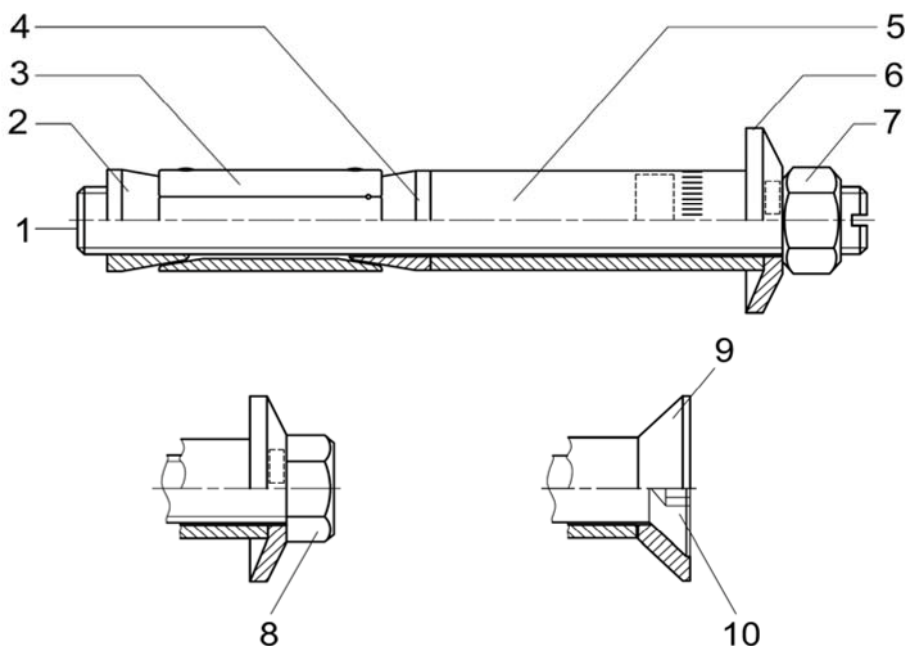

Table 1: Materials

Part	Designation	Material ^{1) 2)}
1	Threaded bolt	EN ISO 898-1: grade 8.8
2	Threaded cone	EN10263: 1.0214 / EN 10087: 1.0718
3	Expansion shield	EN 10025: 1.0037 / EN 10139: 1.0330
4	Unthreaded cone	EN10263: 1.0214 / EN 10087: 1.0718
5	Distance sleeve	EN 10025: 1.0037 / EN 10139: 1.0330
6	Domed washer	EN 10139: 1.0330
7	Hexagonal nut	EN ISO 898-2: grade 8
8	Hexagonal screw	EN ISO 898-1: grade 8.8
9	Countersunk washer	EN 10025: 1.0037 / EN 10087: 1.0718
10	Countersunk screw	EN ISO 898-1: grade 8.8

¹⁾ Parts 1 - 10 zinc electroplated according to EN ISO 4042 $\geq 5 \mu\text{m}$, passivated.

²⁾ Parts 2, 6, 7 and 9 with lubrication.

Sormat Liebig® Safety Bolt™

Materials

Annex 2

Sormat Liebig Safety Bolt™

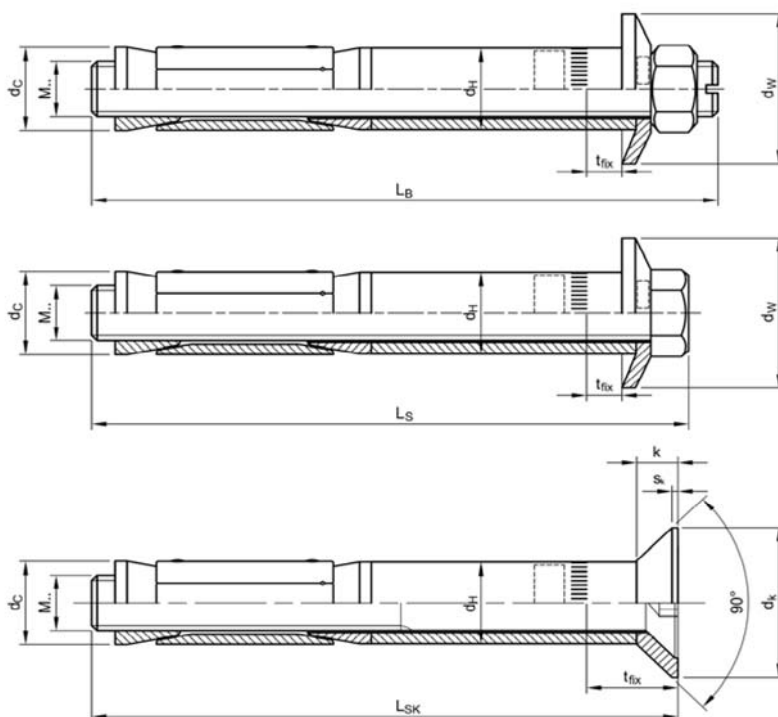

Type B

Type S

Type SK

Table 2: Dimensions of the anchors

Anchor size		M6-10/45/..	M8-12/55/..	M10-15/70/..	M12-20/80/..	M16-25/100/..
Type B	$t_{fix}^{1)}$ [mm]	0 - 200	0 - 200	0 - 200	0 - 200	0 - 200
	L_B [mm]	65 - 265	80 - 280	95 - 295	115 - 315	145 - 345
Type S	$t_{fix}^{1)}$ [mm]	1 - 200	1 - 200	2 - 200	5 - 200	5 - 200
	L_S [mm]	65 - 265	76 - 275	93 - 291	113 - 308	145 - 340
Type SK	$t_{fix}^{1)}$ [mm]	6 - 200	8 - 200	8 - 200	10 - 200	15 - 200
	L_{SK} [mm]	60 - 250	75 - 265	90 - 280	105 - 295	135 - 320
	s_k [mm]	0.5	0.5	1	1	1
	k [mm]	5.5	6.5	7	8	14
	d_k [mm]	20	24	27	33	50
d_C	[mm]	10	12	15	19.7	24.7
d_H	[mm]	9.5	11.7	14.7	19	24
d_W	[mm]	15	20	25	30	40

¹⁾ t_{fix} = Thickness of fixture

Sormat Liebig® Safety Bolt™

Dimensions of the anchors

Annex 3

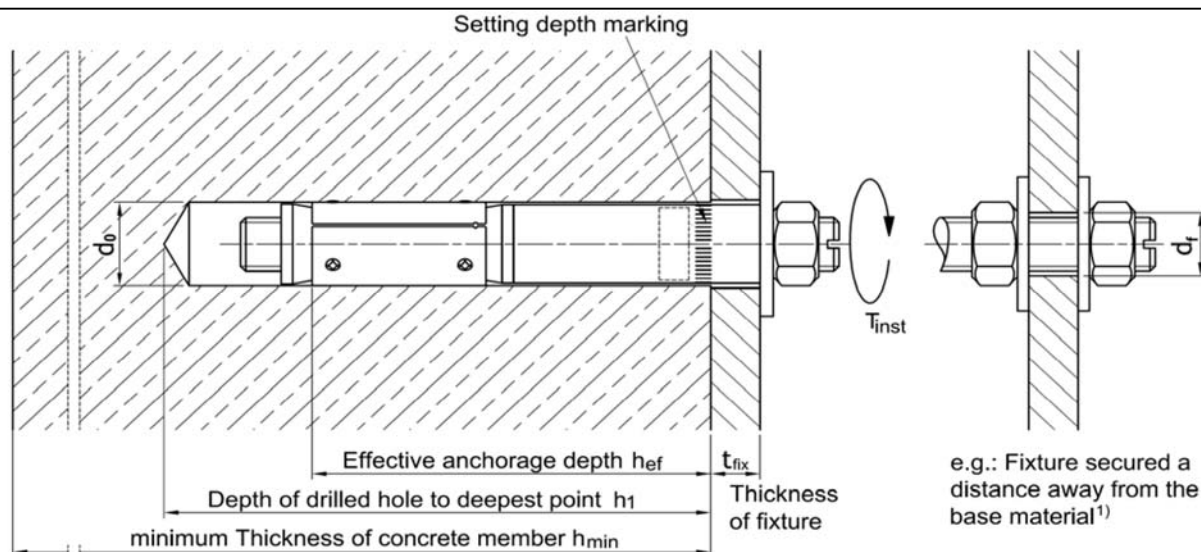

Table 3: Installation data

Sormat Liebig Safety Bolt™			Anchor size				
			M6 10/45/..	M8 12/55/..	M10 15/70/..	M12 20/80/..	M16 25/100/..
Nominal diameter of drill bit	d_o	[mm]	10	12	15	20	25
Cutting diameter of drill bit	$d_{cut} \leq$	[mm]	10.45	12.5	15.5	20.55	25.55
Depth of drilled hole to deepest point	$h_1 \geq$	[mm]	60	70	85	100	125
Diameter of clearance hole in the fixture	$d_f \leq$	[mm]	12	14	17	21	26
	$d_f^{1)} \leq$	[mm]	7	9	12	14	18
Maximum thickness of fixture	$t_{fix} \leq$	[mm]	200	200	200	200	200
Width across flats type B + S	SW	[mm]	10	13	17	19	24
Width across flats type SK	S	[mm]	4	5	6	8	10
Torque moment type B	T_{inst}	[Nm]	8	15	40	70	115
Torque moment type S			8	20	60	90	170
Torque moment type SK			12	20	60	90	190

¹) Mounting on the threaded bolt (only type B)

Table 4: Minimum thickness of concrete member, spacing and edge distance

Sormat Liebig Safety Bolt™			Anchor size				
			M6 10/45/..	M8 12/55/..	M10 15/70/..	M12 20/80/..	M16 25/100/..
Minimum thickness of concrete member	h_{min}	[mm]	100	110	140	160	200
Minimum spacing	s_{min}	[mm]	60	100	150	200	250
	for $c \geq$	[mm]	130	200	300	500	600
Minimum edge distance	c_{min}	[mm]	80	100	150	200	250
	for $s \geq$	[mm]	140	200	250	380	440

Intervals may be interpolated linearly.

Sormat Liebig® Safety Bolt™

Installation data,
Minimum thickness of concrete,
Spacing and edge distance

Annex 4

Table 5: Design method A: Characteristic values for tension loads

Sormat Liebig Safety Bolt™			Anchor size				
			M6 10/45/..	M8 12/55/..	M10 15/70/..	M12 20/80/..	M16 25/100/..
Steel failure							
Characteristic resistance	$N_{Rk,s}$	[kN]	16.1	29.3	46.4	67.4	125.3
Partial safety factor	$\gamma_{Ms}^{1)}$	[-]	1.5				
Pull-out failure							
Characteristic resistance in cracked concrete C20/25	$N_{Rk,p}$	[kN]	6	9	16	— ⁴⁾	— ⁴⁾
Characteristic resistance in non-cracked concrete C20/25	$N_{Rk,p}$	[kN]	7.5	12	20	— ⁴⁾	— ⁴⁾
Increasing factors for $N_{Rk,p}$	ψ_C	C25/30	1.10				
		C30/37	1.22				
		C35/45	1.34				
		C40/50	1.41				
		C45/55	1.48				
		C50/60	1.55				
Partial safety factor	$\gamma_{Mp}^{1)}$	[-]	1.8 ²⁾	1.8 ²⁾	1.5 ³⁾	1.5 ³⁾	1.5 ³⁾
Concrete cone failure							
Effective anchorage depth	h_{ef}	[mm]	45	55	70	80	100
Spacing	$s_{cr,N}$	[mm]	3 x h_{ef}				
Edge distance	$c_{cr,N}$	[mm]	1.5 x h_{ef}				
Partial safety factor	$\gamma_{Mc}^{1)}$	[-]	1.8 ²⁾	1.8 ²⁾	1.5 ³⁾	1.5 ³⁾	1.5 ³⁾
Concrete splitting failure							
Spacing (splitting)	$s_{cr,sp}$	[mm]	5 x h_{ef}				
Edge distance (splitting)	$c_{cr,sp}$	[mm]	2.5 x h_{ef}				
Partial safety factor	$\gamma_{M,sp}^{1)}$	[-]	1.8 ²⁾	1.8 ²⁾	1.5 ³⁾	1.5 ³⁾	1.5 ³⁾

¹⁾ In absence of other national regulations.

³⁾ The installation safety factor $\gamma_2 = 1.0$ is included.

²⁾ The installation safety factor $\gamma_2 = 1.2$ is included.

⁴⁾ Pull-out failure not decisive.

Table 6: Displacements under tension loads

Sormat Liebig Safety Bolt™			Anchor size				
			M6 10/45/..	M8 12/55/..	M10 15/70/..	M12 20/80/..	M16 25/100/..
Cracked concrete C20/25	N	[kN]	2.4	3.6	7.6	12.3	17.2
	d_{N0}	[mm]	0.2	0.4	0.4	0.6	0.6
	$d_{N\infty}$	[mm]	0.8	0.8	0.8	0.8	0.8
Non-cracked concrete C20/25	N	[kN]	3.0	4.8	9.5	17.2	24.0
	d_{N0}	[mm]	0.2	0.3	0.3	0.4	0.4
	$d_{N\infty}$	[mm]	0.8	0.8	0.8	0.8	0.8

Sormat Liebig® Safety Bolt™

Design method A:
Characteristic values for tension loads,
Displacements

Annex 5

Table 7: Design method A
Characteristic values for shear loads

Sormat Liebig Safety Bolt™			Anchor size				
			M6 10/45/..	M8 12/55/..	M10 15/70/..	M12 20/80/..	M16 25/100/..
Steel failure without lever arm							
Characteristic resistance	$V_{Rk,s}$	[kN]	15	25	39	60	96
Partial safety factor	$\gamma_{Ms}^{1)}$	[-]	1.25				
Steel failure with lever arm							
Characteristic bending moment	$M_{Rk,s}^0$	[Nm]	12	30	60	105	266
Partial safety factor	$\gamma_{Ms}^{1)}$	[-]	1.25				
Concrete pry-out failure							
Factor in equation (5.6) of ETAG 001 Annex C, 5.2.3.3	k	[-]	1		2		
Partial safety factor	$\gamma_{Mc}^{1)}$	[-]	1.5 ²⁾				
Concrete edge failure							
Effective length of anchor under shear load	ℓ_f	[mm]	45	55	70	80	100
Outside diameter of anchor	d_{nom}	[mm]	10	12	15	20	25
Partial safety factor	$\gamma_{Mc}^{1)}$	[-]	1.5 ²⁾				

¹⁾ In absence of other national regulations.

²⁾ The installation safety factor $\gamma_2 = 1.0$ is included.

Table 8: Displacements under shear loads

Sormat Liebig Safety Bolt™			Anchor size				
			M6 10/45/..	M8 12/55/..	M10 15/70/..	M12 20/80/..	M16 25/100/..
Cracked and non-cracked concrete C20/25 - C50/60	V	[kN]	8.6	14.3	22.3	34.3	54.9
	d_{v0}	[mm]	2.5	2.9	3.2	4.1	5.0
	$d_{v\infty}$	[mm]	3.8	4.4	4.5	6.2	7.5

Sormat Liebig® Safety Bolt™

Design method A:
Characteristic values for shear loads,
Displacements

Annex 6

Table 8: Design method A
Characteristic tension resistance in cracked and non-cracked concrete
C20/25 to C50/60 under fire exposure.

Sormat Liebig Safety Bolt™				Anchor size				
				M6 10/45/..	M8 12/55/..	M10 15/70/..	M12 20/80/..	M16 25/100/..
Steel failure								
Characteristic resistance	R30	$N_{Rk,s,fi}$	[kN]	0.2	0.4	0.9	1.7	3.1
	R60	$N_{Rk,s,fi}$	[kN]	0.2	0.3	0.8	1.3	2.4
	R90	$N_{Rk,s,fi}$	[kN]	0.1	0.3	0.6	1.1	2.0
	R120	$N_{Rk,s,fi}$	[kN]	0.1	0.2	0.5	0.8	1.6
Pull-out failure								
Characteristic resistance	R30	$N_{Rk,p,fi}$	[kN]	1.5	2.3	4.0	2)	
	R60	$N_{Rk,p,fi}$	[kN]					
	R90	$N_{Rk,p,fi}$	[kN]					
	R120	$N_{Rk,p,fi}$	[kN]	1.2	1.8	3.2		
Concrete cone failure								
Characteristic resistance	R30	$N^0_{Rk,c,fi}$	[kN]	3.4	5.7	10.4	14.5	25.3
	R60							
	R90							
	R120	$N^0_{Rk,c,fi}$	[kN]	2.7	4.5	8.3	11.6	20.2
Spacing		$s_{cr,N}$	[mm]	4 x h_{ef}				
		s_{min}	[mm]	60	100	150	200	250
Edge distance		$c_{cr,N}$	[mm]	2 x h_{ef}				
		c_{min}	[mm]	90	110	140	160	200
Fire attack from more than one side: ≥ 300 mm								
Partial safety factor								
For resistance under fire exposure		$\gamma_{M,fi}$	[-]	1.0 ¹⁾				

- 1) In absence of other national regulations the partial safety factor for resistance under fire exposure $\gamma_{M,fi} = 1.0$ is recommended.
- 2) Pull-out failure mode is not decisive.

Sormat Liebig® Safety Bolt™

Design method A:
Characteristic values of tension resistance under fire exposure

Annex 7

Table 9: Design method A
Characteristic shear resistance in cracked and non-cracked concrete
C20/25 to C50/60 under fire exposure.

Sormat Liebig Safety Bolt™				Anchor size				
				M6 10/45/..	M8 12/55/..	M10 15/70/..	M12 20/80/..	M16 25/100/..
Steel failure without lever arm								
Characteristic resistance	R30	$V_{Rk,s,fi}$	[kN]	0.2	0.4	0.9	1.7	3.1
	R60	$V_{Rk,s,fi}$	[kN]	0.2	0.3	0.8	1.3	2.4
	R90	$V_{Rk,s,fi}$	[kN]	0.1	0.3	0.6	1.1	2.0
	R120	$V_{Rk,s,fi}$	[kN]	0.1	0.2	0.5	0.8	1.6
Steel failure with lever arm								
Characteristic resistance	R30	$M^0_{Rk,s,fi}$	[Nm]	0.2	0.4	1.1	2.6	6.6
	R60	$M^0_{Rk,s,fi}$	[Nm]	0.1	0.3	1.0	2.0	5.0
	R90	$M^0_{Rk,s,fi}$	[Nm]	0.1	0.3	0.7	1.7	4.3
	R120	$M^0_{Rk,s,fi}$	[Nm]	0.1	0.2	0.6	1.3	3.3
Concrete pry-out failure								
Factor in equation (5.6) of ETAG 001 Annex C, 5.2.3.3		k	[-]	1.0		2.0		
Characteristic resistance	R30	$V_{Rk,cp,fi}$	[kN]	3.4	5.7	20.7	28.9	50.5
	R60							
	R90							
	R120	$V_{Rk,cp,fi}$	[kN]					
Concrete edge failure								
The initial value $V^0_{Rk,cp,fi}$ of the characteristic resistance in concrete C20/25 to C50/60 under fire exposure may be determined by:				$\leq R90$	$V^0_{Rk,c,fi} = 0,25 \times V^0_{Rk,c}$			
				$= R120$	$V^0_{Rk,c,fi} = 0,20 \times V^0_{Rk,c}$			
With $V^0_{Rk,c}$ initial value of the characteristic resistance in non-cracked concrete C20/25 under normal temperature.								
Partial safety factor								
For resistance under fire exposure		$\gamma_{M,fi}$	[-]	1.0 ¹⁾				

1) In absence of other national regulations the partial safety factor for resistance under fire exposure $\gamma_{M,fi} = 1.0$ is recommended.

Sormat Liebig® Safety Bolt™

Design method A:
Characteristic values of shear resistance under fire exposure

Annex 8