



European Technical Approval ETA-06/0131

English translation prepared by DIBt - Original version in German language

Handelsbezeichnung
Trade name

MAURER MSM[®] Kalotten- und Zylinderlager
MAURER MSM[®] Spherical and Cylindrical Bearing

Zulassungsinhaber
Holder of approval

Maurer Söhne GmbH & Co. KG
Frankfurter Ring 193
80807 München

Zulassungsgegenstand
und Verwendungszweck
*Generic type and use
of construction product*

Kalotten- und Zylinderlager mit besonderem Gleitwerkstoff
Spherical and cylindrical bearing with special sliding material

Geltungsdauer:
Validity: vom
from
bis
to

24 May 2013
24 May 2018

Herstellwerke
Manufacturing plants

Maurer Söhne GmbH & Co. KG
Frankfurter Ring 193
80807 München

Maurer Bridge Accessories Co.Ltd
Fangzhou Road
Luhe, Nanjing 211500
Jiangsu, PRC
China

Sanfield (India) Limited
13-A, D-Sector,
Industrial Area
Govindpura
Bhopal - 462023
India

Diese Zulassung umfasst
This Approval contains

32 Seiten einschließlich 5 Anhänge
32 pages including 5 annexes

Diese Zulassung ersetzt
This Approval replaces

ETA-06/0131 mit Geltungsdauer vom 19.09.2011 bis 20.06.2016
ETA-06/0131 with validity from 19.09.2011 to 20.06.2016

I LEGAL BASES AND GENERAL CONDITIONS

- 1 This European technical approval is issued by Deutsches Institut für Bautechnik in accordance with:
 - Council Directive 89/106/EEC of 21 December 1988 on the approximation of laws, regulations and administrative provisions of Member States relating to construction products¹, modified by Council Directive 93/68/EEC² and Regulation (EC) N° 1882/2003 of the European Parliament and of the Council³;
 - *Gesetz über das In-Verkehr-Bringen von und den freien Warenverkehr mit Bauprodukten zur Umsetzung der Richtlinie 89/106/EWG des Rates vom 21. Dezember 1988 zur Angleichung der Rechts- und Verwaltungsvorschriften der Mitgliedstaaten über Bauprodukte und anderer Rechtsakte der Europäischen Gemeinschaften (Bauproduktengesetz - BauPG) vom 28. April 1998⁴, as amended by Article 2 of the law of 8 November 2011⁵;*
 - Common Procedural Rules for Requesting, Preparing and the Granting of European technical approvals set out in the Annex to Commission Decision 94/23/EC⁶.
- 2 Deutsches Institut für Bautechnik is authorized to check whether the provisions of this European technical approval are met. Checking may take place in the manufacturing plant. Nevertheless, the responsibility for the conformity of the products to the European technical approval and for their fitness for the intended use remains with the holder of the European technical approval.
- 3 This European technical approval is not to be transferred to manufacturers or agents of manufacturers other than those indicated on page 1, or manufacturing plants other than those indicated on page 1 of this European technical approval.
- 4 This European technical approval may be withdrawn by Deutsches Institut für Bautechnik, in particular pursuant to information by the Commission according to Article 5(1) of Council Directive 89/106/EEC.
- 5 Reproduction of this European technical approval including transmission by electronic means shall be in full. However, partial reproduction can be made with the written consent of Deutsches Institut für Bautechnik. In this case partial reproduction has to be designated as such. Texts and drawings of advertising brochures shall not contradict or misuse the European technical approval.
- 6 The European technical approval is issued by the approval body in its official language. This version corresponds fully to the version circulated within EOTA. Translations into other languages have to be designated as such.

¹ Official Journal of the European Communities L 40, 11 February 1989, p. 12
² Official Journal of the European Communities L 220, 30 August 1993, p. 1
³ Official Journal of the European Union L 284, 31 October 2003, p. 25
⁴ *Bundesgesetzblatt Teil I 1998*, p. 812
⁵ *Bundesgesetzblatt Teil I 2011*, p. 2178
⁶ Official Journal of the European Communities L 17, 20 January 1994, p. 34

II SPECIFIC CONDITIONS OF THE EUROPEAN TECHNICAL APPROVAL

1 Definition of the product and intended use

1.1 Definition of the construction product

The MAURER MSM[®] Spherical or Cylindrical Bearing is a structural bearing which permits rotation and displacement movements by a plane and a curved sliding surface between bearing plates of steel (see Annex A). The subject of the ETA is the complete bearing, including, if relevant, the necessary guides or restraints. For the purpose of controlling the degree of freedom the bearings may be combined with flat sliding elements, guides and restraining rings described in this ETA. As an alternative to figure A.1 in Annex A, the bearing may also be used upside down, i.e. with flat sliding surfaces lying below (meaningful, for example in the case of steel bridges).

The spherical or cylindrical bearing is designed according to EN 1337-1:2000. MSM[®], a special sliding material made of UHMWPE (Ultra high molecular weight polyethylene) suitable for low and high temperatures outside the scope of EN 1337-2:2004 with improved wear resistance and load-bearing capacity is used for the sliding surfaces of the bearing.

Sliding surfaces with a diameter of the circumscribing circle of MSM[®] sheets less than 75 mm or greater than 2500 mm, or with effective bearing temperatures less than -50 °C or greater than 70 °C are outside the scope of this ETA. Effective bearing temperatures above 48 °C shall be limited to short periods as due to climate temperature changes. If composite material is used in guides the maximum effective bearing temperature is limited to 48 °C. Spherical and cylindrical bearings with an included angle $2\vartheta > 60^\circ$ and $2\vartheta > 75^\circ$ respectively are beyond the scope of this ETA (see figure 1).

As an alternative to austenitic steel or hard chrome the sliding alloy MSA[®] may be used as curved mating surface.

Additionally for effective bearing temperatures between -50 °C and 48 °C the sliding coating system MSC[®] may be used as an alternative to austenitic steel in guides, if the MAURER MSM[®] Spherical or cylindrical Bearing shall be used for buildings or equivalent types of structure, where the accumulated sliding path is not greater than 200 m per year. The proven corrosivity class is "high" in accordance with EN ISO 12944-1:1998 and the corrosivity category is C4 in accordance with EN ISO 12944-2:1998.

Spherical or cylindrical bearings for use as temporary devices during construction, for example during launching of the super-structure, are also outside the scope of this ETA.

1.2 Intended use

MAURER MSM[®] Spherical and Cylindrical Bearings are intended to be used for the support of bridges or building works in accordance with the scope of EN 1337-1:2000.

MAURER MSM[®] Spherical and Cylindrical Bearings are suitable for all types of structures but especially for non-rigid structures with relatively large and frequent displacements caused by variable loads, next for superstructures that induce fast sliding displacements in bearings, e.g. in bridges for the high speed railways, as well as for regions with continuously low and/or high temperatures. Spherical and cylindrical parts made of sliding alloy MSA[®] are highly corrosion resistant.

MAURER MSM[®] Spherical and Cylindrical Bearings are mainly used in concrete, steel and composite structures.

The provisions made in this European technical approval are based on an assumed working life of the MAURER MSM[®] Spherical or Cylindrical Bearing of 50 years. The assumed working life of the bearing is reduced to 10 years if composite material is used in guides.

2 Characteristics of product and methods of verification

2.1 Characteristics of product

2.1.1 General

MAURER MSM[®] Spherical Bearings shall permit rotational movements about any axis and MAURER MSM[®] Cylindrical Bearings shall permit rotational movements about one axis. They shall be capable of transferring specified forces between superstructure and substructure.

For design the principles given in clause 5 of EN 1337-1:2000 shall be taken into account.

Note 1: The design values of internal forces and moments as well as of movements should be available from a bearing schedule as shown in Annex B of EN 1337-1:2000

Note 2: In addition to the specific clauses relating to dangerous substances contained in this European Technical Approval, there may be other requirements applicable to the products falling within its scope (e.g. transposed European legislation and national laws, regulations and administrative provisions). In order to meet the provisions of the Construction Products Directive, these requirements need also to be complied with, when and where they apply.

2.1.2 Material combinations

The permissible material combinations for sliding elements are given in Table 1. Only one combination shall be used in a sliding surface. The sliding surface shall be lubricated in accordance with 2.1.8 and 4.1.

Table 1: Permissible combination of materials for permanent applications as sliding surfaces for MAURER MSM[®] spherical or cylindrical bearings

| Plane surface ¹⁾ | | Curved surface | | Guides | |
|--|------------------|--------------------------|------------------|----------------------------|------------------|
| dimpled MSM [®] | austenitic steel | dimpled MSM [®] | austenitic steel | undimpled MSM [®] | austenitic steel |
| | | | hard chromium | | CM1 |
| | | | MSA [®] | CM2 | austenitic steel |
| ¹⁾ The sliding surface may be subdivided in two restrained parts above and below the rotation element permitting in total the design movement, see the example in Fig. A.7 of Annex A. ²⁾ To be used only if the MAURER MSM [®] Spherical or Cylindrical Bearing shall be used for buildings or equivalent types of structure, where the accumulated sliding path is not greater than 200 m per year | | | | | |

2.1.3 MSM[®] sheets

The composition of the material is confidential⁷.

The curved MSM[®] sheet may be attached to either the convex or the concave backing plate. The required geometrical characteristics of MSM[®] sheets are given in Annex B.

2.1.4 Composite material

As an alternative to MSM[®] for strips in guides the composite material of type CM1 and CM2 acc. EN 1337-2:2004, Section 5.3 may be used.

2.1.5 Austenitic steel

Stainless steel shall be in accordance with EN 10088-4:2009 (EN 1337-2:2004, clause 5.4)

2.1.6 Hard chromium plated surfaces

Hard chromium plated surfaces shall be in accordance with EN 1337-2:2004, clause 5.5

2.1.7 Ferrous materials for backing plates

Ferrous materials for backing plates shall be in accordance with EN 1337-2:2004, clause 5.6.

2.1.8 Lubricant

Silicon grease according to EN 1337-2:2004, clause 5.8 shall be used as lubricant for sliding surfaces.

2.1.9 Adhesive for bonding austenitic steel sheets

Note: The main function of the adhesive is to join austenitic steel sheets to the backing plate in such a way that shear is transmitted without relative movement.

The adhesive shall be in accordance with clause 5.9 and Annex J of EN 1337-2:2004.

2.1.10 Sliding alloy MSA[®]

Sliding alloy MSA[®] with special surface treatment may be used as an alternative to steel for spherical and cylindrical backing plates in accordance with section 2.2.6. The material characteristics and surface treatments of the sliding alloy MSA[®] are confidential⁸.

2.1.11 Sliding coating MSC[®]

Sliding coating MSC[®] may be used as mating surface as an alternative to austenitic steel. The material, layer and surface characteristics of the sliding coating MSC[®] are confidential⁸.

2.2 Methods of verification

2.2.1 General

For basic design features clause 7 of EN 1337-1:2000 applies.

2.2.2 Design verification for sliding surfaces

Note 1: Excessive pressure may cause loss of the sliding function and this may lead to structural failure or states close to structural failure. Therefore this condition is considered as ultimate limit state.

⁷ The technical documentation to this European technical approval is deposited with Deutsches Institut für Bautechnik and, as far as relevant for the task of the approved bodies involved in the attestation of conformity procedure is handed over to the approved bodies.

⁸ The technical documentation to this European technical approval is deposited with Deutsches Institut für Bautechnik and, as far as relevant for the task of the approved bodies involved in the attestation of conformity procedure is handed over to the approved bodies.

When dimensioning sliding surfaces, all the internal forces and moments due to actions and frictional resistance shall be considered. The design values of the action to be taken into account shall be determined in accordance with the basic design criteria given in EN 1337-1:2000.

Deformation of sliding materials shall not be used to accommodate rotations except as permitted in 2.2.3.

The following conditions shall be verified under a fundamental combination of actions:

$$N_{Sd} \leq \frac{f_k}{\gamma_m} \cdot A_r = \frac{f_k}{\gamma_m} \cdot \lambda \cdot A$$

where

N_{Sd} is the design axial force at ultimate limit state

f_k is the characteristic value of compressive strength acc. Table 2

γ_m partial safety factor for materials in accordance with EN 1990:2002

A is the contact area of the flat sliding surface or the projection of curved surfaces

λ is a coefficient given in Annex C

A_r is the reduced contact area of the sliding surface whose centroid is the point through which N_{Sd} acts with the total eccentricity e_t , which is caused by both mechanical and geometrical effects. A_r shall be calculated on the basis of the theory of plasticity assuming a rectangular stress block (see Annex C). For guides eccentricity can be neglected.

Note 2: The γ_m value should be given us NDP (national determined parameter). In absence of NDP the recommended value is $\gamma_m = 1.4$.

For MSM[®] sheets with the smallest dimension "L", "a" or "b" in accordance with clause B.1 of Annex B larger or equal 100 mm, contact areas A and A_r shall be taken as the gross area without deduction for the area of the dimples. For sheets with "L", "a" or "b" smaller than 100 mm the area of the dimples shall be deducted from the gross area.

The characteristic compressive strengths of MSM[®] are given in Table 2 and are valid for effective bearing temperatures up to 70°C. For bearings exposed to a maximum effective bearing temperature in excess of 35 °C and up to 70° C the characteristic compressive strength shall be estimated by linear interpolation of the values given in table 2.

Table 2: Characteristic compressive strength of MSM[®]

| Effective bearing temperature [°C] | ≤ 35 °C | 48°C | 70°C |
|--|---|---------|--------|
| Sliding surface | Characteristic compressive strength f_k | | |
| Main sliding surface Dead loads and variable loads | 180 MPa | 135 MPa | 90 MPa |
| Guides Variable loads | | | |
| Guides Dead loads Effects of temperature, shrinkage and creep | 60 MPa | 45 MPa | 30 MPa |

For guides with composite material see 6.3 and 6.6 of EN 1337-2:2004.

For the purpose of compressive stress verification the curved sliding surface shall be replaced by its projection on a plane surface as shown in figure 1.

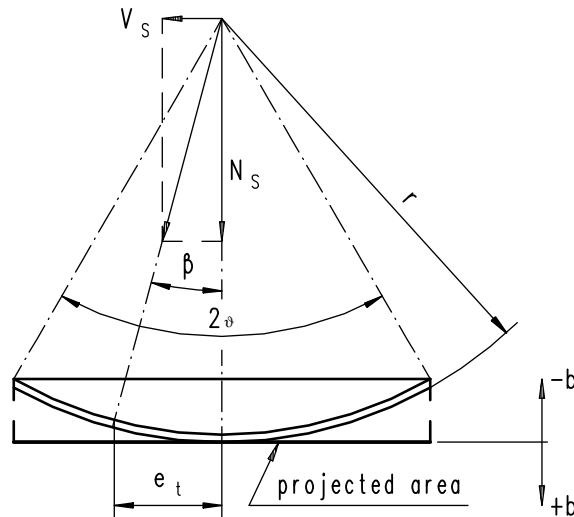

Figure 1 -Verification scheme for the curved sliding surface (example)

Internal forces and moments acting on the curved sliding surface due to frictional resistance, externally applied horizontal loads and the rotated condition of the bearing shall be taken into account when determining the resulting total eccentricity e_t of the axial force N_s .

Secondary effects due to the action of the restraints shall be also considered.

Note 3: In Annex D of this ETA formulae are given for the evaluation of the eccentricities in the most common cases

Note 4: Separation of the sliding surfaces may lead to wear due to contamination and increased deformation due to lack of confinement of the MSM[®]-plate. As this could endanger long term fitness for use, the achievement of the edge pressure $\sigma_{MSM} = 0$ is considered as serviceability limit state.

With the exception of guides, it shall be verified that $\sigma_{MSM} \geq 0$ under a characteristic combination of actions. In doing so the sliding material shall be assumed to be linear elastic and the backing plates shall be deemed to be rigid. The condition $\sigma_{MSM} \geq 0$ is satisfied when the total eccentricity e_t falls within the kernel of the projected area.

For circular sheets this condition is satisfied when:

$$e_t \leq \frac{L}{8}$$

where

L diameter see annex B

2.2.3 Guides

Guides may be used for resisting horizontal forces V_d due to variable and permanent actions. Depending on the bearing construction, the guides may be arranged externally or centrally. The sliding materials shall be fixed on keys and the keyways in the backing plates.

Clearance c between sliding components in unused condition shall meet the following condition:

$$c \leq 1.0 \text{ mm} + \frac{L[\text{mm}]}{1000} \leq 2.5 \text{ mm}$$

A typical example of the attachment of guides is shown in figure A.1 of Annex A. In the design of the connection at ultimate limit state in accordance with EN 1993-1-1:2005, the effects of horizontal force V_d , its induced moment and the friction forces shall be considered.

The maximum clearance in guides may be reduced due to adjustable guides. For this purpose high tensile screws in accordance with EN 1993 shall be used. The main principle of adjustable guides is shown in Fig. A.8 of Annex A.

Where, under predict rotation about a transverse axis the differential deformation of the MSM[®] sheet across its smallest dimension "a" would exceed 0.2 mm, a rotation element shall be included in the backing plate (see figure 1, 3.3 of EN 1337-1:2000). This condition shall be verified for the unfactored characteristic actions. The material combination of this rotation element shall be designed in accordance with the requirements of the mating surfaces of guides given in this ETA or pot to piston contact surfaces given in EN 1337-5:2005.

2.2.4 Restraining rings

The free MAURER MSM[®] spherical or cylindrical bearing may be fixed by a steel restraining ring. For design and verification, the design rules for pot and piston of pot bearings given in clause 6 of EN-337-5:2005 shall be followed.

2.2.5 Austenitic steel sheets

The minimum thickness of the austenitic steel sheet shall be in accordance with Table 3.

Care shall be taken to ensure that the austenitic steel sheet is fully in contact with the backing plate over the area which will be in contact with the MSM[®] sheet. When attaching the austenitic steel sheet by screwing, counterpunched screwing and rivetting, corrosion resistant fasteners compatible with the austenitic steel sheet shall be used for securing its edges. They shall be provided at all corners and along the edges outside the area of contact with the MSM[®] sheet with the maximum spacing listed in Table 4.

Table 3: Thickness and methods of attachment of austenitic steel sheets.

| Type of surface | Method of attachment | Thickness t [mm] |
|-----------------|------------------------------|--------------------|
| flat | full surface bonding | 1.5 |
| | continuous fillet weld | ≥ 1.5 |
| | counterpunched screwing | ≥ 1.5 |
| | screwing, rivetting | ≥ 2.5 |
| spherical | full surface bonding | ≥ 2.5 |
| | continuous fillet weld | ≥ 2.5 |
| | recessed in concave surfaces | ≥ 2.5 |
| cylindrical | full surface bonding | ≥ 1.5 |
| | continuous fillet weld | ≥ 1.5 |
| | recessed in concave surfaces | ≥ 2.5 |

Table 4: Maximum fastener spacing for attachment of austenitic steel sheets by screwing, counterpunched screwing and rivetting.

| Austenitic steel sheet thickness [mm] | Maximum fasteners spacing [mm] |
|---------------------------------------|--------------------------------|
| 1.5 | 150 |
| 2.0 | 300 |
| 2.5 | 450 |
| 3.0 | 600 |

2.2.6 Backing plates

The MSM[®] and the mating sliding materials shall be supported by metal plates (backing plates) with plane or curved surfaces. The geometrical conditions are given in Annex E. The design of the backing plates shall take into account the following:

- verification at ultimate limit state when internal forces and moments from lateral actions are to be considered in addition to the effects from deformation as per hereafter,
- any cross section reduction (for example due to keyway and the attachment bolts),
- deformations as per hereafter,
- the required stiffness for transport and installation as per hereafter,
- distribution of forces to the adjacent structural members as per hereafter.

Note: If the deformations (see figure 2) exceed the values Δw given below, unacceptably small clearance between the adjacent backing plates and higher wear will occur. As this could endanger the long term fitness for use of the sliding element, this condition is considered serviceability limit state.

The deformation Δw (see figure 2) shall meet the following condition:

$$\Delta w \leq h \left(0.45 - 1.708k \sqrt{h/L} \right) \quad \text{with} \quad 0 \leq 1.708k \leq 1.0 \quad \text{and} \quad k = \frac{\sigma_{\text{MSM}} [\text{MPa}] - 45}{78.5}$$

where is

L, h see Annex B

σ_{MSM} average pressure in the sliding surface under the characteristic combination of action

k stiffness coefficient depends on sliding material

The stress in the backing plate induced by the respective deformation shall not exceed the elastic limit in order to avoid permanent deformations. The theoretical model for verification of the above requirements (deformation Δw and yield strength) shall include the effects of all the bearing components which have a significant influence on these deformations including the adjacent structural members and their short and long-term properties.

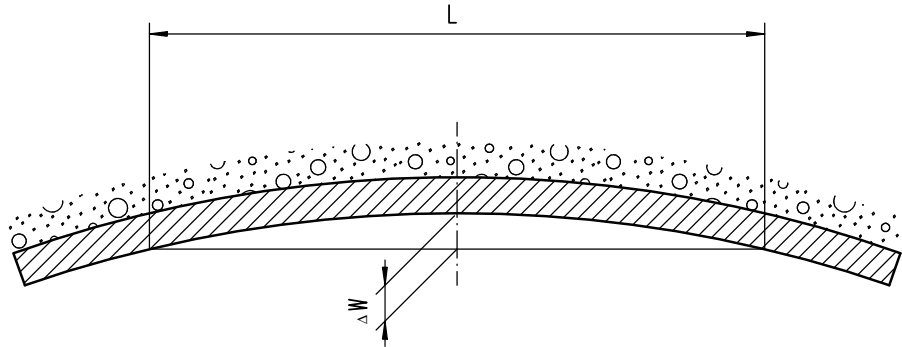

Figure 2 - Deformations of backing plates.

For steel and concrete, the design values of material properties in accordance with EN 1993-1-1:2005 and EN 1992-1-1:2004 respectively apply.

In this model the following assumptions shall be made:

- central load
- notional design modulus of elasticity of MSM[®] = 0.9 GPa
- the total thickness t_{MSM} of MSM[®] sheet
- notional design Poisson's ratio of MSM[®] = 0.44
- in the case of adjacent structural members of massive construction: linear reduction of the elastic modulus of concrete or mortar from the edge to the center of the backing plate from 100% to 80%.

A suitable method for calculating deformation Δw for common materials is given in E.5 of Annex E.

When using the method given in Annex E elastic limit verification of the backing plate is not required if:

- the condition for the deformation Δw is met;
- the concrete strength class is at least C 25/30 in accordance with EN 206-1:2000;
- and the steel grade is at least S 355 in accordance with EN 10025-2:2004.

The above also applies when using lower concrete strength classes and/or steel grades, provided the deformation limit values calculated as above are reduced by a factor of:

0.90 when using concrete strength class C 20/25

0.67 when using steel S 235

0.60 when using both concrete C 20/25 with steel S 235.

Note: The above is not the only criterion to be considered in determining the relative deformation Δw . Particular attention shall be paid to loadings during construction (e.g. when large backing plates are not propped during concrete casting).

The calculation of the relative deformation of the backing plate with convex surface shall be omitted.

Square or rectangular plates shall be idealised to circular plates of diameter

$$d_b = 1.13 a_b$$

where a_b is the side of the square plate or the minor side of the rectangular plate.

The thickness of the backing plate shall be:

$$t_b \geq 0.04 \cdot \sqrt{a_b^2 + b_b^2}$$

or 10 mm, whichever is greater, where:

a_b is the minor side of backing plate and

b_b is the major side of backing plate.

2.2.7 Sliding behaviour

The following coefficients of friction μ_{\max} shall be used for verification of the bearing and the structure in which it is incorporated. These values shall not be applied in the presence of high dynamic actions which may occur for instance in seismic zones. The effects of friction shall not be used to relieve the effects of externally applied horizontal loads. The average pressure σ_{MSM} shall be estimated using the gross contact area, i. e. neglecting the deduction of the area of the dimples given in clause 2.2.2.

(a) Coefficient of friction at low temperatures

For sliding elements combined with dimpled and lubricated MSM[®] sheets used in zones where the minimum effective bearing temperature doesn't fall below -35°C, the coefficient of friction μ_{\max} is determined as a function of the average pressure σ_{MSM} [MPa], as follows:

$$0.020 \leq \mu_{\max} = \frac{1.6}{15 + \sigma_{\text{MSM}}} \leq 0.08$$

For guides the coefficient of friction shall be considered to be independent of contact pressure. The coefficient of friction $\mu_{\max} = 0.10$ shall be used.

(b) Coefficient of friction at very low temperatures

For sliding elements combined with dimpled and lubricated MSM[®] sheets used in zones where the minimum effective bearing temperature does fall below -35 °C (down to -50 °C), the coefficient of friction μ_{\max} is determined as a function of the average pressure σ_{MSM} [MPa], as follows:

$$0.027 \leq \mu_{\max} = \frac{2.8}{30 + \sigma_{\text{MSM}}} \leq 0.08$$

For guides the coefficient of friction shall be considered to be independent of contact pressure. The coefficient of friction $\mu_{\max} = 0.12$ shall be used.

(c) Coefficient of friction at moderate low temperatures

For sliding elements combined with dimpled and lubricated MSM[®] sheets used in zones where the minimum effective bearing temperature doesn't fall below -5 °C, the coefficient of friction μ_{\max} is determined as a function of the average pressure σ_{MSM} [MPa], as follows:

$$0.015 \leq \mu_{\max} = \frac{1.2}{15 + \sigma_{\text{MSM}}} \leq 0.06$$

For guides the coefficient of friction shall be considered to be independent of contact pressure. The coefficient of friction $\mu_{\max} = 0.07$ shall be used.

For composite materials see 6.7 of EN 1337-2:2004.

2.2.8 Rotation capability

The sliding surfaces shall meet the requirements given in this ETA.

Under the fundamental combination of actions it shall be shown that

- the metallic surfacing mating with the MSM[®] material is so proportioned that it completely covers the MSM[®] sheet,
- there is no contact between the upper and the lower part of the bearing or any other metallic component (see EN 1337-1:2000, Annex A).

For the verification of the above conditions the increase of rotations, specified in clause 5.4 of EN 1337-1:2000, shall be taken into account.

For rotations about a transverse axis of guides see 2.2.3.

For guides with composite material see 6.3 of EN 1337-2:2004.

For MAURER MSM[®] Spherical Bearings with external guides the rotation capability around the vertical axis may be increased using a guide ring, see Fig. A.9 of Annex A. The contact surfaces of this guide ring shall be designed in accordance with the requirements given in clause 2.2.4.

2.2.9 Displacement capacity

By taking into account of the increased movements according to 5.4 in EN 1337-1:2000, it shall be verified under the fundamental combination of actions that the austenitic steel sheets are designed such, that with maximum displacement of the sliding element they completely cover the MSM[®] and the CM sheets.

Note: The assumed working life of 50 years is based on the assumptions of a maximum accumulated sliding path of $c \cdot 50\,000$ m and a maximum of 15 mm/sec of average sliding speed in the main sliding surfaces (for PTFE acc. EN 1337-2:2004 $c \cdot 10\,000$ m and 2 mm/sec), where c ($c \geq 1$) is a factor to correct the difference between the constant amplitude slide path used in the approval tests and the variable amplitude movements which occur due to traffic. If the sliding coating system MSC[®] is used as mating surface in guides, the accumulated sliding path shall not be greater than 200 m per year.

3 Evaluation and attestation of conformity and CE marking

3.1 System of attestation of conformity

According to the communication of the European Commission⁹ the system 1 of attestation of conformity applies.

This system of attestation of conformity is defined as follows:

Certification of the conformity of the product by an approved certification body on the basis of:

- (a) Tasks for the manufacturer:
- (1) factory production control;
 - (2) further testing of samples taken at the factory by the manufacturer in accordance with a prescribed test plan;

⁹ Letter of the European Commission of 24/10/1995 to EOTA

- (b) Tasks for the approved body:
- (3) initial type testing of the product;
 - (4) initial inspection of factory and of factory production control;
 - (5) continuous surveillance, assessment and approval of factory production control.

Note: Approved bodies are also referred to as "notified bodies".

3.2 Responsibilities

3.2.1 Tasks of the manufacturer

3.2.1.1 Factory production control

The manufacturer shall exercise permanent internal control of production. All the elements, requirements and provisions adopted by the manufacturer shall be documented in a systematic manner in the form of written policies and procedures, including records of results performed. This production control system shall insure that the product is in conformity with this European technical approval.

The manufacturer may only use constituent parts stated in the technical documentation of this European technical approval.

The factory production control shall be in accordance with the "control plan" relating to this European technical approval which is part of the technical documentation of this European technical approval. The "control plan" is laid down in the context of the factory production control system operated by the manufacturer and deposited at Deutsches Institut für Bautechnik.¹⁰

The results of factory production control shall be recorded and evaluated in accordance with the provisions of the "control plan".

3.2.1.2 Other tasks of manufacturer

The manufacturer shall, on the basis of a contract, involve a body which is approved for the tasks referred to in section 3.1 in the field of "spherical and cylindrical bearings with special sliding material" in order to undertake the actions laid down in section 3.2.2. For this purpose, the "control plan" referred to in sections 3.2.1.1 and 3.2.2 shall be handed over by the manufacturer to the approved body involved.

The manufacturer shall make a declaration of conformity, stating that the construction product is in conformity with the provisions of this European technical approval.

3.2.2 Tasks of approved bodies

The approved body shall perform the

- initial type-testing of the product,
- initial inspection of factory and of factory production control,
- continuous surveillance, assessment and approval of factory production control,
- single acceptance or at least 5 % per lot of production for bearings with a diameter L of the special sliding material in the main sliding surface larger than 1500 mm,,

in accordance with the provisions laid down in the "control plan relating to this European technical approval.

The approved body shall retain the essential points of its actions referred to above and state the results obtained and conclusions drawn in a written report.

¹⁰

The "control plan" is a confidential part of the documentation of the European technical approval, but not published together with the ETA and only handed over to the approved body involved in the procedure of attestation of conformity. See section 3.2.2.

The approved certification body involved by the manufacturer shall issue an EC certificate of conformity of the product stating the conformity with the provisions of this European technical approval.

In cases where the provisions of the European technical approval and its "control plan" are no longer fulfilled the certification body shall withdraw the certificate of conformity and inform Deutsches Institut für Bautechnik without delay.

3.3 CE marking

Regardless of the requirements stated in 7.3 of EN 1337-1:2000, the CE marking shall be affixed on the bearing so that it will be visible throughout the life time of the bearing. The full information given below should be in the relevant accompanying documents. The letters "CE" shall be followed by the identification number of the approved certification body, where relevant, and be accompanied by the following additional information:

- the name and address of the producer (legal entity responsible for the manufacturer),
- the last two digits of the year in which the CE marking was affixed,
- the number of the EC certificate of conformity for the product,
- the number of the European Technical Approval,
- description of the product,
- geometrical data,
- material properties,
- characteristics and declared performances of the product on the basis of the ETA,
- dangerous substances.

4 Assumptions under which the fitness of the product for the intended use was favourably assessed

4.1 Manufacturing

The manufacturing tolerances for backing plates are given in Annex E.

In the case of plane backing plates the MSM[®] sheets shall be confined in accordance with Annex B. In addition, MSM[®] sheets for guides shall be bonded to assist assembling.

Where the dimples in MSM[®] sheets are produced by hot pressing the temperature during the pressing process shall not exceed the melting temperature of MSM[®].

Composite materials shall be attached by bonding supplemented by mechanical attachment outside the sliding surface.

Methods of attachment and respective dimensions of austenitic steel sheets are given in 2.2.5.

Note: General requirements for corrosion protection are given in EN 1337-9:1997. This subclause gives additional requirements for sliding elements.

Where the austenitic steel sheet is attached by full area bonding or by continuous fillet weld, provided the area covered by the austenitic steel sheet is free from rust and rust inducing contaminants, no further treatment of the backing plate behind the austenitic steel sheet is required.

Where the austenitic steel sheet is attached by screwing, counterpunched screwing or rivetting the full corrosion protection system shall be applied to the backing plate behind the austenitic steel sheet.

When bonding the austenitic steel sheet, an adhesive with characteristics given in 2.1.9 shall be used. Preparation of the adherents shall be in accordance with adhesive manufacturer's recommendations. There shall be no voids in the adhesive layer and a fillet of adhesive shall be formed around the complete periphery of the austenitic sheet during the bonding process. The flatness as required in E.3 of Annex E shall be achieved after bonding.

Areas of the backing plate behind the MSM[®] and recessed austenitic steel sheets shall be protected by one coat of primer (dry film thickness 20 µm to 100 µm).

Provision against contamination of the sliding surface shall be made by suitable devices. Such protection devices shall be easily removable for the purpose of inspection.

The hard chromium surface shall be visually inspected for cracks and pores. In addition to the visual inspection, the absence of defects shall be verified by a Ferroxy test in accordance with Annex E of EN 1337-2:2004. If the visual inspection of the surfaces reveals any potential defects, the Ferroxy test shall be applied over the entire affected area. If any defects are detected by Ferroxy test, the hard chrome plating shall be rejected.

Since hard chromium plating is not resistant to chlorides in acid solution or to fluorines and can be damaged by air borne particles, such as occur in industrial environment, special provision shall be made to protect the surfaces in those conditions.

Prior to assembly the sliding surfaces shall be cleaned.

Spherical or cylindrical elements made of MSA[®] do not need an additional corrosion protection.

After cleaning and prior to assembly, the dimpled MSM[®] sheet shall be lubricated with lubricant according to 2.1.8 in a way which ensures that all the dimples are filled. For guides the sliding material shall be initially lubricated by rubbing a small amount of lubricant into the surface and wiping off the remainder.

During assembly process, provisions shall be taken against contamination of lubricated surfaces.

The European technical approval is issued for the product on the basis of agreed data/information, deposited with Deutsches Institut für Bautechnik, which identifies the product that has been assessed and judged. Changes to the product or production process, which could result in this deposited data/information being incorrect, should be notified to Deutsches Institut für Bautechnik before the changes are introduced. Deutsches Institut für Bautechnik will decide whether or not such changes affect the ETA and consequently the validity of the CE marking on the basis of the ETA and if so whether further assessment or alterations to the ETA shall be necessary.

4.2 Installation

In order to ensure bearing alignment in accordance with EN 1337-11:1997 a reference surface or other suitable device shall be installed on the sliding element.

The deviation from parallel of the reference surface with respect to the plane sliding surface shall not exceed 1‰.

After installation and completion of the superstructure, the deviation of the sliding element from the specified alignment shall not exceed 3‰ in accordance with 6.5 of EN 1337-11:1997.

5 Indications to the manufacturer

5.1 Packaging, transport and storage

The stipulations according to 7.4 of EN 1337-1:2000 and EN 1337-11:1997 apply.

The bearing shall be labelled by the manufacturer with the conformity mark (CE mark). The mark may only be applied when the prerequisites, in accordance with section 3, concerning the proof of conformity are fulfilled.

The bearing is additionally to be provided, in accordance with EN 1337-1:2000 with a marking label which, if applicable, is possibly to be fixed in position on the side of the movement indicator.

5.2 Use, maintenance, repair

For the inspection and maintenance of Maurer MSM[®] Spherical and Cylindrical Bearings see 7.5 of EN 1337-1:2000 and EN 1337-10:2003. For the resetting and replacement 7.6 of EN 1337-1:2000 apply. On installing the bearing, the stipulations of EN 1337-11:1997 are to be observed.

The bearing is to be adjusted horizontally in accordance with the bearing setting plan on the measuring plane, in accordance with section 4.2, using measuring equipment with a precision of at least 0.3‰.

After setting the mortar joints, the deviation in inclination established may not exceed 3‰ on the measuring plane.

During inspection of items listed in EN 1337-10:2003 the following value shall be checked:

- Protrusion h : ≥ 1 mm. (see Annex B, figure B.1)

If the protrusion h of the MSM[®] sheet is found to be less than 1 mm, or a bulging of the austenitic sheet exceeds the measured protrusion in its vicinity, the sliding element is still deemed to be serviceable but more frequent inspections shall be conducted.

If the protrusion of the MSM[®] sheet is reduced to zero, the sliding element shall no longer be considered capable of accommodating movement.

Uwe Bender
Head of Department

beglaubigt:
Hoppe

Annex A

Description of the product and its intended use

MAURER MSM® Spherical or Cylindrical Bearings (example)

guided spherical bearing
(movable unidirectional)

free spherical bearing
(movable multidirectional)

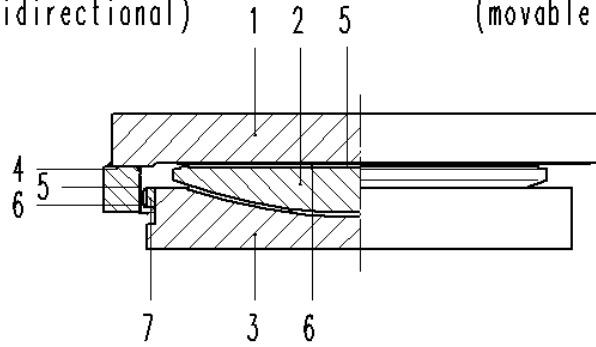

guided cylindrical bearing
(movable unidirectional)

free cylindrical bearing
(movable multidirectional)

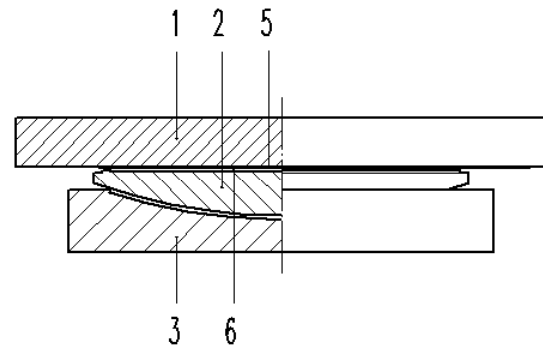
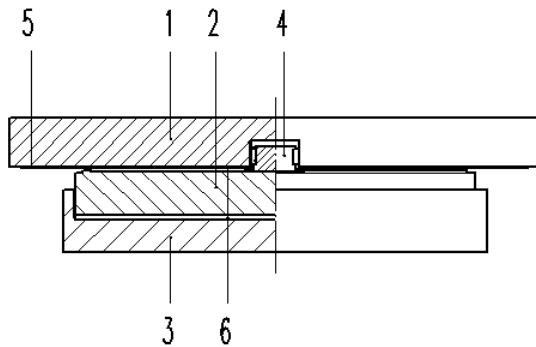

- 1 Sliding plate
- 2 Rotational element (convex plate)
- 3 Bottom plate (concave backing plate)
- 4 Guiding key

- 5 Austenitic steel sheet
- 6 MSM®- sheet or strip
- 7 Rocker strip

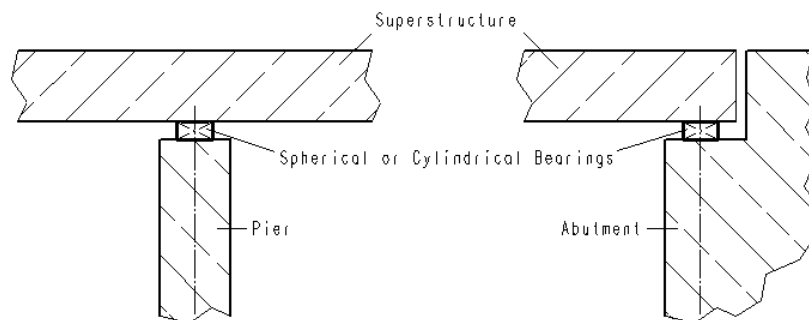

Figure A.1 - Assembly of a guided and free movable spherical or cylindrical bearing with MSM® and its intended use

English translation prepared by DIBt

MAURER MSM[®] spherical or cylindrical bearings consist of a backing plate with a convex spherical or cylindrical surface (rotational element) and a backing plate with a concave spherical or cylindrical surface between which a MSM[®] sheet and the mating material form a curved sliding surface (see Figure A.2 and A.4).

MAURER MSM[®] spherical or cylindrical bearings are also used in combination with flat sliding elements and guides to form free and guided bearings (see figures A.3 and A.5 a) to c)). MAURER MSM[®] spherical or cylindrical bearings combined with a flat sliding element can be used together with a restraining ring to form fixed bearings (see Figure A.3 d)).

Note: Numbers in brackets in figures A.2 and A.3 refer to the examples shown in figure 1 of EN 1337-1:2000.

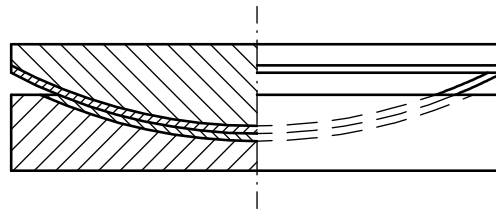

Fixed by sliding surface (3.2).

Figure A.2 - MAURER MSM[®] spherical bearings

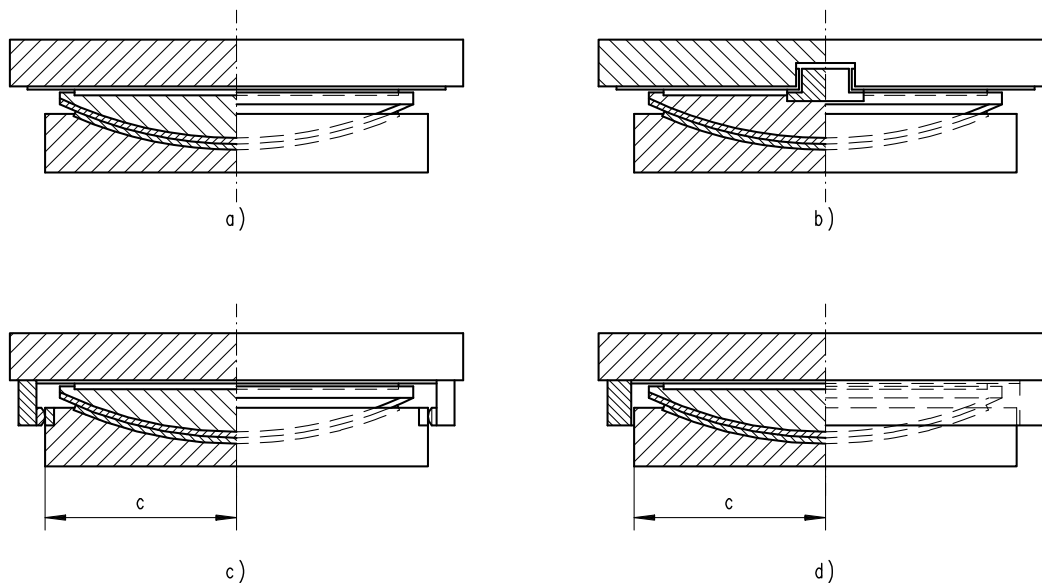

Key

- a) free for displacements in any direction (3.5)
- b) guided by an internal guide for displacements in one direction (3.4)
- c) guided by external guides in one direction (3.3)
- d) fixed by a restraining ring (3.1)

Figure A.3 - MAURER MSM[®] spherical bearings combined with flat sliding element

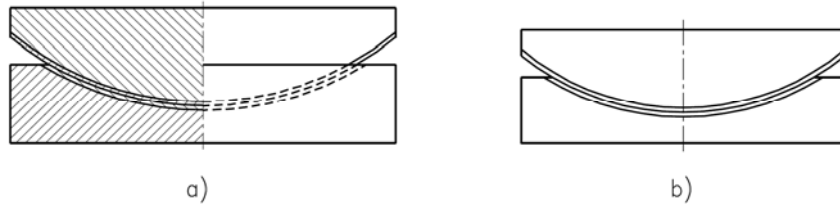

Key

- a) Fixed by end stops and sliding surface (7.1)
- b) Without end stops for displacements in y-direction (7.2)

Figure A.4 — MAURER MSM[®] cylindrical bearings

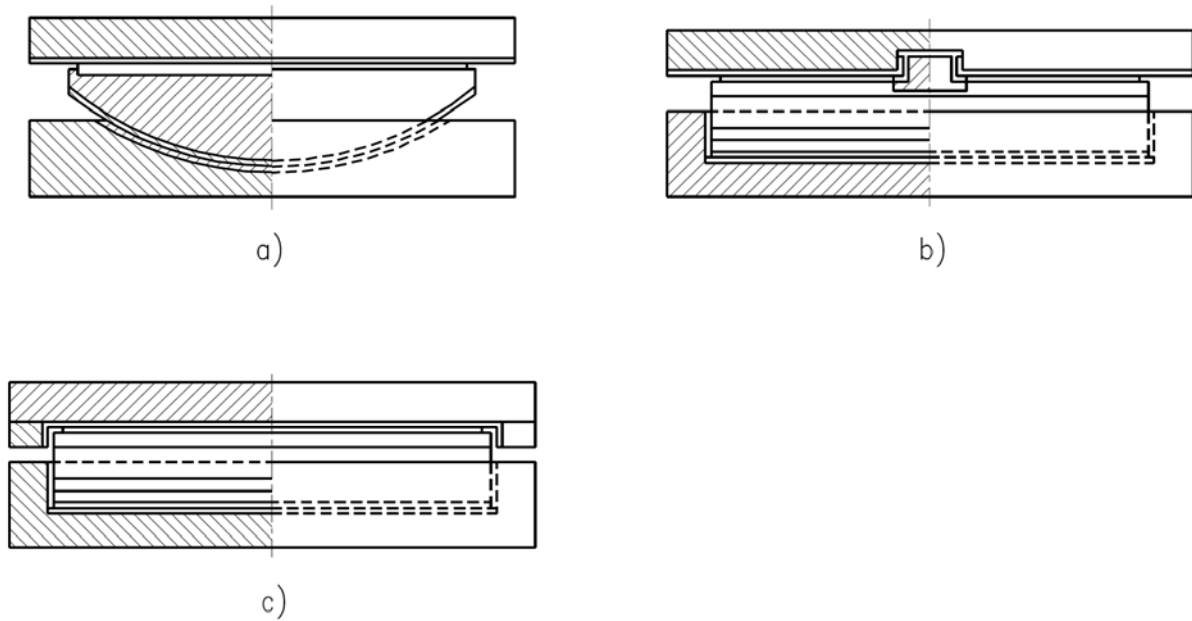

Key

- a) Free for displacements in any direction (7.4)
- b) Guided by an internal guide for displacements in x-direction (7.3)
- c) Guided by external guides for displacements in x-direction

Figure A.5 — MAURER MSM[®] cylindrical bearings combined with flat sliding elements

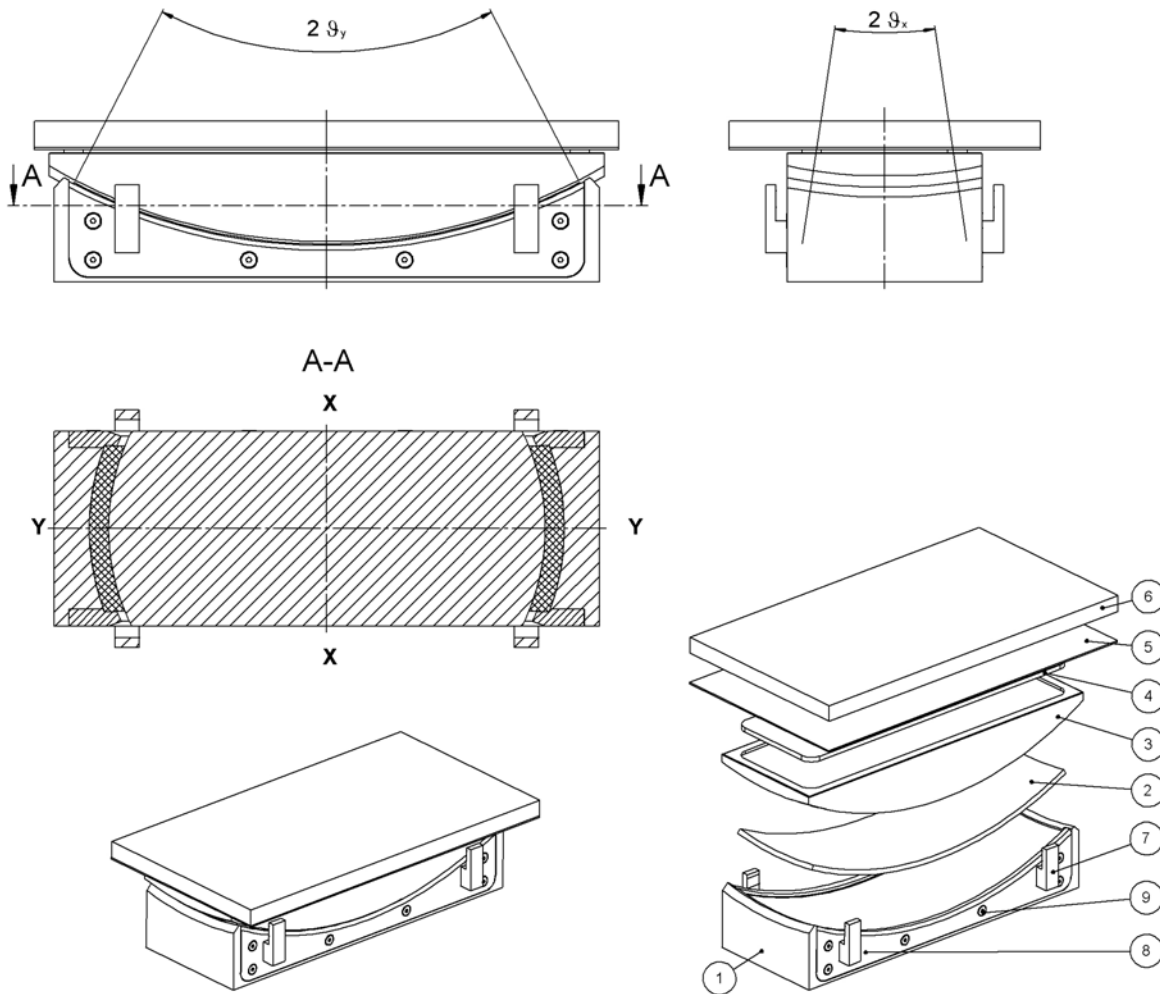

- 1 Lower backing plate
- 2 Curved MSM® sheet
- 3 Segmental spherical part
- 4 Flat MSM® sheet
- 5 Mating surface
- 6 Upper backing plate
- 7 Locking device
- 8 Lateral recess plate
- 9 Screw

Figure A.6 — MAURER MSM® Spherical Segment Bearing (example)

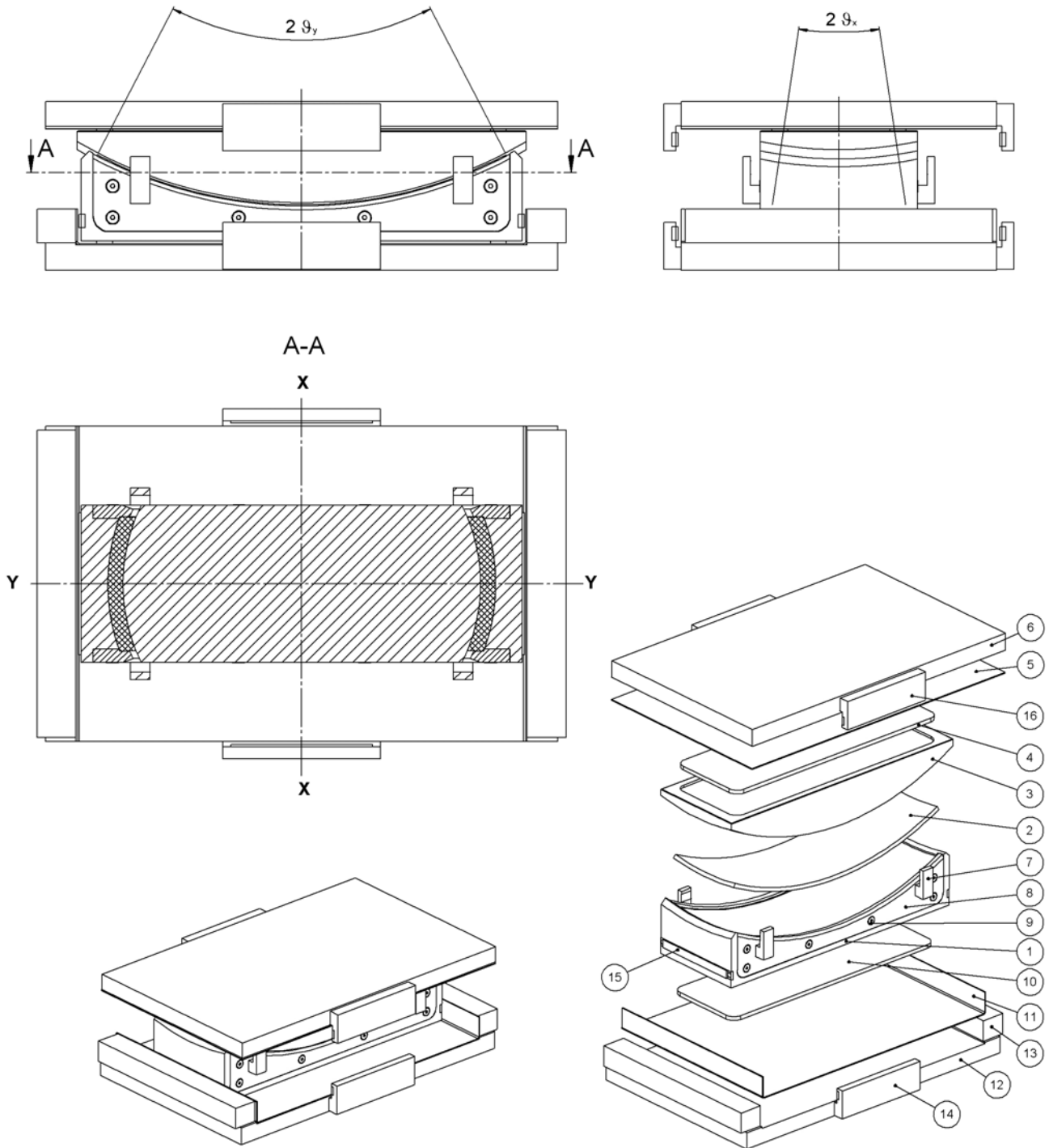

- | | | | |
|---|--------------------------|----|-----------------------|
| 1 | Lower backing plate | 9 | Screw |
| 2 | Curved MSM® sheet | 10 | Lower flat MSM® sheet |
| 3 | Segmental spherical part | 11 | Lower mating surface |
| 4 | Upper flat MSM® sheet | 12 | Lower Sliding plate |
| 5 | Upper mating surface | 13 | Guiding key |
| 6 | Upper sliding plate | 14 | Lower restraint |
| 7 | Locking device | 15 | MSM® strip |
| 8 | Lateral recess plate | 16 | Upper restraint |

Figure A.7 — MAURER MSM® Spherical Segment Bearing with two sliding surfaces (example)

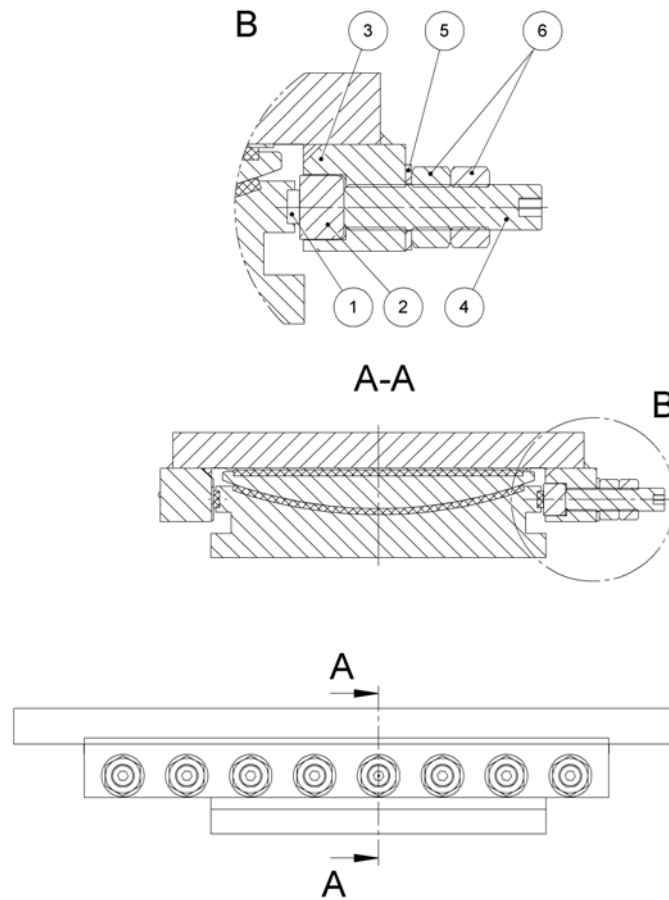

- 1 MSM® Strip in guides
- 2 Austenitic steel bar
- 3 Guiding key
- 4 Threaded bolts
- 5 Washer
- 6 nut, lock nut

Figure A.8 — MAURER MSM® Bearings with adjustable guides (example)

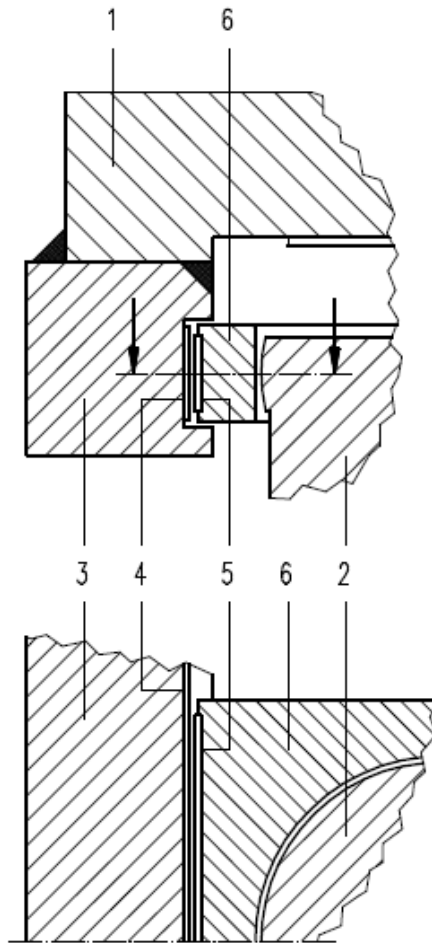

- 1 Sliding plate
- 2 Backing plate
- 3 Guiding key
- 4 Mating surface
- 5 MSM[®] or CM
- 6 Guide ring

Figure A.9 — MAURER MSM[®] Spherical Bearings with guided rotation ring (example)

Annex B

Geometrical characteristics of MSM® sheets

B.1 Details of recess and relief for sliding elements with MSM®

The performance characteristics of MAUER MSM® spherical and cylindrical bearings given in this ETA are valid only for the following geometrical conditions.

For MAURER MSM® spherical bearings the absence of two symmetrical circular segments for not subdivided sheets is permissible, if the limitation for the included angle given in clause 1.1 and the proof of non separation of the sliding surface given in clause 2.2.2 is fulfilled for both the main axes. The main principle of MAURER MSM® spherical segment bearings is shown in Fig. A.6 and A.7 of Annex A.

B.1.1 Recess of MSM® sheets

The MSM® sheets shall be recessed into a backing plate as shown in figure B.1.

Dimensions in millimetres

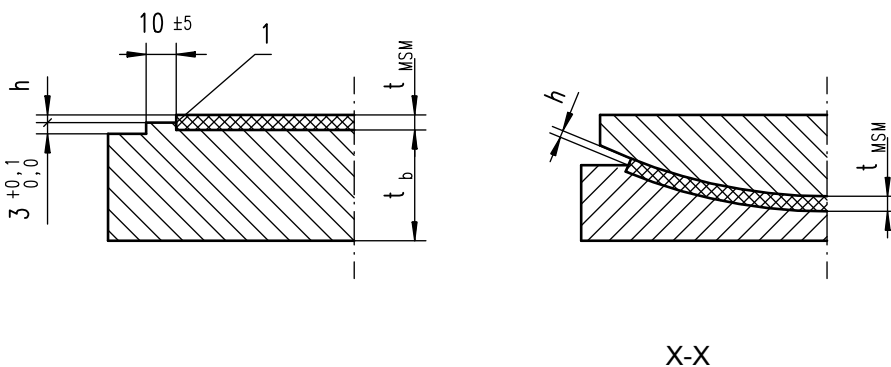

Key

1 Sharp edged

Figure B.1 - Details of MSM® recess and relief

Note : A fixed value for the depth of the relief is given to facilitate the measurement of the MSM® protrusion "h" after installation. For section x-x, see figure B.2 resp. B.3.

The thickness t_{MSM} and protrusion h of the MSM® sheet in the unloaded condition with corrosion protection shall meet the conditions given in Table B.1

Table B.1- Thickness t_{MSM} and protrusion h of the MSM® sheet

| Design values | Flat and curved sliding surfaces | Guides |
|---------------------------|---|------------------------------|
| Thickness t_{MSM} in mm | $2.65 \cdot h \leq t_{MSM} \leq 10.0$; with h in mm | $8.0 \leq t_{MSM} \leq 10.0$ |
| Protrusion h in mm | $h = 2.50 + \frac{L}{3000}$ L diameter of the projected area of the MSM® sheet in mm | $h = 3.0 \pm 0.2$ |

The tolerance on the protrusion h is ± 0.2 mm for L less than or equal to 1200 mm and ± 0.3 mm for L greater than 1200 mm. The protrusion h shall be verified at marked measuring points, where the corrosion protection coating shall not exceed 300 μm . There shall be at least two measuring points, suitably located. The admissible tolerance on thickness t_{MSM} of single MSM® sheets or associated multiple sheets is $\begin{matrix} +0,3 \\ -0,0 \end{matrix}$ mm for sheets with a diameter L less than 1200 mm and $\begin{matrix} +0,4 \\ -0,0 \end{matrix}$ mm for larger sheets.

B.1.2 Flat MSM® sheets

Flat MSM® sheets for the main sliding surface shall be circular and may be sub-divided into a maximum of four identical parts. Further sub-divisions are beyond the scope of this ETA. The smallest dimension "a" shall not be less than 50 mm. The distance between individual MSM® sheets shall not be greater than twice the thickness of the backing plate, of the MSM® or the mating material, whichever is least. Figure B.2 shows some examples of sub-division of flat MSM® sheets.

Dimensions in millimetres

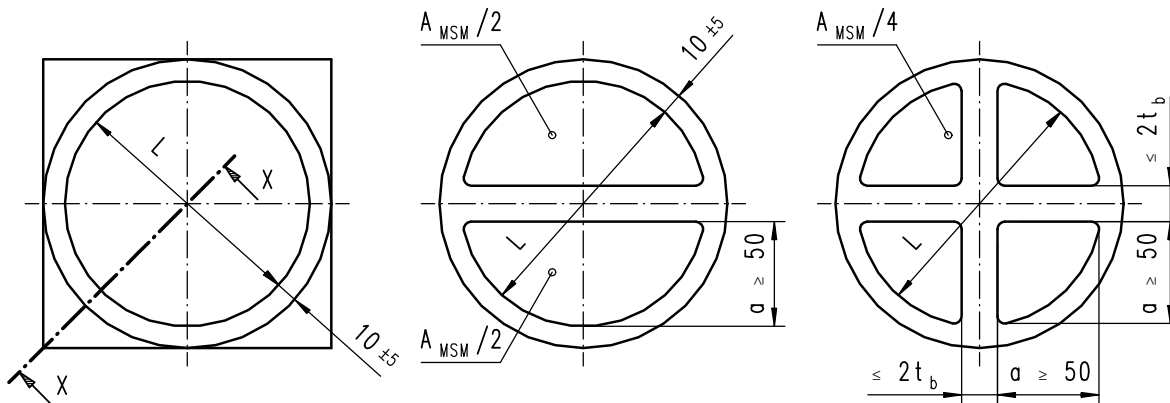

Figure B.2 - Examples of recessed flat MSM[®] configurations

B.1.3 Curved MSM[®] sheets

Curved MSM[®] sheets for spherical sliding surfaces shall be circular and may be subdivided into a disc and an annulus. The disc, if subdivided, shall not be less than 1000 mm or $2/3 L$ in diameter, whichever is larger. The width of the annulus shall not be less than 50 mm. The annulus may be divided into equal segments. Both the disc and the annulus may be retained in recesses. The separating ring of the backing plate shall not be more than 10 mm wide. Figure B.3 shows the configurations of curved MSM[®] sheets for spherical sliding surfaces.

Dimensions in millimeters

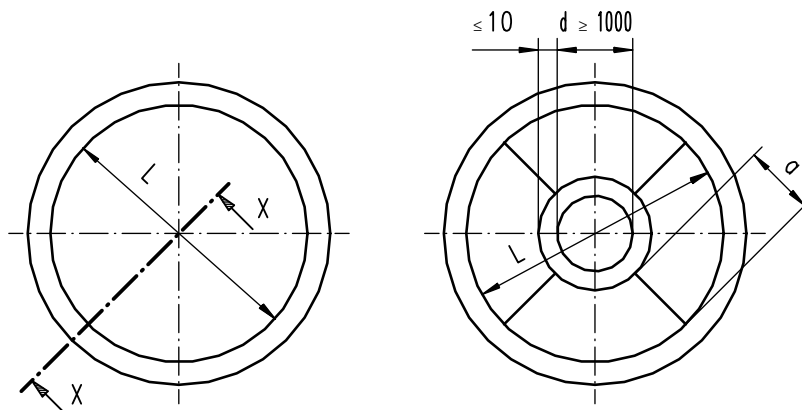

Figure B.3 - Subdivision of recessed MSM[®] sheets for spherical sliding surfaces

Curved MSM[®] sheets for cylindrical sliding surfaces shall be rectangular and may be subdivided into a maximum of two identical parts. Figure 4 of EN 1337-2:2004 shows the configurations of curved MSM[®] sheets for cylindrical sliding surfaces.

B.1.4 MSM[®] sheets for MAURER Multisurface Spherical Bearings

As an alternative to the geometrical rules given above flat and curved surfaces of spherical bearings made of MSM[®] may consist of one centric circular sheet with diameter "a" and one or more concentric annuli with a constant width "b". The dimensions "a" and "b" shall not be smaller than 50 mm. The radial distance "f" between the individual sheets shall not be less than 10 mm and not greater than twice the thickness of the backing plate of the special sliding material or the mating material, whichever is least. The annuli may be subdivided into segments. Both the disc and the annulus may be retained in recesses. Figure B.4 shows the configurations of flat and curved MSM[®] sheets for MAURER MSM[®] Multisurface Spherical Bearings.

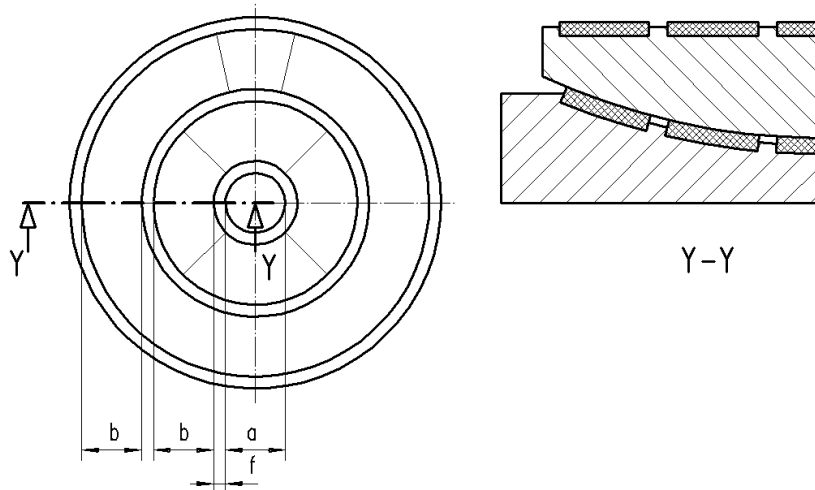

Figure B.4 - Subdivision of recessed MSM[®] sheets for MAURER MSM[®] Multisurface Spherical Bearings (Example)

B.1.5 MSM[®] sheets for guides

Dimension "a" shall not be less than 15 mm and the modified shape factor

$$S = \frac{A_{\text{MSM}}}{u \cdot h} \cdot \frac{t_{\text{MSM}} - h}{h}$$

shall be greater than 4 (see figure B.5). A_{MSM} is the compressed (undeformed) surface and u the perimeter of the MSM[®] sheet.

Dimensions in millimeters

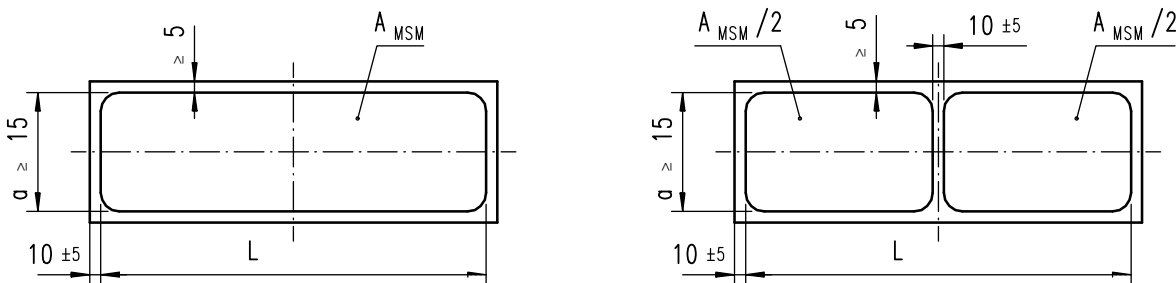
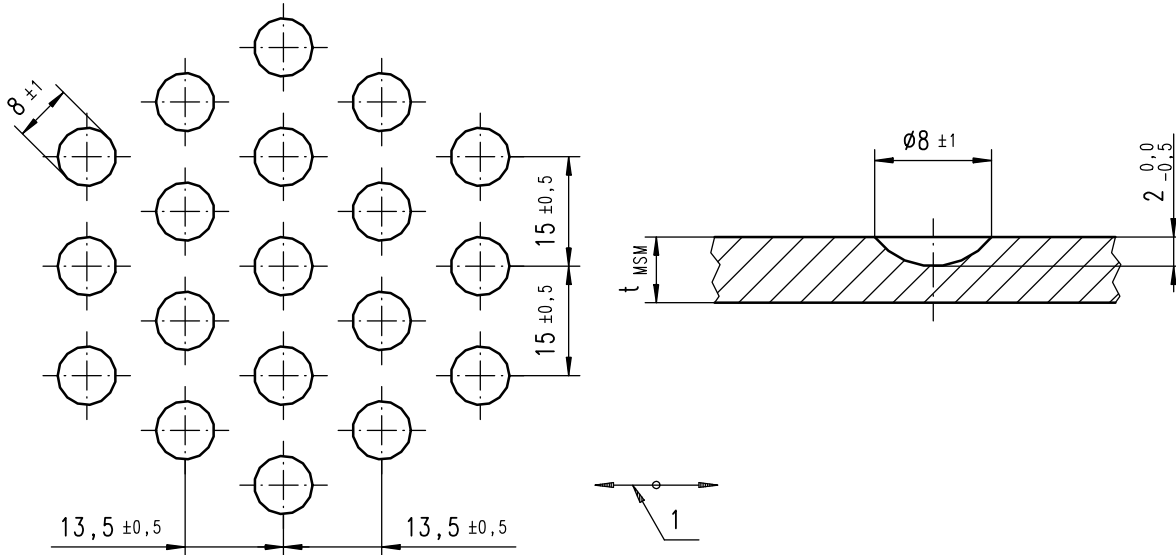

Figure B.5 - Examples of recessed MSM[®] sheets for guides

B.2 Dimple pattern for sliding elements with MSM[®]

For pressures due to characteristic permanent actions G_k exceeding 5 MPa uniform pattern of dimples shall be provided to retain the lubricant. The shape and arrangement of the dimples in the unloaded and unused condition and the alignment with the main direction of sliding is shown in figure B.6.

Dimensions in millimeters



Key

1 main direction of sliding

Figure B.6 - Pattern of dimples in recessed MSM[®] sheets

ANNEX C

Reduced area for circular sliding elements

The values of the coefficient λ have been calculated by means of a mathematical model made with the following assumptions:

- 1) only compressive stresses are transmitted
- 2) the stresses in the compressed area are constant and equal to the design value f_d of compressive resistance of MSM[®] sheets (i.e. the stress block theory is adopted)
- 3) stresses are always normal to the contact surface: a conservative hypothesis justified by the low coefficient of friction of MSM[®] in contact with polished metal surfaces
- 4) the adjacent backing plates are perfectly rigid

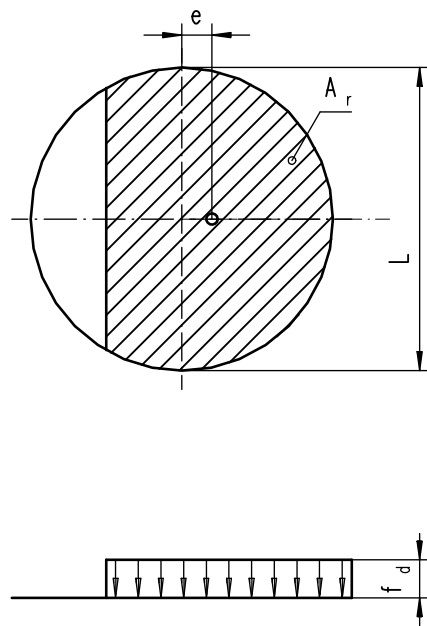

Figure C.1 - Reduced contact area A_r for circular sliding surfaces.

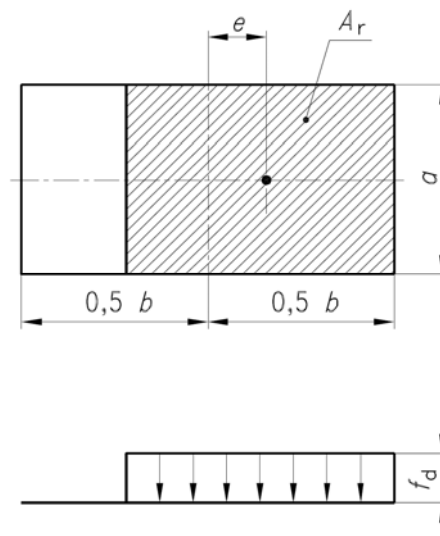

Figure C.2 - Reduced contact area A_r for rectangular sliding surfaces

$$A_r = \lambda \cdot A$$

English translation prepared by DIBt

where is

λ Coefficient given in Table C.1.

A Contact area for flat sliding surfaces or projection area of the curved sliding surface

$$A = \pi L^2 / 4$$

As an alternative to the exact values given in Table C.1, the following approximate formula can be used for flat sliding surfaces of spherical bearings:

$$\lambda = 1 - 0.75 \pi e / L$$

Table C.1 - Coefficient $\lambda = A_r / A$

| e / L | sliding surface | | | | | | | | |
|--------|-----------------|-------------|-------|-------|-------|-------------|-------|-------|-------|
| | flat | spherical | | | | cylindrical | | | |
| | | ϑ | | | | | | | |
| | | 30° | 25° | 20° | 10° | 30° | 25° | 20° | 10° |
| 0.00 | | | | | | | | | |
| 0.05 | 0.990 | 0.991 | 0.991 | 0.990 | 0.990 | | | | |
| 0.01 | 0.979 | 0.982 | 0.981 | 0.980 | 0.979 | 0.984 | 0.983 | 0.981 | 0.980 |
| 0.02 | 0.957 | 0.962 | 0.961 | 0.960 | 0.958 | 0.968 | 0.965 | 0.962 | 0.961 |
| 0.03 | 0.934 | 0.942 | 0.940 | 0.938 | 0.936 | 0.951 | 0.947 | 0.943 | 0.941 |
| 0.04 | 0.912 | 0.922 | 0.919 | 0.916 | 0.913 | 0.934 | 0.929 | 0.924 | 0.921 |
| 0.05 | 0.888 | 0.901 | 0.898 | 0.894 | 0.890 | 0.917 | 0.911 | 0.905 | 0.901 |
| 0.06 | 0.865 | 0.880 | 0.876 | 0.872 | 0.867 | 0.900 | 0.893 | 0.886 | 0.881 |
| 0.07 | 0.841 | 0.858 | 0.853 | 0.849 | 0.844 | 0.882 | 0.874 | 0.866 | 0.862 |
| 0.08 | 0.818 | 0.836 | 0.831 | 0.826 | 0.820 | 0.864 | 0.855 | 0.847 | 0.842 |
| 0.09 | 0.793 | 0.814 | 0.808 | 0.803 | 0.796 | 0.846 | 0.837 | 0.827 | 0.822 |
| 0.10 | 0.769 | 0.792 | 0.786 | 0.780 | 0.773 | 0.828 | 0.818 | 0.808 | 0.802 |
| 0.11 | 0.745 | 0.770 | 0.763 | 0.757 | 0.749 | 0.809 | 0.799 | 0.788 | 0.782 |
| 0.12 | 0.722 | 0.747 | 0.740 | 0.733 | 0.724 | 0.790 | 0.779 | 0.768 | 0.762 |
| 0.1255 | 0.709 | 0.736 | 0.729 | 0.722 | 0.712 | 0.780 | 0.769 | 0.758 | 0.752 |
| 0.13 | 0.697 | 0.725 | 0.717 | 0.710 | 0.700 | 0.771 | 0.760 | 0.749 | 0.742 |
| 0.14 | 0.673 | 0.702 | 0.693 | 0.686 | 0.676 | 0.752 | 0.740 | 0.729 | 0.722 |
| 0.15 | 0.649 | 0.680 | 0.670 | 0.663 | 0.653 | 0.733 | 0.721 | 0.709 | 0.702 |
| 0.16 | 0.625 | 0.657 | 0.647 | 0.639 | 0.628 | 0.713 | 0.701 | 0.689 | 0.682 |
| 0.17 | 0.601 | 0.635 | 0.624 | 0.616 | 0.604 | 0.693 | 0.681 | 0.669 | 0.662 |
| 0.18 | 0.577 | 0.612 | 0.601 | 0.592 | 0.581 | 0.673 | 0.661 | 0.649 | 0.642 |
| 0.19 | 0.552 | 0.590 | 0.578 | 0.569 | 0.557 | 0.653 | 0.641 | 0.629 | 0.622 |
| 0.20 | 0.529 | 0.567 | 0.556 | 0.546 | 0.533 | 0.633 | 0.621 | 0.609 | 0.602 |
| 0.21 | 0.506 | 0.545 | 0.533 | 0.523 | 0.510 | 0.612 | 0.600 | 0.589 | 0.582 |
| 0.2155 | 0.500 | 0.541 | 0.529 | 0.518 | | 0.602 | 0.590 | 0.579 | 0.572 |
| 0.22 | 0.482 | 0.523 | 0.511 | 0.500 | | 0.592 | 0.580 | 0.569 | 0.562 |
| 0.23 | 0.458 | 0.501 | | | | 0.571 | 0.559 | 0.548 | 0.542 |
| 0.24 | 0.435 | | | | | 0.550 | 0.539 | 0.528 | 0.522 |
| 0.25 | 0.412 | | | | | 0.529 | 0.518 | 0.508 | 0.502 |

NOTE Intermediate values may be obtained by linear interpolation

Electronic copy of the ETA by DIBt: ETA-06/0131

ANNEX D

Method for calculation the eccentricities in MAURER MSM[®] spherical and cylindrical bearings

D.1 General

Frictional forces, forces from applied horizontal loads and the rotated condition of the bearing produce eccentricity of the axial force N_s , which is used in the verification of MSM[®] sheets, the adjacent structural members and the anchoring devices. This annex gives methods for calculating the significant eccentricities. Depending on the design features of a particular bearing, additional eccentricities may exist. When several eccentricities occur in a cross-section under consideration, they need to be added.

D.2 Friction resistance

D.2.1 Curved sliding surfaces

In the presence of rotational movements an internal moment occurs due to the frictional resistance. Regardless of whether the bearing has one or two surfaces, the associated eccentricity e_1 is:

$$e_1 = \mu_{\max} \cdot r$$

The coefficient of friction μ_{\max} is given in 2.2.7.

D.2.2 Sliding surfaces with external guides and restraining rings

For the spherical and cylindrical bearings of the type shown in figures A.3 c) and d) of Annex A rotational movements produce an eccentricity which affects only the adjacent structural members (i.e. plinth, beam etc) and the anchoring devices, where:

$$e_2 = \frac{V_s}{N_s} \cdot \mu_{\max} \cdot c$$

For bearings with sliding elements in guides as per Table 1, the coefficient of friction μ_{\max} is given in 2.2.7. For restraining rings with steel to steel contact μ_{\max} should be assumed to be 0.2.

D.3 Rotation

In all the types of bearings with two sliding surfaces a rotation angle α produces an eccentricity e_3 of the vertical load on the curved surface equal to:

$$e_3 = \alpha \cdot (r + b)$$

where b represents the distance between the cross-section under consideration and the sliding surface. At any rate, this eccentricity acts nonetheless in the opposite direction to that given under 4.2. The occurrence of e_3 depends on whether the curved MSM[®] sheet is either attached to the convex or concave backing plate and whether the value α is greater or lesser than μ as well as the bearing clearance is performing its function effectively in the case of guided bearings. In the type of bearings equipped with only one sliding surface e_3 occurs only in the curved MSM[®] sheet and, furthermore, only when said sheet is attached to the convex backing plate.

D.4 Lateral forces

Lateral forces result from horizontal actions and the friction resistance of the other bearings in the structure. In bearings where lateral forces are transmitted by external guides or restraining rings, the eccentricity in the curved sliding surface is equal to zero. In bearings of the fixed type with only one sliding surface or with internal guides the horizontal load V_s produces an eccentricity given by:

$$e_4 = \frac{V_s}{N_s} \cdot (r + b)$$

In all cases where the lines of application of lateral action and reaction are not coincident the resulting couple causes an eccentricity that shall be additionally taken into account.

ANNEX E

Backing plates

E.1 General

Dimensional limitations of backing plates with concave surfaces are shown in figure E.1.

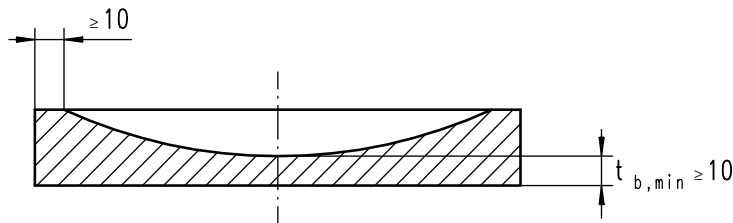

Figure E.1 – Dimensional limitations of a backing plate with a concave surface

E.2 MSM[®] confinement

The shoulders of the recess shall be sharp edged and square to restrict the flow of MSM[®] (see Annex B, figure B.1). The radius at the root of the recess shall not exceed 1 mm. The depth of the confining recess shall be related to the dimensions of the MSM[®] sheet in accordance with Annex B. In principle the MSM[®] sheet shall fit the recess without clearance. Intermittent gaps between the edge of the MSM[®] sheet and the recess shall not exceed the values given in Table E.1 at room temperature.

Table E.1 - Fit of confined MSM[®] sheets.

| Dimension L [mm] | Gap [mm] |
|----------------------|----------|
| $75 \leq L \leq 600$ | 0.6 |
| $600 < L \leq 1200$ | 0.9 |
| $1200 < L \leq 1500$ | 1.2 |

For diameters L between 1500 and 2500 mm the gaps are limited to $L[\text{mm}]/1250$.

where is

L Diameter according to Annex B

E.3 Flatness

Surfaces of backing plates in contact with sliding materials or anchor and shimming plates shall be treated in such a way that the maximum deviation Δz from theoretical plane surface shall not exceed $0.0003 \cdot d$ or 0.2 mm, whichever is greater.

E.4 Fit of sliding surfaces

The maximum deviation Δz from theoretical plane or curved surface within the area of the mating MSM[®] sheet shall not exceed $0.0003 \cdot L$ or 0.2 mm, whichever is greater.

E.5 Method for calculating the deformation of backing plates attached to concrete

For circular steel plates attached to concrete structural members of concrete strength class C20/25 according to ENV 1992-1-1:2004 or greater and mortar layers of equivalent strength, the maximum relative deformation Δw over the diameter L is given by the equation below:

$$\Delta w = \frac{0.55}{L} \cdot k_c \cdot \alpha_c \cdot k_b \cdot \alpha_b$$

with

$$k_c = 1.1 + (1.7 - 0.85 \cdot d_b / L) \cdot (2 - d_b / L_0) \quad \text{if } L_0 \leq d_b \leq 2 \cdot L_0$$

$$k_c = 1.1 \quad \text{if } d_b > 2 \cdot L_0$$

$$\alpha_c = \frac{N_{Qd}}{E_{cd}} + \frac{N_{Gd}}{E_{crd}}$$

$$k_b = 0.30 + 0.55 \cdot d_b / L$$

$$\alpha_b = \left(\frac{L}{L + 2 \cdot t_b} \right)^2 \cdot \left(\frac{3 \cdot L_0}{d_b} \right)^{0.4}$$

where is

d_b diameter of the backing plate

t_b thickness of the backing plate; for backing plates with a concave surface the calculation may be based on the equivalent constant thickness

$$t'_b = t_{b,\min} + 0.6 (t_{b,\max} - t_{b,\min})$$

L diameter of MSM[®] sheet

L_0 reference diameter = 300 mm

N_{Qd} design axial force due to variable actions

N_{Gd} design axial force due to permanent actions

E_{cd} design secant modulus of elasticity of concrete

E_{crd} design reduced modulus of elasticity of concrete, for the determination of creep when acted upon by permanent design actions N_{Gd} ($E_{crd} \cong 1/3 E_{cd}$)

The above approximate procedure may also be applied to square plates and rectangular plates if they are idealised to circular plates of diameter

$$d_b = 1.13 a_b$$

where a_b is the side of the square plate or the minor side of the rectangular plate.