

## European Technical Approval ETA-06/0247

English translation prepared by DIBt - Original version in German language

Handelsbezeichnung <i>Trade name</i>	KEIL Hinterschnittanker KH für mineralit® - Fassadenplatten <i>KEIL undercur anchor KH for mineralit® - façade panels</i>
Zulassungsinhaber <i>Holder of approval</i>	Mineralit GmbH Laage Heinrich Lanz-Straße 4 18299 Laage/Kronskamp DEUTSCHLAND
Zulassungsgegenstand und Verwendungszweck <i>Generic type and use of construction product</i>	Spezialdübel zur rückseitigen Befestigung von Fassadenplatten aus Mineralguss (Polymerbeton) <i>Special anchor for the rear fixing of façade panels made of mineral cast (polymer concrete)</i>
Geltungsdauer: <i>Validity:</i>	vom <i>from</i> bis <i>to</i> 27 June 2013 27 June 2018
Herstellwerke <i>Manufacturing plants</i>	KEIL Hinterschnittanker KH: Keil Befestigungstechnik GmbH mineralit® - Fassadenplatte: mineralit® GmbH

Diese Zulassung umfasst  
*This Approval contains*

19 Seiten einschließlich 10 Anhänge  
*19 pages including 10 annexes*

## I LEGAL BASES AND GENERAL CONDITIONS

- 1 This European technical approval is issued by Deutsches Institut für Bautechnik in accordance with:
  - Council Directive 89/106/EEC of 21 December 1988 on the approximation of laws, regulations and administrative provisions of Member States relating to construction products<sup>1</sup>, modified by Council Directive 93/68/EEC<sup>2</sup> and Regulation (EC) N° 1882/2003 of the European Parliament and of the Council<sup>3</sup>;
  - *Gesetz über das In-Verkehr-Bringen von und den freien Warenverkehr mit Bauprodukten zur Umsetzung der Richtlinie 89/106/EWG des Rates vom 21. Dezember 1988 zur Angleichung der Rechts- und Verwaltungsvorschriften der Mitgliedstaaten über Bauprodukte und anderer Rechtsakte der Europäischen Gemeinschaften (Bauproduktengesetz - BauPG) vom 28. April 1998<sup>4</sup>, as amended by Article 2 of the law of 8 November 2011<sup>5</sup>;*
  - Common Procedural Rules for Requesting, Preparing and the Granting of European technical approvals set out in the Annex to Commission Decision 94/23/EC<sup>6</sup>.
- 2 Deutsches Institut für Bautechnik is authorized to check whether the provisions of this European technical approval are met. Checking may take place in the manufacturing plant. Nevertheless, the responsibility for the conformity of the products to the European technical approval and for their fitness for the intended use remains with the holder of the European technical approval.
- 3 This European technical approval is not to be transferred to manufacturers or agents of manufacturers other than those indicated on page 1, or manufacturing plants other than those indicated on page 1 of this European technical approval.
- 4 This European technical approval may be withdrawn by Deutsches Institut für Bautechnik, in particular pursuant to information by the Commission according to Article 5(1) of Council Directive 89/106/EEC.
- 5 Reproduction of this European technical approval including transmission by electronic means shall be in full. However, partial reproduction can be made with the written consent of Deutsches Institut für Bautechnik. In this case partial reproduction has to be designated as such. Texts and drawings of advertising brochures shall not contradict or misuse the European technical approval.
- 6 The European technical approval is issued by the approval body in its official language. This version corresponds fully to the version circulated within EOTA. Translations into other languages have to be designated as such.

<sup>1</sup> Official Journal of the European Communities L 40, 11 February 1989, p. 12  
<sup>2</sup> Official Journal of the European Communities L 220, 30 August 1993, p. 1  
<sup>3</sup> Official Journal of the European Union L 284, 31 October 2003, p. 25  
<sup>4</sup> *Bundesgesetzblatt Teil I 1998*, p. 812  
<sup>5</sup> *Bundesgesetzblatt Teil I 2011*, p. 2178  
<sup>6</sup> Official Journal of the European Communities L 17, 20 January 1994, p. 34

## II SPECIFIC CONDITIONS OF THE EUROPEAN TECHNICAL APPROVAL

### 1 Definition of the product and intended use

#### 1.1 Definition of the product

The system "KEIL undercut anchor KH for mineralit® - façade panels" consist of a special anchor made of stainless steel and a façade panel made of polymer concrete. The anchor consists of a crosswise slotted anchor sleeve with an M6 internal thread, at the upper edge of which a hexagon is formed to it and a respective hexagon bolt with an integrated tooth lock washer. The anchor is put into an undercut drill hole and by driving-in the screw it is placed form-fitted and deformation-controlled.

For the installed anchor see figure in Annex 1.

#### 1.2 Intended use

The "KEIL undercut anchor KH" may be used for the rear fixing of façade panels made of polymer concrete. The façade panels shall correspond to the drawings and specifications of the annexes.

The façade panels with rear fixing by the anchor may only be used for front curtain walls. Each façade panel shall be fixed technically strain-free with at least four anchors in a rectangular arrangement via single agraffes or double agraffes on a capable substructure.

The anchor may be used in structures subject to dry internal conditions and also in structures subject to external atmospheric exposure (including industrial and marine environment), if no particular aggressive conditions exist. Such particular aggressive conditions are e.g. permanent, alternating immersion in seawater or the splash zone of seawater, chloride atmosphere of indoor swimming pools or atmosphere with extreme chemical pollution (e.g. in desulphurisation plants or road tunnels where de-icing materials are used).

The provisions made in this European technical approval are based on an assumed working life of the anchor and the façade panels of 50 years. The indications given on the working life cannot be interpreted as a guarantee given by the producer, but are to be regarded only as a means for choosing the right products in relation to the expected economically reasonable working life of the works.

### 2 Characteristics of the product and method of verification

#### 2.1 Characteristics of the product

The anchor and the façade panels correspond to the drawings and specifications given in Annex 2 and Annex 5. The characteristic material values, dimensions and tolerances of the anchor and façade panels not indicated in Annexes shall correspond to the respective values laid down in the technical documentation<sup>7</sup> of this European technical approval.

<sup>7</sup> The technical documentation comprises all information necessary for the production, installation and maintenance of the anchor; these are in particular the design drawings and the installation instructions. The part to be treated confidentially is deposited with Deutsches Institut für Bautechnik and, as far as this is relevant to the tasks of the approved bodies involved in the procedure of attestation of conformity, shall only be handed over to the approved body.

The anchor is considered to satisfy the requirements for performance class A1 of the characteristic reaction to fire, in accordance with the provisions of EC decision 96/603/EC (as amended by 2000/605/EG) without the need for testing on the basis of its listing in that decision.

In addition to the specific clauses relating to dangerous substances contained in this European technical approval, there may be other requirements applicable to the products falling within its scope (e.g. transposed European legislation and national laws, regulations and administrative provisions). In order to meet the provisions of the Construction Products Directive, these requirements need also to be complied with, when and where they apply.

The characteristic values for the design of the façade panels with rear fixing by the anchor are given in Annex 5.

Every anchor is marked with the identifying mark of the producer and the anchor size according to Annex 2.

The Anchor shall only be packaged and supplied as a complete unit (anchor sleeve and screw).

## 2.2 Methods of verification

The assessment of fitness of the anchor and the façade panel for the intended use in relation to the requirements for safety in use in the sense of the Essential Requirement 4 of Council Directive 89/106/EEC has been made based on the following tests:

- (1) Axial tension tests
- (2) Shear tests
- (3) Tests with combined tension and shear loading
- (4) Tests on structural members
- (5) Tests on functioning under repeated loads
- (6) Tests on functioning under sustained loads
- (7) Tests on functioning under freeze/thaw conditions (25 freeze/thaw cycles)
- (8) Tests on functioning after immersion in water.

## 3 Evaluation and attestation of conformity and CE marking

### 3.1 System of attestation of conformity

According to the communication of the European Commission<sup>8</sup> the system 2 (ii)-1 (referred to as System 2+) of attestation of conformity applies.

These systems of attestation of conformity are defined as follows:

System 2+: Declaration of conformity of the product by the manufacturer on the basis of:

- (a) Tasks for the manufacturer:
  - (1) initial type-testing of the product;
  - (2) factory production control;
  - (3) testing of samples taken at the factory in accordance with a prescribed test plan.
- (b) Tasks for the approved body:
  - (4) certification of factory production control on the basis of:
    - initial inspection of factory and of factory production control;
    - continuous surveillance, assessment and approval of factory production control.

<sup>8</sup>

Letter of the European Commission of 22/07/2002 to EOTA

### 3.2 Responsibilities

#### 3.2.1 Tasks for the manufacturer

##### 3.2.1.1 Factory production control

The manufacturer shall exercise permanent internal control of production. All the elements, requirements and provisions adopted by the manufacturer shall be documented in a systematic manner in the form of written policies and procedures, including records of results performed. This production control system shall insure that the product is in conformity with this European technical approval.

The manufacturer may only use initial materials and components stated in the technical documentation of this European technical approval.

The factory production control shall be in accordance with the control plan<sup>9</sup> which is part of the technical documentation of this European technical approval. The control plan is laid down in the context of the factory production control system operated by the manufacturer and deposited with Deutsches Institut für Bautechnik.

The results of factory production control shall be recorded and evaluated in accordance with the provisions of the control plan.

##### 3.2.1.2 Other tasks for the manufacturer

The manufacturer shall, on the basis of a contract, involve a body which is approved for the tasks referred to in section 3.1 in the field of "anchors and façade panels" in order to undertake the actions laid down in section 3.2.2. For this purpose, the control plan referred to in sections 3.2.1.1 and 3.2.2 shall be handed over by the manufacturer to the approved body involved.

The manufacturer shall make a declaration of conformity, stating that the construction product is in conformity with the provisions of this European technical approval.

#### 3.2.2 Tasks of approved bodies

The approved body shall perform the following tasks in accordance with the provisions laid down in the control plan:

- initial inspection of factory and of factory production control,
- continuous surveillance, assessment and approval of factory production control.

The approved body shall retain the essential points of its actions referred to above and state the results obtained and conclusions drawn in a written report.

The approved certification body involved by the manufacturer shall issue an EC certificate of conformity of the factory production control stating the conformity with the provisions of this European technical approval.

In cases where the provisions of the European technical approval and its "control plan" are no longer fulfilled the certification body shall withdraw the certificate of conformity and inform Deutsches Institut für Bautechnik without delay.

<sup>9</sup> The control plan is a confidential part of the European technical approval and only handed over to the approved body involved in the procedure of attestation of conformity. See section 3.2.2.

### 3.3 CE marking

The CE marking shall be affixed on the packaging or accompanying commercial document, e.g. the EC declaration of conformity. The letters „CE“ shall be followed by the identification number of the approved certification body, where relevant, and be accompanied by the following additional information:

- the name and address of the producer (legal entity responsible for the manufacturer),
- the last two digits of the year in which the CE marking was affixed,
- the number of the EC certificate for the factory production control,
- the number of the European technical approval,
- use category (25 freeze/thaw cycles),
- size.

## 4 Assumptions under which the fitness of the product for the intended use was favourably assessed

### 4.1 Manufacture

The product is manufactured in accordance with the provisions of the European technical approval using the automated manufacturing process as identified in the inspection of the plant by Deutsches Institut für Bautechnik and the approved body and laid down in the technical documentation.

The European technical approval is issued for the product on the basis of agreed data/information, deposited with Deutsches Institut für Bautechnik, which identifies the product that has been assessed and judged. Changes to the product or production process, which could result in this deposited data/information being incorrect, should be notified to Deutsches Institut für Bautechnik before the changes are introduced. Deutsches Institut für Bautechnik will decide whether or not such changes affect the European technical approval and consequently the validity of the CE marking on the basis of the European technical approval and if so whether further assessment or alterations to the European technical approval shall be necessary.

### 4.2 Installation

#### 4.2.1 Design

The fitness for the intended use is given under the following conditions:

- The mineralit® façade panels made of polymer concrete correspond to the drawings and specifications of the annexes. The characteristic material values, dimensions and tolerances of the façade panels not indicated in the annexes shall correspond to the respective values laid down in the technical documentation<sup>10</sup> of this European technical approval.
- Each façade panel is fixed with at least four anchors in rectangular arrangement via single agraffes or double agraffes to the substructure; the substructure is constructed such that the façade panels are fixed technically strain-free via skids (loose bearings) and one fixed bearing (see Annex 5 to 10).
- Two fixing points of the façade panel are designed such that they are able to carry the dead load of the façade panel.
- The load-bearing profiles are arranged symmetrically. The arrangement of the agraffes ensures a symmetric introduction of the load into the substructure.

<sup>10</sup> The technical documentation comprises all information necessary for the production, installation and maintenance of the anchor; these are in particular the design drawings and the installation instructions. The part to be treated confidentially is deposited with Deutsches Institut für Bautechnik and, as far as this is relevant to the tasks of the approved bodies involved in the procedure of attestation of conformity, shall only be handed over to the approved body.

- When using agraffes on horizontal load-bearing profiles the fixing points of a façade panel situated horizontally at the same height are fastened in each case to the same load-bearing profile.
- The façade panels neither are used to transmit impact loads nor for guard rail.
- Joint construction between the façade panels is done by a joint filler or are kept open. It is ensured that additional stresses (e.g. by temperature) do not lead to important additional loadings.
- Taking account of the loads to be fixed checkable calculations and construction drawings are prepared; the position of the anchor is given in the construction drawing.
- The façade panels, their fixings as well as the substructure including its connection to wall brackets and their connection to the construction works are designed under the responsibility of an engineer skilled in the field of façade construction taking account the load effects (dead load, wind load) for the respective case of application and the following conditions:

- The design values of the actions shall be calculated on basis of EN 1990 in consideration of the existing loads. The combinations of actions shall be equal to EN 1990. The actions shall be specified according to EN 1991-1-1 to EN 1991-1-7. Corresponding national regulations shall be taken into consideration. The unfavourable combination is decisive. Where necessary for the design of the anchor and the façade panel several combinations shall be analysed separately. The typical fundamental combination for façade panels considers actions from dead load  $F_{Sk,G}$  (permanent action) and wind  $F_{Sk,w}$  (leading variable action)
- For the bearing types and panel sizes according to Annex 6 to 10 the verification of structural stability is deemed to be verified, if the following conditions are met:

$$w_{Ed} \leq w_{Rk} / \gamma_M$$

with  $w_{Ed}$  [kN/m<sup>2</sup>] = design value of the existing wind load

$w_{Rk}$  [kN/m<sup>2</sup>] = characteristic resistance to wind load according to Annex 6 to 10

$\gamma_M$  [-] = partial safety factor according to Annex 6 to 10

- For formats, which relevant differ from the bearing types and panel sizes according to Annex 6 to 10, the verification of structural stability of the façade panels including its fixing by the anchor is carried out separately. For the determined forces conditions is to be verified, that the following equation is observed:

$$F_d \leq R_k / \gamma_M$$

with  $F_d$  [kN] = design value of the relevant existing force ( $N_{Ed}$ ,  $V_{Ed}$ ,  $\sigma_{Ed}$ )

$R_k$  [kN] = characteristic resistance to the relevant force ( $N_{Rk}$ ,  $V_{Rk}$ ,  $\sigma_{Rk}$ ) according to Annex 5

$\gamma_M$  [-] = partial safety factor according to Annex 5

In case of coincident stress of an anchor due to tension and shear load the equation according to Annex 5 is observed

- For flush fixed anchors and for installation of horizontal load-bearing profiles permanent loads due to torsion of the profile shall be considered in addition to actions from dead loads and wind in direction of the anchor axes. Simplifying these permanent loads can be determined as follows:

Load due to torsion of the load-bearing profile resulting from dead load of the façade panel

$$N_{V,Ek} = V_{Ek} \cdot 2e/c_H$$

with  $V_{Ek}$  = shear load due to dead load of the façade panel

$e$  und  $c_H$  [mm] see Annex 4

The load due to torsion can be neglected, when there is no horizontal distance between anchor and vertical load-bearing profile.

- For stand-off fixed anchors and for installation of horizontal load-bearing profiles the following shall be verified:
  - The agraffes do not prop on the façade panel due to torsion of the horizontal load-bearing profile and twisting of the façade panel.
  - The total of the angle  $\alpha$  results from torsion of the horizontal load-bearing profile and twisting of the façade panel at the fixing point does not exceed the value  $\alpha = 2^\circ$ .
- For the design relevant characteristic values of the anchor (resistance, edge distances and spacing) and of the panel (bending strength, modulus of elastic, Poisson's ratio,  $\alpha_T$ , dead load) shall be taken from Annex 5.

#### 4.2.2 Installation

The fitness for use can be assumed only, if the following installation conditions are observed:

- Installation by appropriately qualified personnel under the supervision of the project supervisor
- Installation only as delivered by the manufacturer without exchanging the individual parts.
- Installation according to manufacturer's specifications and construction drawings using the tools indicated in the installation instructions.
- Making of the undercut drillings on the back side of the façade panels at the factory or with the transportable drilling equipment of the company KEIL under workshop conditions on site using the KEIL façade drill according to Annex 3 and a special drilling equipment corresponding to the information deposited with Deutsches Institut für Bautechnik. The execution is supervised by the responsible project supervisor or a skilled representative of the project supervisor.
- The drillings are removed from the drill hole; the nominal diameter of the drill corresponds to the values of Annex 3; in case of aborted drill hole a new drilling at a minimum spacing of at least twice the depth of the aborted drill hole is arranged.
- The geometry of the drill hole is checked on 1 % of all drillings. The following dimensions shall be checked and documented according to manufacturer's information and testing instructions by means of a measuring device according to Annex 3.
  - volume of the undercut drill hole
  - depth position of the undercut. The distance between the lower edge of the measuring device and the façade panel is between 0 and 0.3 mm (see Annex 3).

If the tolerances given are exceeded, the geometry of the drill hole shall be checked on 25% of the drillings performed. No further drill hole may exceed the tolerances otherwise all the drill holes shall be controlled. Drilling holes falling below or exceeding the tolerances shall be rejected.

- Between agraffe and façade panel an elastic sandwich layer may placed.
- Fixing the screw with a torque moment  $2.5 \text{ Nm} \leq T_{\text{inst}} \leq 4.0 \text{ Nm}$  using a calibrated torque wrench.
- During transport and storage on site the façade panels are protected from damages; the façade panels are not be hung up jerkily (if need be lifters shall be used for hanging up the façade panels); façade panels and reveal panels respectively with incipient cracks are not be installed.



## 5 Indications to the manufacturer

It is in the responsibility of the manufacturer to ensure that the information on the specific conditions according to 1 and 2 including Annexes referred to and 4.2.1 and 4.2.2 is given to those who are concerned. This information may be made by reproduction of the respective parts of the European technical approval. In addition all installation data shall be shown clearly on the package and/or on an enclosed instruction sheet, preferably using illustration(s).

The minimum data required are:

- setting depth,
- thickness of the joint structure.

All data shall be presented in a clear and explicit form.

Andreas Kummerow  
p. p. Head of Department

beglaubigt:  
Bürger

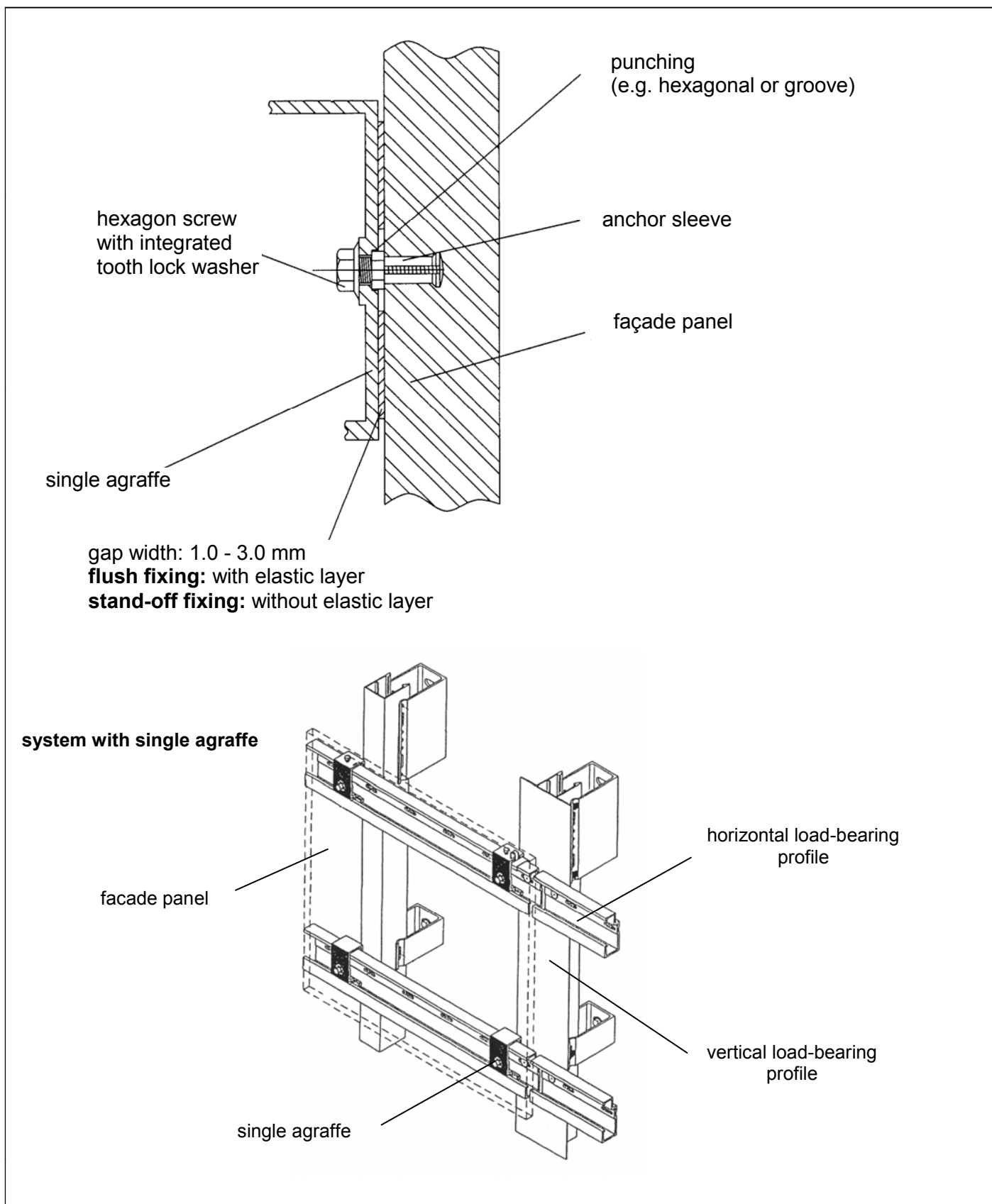

KEIL undercur anchor KH for mineralit® - façade panels

Product and intended use

Annex 1

**Anchor parts**

**Anchor sleeve**

stainless steel 1.4404 EN 10088

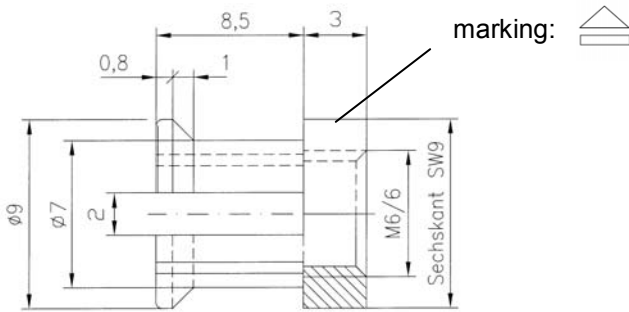

**Hexagon screw with integrated tooth lock washer**

stainless steel 1.4401, 1.4404 or 1.4578 EN 10088

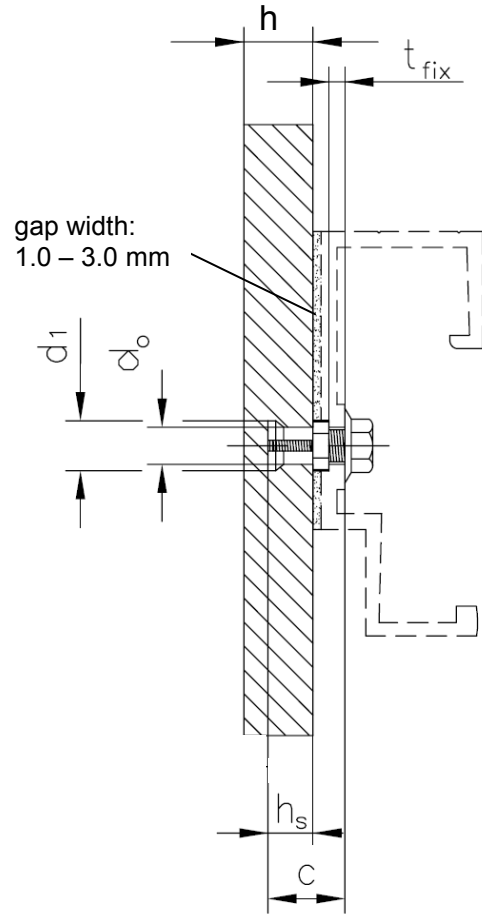
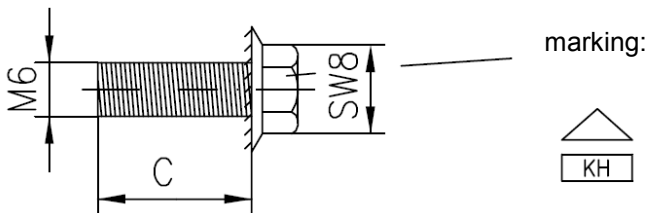

**Table 1: Characteristic values of anchor installation**

anchor type		KH AA 8.5
panel thickness	$h =$ [mm]	12.0
setting depth	$h_s =$ [mm]	8.5
diameter of drill hole	$d_o =$ [mm]	7.0
diameter of undercut	$d_1 =$ [mm]	9.0
thickness of the agraffe	$t_{fix} =$ [mm]	$\geq 1.5$
threaded length of screw	$c =$ [mm]	$11.5 + t_{fix}$
installation torque moment	$T_{inst}$ [Nm]	$2.5 \leq T_{inst} \leq 4.0$

KEIL undercut anchor KH for mineralit® - façade panels

Anchor parts  
Characteristic values for anchor installation

Annex 2

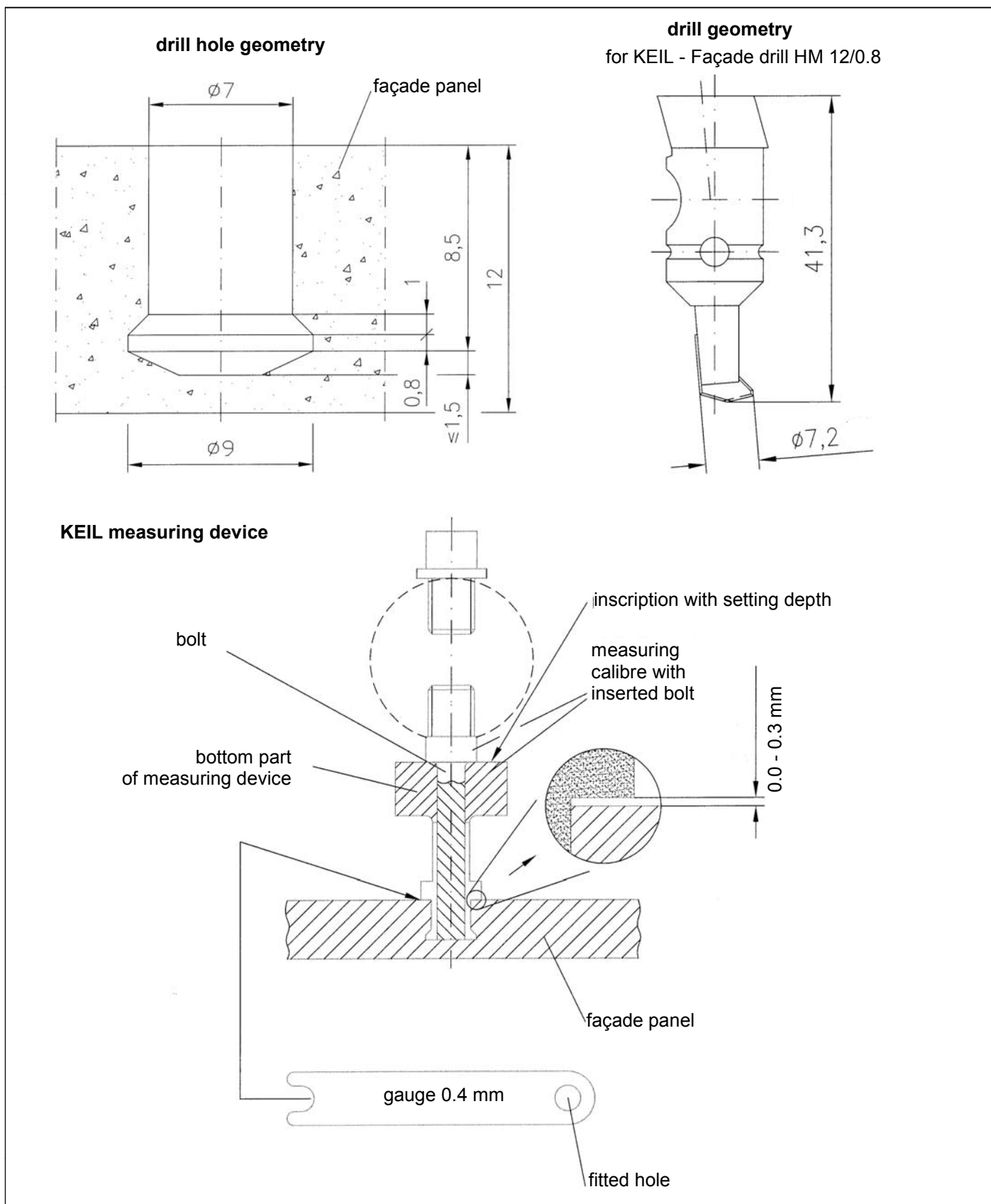

KEIL undercur anchor KH for mineralit® - façade panels

Drill- and drill hole geometry  
Measuring device

Annex 3

### Torsion of horizontal load-bearing profiles resulting from dead load of the façade panels

For flush fixed anchors and for installation of horizontal load-bearing profiles permanent loads due to torsion of the profile shall be considered in addition to actions from dead loads and wind in direction of the anchor axes. Simplifying these permanent loads can be determined as follows:

$$N_{V,Ek} = V_{Ek} \cdot 2e/c_H$$

$V_{Ek}$  = shear load due to dead load of the façade panel

$e$  und  $c_H$  [mm] see picture

$M$  shear centre

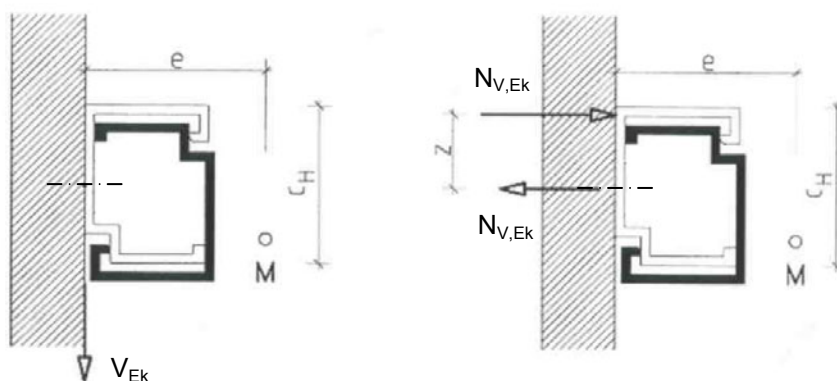

**Table 2: Characteristic values of the anchor and façade panel**

characteristic values of the mineralit® façade panel	max. proportion of panel	$L_x/L_y$ or $L_y/L_x$	[-]	1/3	
	panel thickness	$h_{nom} =$	[mm]	12	
	resistance to bending stress	$\sigma_{Rk} =$	[N/mm <sup>2</sup> ]	24.5	
	partial safety factor <sup>1)</sup>	$\gamma_M =$	[-]	2.0	
	E-Modul	$E =$	[N/mm <sup>2</sup> ]	20000	
	dead load	$g =$	[kN/m <sup>2</sup> ]	0.34	
characteristic values of the anchor KEIL - undercut anchor KH	resistance to <sup>2)</sup>	tension load	$N_{Rk} =$	[kN]	1.9
		shear load	$V_{Rk} =$	[kN]	5.2
	partial safety factor <sup>1)</sup>	$\gamma_M =$	[-]	2.0	
	setting depth	$h_s \geq$	[mm]	8.5	
	edge distance	$a_{rx}$ or $a_{ry} \geq$	[mm]	75	
	spacing	$a \leq$	[mm]	800	

<sup>1)</sup> in absence of other national regulations

<sup>2)</sup> in case of coincident stress of an anchor due to tension and shear load the following equation shall be observed:  $\frac{N_{Ed}}{N_{Rd}} + \frac{V_{Ed}}{V_{Rd}} \leq 0.9$

**Definition of edge distance and spacing**

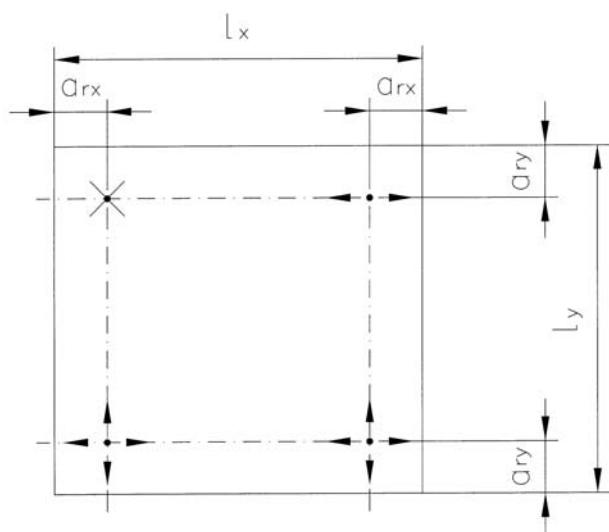

**legend**

- $a_{r,x,y}$  = edge distance – distance of an anchor to the panel edge
- $a_{x,y}$  = spacing - distance between anchors
- $L_x$  = greater length of the façade panel
- $L_y$  = smaller length of the façade panel
- X = fixed point (fixed bearing)
- ↔ = horizontal skid (loose bearing)
- ↕ = horizontal and vertical skid (loose bearing)

KEIL undercur anchor KH for mineralit® - façade panels

Characteristic values for the design of the anchor and facade panel  
Definition of edge distance and spacing

Annex 5

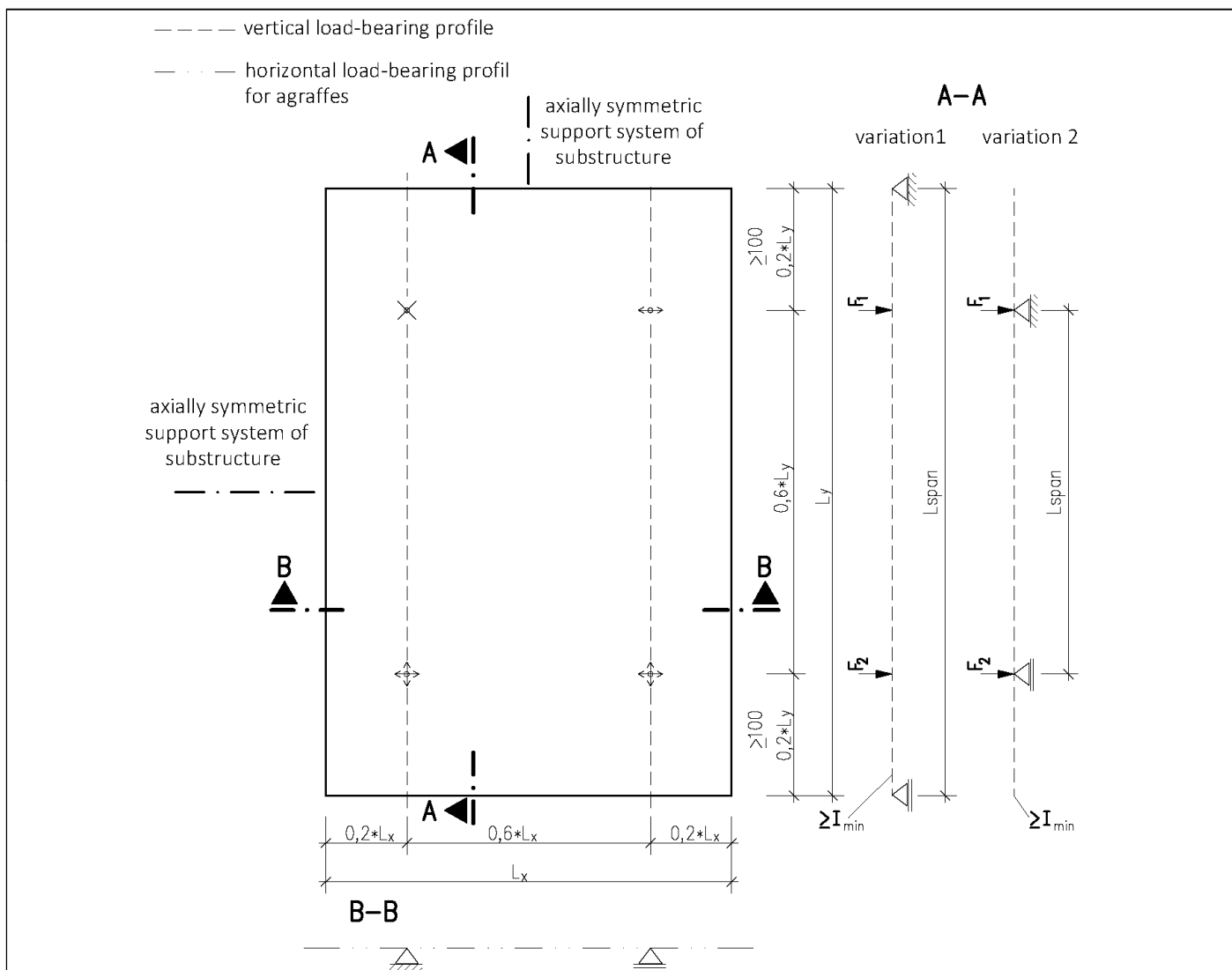

**Table 3: Characteristic resistance  $w_{Rk}$  to wind loads for support system A (4 anchors) and selected panel sizes**

$w_{Rk}$		$\gamma_m$	panel size $L_x \times L_y$ for proportion $L_x / L_y$ of		
suction [kN/m <sup>2</sup> ]	pressure [kN/m <sup>2</sup> ]		1/1 [m <sup>2</sup> ]	1/2 [m <sup>2</sup> ]	1/3 [m <sup>2</sup> ]
1.1	-1.5	2.0	2.25	2.25	1.92
1.7	-2.4		1.44	1.45	1.35
2.2	-3.3		1.10	0.98	1.01
3.0			1.21	1.13	1.08
4.8			0.71	0.72	0.66
6.6			0.48	0.46	0.43

- meaning of the symbols see Annex 5
- minimum requirements to the supporting substructure:
  - E- modulus of the agraffe  $\geq 70.000 \text{ N/mm}^2$
  - for span length  $L_{span}$  (vertical load-bearing profile)  $> 1 \text{ m}$ :  $I_{min} [\text{cm}^4]$  of supporting substructure =  $3 L_{span}^3$  ( $L_{span}$  in [m])

KEIL undercur anchor KH for mineralit® - façade panels

Characteristic resistance  $w_{Rk}$  to wind loads  
for support system A (4 anchors) and selected panel sizes

Annex 6

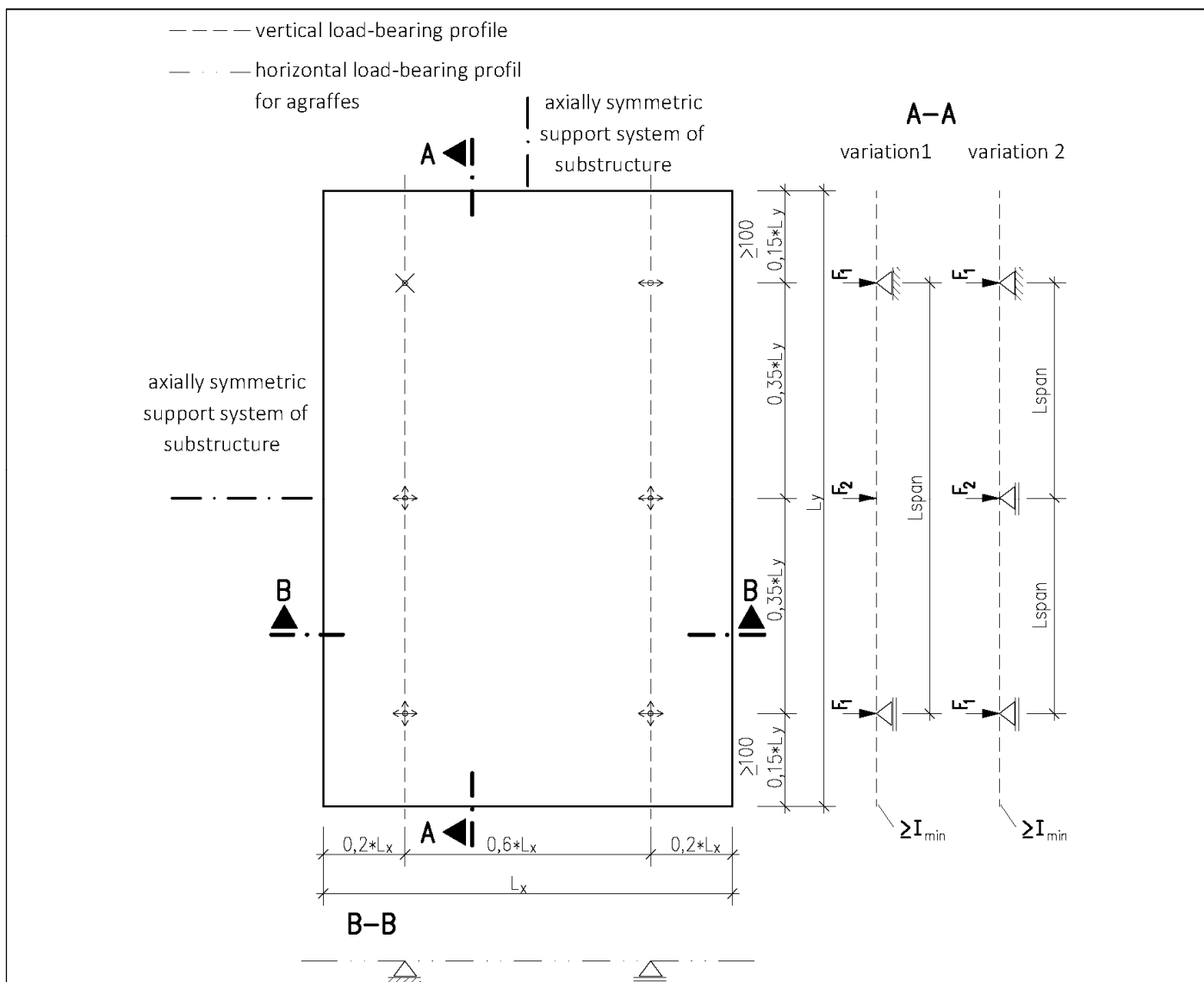

**Table 4: Characteristic resistance  $w_{Rk}$  to wind loads for support system B (6 anchors) and selected panel sizes**

$w_{Rk}$		$\gamma_M$	plate size $L_x \times L_y$ for proportion $L_x / L_y$ of		
suction [kN/m <sup>2</sup> ]	pressure [kN/m <sup>2</sup> ]		1/1 [m <sup>2</sup> ]	1/2 [m <sup>2</sup> ]	1/3 [m <sup>2</sup> ]
1.7	-2.4	2.0	2.25	2.42	2.43
2.2	-3.3		1.69	2.00	1.83
3.0			1.74	1.77	1.78
4.8			1.10	1.20	1.19
6.6			0.79	0.90	0.91

- meaning of the symbols see Annex 5
- minimum requirements to the supporting substructure:
  - E- modulus of the agraffe  $\geq 70.000 \text{ N/mm}^2$
  - for span length  $L_{span}$  (vertical load-bearing profile)  $> 1 \text{ m}$ :  $I_{min} [\text{cm}^4]$  of supporting substructure =  $3 L_{span}^3$  ( $L_{span}$  in [m])

KEIL undercur anchor KH for mineralit® - façade panels

Characteristic resistance  $w_{Rk}$  to wind loads  
for support system B (6 anchors) and selected panel sizes

Annex 7



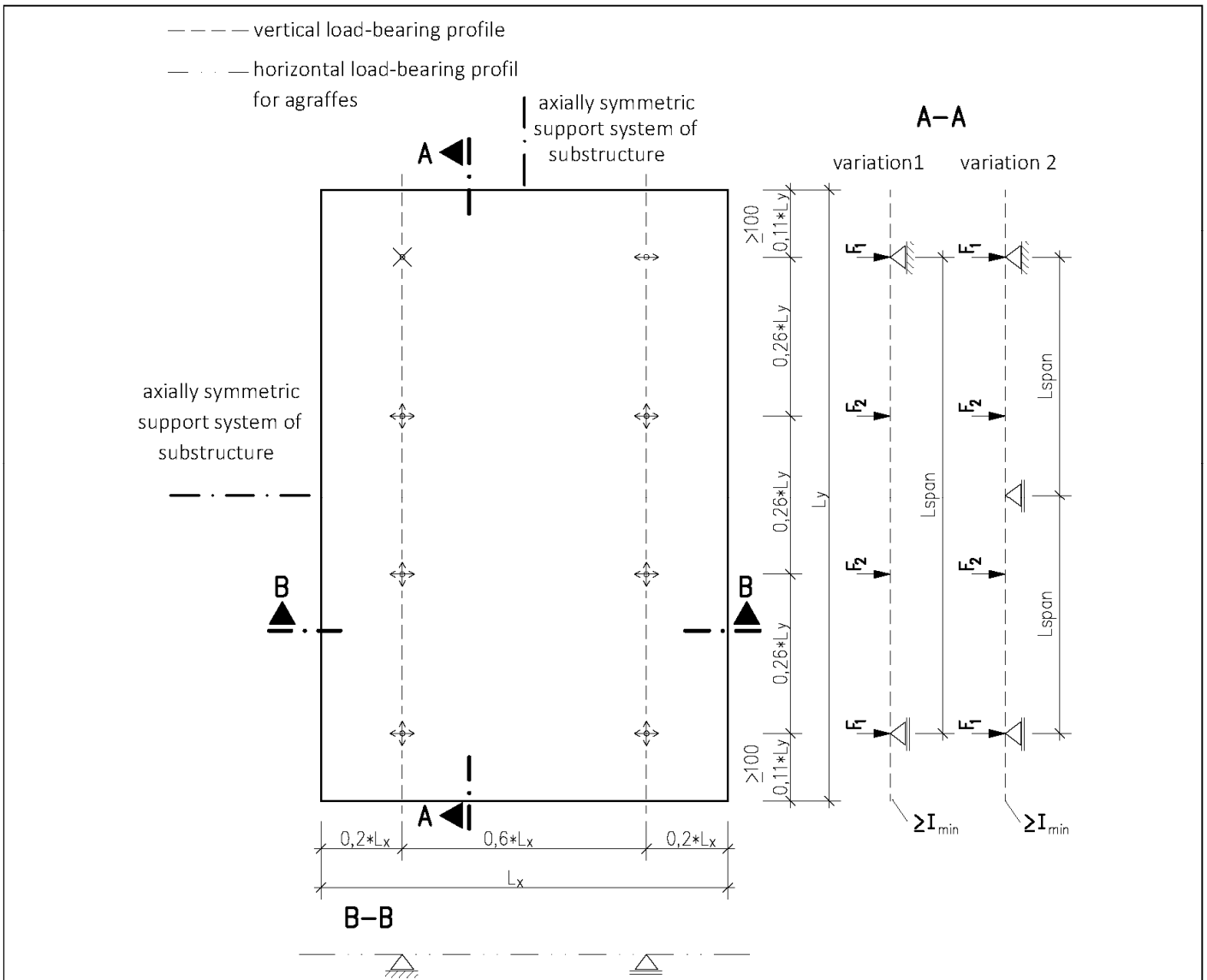

**Table 5: Characteristic resistance  $w_{Rk}$  to wind loads for support system C (8 anchors) and selected panel sizes**

$w_{Rk}$		$\gamma_m$	plate size $L_x \times L_y$ for proportion $L_x / L_y$ of		
suction	pressure		1/1	1/2	1/3
[kN/m <sup>2</sup> ]	[kN/m <sup>2</sup> ]	[-]	[m <sup>2</sup> ]	[m <sup>2</sup> ]	[m <sup>2</sup> ]
2.2	-3.3	2.0	2.10	2.42	2.43
3.0			2.13	2.25	2.22
4.8			1.32	1.55	1.56
6.6			0.94	1.19	1.19

- meaning of the symbols see Annex 5
- minimum requirements to the supporting substructure:
  - E- modulus of the agraffe  $\geq 70.000 \text{ N/mm}^2$
  - for span length  $L_{span}$  (vertical load-bearing profile)  $> 1 \text{ m}$ :  $I_{min} [\text{cm}^4]$  of supporting substructure =  $3 L_{span}^3$  ( $L_{span}$  in [m])

KEIL undercur anchor KH for mineralit® - façade panels

Characteristic resistance  $w_{Rk}$  to wind loads for support system C (8 anchors) and selected panel sizes

Annex 8

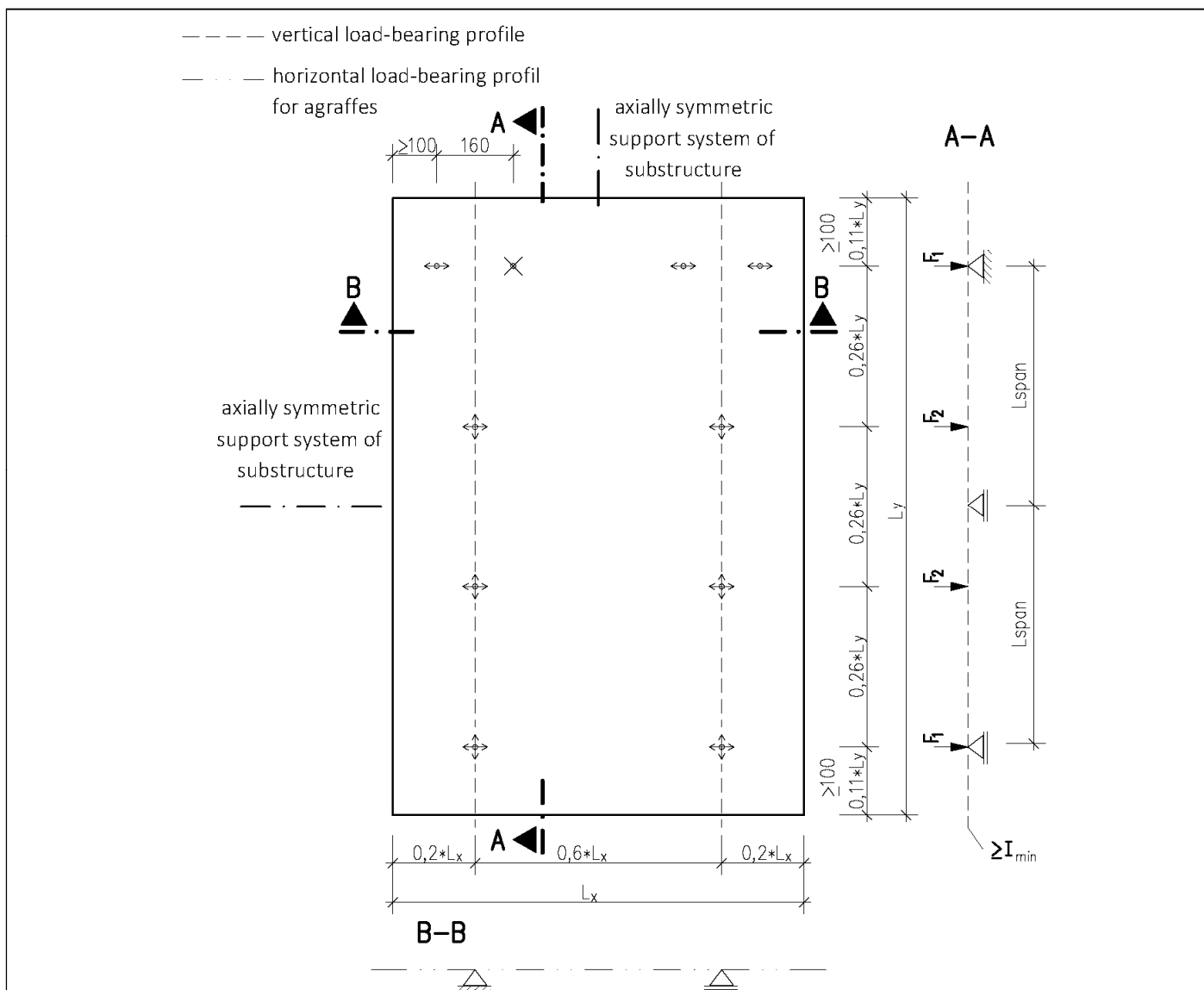

Table 6: Characteristic resistance  $w_{Rk}$  to wind loads for support system D (10 anchors) and selected panel sizes

$w_{Rk}$		$\gamma_M$	plate size $L_x \times L_y$ for proportion $L_x / L_y$ of		
suction	pressure		1/1	1/2	1/3
[kN/m <sup>2</sup> ]	[kN/m <sup>2</sup> ]	[-]	[m <sup>2</sup> ]	[m <sup>2</sup> ]	[m <sup>2</sup> ]
3.0	-3.3	2.0	2.25	2.42	2.43

- meaning of the symbols see Annex 5
- minimum requirements to the supporting substructure:
  - E- modulus of the agraffe  $\geq 70.000 \text{ N/mm}^2$
  - for span length  $L_{span}$  (vertical load-bearing profile)  $> 1 \text{ m}$ :  $I_{min} [\text{cm}^4]$  of supporting substructure =  $3 L_{span}^3$  ( $L_{span}$  in [m])

KEIL undercur anchor KH for mineralit® - façade panels

Characteristic resistance  $w_{Rk}$  to wind loads  
for support system D (10 anchors) and selected panel sizes

Annex 9

English translation prepared by DIBt

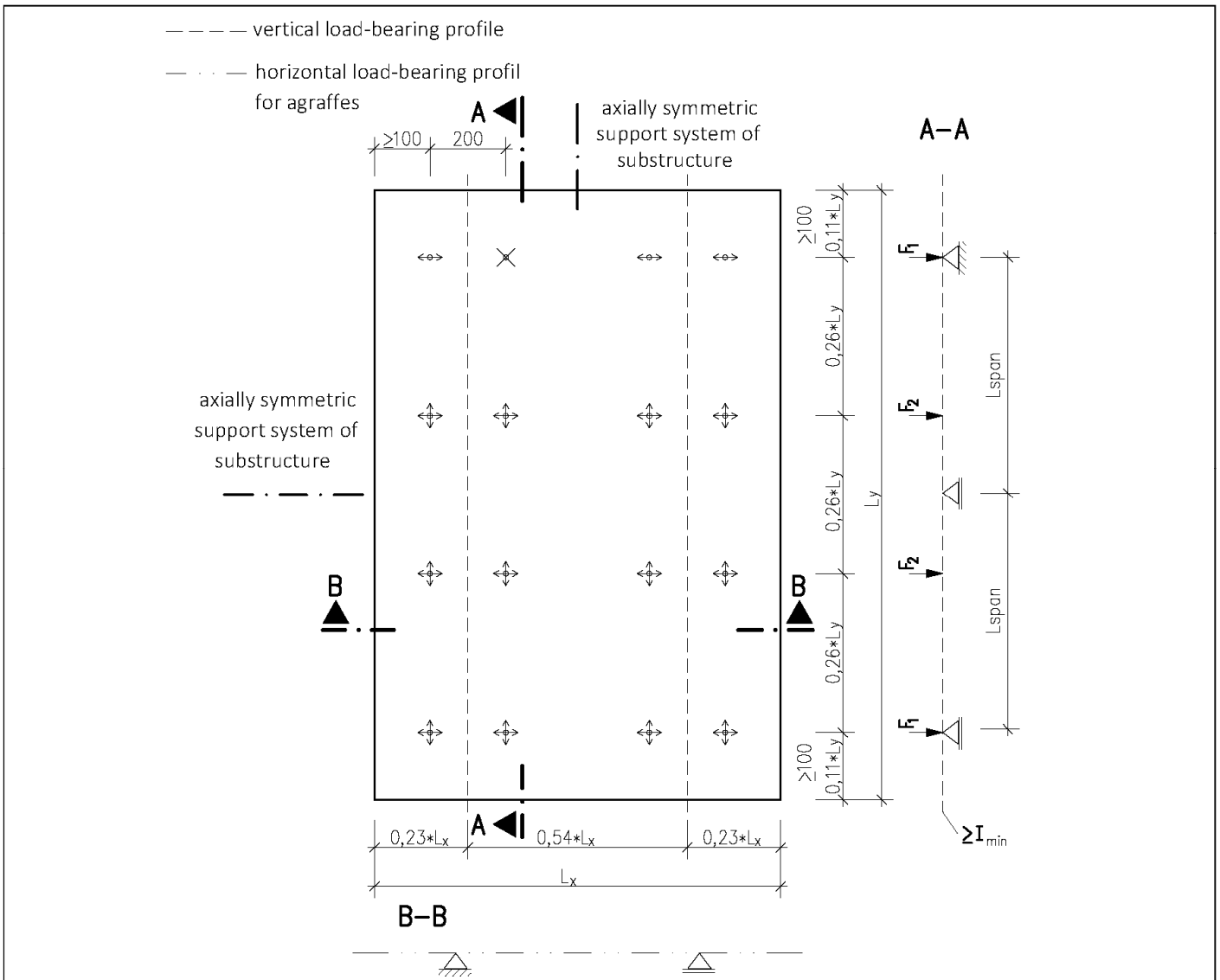

**Table 7: Characteristic resistance  $w_{Rk}$  to wind loads for support system E (16 anchors) and selected panel sizes**

$w_{Rk}$		$\gamma_m$	plate size $L_x \times L_y$ for proportion $L_x / L_y$ of		
suction	pressure		1/1	1/2	1/3
[kN/m <sup>2</sup> ]	[kN/m <sup>2</sup> ]	[-]	[m <sup>2</sup> ]	[m <sup>2</sup> ]	[m <sup>2</sup> ]
6.6	-3.3	2.0	2.25	2.42	2.43

- meaning of the symbols see Annex 5
- minimum requirements to the supporting substructure:
  - E- modulus of the agraffe  $\geq 70.000 \text{ N/mm}^2$
  - for span length  $L_{span}$  (vertical load-bearing profile)  $> 1 \text{ m}$ :  $I_{min} [\text{cm}^4]$  of supporting substructure =  $3 L_{span}^3$  ( $L_{span}$  in [m])

KEIL undercur anchor KH for mineralit® - façade panels	Annex 10
Characteristic resistance $w_{Rk}$ to wind loads for support system E (16 anchors) and selected panel sizes	

Electronic copy of the ETA by DIBt: ETA-06/0247