

## European Technical Approval ETA-08/0077

English translation prepared by DIBt - Original version in German language

Handelsbezeichnung  
*Trade name*

MAGE Flachdachbefestigungselemente  
*MAGE Flat Roof Fasteners*

Zulassungsinhaber  
*Holder of approval*

MAGE AG  
Industriestraße 34  
1791 Courtaman  
SCHWEIZ

Zulassungsgegenstand  
und Verwendungszweck  
*Generic type and use  
of construction product*

Befestigungselemente für Dachabdichtungssysteme  
*Fasteners for flexible roof waterproofing systems*

Geltungsdauer:  
*Validity:*

vom  
*from*  
bis  
*to*

4 April 2013  
4 April 2018

Herstellwerke  
*Manufacturing plants*

Werk 1, Werk 2  
Factory 1, factory 2

Diese Zulassung umfasst  
*This Approval contains*

29 Seiten einschließlich 23 Anhänge  
*29 pages including 23 annexes*

Diese Zulassung ersetzt  
*This Approval replaces*

ETA-08/0077 mit Geltungsdauer vom 05.08.2010 bis 03.04.2013  
*ETA-08/0077 with validity from 05.08.2010 to 03.04.2013*

## I LEGAL BASES AND GENERAL CONDITIONS

- 1 This European technical approval is issued by Deutsches Institut für Bautechnik in accordance with:
  - Council Directive 89/106/EEC of 21 December 1988 on the approximation of laws, regulations and administrative provisions of Member States relating to construction products<sup>1</sup>, modified by Council Directive 93/68/EEC<sup>2</sup> and Regulation (EC) N° 1882/2003 of the European Parliament and of the Council<sup>3</sup>;
  - *Gesetz über das In-Verkehr-Bringen von und den freien Warenverkehr mit Bauprodukten zur Umsetzung der Richtlinie 89/106/EWG des Rates vom 21. Dezember 1988 zur Angleichung der Rechts- und Verwaltungsvorschriften der Mitgliedstaaten über Bauprodukte und anderer Rechtsakte der Europäischen Gemeinschaften (Bauproduktengesetz - BauPG) vom 28. April 1998<sup>4</sup>, as amended by Article 2 of the law of 8 November 2011<sup>5</sup>;*
  - Common Procedural Rules for Requesting, Preparing and the Granting of European technical approvals set out in the Annex to Commission Decision 94/23/EC<sup>6</sup>;
  - Guideline for European technical approval of "Mechanically fastened flexible roof waterproofing membranes", ETAG 006.
- 2 Deutsches Institut für Bautechnik is authorized to check whether the provisions of this European technical approval are met. Checking may take place in the manufacturing plant. Nevertheless, the responsibility for the conformity of the products to the European technical approval and for their fitness for the intended use remains with the holder of the European technical approval.
- 3 This European technical approval is not to be transferred to manufacturers or agents of manufacturers other than those indicated on page 1, or manufacturing plants other than those indicated on page 1 of this European technical approval.
- 4 This European technical approval may be withdrawn by Deutsches Institut für Bautechnik, in particular pursuant to information by the Commission according to Article 5(1) of Council Directive 89/106/EEC.
- 5 Reproduction of this European technical approval including transmission by electronic means shall be in full. However, partial reproduction can be made with the written consent of Deutsches Institut für Bautechnik. In this case partial reproduction has to be designated as such. Texts and drawings of advertising brochures shall not contradict or misuse the European technical approval.
- 6 The European technical approval is issued by the approval body in its official language. This version corresponds fully to the version circulated within EOTA. Translations into other languages have to be designated as such.

<sup>1</sup> Official Journal of the European Communities L 40, 11 February 1989, p. 12  
<sup>2</sup> Official Journal of the European Communities L 220, 30 August 1993, p. 1  
<sup>3</sup> Official Journal of the European Union L 284, 31 October 2003, p. 25  
<sup>4</sup> *Bundesgesetzblatt Teil I 1998*, p. 812  
<sup>5</sup> *Bundesgesetzblatt Teil I 2011*, p. 2178  
<sup>6</sup> Official Journal of the European Communities L 17, 20 January 1994, p. 34

## II SPECIFIC CONDITIONS OF THE EUROPEAN TECHNICAL APPROVAL

### 1 Definition of the products and intended use

#### 1.1 Definition of the construction products

The construction products are mechanical fasteners. The fasteners comprise a screw made of coated carbon steel or stainless steel and a washer with or without integrated sleeve. The washers without integrated sleeve are made of coated carbon steel whereas the washers with integrated sleeve are made of plastic materials (polyamide, polypropylene).

#### 1.2 Intended use

The fasteners are intended to be used for the fastening of flexible roof waterproofing membranes according to ETAG 006. The possible substructures are steel decks or timber.

The provisions made in this European technical approval are based on an assumed working life of the fasteners of 10 years. The indications given on the working life cannot be interpreted as a guarantee given by the producer, but are to be regarded only as a means for choosing the right products in relation to the expected economically reasonable working life of the works.

In order to use the fasteners for systems of mechanically fastened flexible roof waterproofing membranes a separate ETA according to ETAG 006 is necessary for the entire roof waterproofing system.

### 2 Characteristics of the product and methods of verification

#### 2.1 Characteristics of the product

The fasteners shall correspond to the information given in Annexes 1 to 21.

The material properties, dimensions and tolerances not indicated in Annexes 1 to 21 shall correspond to the information laid down in the technical information<sup>7</sup> to this European technical approval.

#### 2.2 Safety in use (ER 4)

The characteristic values and mean values of the axial load resistance of the fasteners are given in Annexes 22 and 23. The values were determined by axial loading tests according to ETAG 006.

The fasteners are deemed to satisfy the requirements of ETAG 006 concerning unwinding. This was evaluated on the basis of the existing field experience of the manufacturer.

#### 2.3 Aspects of durability

The durability requirements of ETAG 006 (resistance to corrosion of metallic fasteners, impact resistance and brittleness of plastic fasteners before and after heat ageing, requirements for results of Charpy tests for plastic materials before and after heat ageing) are satisfied for the

<sup>7</sup> The technical documentation is deposited with Deutsches Institut für Bautechnik and as far as relevant for the tasks of the approved bodies involved in the attestation of conformity procedure is handed over to the approved bodies.

coated carbon steel, stainless steel and plastic materials (polyamide, polypropylene) components of the fasteners.

All coated carbon steel components resisted to 15 cycles of the test procedure described in ETAG 006 (Kesternich test) and did not show more than 15% surface corrosion.

The test results of the tests to check the impact resistance and brittleness of the polyamide and polypropylene components showed a drop height of more than 1,0 m before and after heat ageing of these components. Furthermore the results of the corresponding Charpy tests after heat ageing did not show any significant decline compared to the results before heat ageing.

### 3 Evaluation and attestation of conformity and CE marking

#### 3.1 System of attestation of conformity

According to the Decision 98/143/EC of the European Commission<sup>8</sup> the system 2+ of the attestation of conformity applies.

This system of attestation of conformity is defined as follows:

System 2+: Declaration of conformity of the products by the manufacturer on the basis of:

- (a) Tasks for the manufacturer:
  - (1) initial type-testing of the product;
  - (2) factory production control;
  - (3) testing of samples taken at the factory in accordance with a prescribed test plan.
- (b) Tasks for the approved body:
  - (4) certification of factory production control on the basis of:
    - initial inspection of factory and of factory production control;
    - continuous surveillance, assessment and approval of factory production control.

Note: Approved bodies are also referred to as "notified bodies".

#### 3.2 Responsibilities

##### 3.2.1 Tasks for the manufacturer

###### 3.2.1.1 Factory production control

The manufacturer shall exercise permanent internal control of production. All the elements, requirements and provisions adopted by the manufacturer shall be documented in a systematic manner in the form of written policies and procedures, including records of results performed. This production control system shall insure that the products are in conformity with this European technical approval.

The manufacturer may only use initial materials stated in the technical documentation of this European technical approval.

<sup>8</sup>

Official Journal of the European Communities L 42 of 14 February 1998

The factory production control shall be in accordance with the control plan, which is part of the technical documentation of this European technical approval. The control plan is laid down in the context of the factory production control system operated by the manufacturer and deposited with Deutsches Institut für Bautechnik.<sup>9</sup>

The results of factory production control shall be recorded and evaluated in accordance with the provisions of the control plan.

### 3.2.1.2 Other tasks for the manufacturer

The manufacturer shall, on the basis of a contract, involve a body which is approved for the tasks referred to in section 3.1 in the field of "Fasteners for flexible roof waterproofing membranes" in order to undertake the actions laid down in section 3.2.2. For this purpose, the control plan referred to in sections 3.2.1.1 and 3.2.2 shall be handed over by the manufacturer to the approved body involved.

The manufacturer shall make a declaration of conformity, stating that the construction products are in conformity with the provisions of this European technical approval.

### 3.2.2 Tasks for the approved bodies

The approved body shall perform the

- initial inspection of factory and of factory production control,
- continuous surveillance, assessment and approval of factory production control

in accordance with the provisions laid down in the control plan.

The approved body shall retain the essential points of its actions referred to above and state the results obtained and conclusions drawn in a written report.

The approved certification body involved by the manufacturer shall issue an EC certificate of conformity of the factory production control stating the conformity with the provisions of this European technical approval.

In cases where the provisions of the European technical approval and its control plan are no longer fulfilled the certification body shall withdraw the certificate of conformity and inform Deutsches Institut für Bautechnik without delay.

### 3.3 CE marking

The CE marking shall be affixed on each packaging of fasteners. The letters "CE" shall be followed by the identification number of the approved certification body, where relevant, and be accompanied by the following additional information:

- the name and address of the producer (legal entity responsible for the manufacture),
- the last two digits of the year in which the CE marking was affixed,
- the number of the EC certificate for the factory production control,
- the number of the European technical approval,
- the name of the product.

<sup>9</sup> The control plan is a confidential part of the European technical approval and only handed over to the approved body involved in the procedure of attestation of conformity. See section 3.2.2.

**4 Assumptions under which the fitness of the products for the intended use was favourably assessed**

**4.1 Manufacturing**

The European technical approval is issued for the product on the basis of agreed data/information, deposited with Deutsches Institut für Bautechnik, which identifies the product that has been assessed and judged. Changes to the product or production process, which could result in this deposited data/information being incorrect, should be notified to Deutsches Institut für Bautechnik before the changes are introduced. Deutsches Institut für Bautechnik will decide whether or not such changes affect the approval and consequently the validity of the CE marking on the basis of the approval and if so whether further assessment or alterations to the approval shall be necessary.

**4.2 Installation**

The installation is carried out according to the manufacturer's instructions. The manufacturer hands over the assembly instructions to the assembler.

In order to use the fasteners for systems of mechanically fastened flexible roof waterproofing membranes a valid ETA according to ETAG 006 is issued for the entire roof waterproofing system. The ETA according to ETAG 006 covers the wind uplift resistance of the entire system as well as the product characteristics of the components of the system.

The conformity of the installed fastener with this ETA is attested by the executing company.

**5 Indications to the manufacturer**

It is in the responsibility of the manufacturer to ensure that the information on the specific conditions according to 1, 2 and 4 is given to those who are concerned. The information may be given by reproduction of the European technical approval. In addition all installation data shall be shown clearly on the package and/or on an enclosed instruction sheet, preferably using illustration(s).

Georg Feistel  
Head of Department

*beglaubigt:*  
Spohn

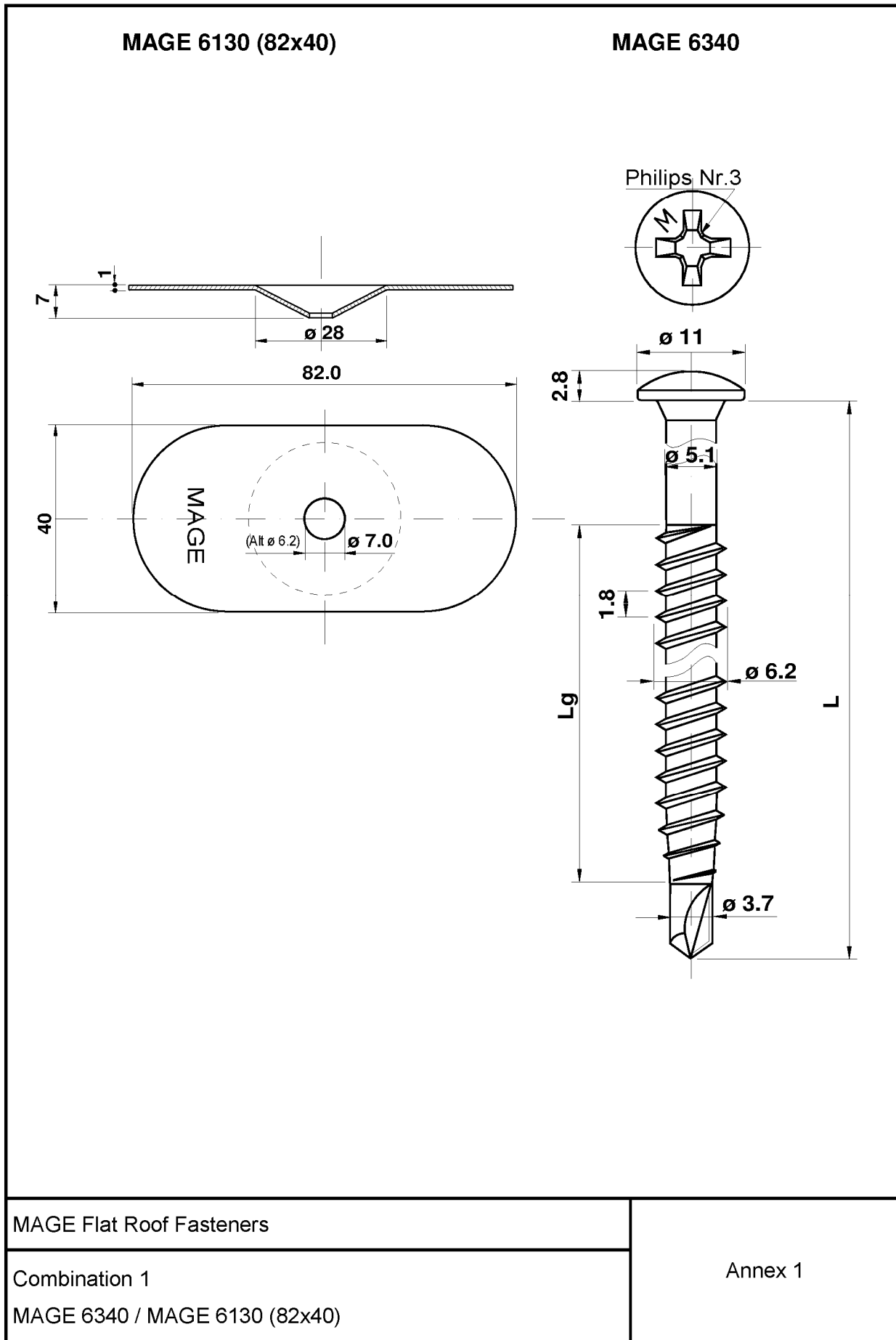

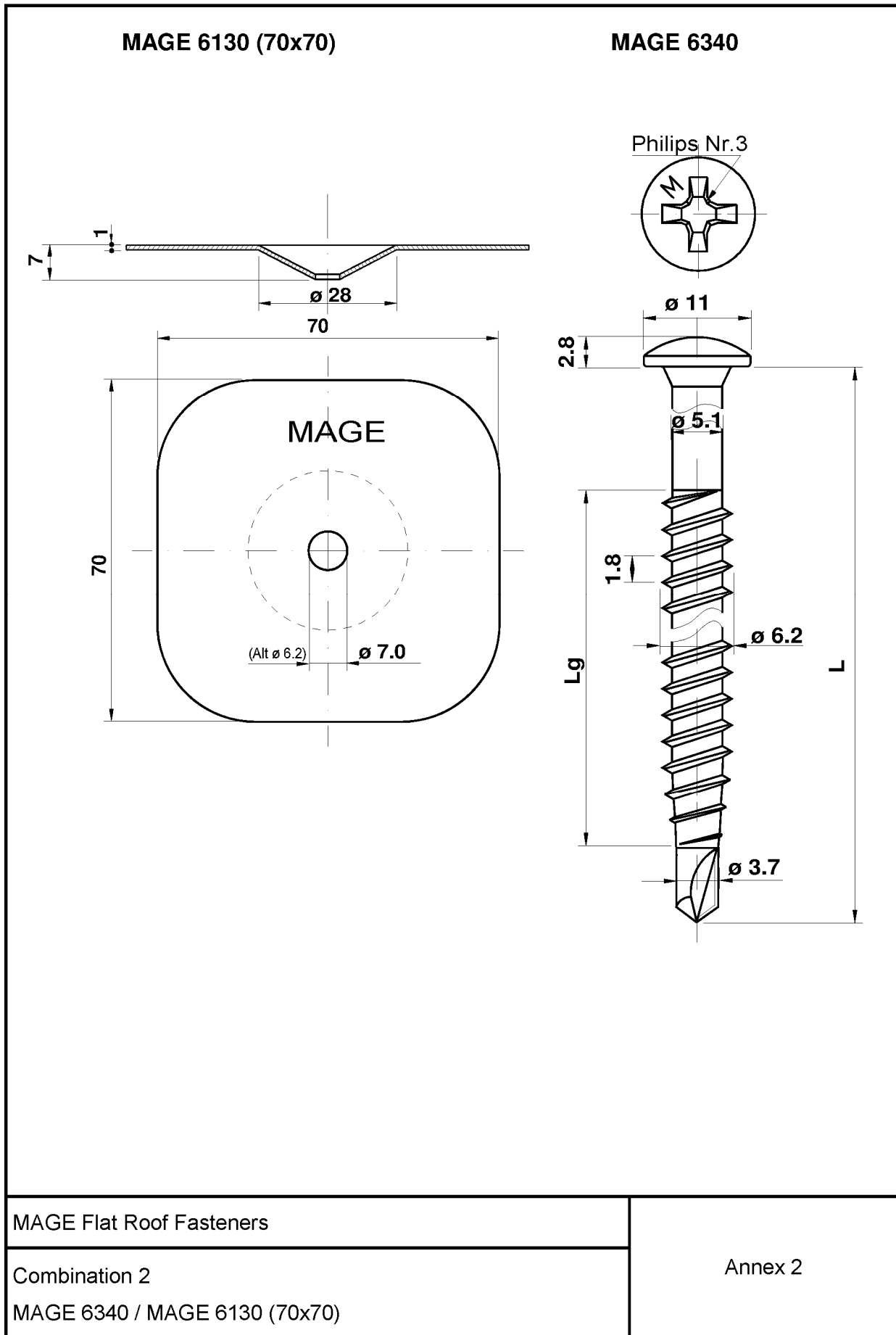



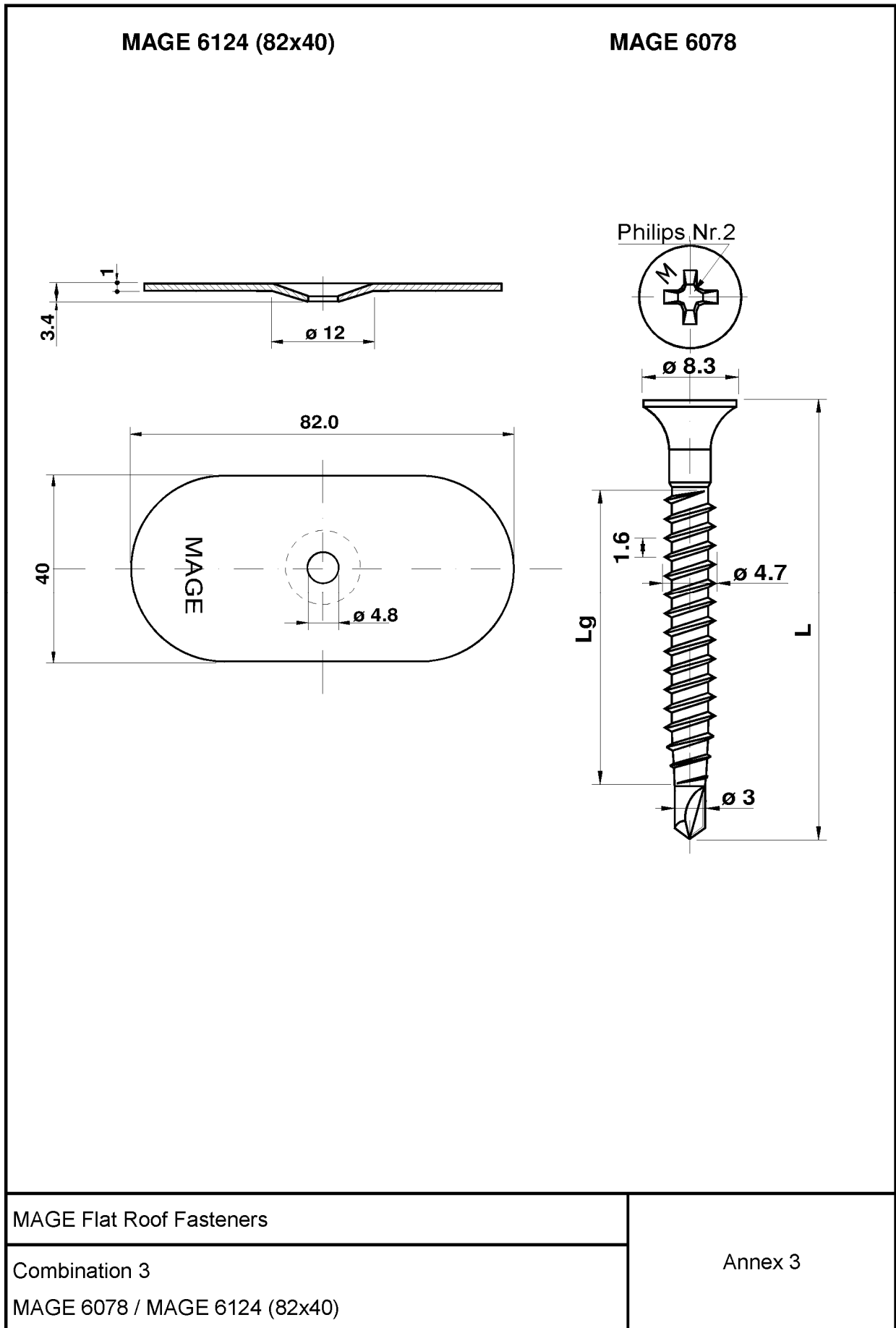

**MAGE PA 6133 (Ø80)**

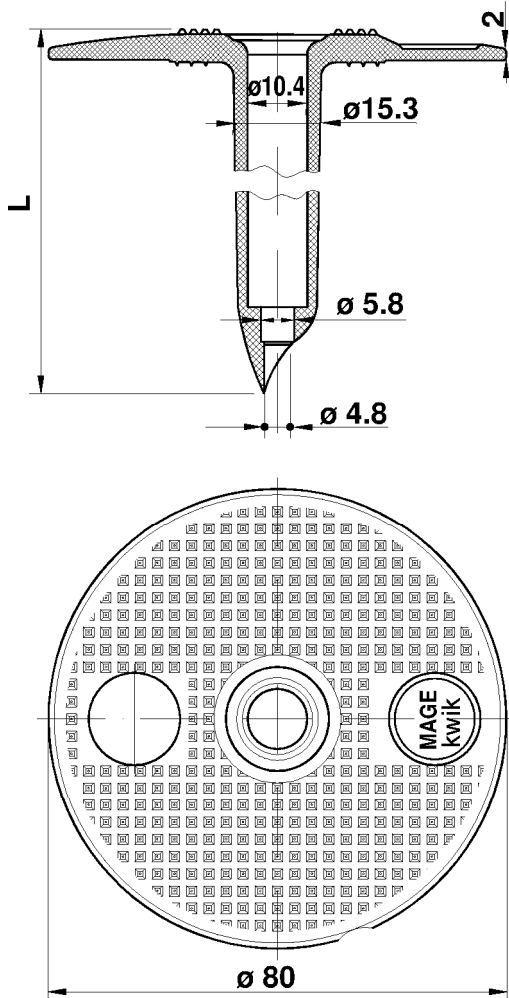

**MAGE 6097**

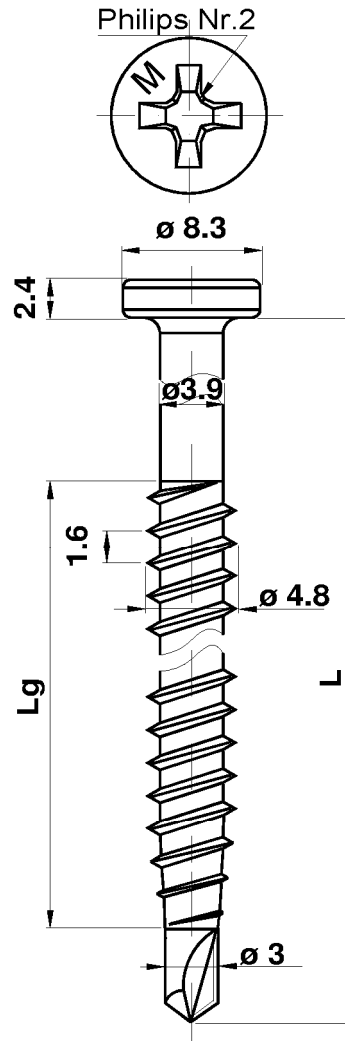

MAGE Flat Roof Fasteners

Combination 4

MAGE 6097 / MAGE PA 6133 (Ø80)

Annex 4

**MAGE PA 6134 (80x40)**

**MAGE 6097**

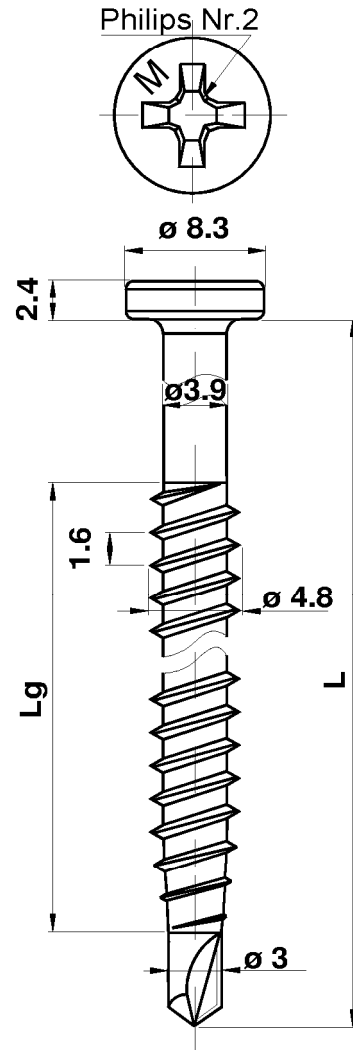
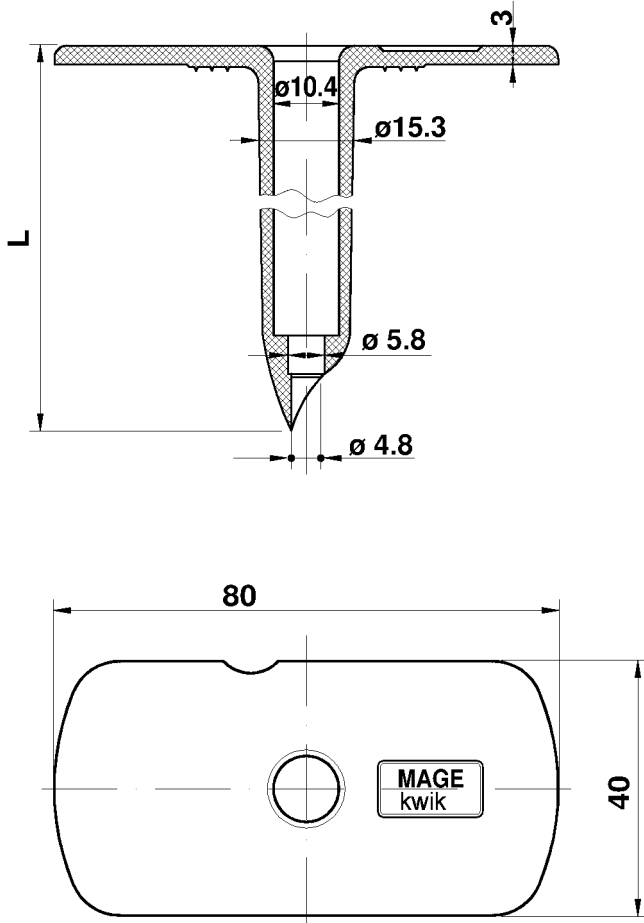

MAGE Flat Roof Fasteners

Combination 5

MAGE 6097 / MAGE PA 6134 (80x40)

Annex 5

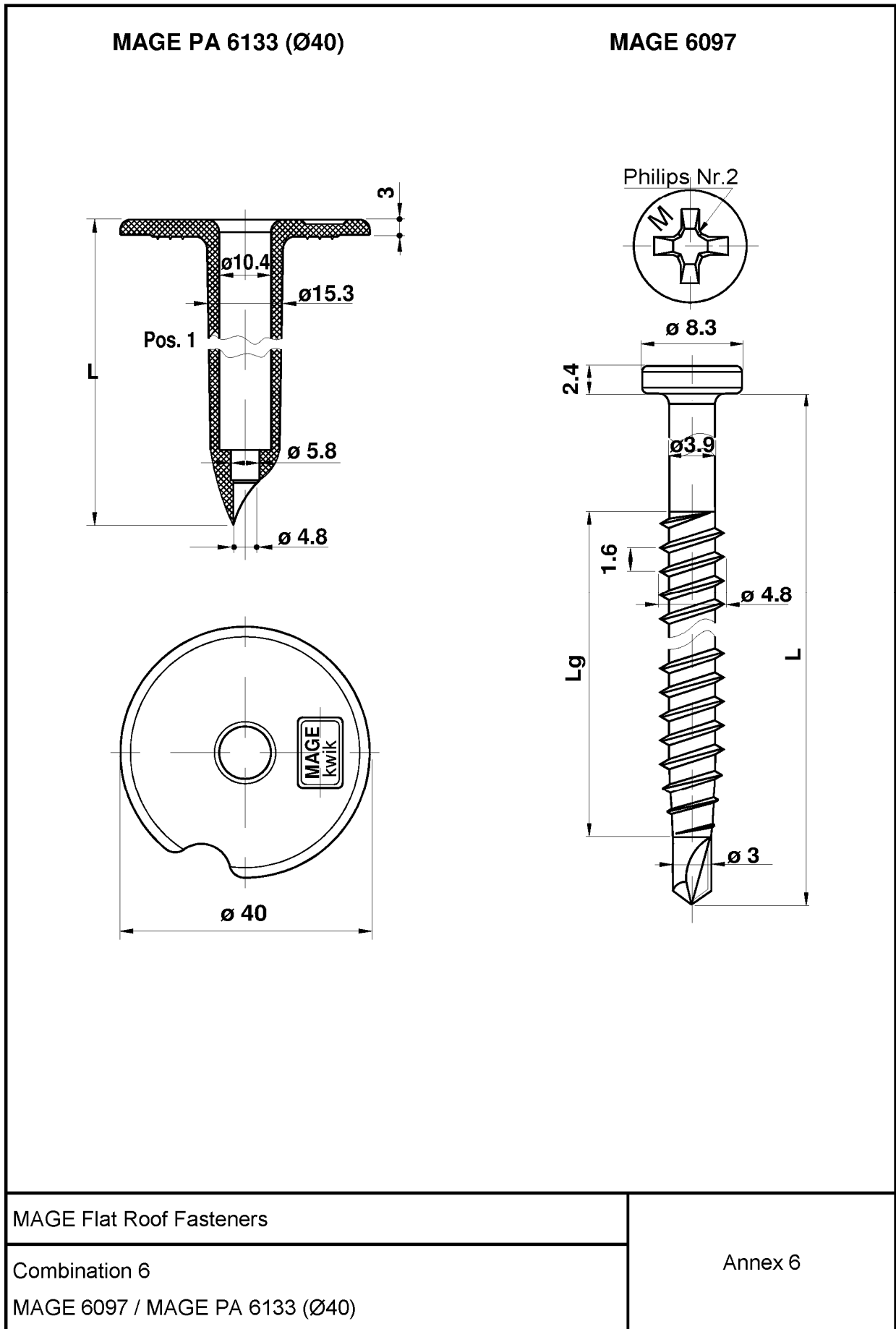

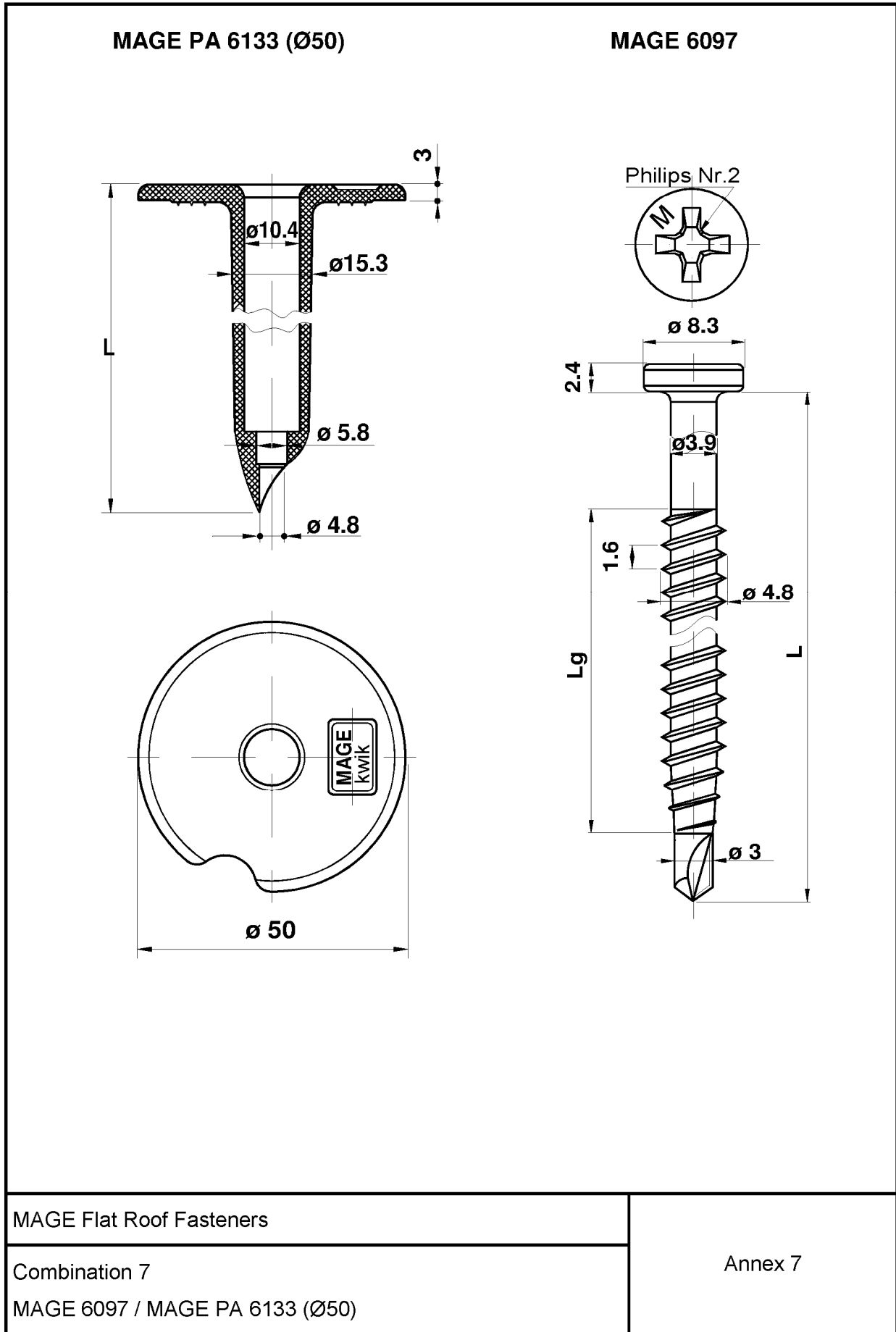

**MAGE PP 6134 (80x40)**

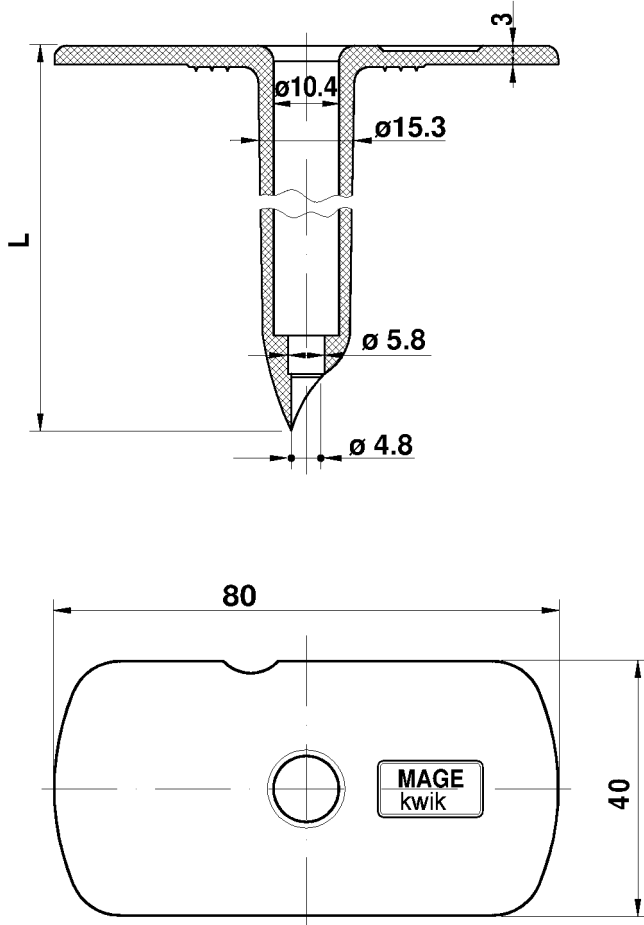

**MAGE 6097**

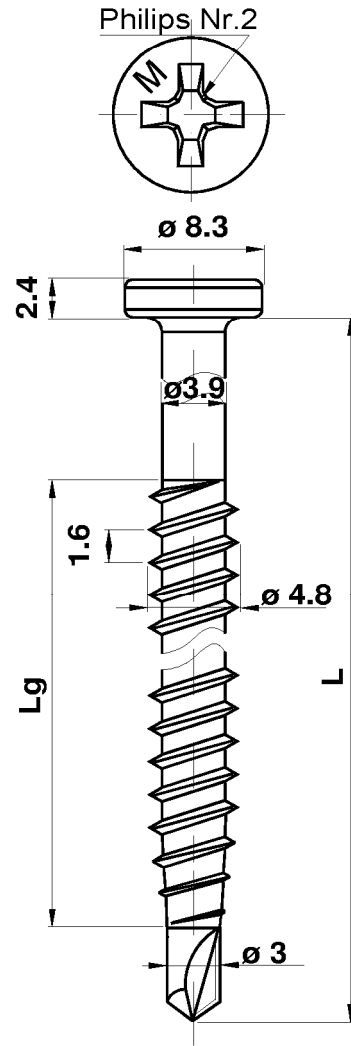

MAGE Flat Roof Fasteners

Combination 8

MAGE 6097 / MAGE PP 6134 (80x40)

Annex 8

**MAGE PP 6133 (Ø40)**

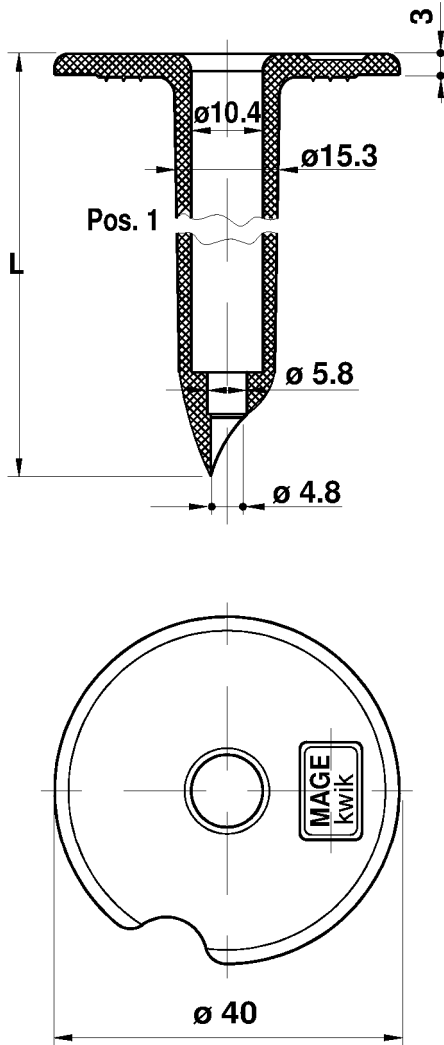

**MAGE 6097**

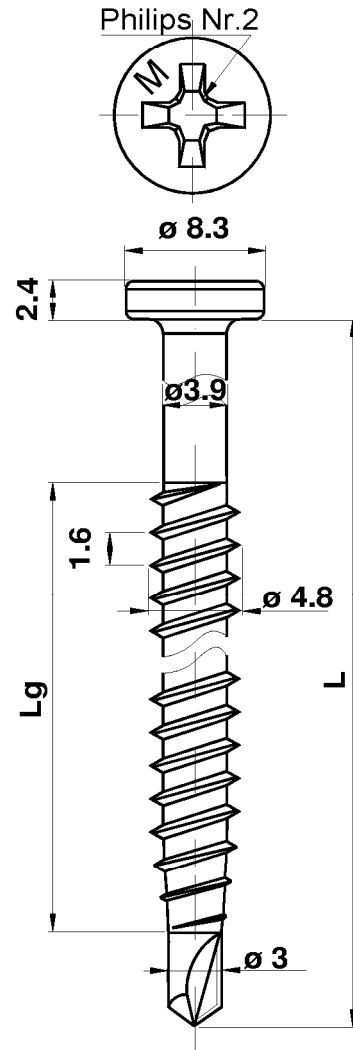

MAGE Flat Roof Fasteners

Combination 9

MAGE 6097 / MAGE PP 6133 (Ø40)

Annex 9

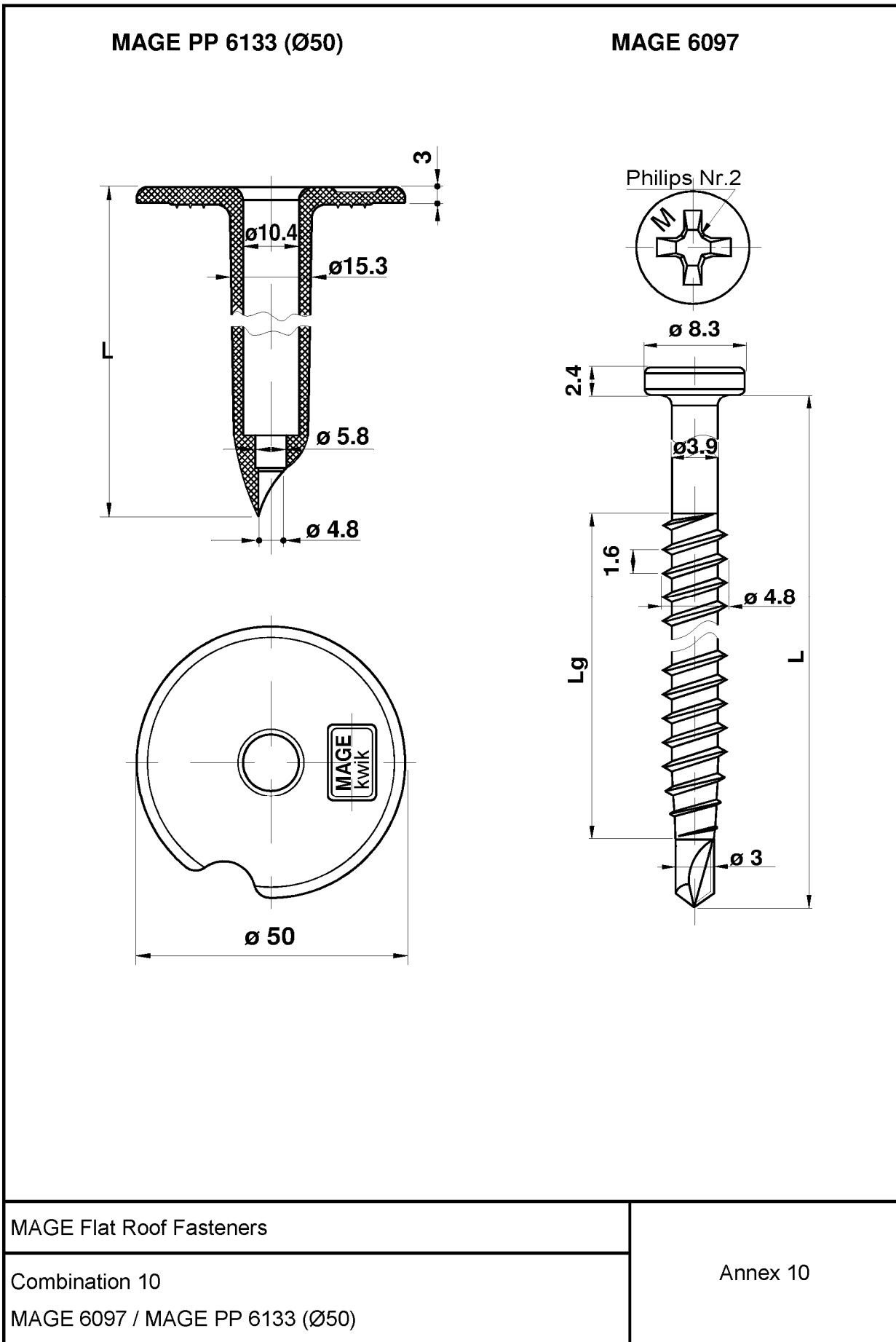



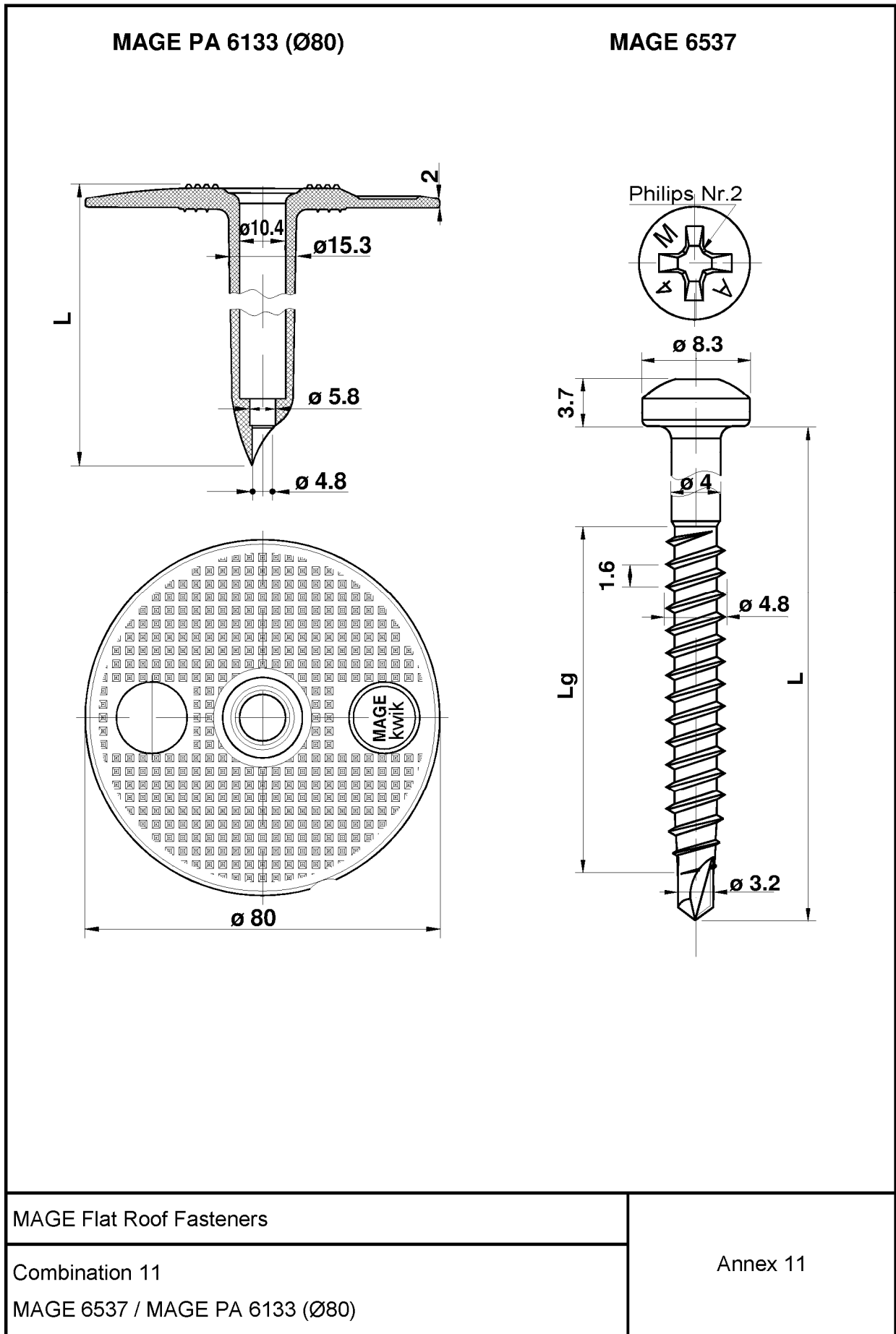

**MAGE PA 6134 (80x40)**

**MAGE 6537**

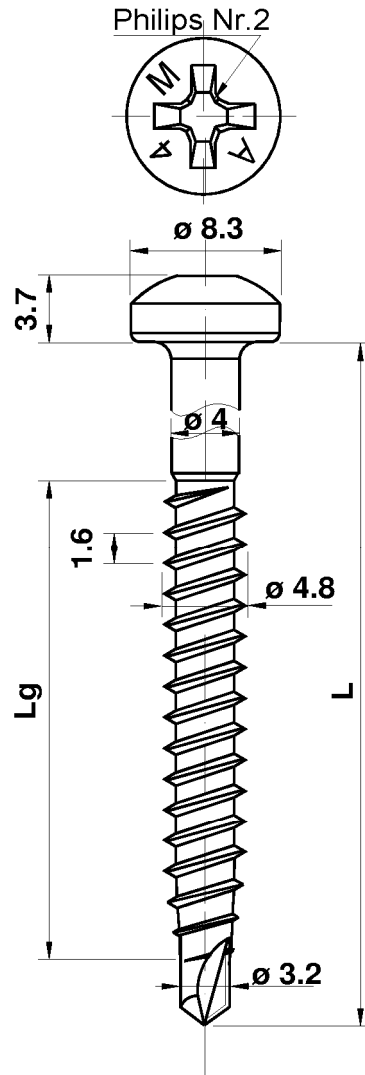
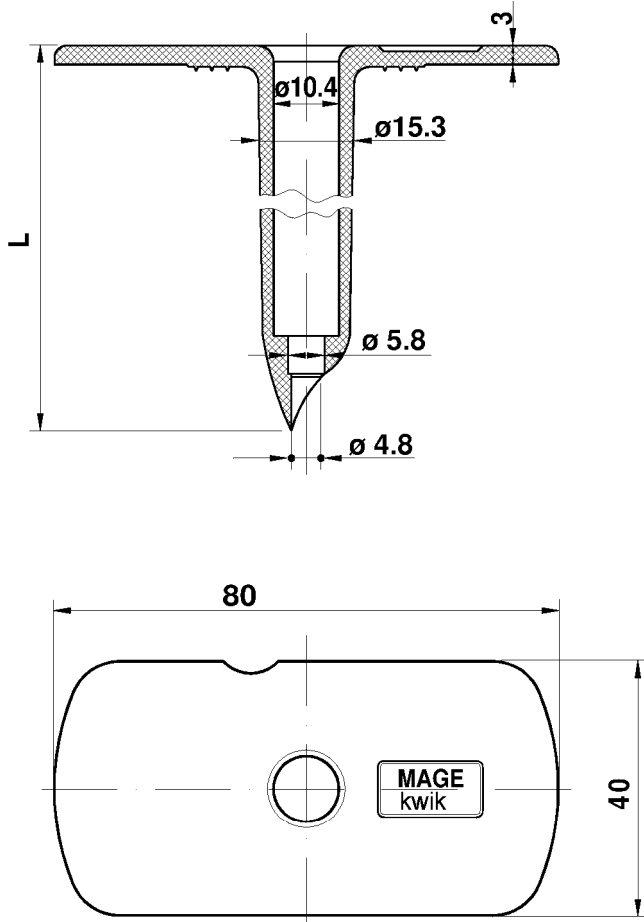

MAGE Flat Roof Fasteners

Combination 12

MAGE 6537 / MAGE PA 6134 (80x40)

Annex 12

**MAGE PA 6133 (Ø40)**

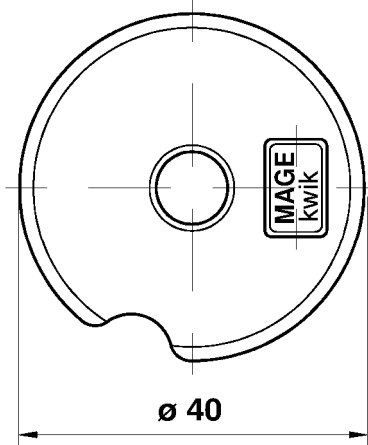
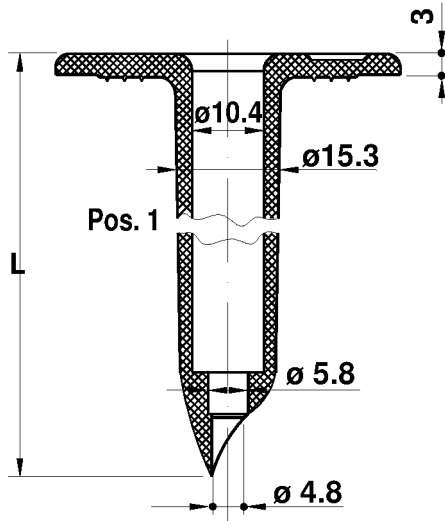

**MAGE 6537**

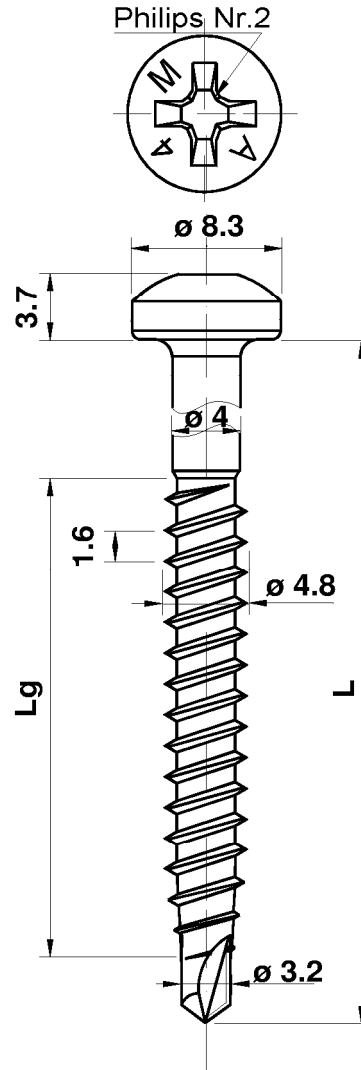

MAGE Flat Roof Fasteners

Combination 13

MAGE 6537 / MAGE PA 6133 (Ø40)

Annex 13

MAGE PA 6133 (Ø50)

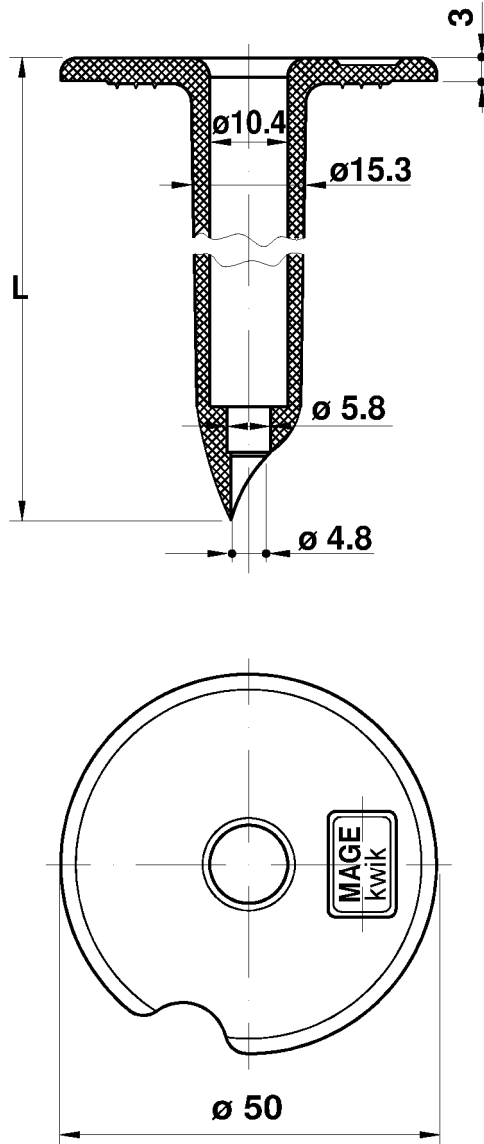

MAGE 6537

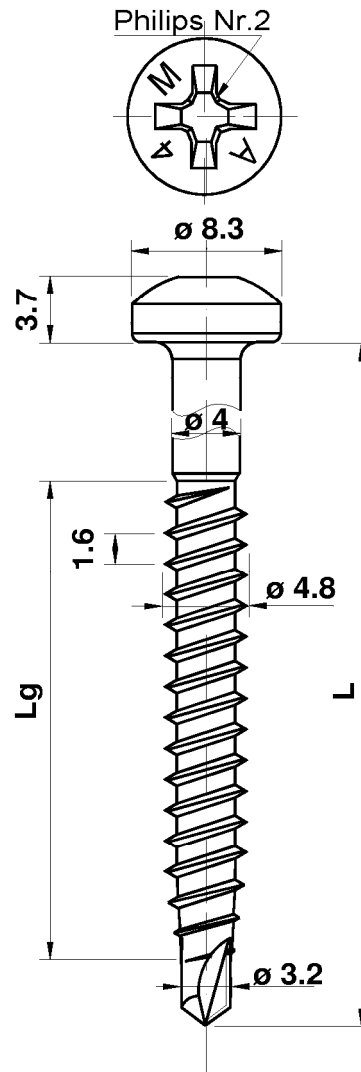

MAGE Flat Roof Fasteners

Combination 14

MAGE 6537 / MAGE PA 6133 (Ø50)

Annex 14

**MAGE PP 6134 (80x40)**

**MAGE 6537**

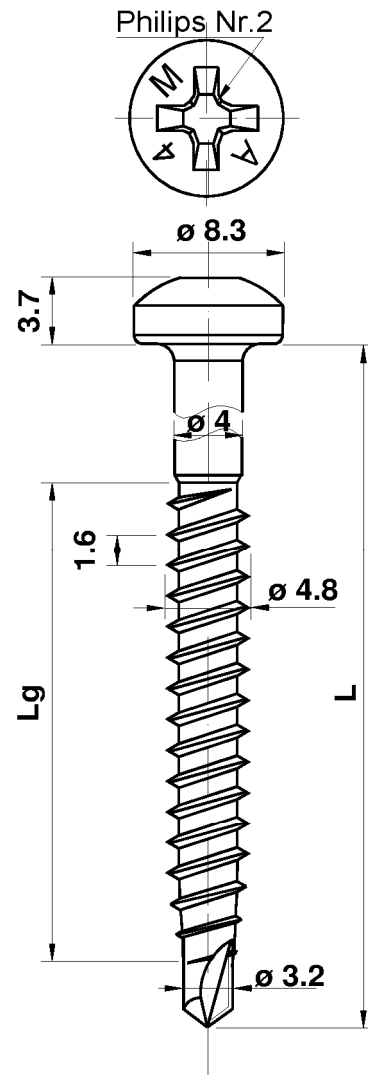
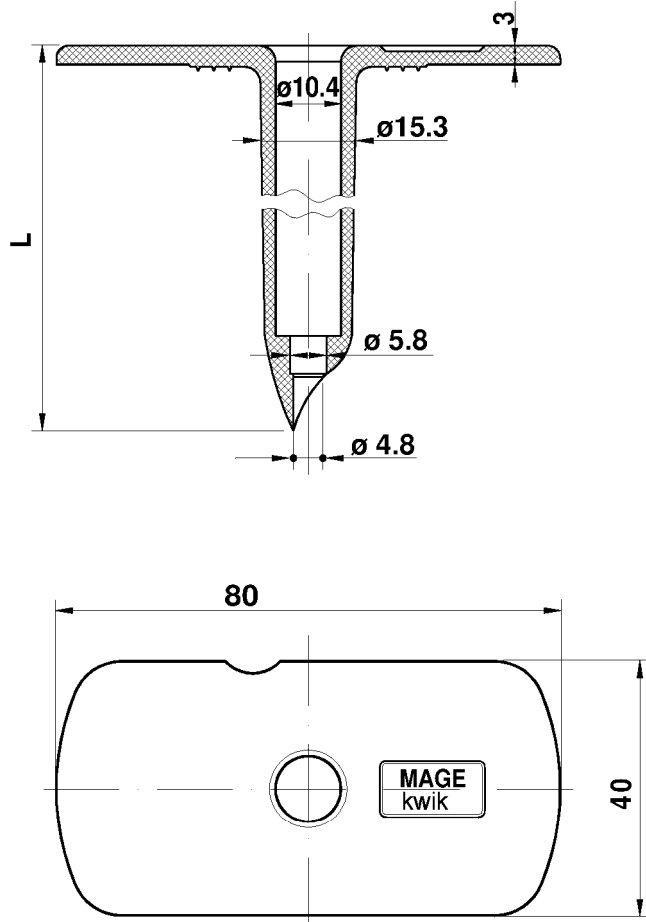

MAGE Flat Roof Fasteners

Combination 15

MAGE 6537 / MAGE PP 6134 (80x40)

Annex 15

MAGE PP 6133 (Ø40)

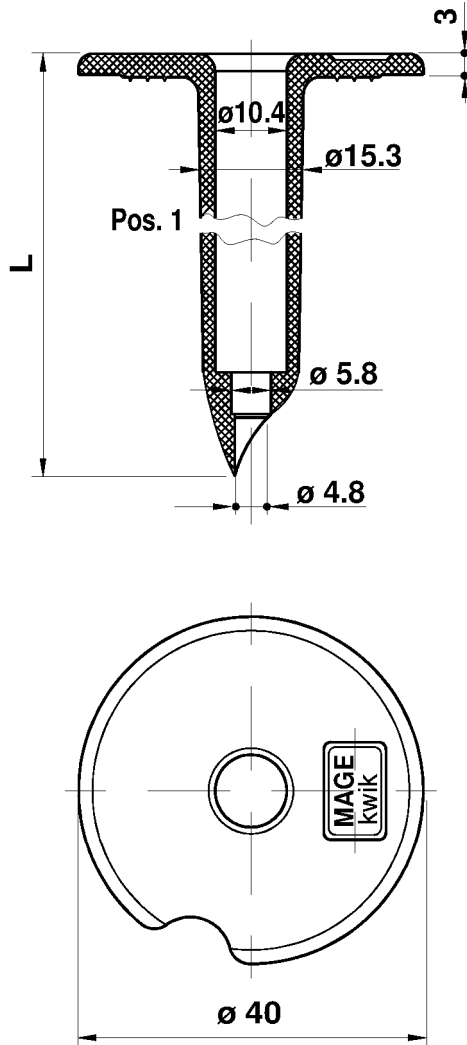

MAGE 6537

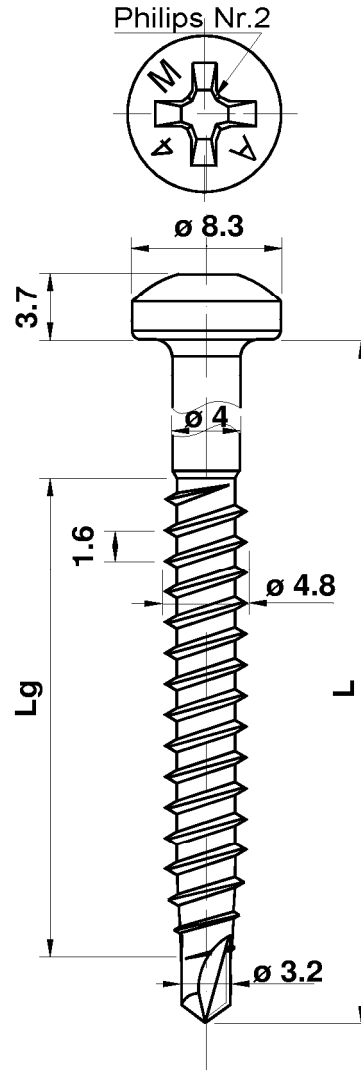

MAGE Flat Roof Fasteners

Combination 16

MAGE 6537 / MAGE PP 6133 (Ø40)

Annex 16

MAGE PP 6133 (Ø50)

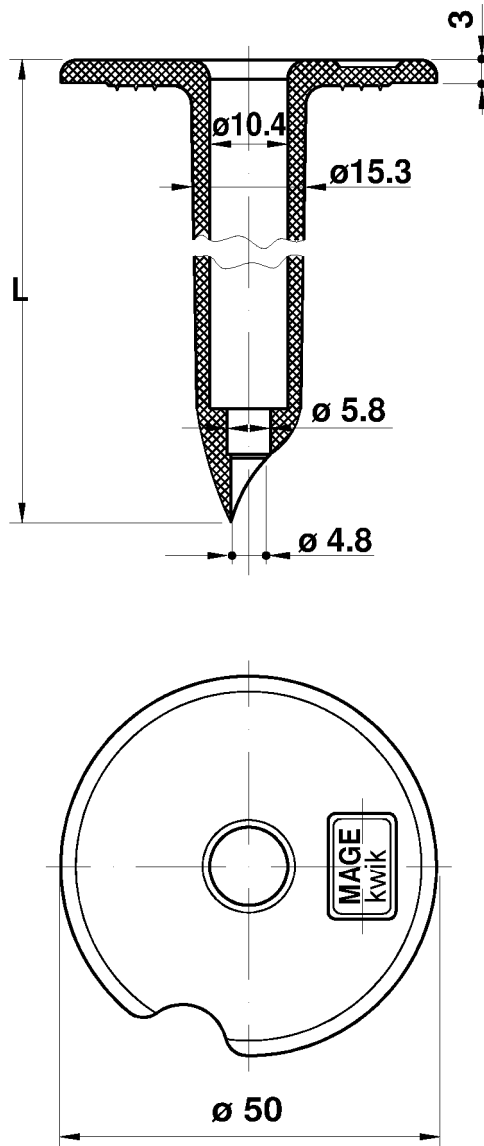

MAGE 6537

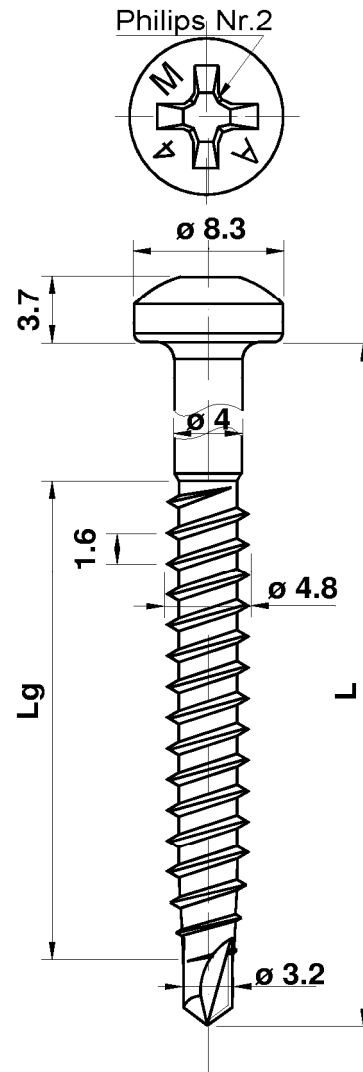

MAGE Flat Roof Fasteners

Combination 17

MAGE 6537 / MAGE PP 6133 (Ø50)

Annex 17

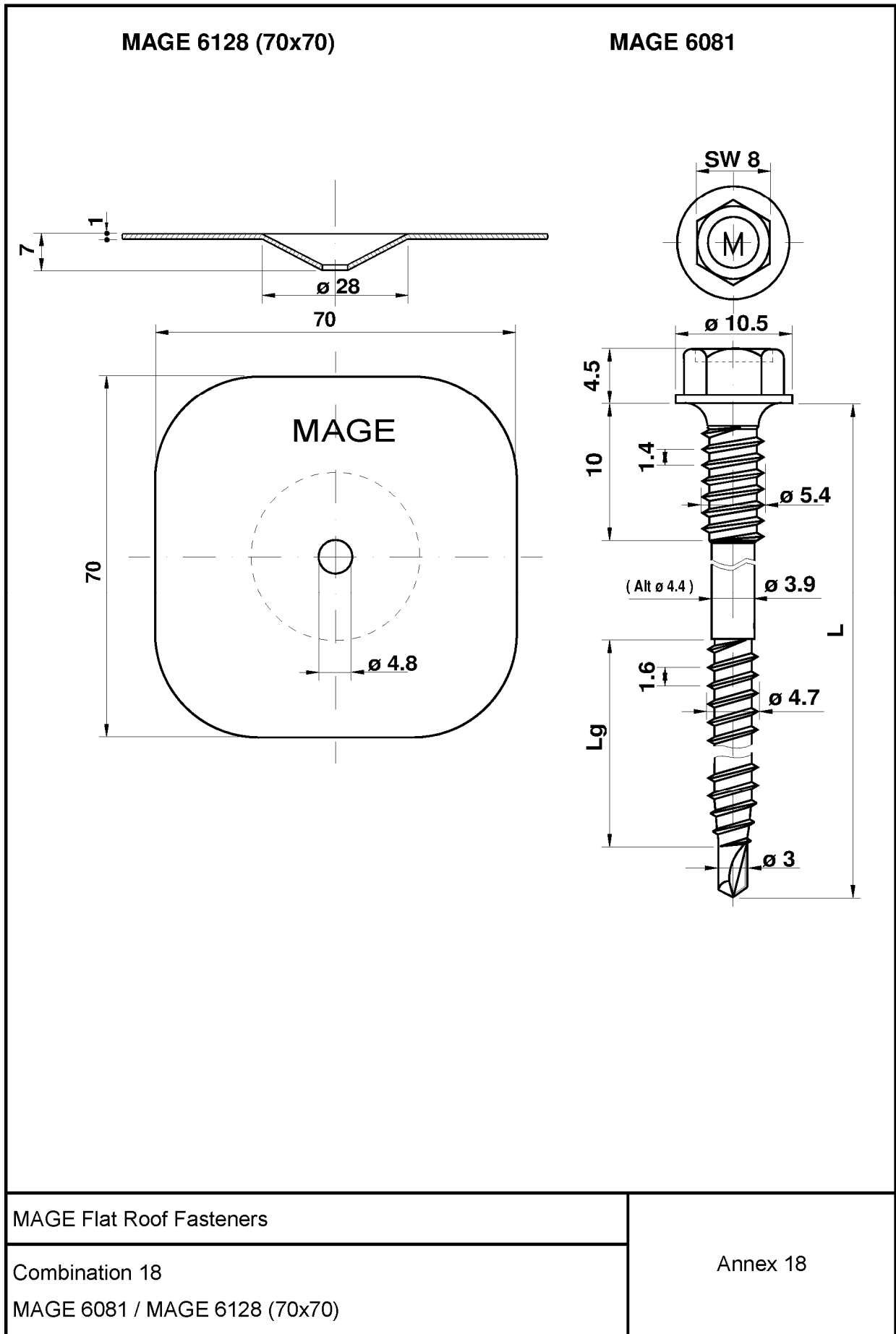



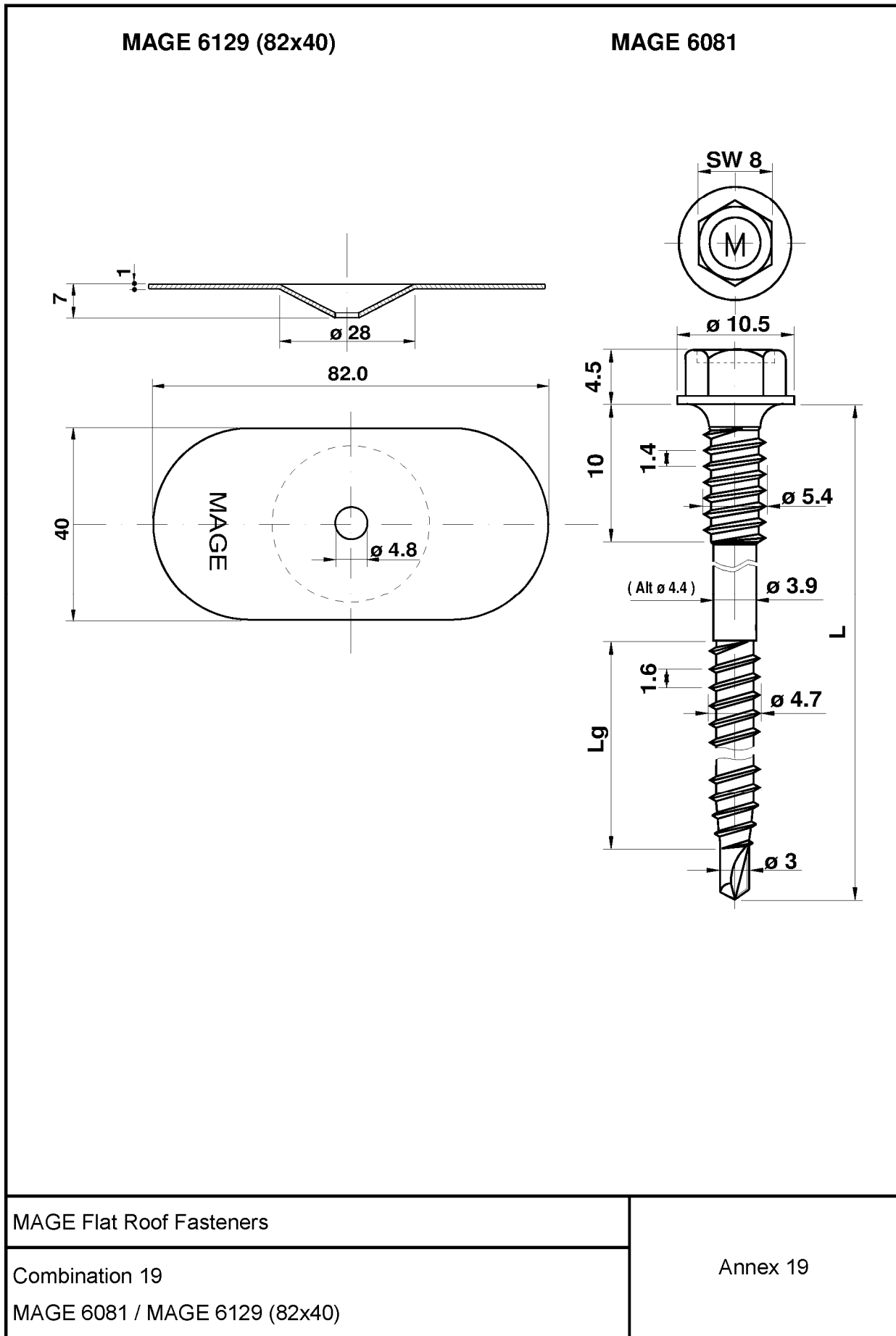

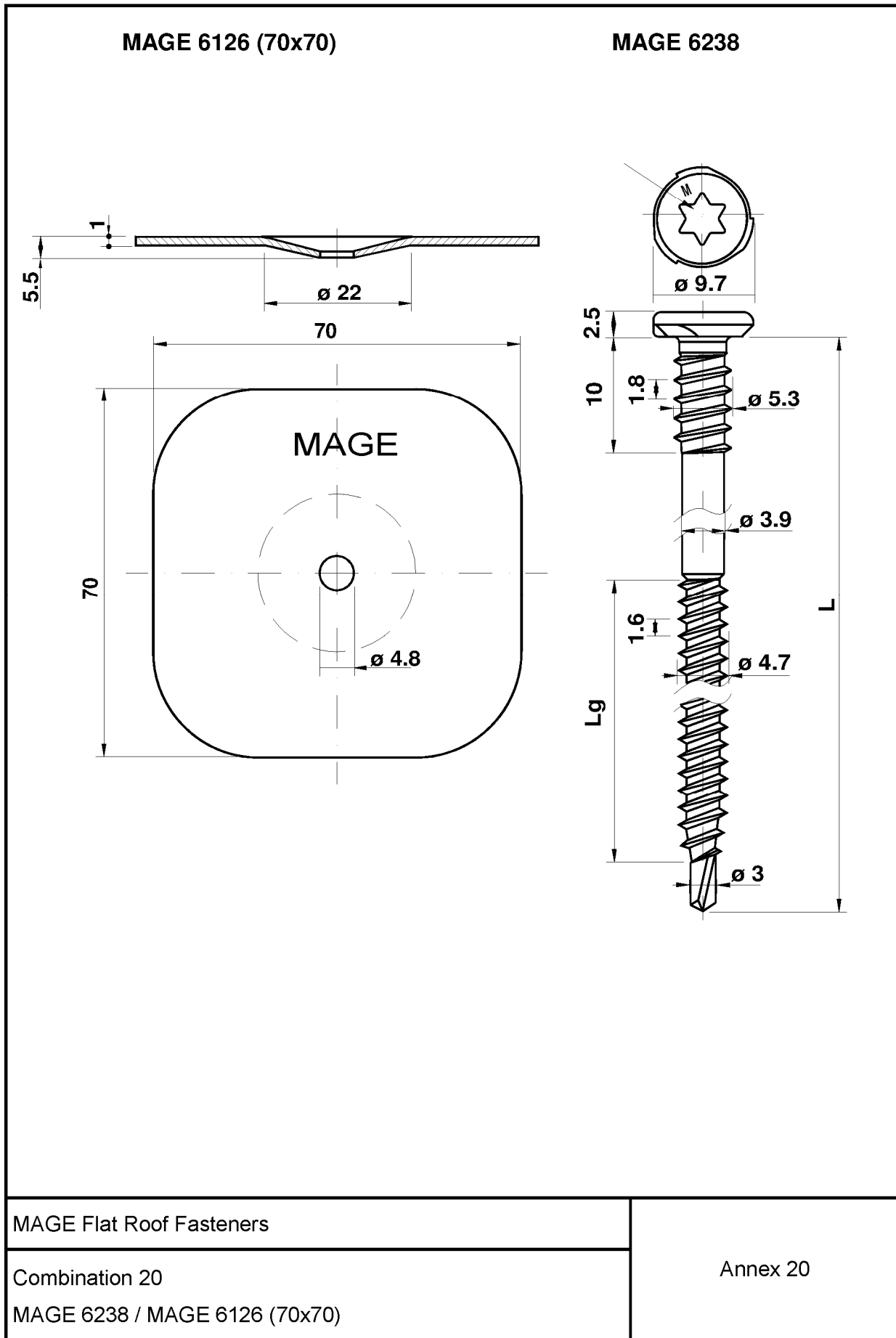

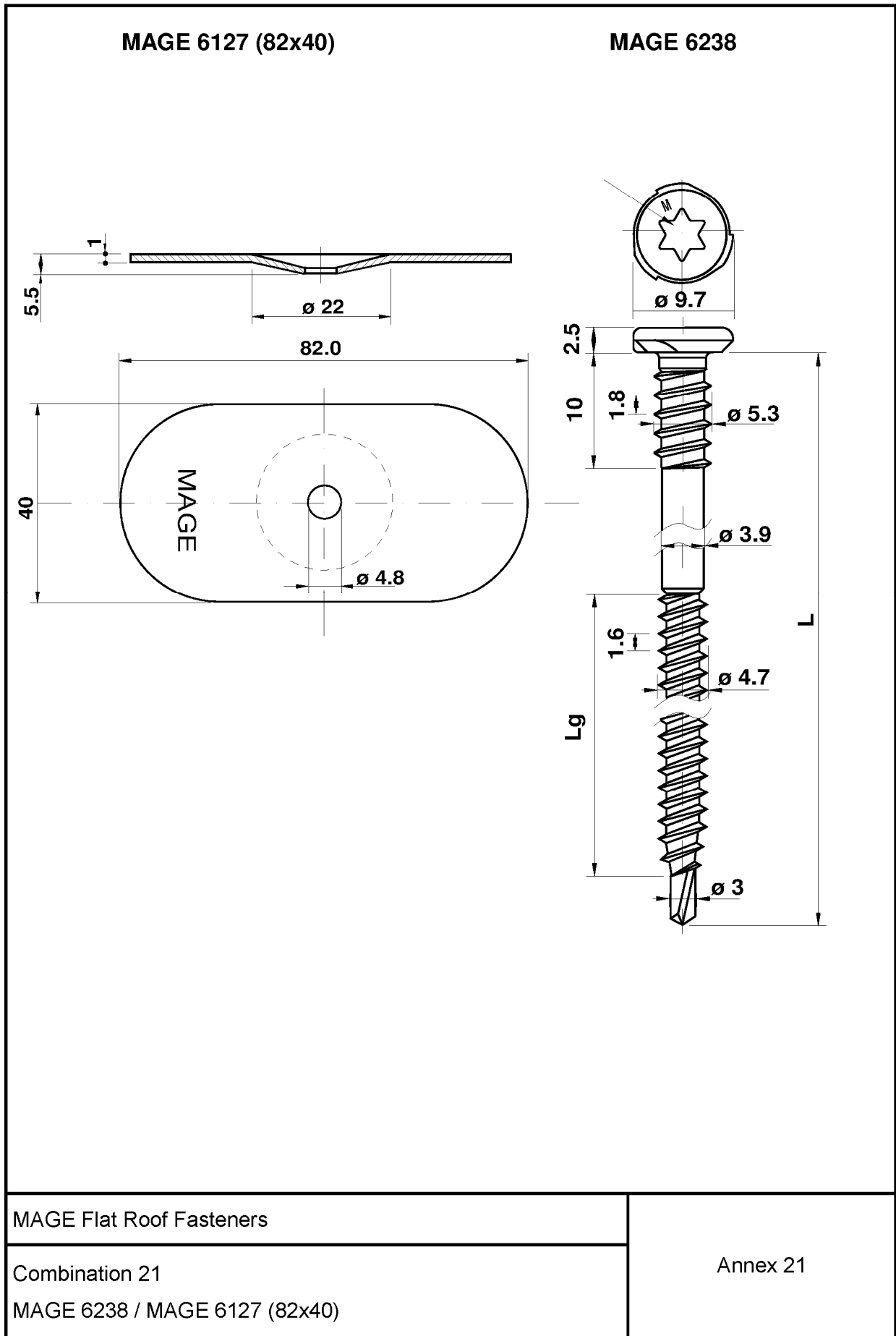

Characteristic Values of Axial Load Resistance [kN]								
Annex Nr.	MAGE Fastening Systems		Substructure					
			Steel sheets S280GD – EN 10346		Timber			
			t ≥ 0.63mm	t ≥ 2x0.63mm	OSB3 EN 300 t ≥ 18mm <sup>1)</sup>	Structural Timber EN 338 / C24		BFU100 EN 636 t ≥ 19mm <sup>4)</sup>
						t ≥ 30mm <sup>2)</sup>	t ≥ 22mm <sup>3)</sup>	
Screw	Washer							
1	6340	6130 (82x40)	0.87	0.87	1.58	3.15	2.26	1.65
2		6130 (70x70)	0.87	0.87	1.58	3.15	2.26	1.65
3	6078	6124 (82x40)	0.72	1.46	1.25	2.42	1.76	1.37
4	6097	PA 6133 (Ø80)	0.72	1.46	1.25	2.69	1.76	1.37
5		PA 6134 (80x40)	0.72	1.46	1.25	2.69	1.76	1.37
6		PA 6133 (Ø40)	0.72	1.46	1.25	1.93	1.76	1.37
7		PA 6133 (Ø50)	0.72	1.46	1.25	2.69	1.76	1.37
8		PP 6134 (80x40)	0.72	1.40	1.25	1.40	1.40	1.37
9		PP 6133 (Ø40)	0.72	1.46	1.25	1.47	1.47	1.37
10		PP 6133 (Ø50)	0.72	1.05	1.05	1.05	1.05	1.05
11		6537	PA 6133 (Ø80)	0.72	1.46	1.25	2.69	1.76
12	PA 6134 (80x40)		0.72	1.46	1.25	2.69	1.76	1.37
13	PA 6133 (Ø40)		0.72	1.46	1.25	1.93	1.76	1.37
14	PA 6133 (Ø50)		0.72	1.46	1.25	2.69	1.76	1.37
15	PP 6134 (80x40)		0.72	1.40	1.25	1.40	1.40	1.37
16	PP 6133 (Ø40)		0.72	1.46	1.25	1.47	1.47	1.37
17	PP 6133 (Ø50)		0.72	1.05	1.05	1.05	1.05	1.05
18	6081	6128 (70x70)	0.72	1.46	1.25	2.69	1.76	1.37
19		6129 (82x40)	0.72	1.46	1.25	2.69	1.76	1.37
20	6238	6126 (70x70)	0.72	1.46	1.25	2.69	1.76	1.37
21		6127 (82x40)	0.72	1.46	1.25	2.69	1.76	1.37
<sup>1)</sup> effective embedment depth (penetration length of threaded part) ≥ 18 mm <sup>2)</sup> effective embedment depth (penetration length of threaded part) ≥ 30 mm <sup>3)</sup> effective embedment depth (penetration length of threaded part) ≥ 22 mm <sup>4)</sup> effective embedment depth (penetration length of threaded part) ≥ 19 mm								
MAGE Flat Roof Fasteners						Annex 22		
Characteristic Values of Axial Load Resistance								

Mean Values of Axial Load Resistance [kN]								
Annex Nr.	MAGE Fastening Systems		Substructure					
			Steel sheets S280GD – EN 10346		Timber			
			t ≥ 0.63mm	t ≥ 2x0.63mm	OSB3 EN 300 t ≥ 18mm <sup>1)</sup>	Structural Timber EN 338 / C24		BFU100 EN 636 t ≥ 19mm <sup>4)</sup>
						t ≥ 30mm <sup>2)</sup>	t ≥ 22mm <sup>3)</sup>	
Screw	Washer							
1	6340	6130 (82x40)	1.15	1.15	2.18	6.12	3.28	3.33
2		6130 (70x70)	1.15	1.15	2.18	6.12	3.28	3.33
3	6078	6124 (82x40)	0.96	2.08	1.85	3.85	2.69	2.93
4	6097	PA 6133 (Ø80)	0.96	2.08	1.85	3.38	2.69	2.93
5		PA 6134 (80x40)	0.96	2.08	1.85	3.51	2.69	2.93
6		PA 6133 (Ø40)	0.96	2.01	1.85	2.01	2.01	2.01
7		PA 6133 (Ø50)	0.96	2.08	1.85	3.55	2.69	2.93
8		PP 6134 (80x40)	0.96	1.53	1.53	1.53	1.53	1.53
9		PP 6133 (Ø40)	0.96	1.53	1.53	1.53	1.53	1.53
10		PP 6133 (Ø50)	0.96	1.20	1.20	1.20	1.20	1.20
11		6537	PA 6133 (Ø80)	0.96	2.08	1.85	3.38	2.69
12	PA 6134 (80x40)		0.96	2.08	1.85	3.51	2.69	2.93
13	PA 6133 (Ø40)		0.96	2.01	1.85	2.01	2.01	2.01
14	PA 6133 (Ø50)		0.96	2.08	1.85	3.55	2.69	2.93
15	PP 6134 (80x40)		0.96	1.53	1.53	1.53	1.53	1.53
16	PP 6133 (Ø40)		0.96	1.53	1.53	1.53	1.53	1.53
17	PP 6133 (Ø50)		0.96	1.20	1.20	1.20	1.20	1.20
18	6081	6128 (70x70)	0.96	2.08	1.85	4.45	2.69	2.93
19		6129 (82x40)	0.96	2.08	1.85	4.45	2.69	2.93
20	6238	6126 (70x70)	0.96	2.08	1.85	4.45	2.69	2.93
21		6127 (82x40)	0.96	2.08	1.85	4.45	2.69	2.93
<sup>1)</sup> effective embedment depth (penetration length of threaded part) ≥ 18 mm <sup>2)</sup> effective embedment depth (penetration length of threaded part) ≥ 30 mm <sup>3)</sup> effective embedment depth (penetration length of threaded part) ≥ 22 mm <sup>4)</sup> effective embedment depth (penetration length of threaded part) ≥ 19 mm								
MAGE Flat Roof Fasteners						Annex 23		
Mean Values of Axial Load Resistance								