

European Technical Approval ETA-08/0098

English translation prepared by DIBt - Original version in German language

Handelsbezeichnung <i>Trade name</i>	SCHAEFER KALOTHERM System Klassik MW
Zulassungsinhaber <i>Holder of approval</i>	SCHAEFER KRUSEMARK GmbH & Co. KG Louise-Seher-Straße 6 65582 Diez DEUTSCHLAND
Zulassungsgegenstand und Verwendungszweck <i>Generic type and use of construction product</i>	Außenseitiges Wärmedämm-Verbundsystem mit Putzschicht zur Wärmedämmung von Gebäuden <i>External Thermal Insulation Composite System with rendering for the use as external insulation of building walls</i>
Geltungsdauer: <i>Validity:</i>	vom <i>from</i> bis <i>to</i> 4 April 2013 4 April 2018
Herstellwerk <i>Manufacturing plant</i>	SCHAEFER KRUSEMARK GmbH & Co. KG Louise-Seher-Straße 6 65582 Diez DEUTSCHLAND

Diese Zulassung umfasst
This Approval contains

18 Seiten einschließlich 1 Anhang
18 pages including 1 annex

Diese Zulassung ersetzt
This Approval replaces

ETA-08/0098 mit Geltungsdauer vom 02.06.2008 bis 02.06.2013
ETA-08/0098 with validity from 02.06.2008 to 02.06.2013

I LEGAL BASES AND GENERAL CONDITIONS

- 1 This European technical approval is issued by Deutsches Institut für Bautechnik in accordance with:
 - Council Directive 89/106/EEC of 21 December 1988 on the approximation of laws, regulations and administrative provisions of Member States relating to construction products¹, modified by Council Directive 93/68/EEC² and Regulation (EC) N° 1882/2003 of the European Parliament and of the Council³;
 - *Gesetz über das In-Verkehr-Bringen von und den freien Warenverkehr mit Bauprodukten zur Umsetzung der Richtlinie 89/106/EWG des Rates vom 21. Dezember 1988 zur Angleichung der Rechts- und Verwaltungsvorschriften der Mitgliedstaaten über Bauprodukte und anderer Rechtsakte der Europäischen Gemeinschaften (Bauproduktengesetz - BauPG) vom 28. April 1998⁴, as amended by Article 2 of the law of 8 November 2011⁵;*
 - Common Procedural Rules for Requesting, Preparing and the Granting of European technical approvals set out in the Annex to Commission Decision 94/23/EC⁶;
 - Guideline for European technical approval of "External Thermal Insulation Composite Systems with Rendering", ETAG 004, edition March 2000.
- 2 Deutsches Institut für Bautechnik is authorized to check whether the provisions of this European technical approval are met. Checking may take place in the manufacturing plant. Nevertheless, the responsibility for the conformity of the products to the European technical approval and for their fitness for the intended use remains with the holder of the European technical approval.
- 3 This European technical approval is not to be transferred to manufacturers or agents of manufacturers other than those indicated on page 1, or manufacturing plants other than those laid down in the context of this European technical approval.
- 4 This European technical approval may be withdrawn by Deutsches Institut für Bautechnik, in particular pursuant to information by the Commission according to Article 5 (1) of Council Directive 89/106/EEC.
- 5 Reproduction of this European technical approval including transmission by electronic means shall be in full. However, partial reproduction can be made with the written consent of Deutsches Institut für Bautechnik. In this case partial reproduction has to be designated as such. Texts and drawings of advertising brochures shall not contradict or misuse the European technical approval.
- 6 The European technical approval is issued by the approval body in its official language. This version corresponds fully to the version circulated within EOTA. Translations into other languages have to be designated as such.

¹ Official Journal of the European Communities L 40, 11 February 1989, p. 12
² Official Journal of the European Communities L 220, 30 August 1993, p. 1
³ Official Journal of the European Union L 284, 31 October 2003, p. 25
⁴ *Bundesgesetzblatt Teil I 1998*, p. 812
⁵ *Bundesgesetzblatt Teil I 2011*, p. 2178
⁶ Official Journal of the European Communities L 17, 20 January 1994, p. 34

II SPECIFIC CONDITIONS OF THE EUROPEAN TECHNICAL APPROVAL

1 Definition of products and intended use

The External Thermal Insulation Composite System "SCHAEFER KALOTHERM System Klassik MW" called ETICS in the following text, is designed and installed in accordance with the ETA-holder's design and installation instructions, deposited with the Deutsches Institut für Bautechnik (DIBt). The ETICS comprises the following components, which are factory-produced by the ETA-holder or a supplier. It's made up on site from these. The ETA-holder is ultimately responsible for the ETICS.

1.1 Definition of the construction product

	Components (see clause 2.3 for further description, characteristics and performances)	Coverage [kg/m ²]	Thickness [mm]
Insulation material with associated method of fixing	Bonded ETICS: <ul style="list-style-type: none"> • Insulation product factory-prefabricated mineral wool (MW) product to EN 13162:2008 <ul style="list-style-type: none"> - MW lamella • Adhesives <ul style="list-style-type: none"> - UNO FEIN 510 (cement based powder requiring addition of about 30 % of water) - MULTI 550 (cement based powder requiring addition of about 20 % of water) - MULTIPLUS 560 (cement based powder requiring addition of about 20 % of water) - MULTILIGHT PLUS 570 (cement based powder requiring addition of about 20 % of water) 	<p style="text-align: center;">–</p> <p style="text-align: center;">4.5 to 7.0 (prepared)</p> <p style="text-align: center;">6.0 to 7.5 (prepared)</p> <p style="text-align: center;">4.2 to 6.3 (prepared)</p>	<p style="text-align: center;">≤ 200</p> <p style="text-align: center;">–</p> <p style="text-align: center;">–</p> <p style="text-align: center;">–</p>
	Mechanically fixed ETICS with profiles and supplementary adhesive: <ul style="list-style-type: none"> • Insulation product factory-prefabricated mineral wool (MW) product to EN 13162:2008 <ul style="list-style-type: none"> - MW panel, $\sigma_{mt} \geq 14$ kPa • Supplementary adhesive (equal to bonded ETICS) • Profiles <ul style="list-style-type: none"> - "Alu-Halteleiste" and - "Alu-Verbindungsleiste" 	–	60 to 200

	Components (see clause 2.3 for further description, characteristics and performances)	Coverage [kg/m ²]	Thickness [mm]
Insulation material with associated method of fixing	<ul style="list-style-type: none"> • Anchors for profiles <ul style="list-style-type: none"> - ejothem SK U - WS 8 L - WS 8 N - ejothem SDK U - IsoFux ND-8Z - SDF-K plus, SDF-S - ejothem NK U • Anchors for insulation product if necessary (equal to mechanically fixed ETICS with anchors and supplementary adhesive, see below) 		
	<p>Mechanically fixed ETICS with anchors and supplementary adhesive:</p> <ul style="list-style-type: none"> • Insulation product factory-prefabricated mineral wool (MW) product to EN 13162:2008 <ul style="list-style-type: none"> - MW panel - MW lamella • Supplementary adhesive (equal to bonded ETICS) • Anchors for insulation product all anchors with ETA according to ETAG 014⁷ with characteristics defined in clause 2.3.2 	<p>–</p> <p>–</p>	<p>60 to 340</p> <p>60 to 200</p>
Base coat	<p>MULTI 550 MULTIPLUS 560 Identical with the equally named adhesives given above.</p>	<p>about 6.5 (prepared)</p>	<p>about 5.0</p>
Glass fibre mesh	<p>System-Armierungsgewebe Alkali- and slide-resistant glass fibre mesh with mass per unit area of about 200 g/m² and mesh size of about 6.0 mm x 6.0 mm.</p>	<p>–</p>	<p>–</p>
Key coat	<p>Quarzgrund Isoliergrund Ready to use pigmented acrylic-resin dispersion liquid For the compatibility with the finishing coats see below</p>	<p>0.15 to 0.20 0.10 to 0.20 [l/m²]</p>	<p>-</p> <p>-</p>
Finishing coat	<p>Application without key coat:</p> <ul style="list-style-type: none"> • Thick layered cement based powder requiring addition of about 20 to 27 % of water: KRATZPUTZ (particle size 2.5 to 5.0 mm) 	<p>14.0 to 20.0 (prepared)</p>	<p>7.0 to 10.0</p>

⁷

ETAG 014

Plastic anchors for fixing of external thermal insulation composite systems with rendering

	Components (see clause 2.3 for further description, characteristics and performances)	Coverage [kg/m ²]	Thickness [mm]
Finishing coat	To use with key coat "Quarzgrund" or "Isoliergrund" if applicable:* <ul style="list-style-type: none"> Thick layered cement based powder requiring addition of about 27 to 33 % of water: OPTIMAL <ul style="list-style-type: none"> - Struktur "Scheibenputz" - Struktur "Rillenputz" - Struktur "Strukturputz" 	3.0 to 5.0 (prepared)	1.5 to 4.0
	To use with key coat "Quarzgrund" if applicable:* <ul style="list-style-type: none"> Ready to use pastes – acrylic-resin binder SILIKONHARZPUTZ <ul style="list-style-type: none"> - Struktur "Rillenputz" (particle size 2 and 3 mm) - Struktur "Scheibenputz" (particle size 1.5 – 2 and 3 mm) <ul style="list-style-type: none"> Ready to use pastes – silicate/acrylic-resin binder: SILIKATPUTZ <ul style="list-style-type: none"> - Struktur "Rillenputz" (particle size 2 and 3 mm) - Struktur "Scheibenputz" (particle size 1.5 – 2 and 3 mm) 		3.0 to 4.5
Ancillary material	Description in accordance with clause 3.2.2.5 of ETAG 004 and decorative coatings compatible with the ETICS to be applied to the finishing coat. Remains the responsibility of the ETA-holder.		

* The instruction to the installer concerning the use of a key coat remains the responsibility of the ETA-holder.

1.2 Intended use

This ETICS is intended to be used as external insulation to the walls of buildings made of masonry (bricks, blocks, stones ...) or concrete (cast on site or as prefabricated panels) with and without rendering (Class A1 or A2 - s1,d0 according to EN 13501-1:2007). It shall be designed to give the wall to which it is applied satisfactory thermal insulation.

The ETICS is non load-bearing construction element. It does not contribute directly to the stability of the wall on which it is installed, but it can contribute to durability by providing enhanced protection from the effects of weathering.

The ETICS can be used on new or existing (retrofit) vertical walls.

The ETICS is not intended to ensure the air tightness of the building structure.

The choice of the method of fixing depends on the characteristics of the substrate, which could need preparation (see clause 7.2.1 of ETAG 004) and on the national instructions.

The provisions made in this European technical approval (ETA) based upon the assumed intended working life of the ETICS of at least 25 years, provided that the conditions laid down in clauses 4.2, 5.1 and 5.2 for the packaging, transport, storage, installation as well as appropriate use, maintenance and repair are met. The indications given on the working life cannot be interpreted as a guarantee given by the manufacturer or the Approval Body, but should only be regarded as a means to choosing the appropriate products in relation to the expected, economically reasonable working life of the works.

2 Characteristics of products and methods of verification

2.1 General

The assessment of the fitness for use of the ETICS for the intended use according to the Essential Requirements was carried out in compliance with ETAG 004, "Guideline for European Technical Approval of External Thermal Insulation Composite Systems with rendering", edition March 2000 (called ETAG 004 in this ETA).

Characteristics (of the components as well as of the ETICS), not mentioned in this ETA nor in the annex shall correspond to the respective values laid down in the technical documentation of this ETA.

2.2 Characteristics of the ETICS

2.2.1 Reaction to fire

Rendering system: Both base coats with finishing coat and compatible key coat indicated hereafter	Maximum declared organic content	Class according to EN 13501-1:2007
KRATZPUTZ	Base coat ≤ 3.7 % Finishing coat ≤ 0.6 %	A2 - s1,d0
OPTIMAL with key coat "Quarzgrund" or "Isoliergrund"		
SILIKONHARZPUTZ with key coat "Quarzgrund"	Base coat ≤ 3.7 % Finishing coat ≤ 8.8 %	
SILIKATPUTZ with key coat "Quarzgrund"	Base coat ≤ 3.7 % Finishing coat ≤ 4.5 %	

Mounting and fixing

(for all end use applications given in clause 1.2 of the ETA)

The assessment of reaction to fire is based on tests according to EN 13823:2002 – SBI-test and EN ISO 1716:2002 with a maximum insulation layer thickness of 160 mm, a density of about 140 kg/m³ as well as rendering systems with three different types of binder (cement based, silicate based and organic based) each with the highest organic content and the lowest amount of flame retardant and additives and with a thickness of 3 mm (finishing coat).

The manufacturer of the tested MW panels is Deutsche Rockwool Mineralwolle GmbH, 45966 Gladbeck.

Testing according to EN 1716:2002 was carried out with an adhesive with the highest organic content.

For the SBI-test the ETICS was mounted directly to a calcium silicate substrate (class A2 - s1,d0) according to EN 13238:2001 with a thickness of 11 mm.

The installation of the ETICS was carried out by the approval holder following his design and installation instructions using a single mesh all over the test specimen.

The tests specimens were prefabricated and did not include any joints.

For the SBI-test the lateral edges were covered with the rendering system.

Anchors were not included in the tested ETICS as they have no influence on the test result.

Note:

A European reference fire scenario for façades has not been laid down. In some Member States, the classification of ETICS according to EN 13501-1:2007 might not be sufficient for the use in facades. An additional assessment of ETICS according to national provisions (e.g. on the basis of a large scale test) might be necessary to comply with Member State regulations, until the existing European classification system has been completed.

2.2.2 Water absorption (capillarity test)

Base coat	Water absorption after 1 h < 1 kg/m ²	Water absorption after 24 h < 0.5 kg/m ²
MULTI 550	x	x
MULTIPLUS 560	x	x

Rendering system: Both base coats with finishing coat indicated hereafter	Water absorption after 24 h	
	< 0.5 kg/m ²	≥ 0.5 kg/m ²
KRATZPUTZ	x	
OPTIMAL	x	
SILIKONHARZPUTZ	x	
SILIKATPUTZ		x

2.2.3 Hygrothermal behaviour

Hygrothermal cycles tests have not been performed (see clause 2.2.10).

2.2.4 Freeze/thaw behaviour

As the water absorption of the base coats as well as rendering systems with finishing coats "KRATZPUTZ", "OPTIMAL" and "SILIKONHARZPUTZ" is less than 0.5 kg/m² after 24 hours the corresponding configurations of the ETICS are assessed as freeze/thaw resistant.

The ETICS with the finishing coat "SILIKATPUTZ" has been assessed as freeze/thaw resistant according to the simulated method.

2.2.5 Impact resistance

The verified resistance to hard body impact of the ETICS with both base coats and all finishing coats (thickness ≥ 3 mm) results in category II. The resistance to perforation has not to be verified, because of a total render thickness of not less than 6 mm.

The impact resistance of all other configurations of the ETICS is not determined (npd).

2.2.6 Water vapour permeability

Rendering system: Both base coats with finishing coat and compatible key coat indicated hereafter (evaluated without decorative coating)	Equivalent air thickness s_d
KRATZPUTZ	≤ 1.0 m (Test result obtained with $d = 8$ mm: 0.2 m)
OPTIMAL with key coat "Quarzgrund" or "Isoliergrund"	≤ 1.0 m (Test result obtained with $d = 3$ mm: 0.1 m)
SILIKONHARZPUTZ with key coat "Quarzgrund"	≤ 1.0 m (Test result obtained with particles size 3 mm: 0.3 m)
SILIKATPUTZ with key coat "Quarzgrund"	≤ 1.0 m (Test result obtained with particles size 3 mm: 0.1 m)

2.2.7 Emission of dangerous substances or radiation

The ETICS complies with the provisions of Guidance Paper H ("A harmonized approach related to dangerous substances under the construction product directives Revision August 2002").

In addition to the specific clauses relating to dangerous substances contained in this ETA, there may be other requirements applicable to the products falling within its scope (e.g. transposed European legislation and national laws, regulations and administrative provisions). In order to meet the provisions of the Construction Products Directive, these requirements need also to be complied with, when and where they apply.

2.2.8 Safety in use

2.2.8.1 Bond strengths

Bond strength between base coat and insulation product (MW lamella)

Base coat	Conditioning		
	Initial state	After hygrothermal cycles on the rig	After freeze/thaw test
MULTI 550	≥ 0.08 MPa	< 0.08 MPa ⁸ but failure in the insulation product	Test not required because freeze/thaw cycles not necessary
MULTIPLUS 560	≥ 0.08 MPa	< 0.08 MPa ⁸ but failure in the insulation product	

⁸ According to the EOTA GD 004 existing data was used after EOTA consensus has been reached that the deviations of the test methods use from the EOTA test methods are not relevant or the results are on the safe side.

Bond strength between adhesive and substrate resp. insulation product (MW lamella)

Adhesive	Substrate resp. insulation product	Conditioning		
		Initial state	2 d immersion in water + 2 h drying	2 d immersion in water + 7 d drying
UNO FEIN 510	Concrete	≥ 0.25 MPa	≥ 0.08 MPa	≥ 0.25 MPa
	MW lamella	≥ 0.08 MPa	≥ 0.03 MPa	≥ 0.08 MPa
MULTI 550	Concrete	≥ 0.25 MPa	≥ 0.08 MPa	≥ 0.25 MPa
	MW lamella	≥ 0.08 MPa	≥ 0.03 MPa	≥ 0.08 MPa
MULTIPLUS 560	Concrete	≥ 0.25 MPa	≥ 0.08 MPa	≥ 0.25 MPa
	MW lamella	≥ 0.08 MPa	≥ 0.03 MPa	≥ 0.08 MPa
MULTILIGHT PLUS 570	Concrete	≥ 0.25 MPa	≥ 0.08 MPa	≥ 0.25 MPa
	MW lamella	≥ 0.08 MPa	≥ 0.03 MPa	≥ 0.08 MPa

Bonded surface:

With a bonded surface of 50 % the formula given in clause 6.1.4.1.3 of ETAG 004 is fulfilled and the use as bonded ETICS is possible.

2.2.8.2 Fixing strength (displacement test)

Test not required because the ETICS fulfils the following criterion to clause 5.1.4.2 of ETAG 004:

- $E \cdot d < 50\,000 \text{ N/mm}$

(E: modulus of elasticity of the base coat – d: mean dried thickness of the base coat)

2.2.8.3 Wind load resistance

Safety in use of mechanically fixed ETICS using profiles

The following failure loads only apply to the listed combination (MW panel's characteristics)/ (way of fixing the ETICS) and the characteristics of the insulation product given in clause 2.3.1.

Failure loads – Table 1

Characteristics of the MW panels	Dimensions	625 mm x 800 mm
	Thickness	≥ 60 mm
	Tensile strength perpendicular to the faces	≥ 14 kPa
Failure loads [N/panel] (Static Foam Block Test)	Horizontal profiles with a vertical distance of 625 mm, fixed every 30 cm and vertical connection profiles No additional anchors in MW panel	Minimal: 1200 Average: 1250

Failure loads – Table 2

Characteristics of the MW panels	Dimensions	625 mm x 800 mm
	Thickness	≥ 60 mm
	Tensile strength perpendicular to the faces	≥ 14 kPa
Failure loads [N/panel] (Static Foam Block Test)	Horizontal profiles with a vertical distance of 625 mm, fixed every 30 cm and vertical connection profiles Two additional anchors per MW panel, plate diameter ≥ 60 mm, mounted on the MW panel surface	Minimal: 2200 Average: 2400

Safety in use of mechanically fixed ETICS using anchors

The following failure loads only apply to the listed combination (MW characteristics)/(anchor plate's characteristics) and the characteristics of the insulation product given in clause 2.3.1.

Failure loads – Table 3

Apply to all anchors listed in the Table in clause 1.1 mounted on the insulation panels surface			
Characteristics of the MW panels	Thickness		≥ 60 mm
	Tensile strength perpendicular to the faces		≥ 14 kPa
Plate diameter of anchor			≥ Ø 60 mm
Failure loads [N]	Anchors not placed at the panel joints (Static Foam Block Test)	R_{panel}	Minimal: 650 Average: 740
	Anchors placed at the panel joints (Static Foam Block Test)	R_{joint}	Minimal: 590 Average: 610
	Anchors not placed at the panel joints (Pull-through test, dry conditions)	R_{panel}	Minimal: 640 Average: 690
	Anchors not placed at the panel joints (Pull-through test, wet conditions) - series 2* - series 3*	R_{panel}	Minimal: 360 Average: 390 Minimal: 410 Average: 450
* According to ETAG 004 clause 5.2.4.1.2 test method (2)			

Failure loads – Table 4

Apply to all anchors listed in the Table in clause 1.1 mounted on the insulation panels surface				
Characteristics of the MW panels	Thickness		≥ 80 mm	
	Tensile strength perpendicular to the faces		≥ 5.0 kPa	
Plate diameter of anchor			≥ Ø 90 mm	≥ Ø 140 mm
Failure loads [N]	Anchors not placed at the panel joints (Static Foam Block Test)	R_{panel}	Minimal: 480 Average: 490	Minimal: 560 Average: 690
	Anchors placed at the panel joints (Static Foam Block Test)	R_{joint}	Minimal: 380 Average: 390	Minimal: 440 Average: 540
	Anchors not placed at the panel joints (Pull-through test, dry conditions)	R_{panel}	Minimal: 540 Average: 610	npd
	Anchors not placed at the panel joints (Pull-through test, wet conditions) - series 2*	R_{panel}	Minimal: 400 Average: 460	npd
* According to ETAG 004 clause 5.2.4.1.2 test method (2)				

Failure loads – Table 5

Apply to all anchors listed in the Table in clause 1.1 mounted on the insulation panels surface			
Characteristics of the MW lamella	Thickness		≥ 60 mm
	Tensile strength perpendicular to the faces		≥ 80 kPa
Plate diameter of anchor			≥ Ø 140 mm
Failure loads [N]	Anchors placed at the panel joints (Pull-through test, dry condition)	R _{joint}	Minimal: 620 Average: 660
	Anchors placed at the panel joints (Pull-through test, wet condition)	R _{joint}	Minimal: 510 Average: 570
	Anchors placed at the panel joints (Static Foam Block Test)	R _{joint}	Minimal: 710

The failure loads specified above apply to the following anchors with deep mounting but only on the following conditions of installation:

Anchor	Thickness of the MW panel [d]	Conditions of installation*
ejotherm STR U ejotherm STR U 2G (ETA-04/0023)	100 mm > d ≥ 80 mm	– Maximum installation depth of the anchor plate: 15 mm (≙ thickness of insulation cover) – Maximum depth of die: 5 mm
	≥ 100 mm	– Maximum installation depth of the anchor plate: 15 mm (≙ thickness of insulation cover) – Maximum depth of die: 20 mm
TERMOZ 8 SV (ETA-06/0180)	≥ 80 mm	– Maximum installation depth of the anchor plate: 15 mm (≙ thickness of insulation cover)

* According to the appropriate ETA of anchor

The wind load resistance R_d of the ETICS is calculated as follows:

$$R_d = \frac{R_{\text{panel}} \cdot n_{\text{panel}} + R_{\text{joint}} \cdot n_{\text{joint}}}{\gamma}$$

n_{panel}: number (per m²) of anchors not placed at the panel joints

n_{joint}: number (per m²) of anchors placed at the panel joint

γ: national safety factor

2.2.9 Thermal resistance

The nominal value of the additional thermal resistance R provided by the ETICS to the substrate wall is calculated in accordance with EN ISO 6946:2007 from the nominal value of the insulation product's thermal resistance R_D given accompanied to the CE marking and from the thermal resistance of the rendering system R_{render} which is about 0.02 (m²· K)/W.

$$R = R_D + R_{\text{render}}$$

The thermal bridges caused by mechanical fixing devices (anchors, profiles) increase the thermal transmittance U. This influence had to take into account according to EN ISO 6946:2007.

$$U_c = U + \Delta U \quad \text{corrected thermal transmittance}$$

$$\Delta U = \Delta U_{\text{anchor}} + \Delta U_{\text{profile}} \quad \text{correction term for mechanical fixing devices (anchors, profiles)}$$

$$\Delta U_{\text{anchor}} = \chi_p \cdot n \quad \text{correction term for anchors}$$

where: n	number of anchors per m ²
χ_p	local influence of thermal bridge caused by an anchor. The values listed below can be taken into account, if not specified in the anchor's technical approval
$\chi_p = 0.004 \text{ W/K}$	for anchors with a galvanized steel screw with the head covered by a plastic material
$\chi_p = 0.002 \text{ W/K}$	for anchors with a stainless steel screw with the head covered by plastic material, and for anchors with an air gap at the head of the screw
$\Delta U_{\text{profile}} = \Psi \cdot l$	correction term for profiles; $\Delta U_{\text{profile}}$ is determined in accordance with EN ISO 10211:2007
where: Ψ	length thermal transmittance value of the profile [W/(m·K)]
l	length of profile per m ² [m/m ²]

2.2.10 Aspects of durability and serviceability

2.2.10.1 Experience on site of the ETICS

An extensive experience on site has been assessed by the DIBt in Germany.

2.2.10.2 Bond strength after ageing

Rendering system: Both base coats with finishing coat indicated hereafter	OPTIMAL	≥ 0.08 MPa
	KRATZPUTZ	
	SILIKONHARZPUTZ	
	SILIKATPUTZ	

2.3 Characteristics of the components

Detailed information on the chemical composition and other identifying characteristics of the components, following Annex C of ETAG 004 have been deposited with the DIBt.

Further information can be observed from the product data sheets, which are part of the technical documentation for this ETA.

2.3.1 Thermal insulation product

Factory-prefabricated panels and lamella made of mineral wool (MW) to EN 13162:2008 with the following designation code and the other properties having the description in the Table below shall be used, provided that the manufacturer and the trade name of the MW are deposited with the DIBt.

MW – EN 13162 – T5 – DS(T+) – WS – WL(P) – MU1

Description and characteristics	MW panel	MW panel	MW lamella
Reaction to fire; EN 13501-1:2007	Class A1		
Gross heat of combustion [MJ/kg]; EN ISO 1716:2002	PCS ≤ 1.22		
Thermal resistance [(m ² ·K)/W]	Defined in the CE marking in reference to EN 13162:2008		
Tensile strength perpendicular to the faces [kPa]; EN 1607:1997 - in dry conditions*	$\sigma_{mt} \geq 14$	$\sigma_{mt} \geq 5$	$\sigma_{mt} \geq 80$
- in wet conditions** Average value - series 2 - series 3	≥ 33 % of average value in dry conditions ≥ 50 % of average value in dry conditions		

Description and characteristics	MW panel	MW panel	MW lamella
Compressive strength* [kPa]; EN 826:1996	$\sigma_m \geq 40$	$\sigma_m \geq 4$	$\sigma_m \geq 40$
Apparent density [kg/m ³]; EN 1602:1996	$120 \leq \rho_a \leq 140$	$100 \leq \rho_a \leq 140$	$80 \leq \rho_a \leq 140$
Shear strength* [kPa]; EN 12090:1997	$20 \leq f_{tk} \leq 100$	$6 \leq f_{tk} \leq 100$	$20 \leq f_{tk} \leq 100$
Shear modulus [MPa]; EN 12090:1997	$1.0 \leq G_m \leq 2.0$	$0.3 \leq G_m \leq 2.0$	$1.0 \leq G_m \leq 2.0$
* Minimal value of all single values ** According to ETAG 004 clause 5.2.4.1.2 test method (2)			

Thermal insulation materials (MW panel, $\sigma_{mt} \geq 14$ kPa) for mechanically fixed ETICS with profiles must circumferentially at the edges, 24 mm from the inner surface, get an approx. 3 mm wide and 13 to 18 mm deep groove cut-in at the factory.

2.3.2 Anchors

All anchors with ETA according to ETAG 014⁷ with characteristics having the description below shall be used in the mechanically fixed ETICS:

- plate diameter of anchor ≥ 60 mm resp. ≥ 90 mm or ≥ 140 mm
- plate stiffness ≥ 0.3 kN/mm
- load resistance of the anchor plate ≥ 1.0 kN

These characteristics and the characteristic tension resistance of the anchors shall be taken from the corresponding ETA.

The anchors listed in the Table in clause 1.1 with reference to the respective ETA shall be used in the mechanically fixed ETICS with profiles for fixing the horizontal profiles.

Trade name	ETA-number
ejothem SK U	ETA-02/0018
WS 8 L	ETA-02/0019
WS 8 N	ETA-03/0019
ejothem SDK U	ETA-04/0023
IsoFux ND-8Z	ETA-04/0032
SDF-K plus, SDF-S plus	ETA-04/0064
ejothem NK U	ETA-05/0009

2.3.3 Profiles

Aluminium (Al) profiles, EN AW-6060 T66 to EN 755-2:2008 with the measurements according to Annex 1 are to be used in the mechanically fixed ETICS with profiles.

The Pull-through resistance of fixings from profiles is ≥ 500 N.

2.3.4 Render (base coat)

No performance determined for the width of cracks.

2.3.5 Reinforcement (glass fibre mesh)

Characteristics (alkali resistance): Pass

	"System-Armierungsgewebe"	
	Warp	Weft
Residual strength after ageing [N/mm]	≥ 20	≥ 20
Relative residual resistance after ageing in % of the strength in the as-delivered state	≥ 50	≥ 50

3 Evaluation and attestation of conformity and CE-marking

3.1 System of attestation of conformity

According to the decision 97/556/EC of the European Commission⁹ amended by 2001/596/EC¹⁰ system 1 or 2+ of the attestation of conformity applies depending on reaction to fire.

Considering Class A2 for reaction to fire of the ETICS, the systems of attestation of conformity are system 1 regarding reaction to fire characteristic and system 2+ regarding other characteristics than reaction to fire.

These systems of attestation of conformity are defined as follows:

System 1: Certification of the conformity of the product by a notified certification body on the basis of:

(a) Tasks for the manufacturer:

- (1) factory production control;
- (2) further testing of samples taken at the factory by the manufacturer in accordance with a prescribed test plan;

(b) Tasks for the notified body:

- (3) initial type-testing of the product;
- (4) initial inspection of factory and of factory production control;
- (5) continuous surveillance, assessment and approval of factory production control.

System 2+: Declaration of conformity of the product by the manufacturer on the basis of:

(a) Tasks for the manufacturer:

- (1) initial type-testing of the product;
- (2) factory production control;
- (3) testing of samples taken at the factory in accordance with a prescribed test plan.

(b) Tasks for the notified body:

- (4) certification of factory production control on the basis of:
 - initial inspection of factory and of factory production control;
 - continuous surveillance, assessment and approval of factory production control.

⁹
¹⁰

Official Journal of the European Communities/Union L229/14 of 20.08.1997
Official Journal of the European Communities/Union L 209/33 of 2.8.2001

3.2 Responsibilities

3.2.1 Tasks for the manufacturer

3.2.1.1 Factory production control

The manufacturer shall exercise permanent internal control of production. All the elements, requirements and provisions adopted by the manufacturer shall be documented in a systematic manner in the form of written policies and procedures, including records of results performed. This production control system shall insure that the ETICS and the components are in conformity with this ETA.

The manufacturer shall only use raw materials stated in the technical documentation of this ETA. The incoming raw materials are subjected to verifications by the manufacturer before acceptance.

The factory production control shall be in accordance with the "Control plan"¹¹ which is part of the technical documentation of this ETA. The "Control plan"¹¹ has been agreed between the manufacturer and the DIBt and is laid down in the context of the factory production control system operated by the manufacturer and deposited with the DIBt.

The results of factory production control shall be recorded and evaluated in accordance with the provisions of the "Control plan"¹¹. The records include at least the following information:

- designation of the product, the basic materials and components;
- type of control or testing;
- date of manufacture of the product and date of testing of the product or basic materials or components;
- result of control and testing and, if appropriate, comparison with requirements;
- signature of person responsible for factory production control.

The records shall be presented to the notified body involved in continuous surveillance. On request they shall be presented to the DIBt.

3.2.1.2 Other tasks for the manufacturer

For initial type-testing of the ETICS and the components regarding other characteristics than reaction to fire the results of the tests performed as part of the assessment for the ETA shall be used unless there are changes in the production line or plant. In such cases the necessary initial type-testing has to be agreed with the DIBt.

The manufacturer shall, on the basis of a contract, involve a body which is notified for the tasks referred to in clause 3.1 in the field of ETICS in order to undertake the actions laid down in clause 3.2.2. For this purpose, the "Control plan"¹¹ referred to in clauses 3.2.1.1 and 3.2.2 shall be handed over by the manufacturer to the notified bodies involved.

The manufacturer shall make a declaration of conformity, stating that the ETICS is in conformity with the provisions of ETA-08/0098 issued on 4 April 2013.

3.2.2 Tasks for the notified bodies

The notified body shall perform the

- initial type-testing of the ETICS and the components regarding reaction to fire characteristic,
- initial inspection of factory and of factory production control,
- continuous surveillance, assessment and approval of factory production control,

¹¹ The "Control plan" is a confidential part of the European technical approval and only handed over to the notified body involved in the procedure of attestation of conformity. See section 3.2.2.

in accordance with the provisions laid down in the "Control plan"¹¹.

The notified body shall retain the essential points of its actions referred to above and state the results obtained and conclusions drawn in a written report.

The notified certification body involved by the manufacturer shall issue an EC certificate of conformity of the ETICS which includes the certification of factory production control stating the conformity with the provisions of this ETA.

In cases where the provisions of the ETA and its "Control plan"¹¹ are no longer fulfilled the notified certification body shall withdraw the certificate of conformity and inform the DIBt without delay.

3.3 Marking

3.3.1 CE marking

The CE marking shall be affixed on the accompanying commercial document. The letters "CE" shall be followed by the identification number of the notified certification body and be accompanied by the following additional information:

- the name and address of the ETA-holder (legal entity responsible for the manufacture),
- the last two digits of the year in which the CE marking was affixed,
- the number of the EC certificate of conformity for the ETICS,
- the number of the ETA,
- the number of the ETAG,
- the ETICS trade name.

3.3.2 Additional marking

The respective trade name of the individual components of the ETICS shall be given on the packaging.

In addition to the trade name the following information shall be given in the accompanying commercial document and/or on the packaging of the thermal insulation product:

- minimum value of the tensile strength perpendicular to the faces of the insulation product,
- shear modulus of the insulation product.

4 Assumptions under which the fitness of the product for the intended use was favourably assessed

4.1 Manufacturing

The composition and manufacturing process used for the components of the ETICS shall comply with those on which the approval tests were based. Composition and manufacturing process are deposited at the DIBt.

The ETA is issued for the ETICS on the basis of agreed data/information, deposited with the DIBt, which identifies the ETICS that has been assessed and judged. Changes to the ETICS or the components or their production process, which could result in this deposited data/information being incorrect, should be notified to the DIBt before the changes are introduced. DIBt will decide whether or not such changes affect the approval and consequently the validity of the CE marking on the basis of the approval and if so whether further assessment or alterations to the approval shall be necessary.

4.2 Installation, design and execution

4.2.1 General

The wall on which the ETICS is applied shall be sufficiently stable and airtight. Its stiffness shall be large enough to ensure that the ETICS is not subjected to deformations, which could lead to damage.

The requirements given in ETAG 004, chapter 7, have to be considered.

4.2.2 Installation

The ETICS is installed on site. The approval holder is obliged to instruct all those entrusted with the design and execution of the ETICS about the specific conditions of this ETA and all other details necessary for perfect execution.

Only the components whose trade name is given in clause 1.1 and which have the characteristics according to clause 2.3 may be used for the ETICS.

4.2.3 Design

4.2.3.1 Requirements for the substrate

As to the requirements for the substrate and its preparation, ETAG 004, clause 7.2.1 applies.

The substrate for mechanically fixed systems should have a sufficient resistance for the use of anchors according to clause 2.3.2. The conditions of the ETA for the anchor concerned apply.

4.2.3.2 Resistance to wind load

Judging of sufficient resistance to wind load should be on the basis of the resistance of the fixings according to clause 2.2.8.3 and of the characteristic tension resistance of the used anchor according to clause 2.3.2. Taking into account the national safety factors the design values of resistance are determined. The smaller one of the design resistances of the ETICS (R_d) and of the anchor (N_{Rd}) is decisive.

The determined design wind load suction S_d (taking into account the national safety factors) is compared with the design resistance.

4.2.4 Execution

The manufacturer's design and installation instructions, which are part of the technical documentation for this ETA, shall be observed with respect to the installation of the ETICS and drying times of rendering products.

5 Indications to the manufacturer

5.1 Packaging, transport and storage

Packaging of the components has to be such that they are protected against moisture during transport and storage, unless other measures are foreseen by the manufacturer for this purpose.

The components are to be protected against damage.

5.2 Use, maintenance, repair

To the indications on use, maintenance and repair ETAG 004, clause 7.3 applies.

Uwe Bender
Head of Department

beglaubigt:
Wachner

Horizontal profile – "Alu-Halteleiste" (dimensions in millimetres)

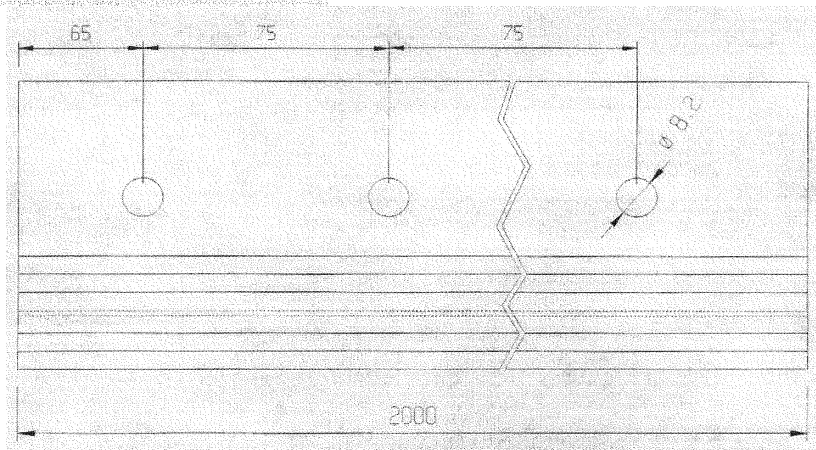
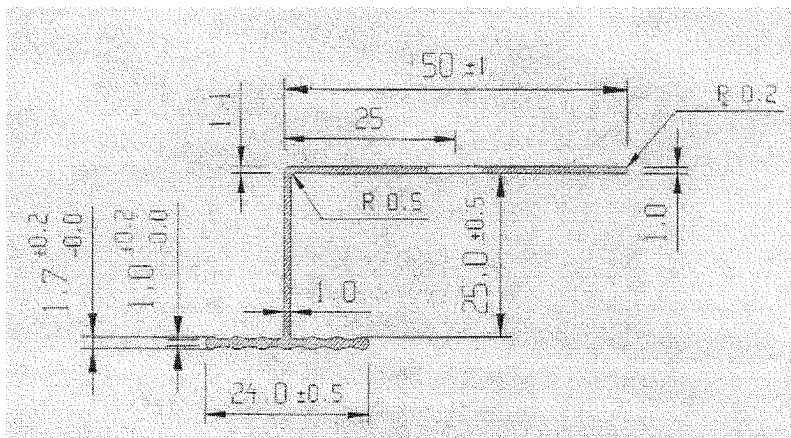

Vertical connection profile – "Alu-Verbindungsleiste" (dimensions in millimetres)

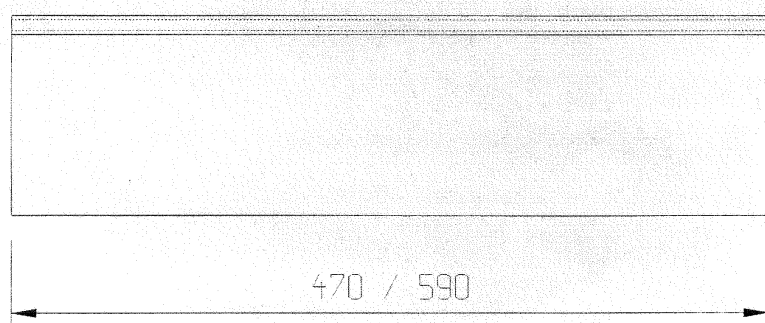
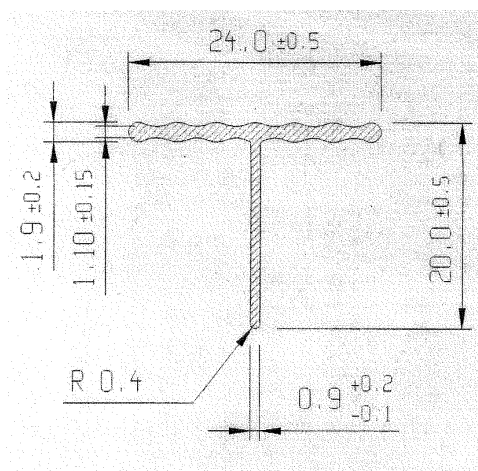

Electronic copy of the ETA by DIBt: ETA-08/0098

ETICS SCHAEFER KALOTHERM System Klassik MW

Horizontal and vertical Al profiles

Annex 1