



## European Technical Approval ETA-08/0278

English translation prepared by DIBt - Original version in German language

Handelsbezeichnung <i>Trade name</i>	KEIL Fassadendübel KT 10 und KT 14 <i>KEIL Facade Anchor KT 10 and KT 14</i>
Zulassungsinhaber <i>Holder of approval</i>	KEIL Befestigungstechnik GmbH Im Auel 42 51766 Engelskirchen DEUTSCHLAND
Zulassungsgegenstand und Verwendungszweck <i>Generic type and use of construction product</i>	Kunststoffdübel als Mehrfachbefestigung von nichttragenden Systemen zur Verankerung im Beton und Mauerwerk <i>Plastic anchor for multiple use in concrete and masonry for non- structural applications</i>
Geltungsdauer: <i>Validity:</i>	vom <i>from</i> bis <i>to</i> 13 February 2013 18 October 2017
Herstellwerk <i>Manufacturing plant</i>	KEIL Werk 1

Diese Zulassung umfasst  
*This Approval contains*

20 Seiten einschließlich 9 Anhänge  
*20 pages including 9 annexes*

Diese Zulassung ersetzt  
*This Approval replaces*

ETA-08/0278 mit Geltungsdauer vom 06.01.2011 bis 01.12.2013  
*ETA-08/0278 with validity from 06.01.2011 to 01.12.2013*

## I LEGAL BASES AND GENERAL CONDITIONS

- 1 This European technical approval is issued by Deutsches Institut für Bautechnik in accordance with:
  - Council Directive 89/106/EEC of 21 December 1988 on the approximation of laws, regulations and administrative provisions of Member States relating to construction products<sup>1</sup>, modified by Council Directive 93/68/EEC<sup>2</sup> and Regulation (EC) N° 1882/2003 of the European Parliament and of the Council<sup>3</sup>;
  - *Gesetz über das In-Verkehr-Bringen von und den freien Warenverkehr mit Bauprodukten zur Umsetzung der Richtlinie 89/106/EWG des Rates vom 21. Dezember 1988 zur Angleichung der Rechts- und Verwaltungsvorschriften der Mitgliedstaaten über Bauprodukte und anderer Rechtsakte der Europäischen Gemeinschaften (Bauproduktengesetz - BauPG) vom 28. April 1998<sup>4</sup>, as amended by Article 2 of the law of 8 November 2011<sup>5</sup>;*
  - Common Procedural Rules for Requesting, Preparing and the Granting of European technical approvals set out in the Annex to Commission Decision 94/23/EC<sup>6</sup>;
  - Guideline for European technical approval of "Plastic Anchors for Multiple Use in Concrete and Masonry for Non-structural Applications - Part 1: General", ETAG 020-01.
- 2 Deutsches Institut für Bautechnik is authorized to check whether the provisions of this European technical approval are met. Checking may take place in the manufacturing plant. Nevertheless, the responsibility for the conformity of the products to the European technical approval and for their fitness for the intended use remains with the holder of the European technical approval.
- 3 This European technical approval is not to be transferred to manufacturers or agents of manufacturers other than those indicated on page 1, or manufacturing plants other than those indicated on page 1 of this European technical approval.
- 4 This European technical approval may be withdrawn by Deutsches Institut für Bautechnik, in particular pursuant to information by the Commission according to Article 5(1) of Council Directive 89/106/EEC.
- 5 Reproduction of this European technical approval including transmission by electronic means shall be in full. However, partial reproduction can be made with the written consent of Deutsches Institut für Bautechnik. In this case partial reproduction has to be designated as such. Texts and drawings of advertising brochures shall not contradict or misuse the European technical approval.
- 6 The European technical approval is issued by the approval body in its official language. This version corresponds fully to the version circulated within EOTA. Translations into other languages have to be designated as such.

<sup>1</sup> Official Journal of the European Communities L 40, 11 February 1989, p. 12  
<sup>2</sup> Official Journal of the European Communities L 220, 30 August 1993, p. 1  
<sup>3</sup> Official Journal of the European Union L 284, 31 October 2003, p. 25  
<sup>4</sup> *Bundesgesetzblatt Teil I 1998*, p. 812  
<sup>5</sup> *Bundesgesetzblatt Teil I 2011*, p. 2178  
<sup>6</sup> Official Journal of the European Communities L 17, 20 January 1994, p. 34

## II SPECIFIC CONDITIONS OF THE EUROPEAN TECHNICAL APPROVAL

### 1 Definition of product and intended use

#### 1.1 Definition of the construction product

The KEIL Facade Anchor in the range of KT 10 and KT 14 is a plastic anchor consisting of a plastic sleeve made of polyamide and an accompanying specific screw of galvanised steel or stainless steel.

The plastic sleeve is expanded by screwing in the specific screw which presses the sleeve against the wall of the drilled hole.

The installed anchor is shown in Annex 1.

#### 1.2 Intended use

The anchor is intended to be used for anchorages for which requirements for safety in use in the sense of the Essential Requirement 4 of Council Directive 89/106/EEC shall be fulfilled and failure of the fixture represents an immediate risk to human life.

The anchor is to be used only for multiple fixing for non-structural applications in concrete and masonry. The base material shall consist of reinforced or unreinforced normal weight concrete of strength class C12/15 at minimum according to EN 206-1:2000-12 and of masonry walls according to Annex 6. The anchor may be used in cracked and non-cracked concrete. The mortar strength class of the masonry has to be M2,5 according to EN 998-2:2003 at minimum.

The anchor type KT 10 may also be used in masonry walls made of non-cracked autoclaved aerated concrete (AAC blocks) according to Annex 9.

The anchor may also be used in concrete with requirements related to resistance to fire according section 4.2.2.

The specific screw made of galvanised steel may only be used in structures subject to dry internal conditions.

The specific screw made of stainless steel may be used in structures subject to dry internal conditions and also in structures subject to external atmospheric exposure (including industrial and marine environment), or exposure in permanently damp internal conditions, if no particular aggressive conditions exist. Such particular aggressive conditions are e. g. permanent, alternating immersion in seawater or the splash zone of seawater, chloride atmosphere of indoor swimming pools or atmosphere with extreme chemical pollution (e. g. in desulphurization plants or road tunnels where de-icing materials are used).

The specific screw made of galvanised steel may also be used in structures subject to external atmospheric exposure, if the area of the head of the screw is protected against moisture and driving rain after mounting of the fixing unit in this way, that intrusion of moisture into the anchor shaft is prevented. Therefore there shall be an external cladding or a ventilated rainscreen mounted in front of the head of the screw and the head of the screw itself shall be coated with a soft plastic, permanently elastic bitumen-oil-combination coating (e. g. undercoating or body cavity protection for cars).

The anchor may be used in the following temperature range:

Temperature range a):	-40 °C to +40 °C	(max. long term temperature +24 °C and max. short term temperature +40 °C)
Temperature range b):	-40 °C to +80 °C	(max. long term temperature +50 °C and max. short term temperature +80 °C)

The provisions made in this European technical approval are based on an assumed working life of the anchor of 50 years. The indications given on the working life cannot be interpreted as a guarantee given by the producer, but are to be regarded only as a means for choosing the right products in relation to the expected economically reasonable working life of the works.

## 2 Characteristics of the product and methods of verification

### 2.1 Characteristics of the product

The anchor corresponds to the drawings and information given in Annex 2 and 3. The characteristic material values, dimensions and tolerances of the anchor not given in these Annexes shall correspond to the respective values laid down in the technical documentation<sup>7</sup> of this European technical approval.

The characteristic values for the design of the anchorages are given in Annex 3 to 11.

Each anchor is to be marked with the identifying mark, the type, the diameter, the length and shape of the anchor sleeve according to Annex 2.

The minimum embedment depth shall be marked.

The anchor shall only be packaged and supplied as a complete unit.

In addition to the specific clauses relating to dangerous substances contained in this European technical approval, there may be other requirements applicable to the products falling within its scope (e. g. transposed European legislation and national laws, regulations and administrative provisions). In order to meet the provisions of the Construction Products Directive, these requirements need also to be complied with, when and where they apply.

### 2.2 Methods of verification

The assessment of the fitness of the anchor for the intended use in relation to the requirements for safety in use in the sense of the Essential Requirement 4 has been made in compliance with the Guideline for European technical approval of "Plastic Anchors for Multiple Use in Concrete and Masonry for Non-structural Applications", ETAG 020,

- Part 1: "General",
- Part 2: "Plastic Anchors for Use in Normal Weight Concrete",
- Part 3: "Plastic Anchors for Use in Solid Masonry Materials",
- Part 4: "Plastic Anchors for Use in Hollow or Perforated Masonry" and
- Part 5: "Plastic Anchors for Use in Autoclaved Aerated Concrete (AAC)"

based on the use categories a, b, c and d (KT 10) respectively the use categories a and b (KT 14).

<sup>7</sup>

The technical documentation of this European technical approval is deposited at the Deutsches Institut für Bautechnik and, as far as relevant for the tasks of the approved bodies involved in the attestation of conformity procedure, is handed over to the approved bodies.

### 3 Evaluation and attestation of conformity and CE marking

#### 3.1 System of attestation of conformity

According to the decision 97/463/EG of the European Commission<sup>8</sup> the system 2(ii) (referred to as system 2+) of attestation of conformity applies.

This system of attestation of conformity is defined as follows.

System 2+: Declaration of conformity of the product by the manufacturer on the basis of:

- (a) Tasks for the manufacturer:
  - (1) initial type-testing of the product;
  - (2) factory production control;
  - (3) testing of samples taken at the factory in accordance with a prescribed test plan.
- (b) Tasks for the approved body:
  - (4) certification of factory production control on the basis of:
    - initial inspection of factory and of factory production control;
    - continuous surveillance, assessment and approval of factory production control.

#### 3.2 Responsibilities

##### 3.2.1 Tasks of the manufacturer

###### 3.2.1.1 Factory production control

The manufacturer shall exercise permanent internal control of production. All the elements, requirements and provisions adopted by the manufacturer shall be documented in a systematic manner in the form of written policies and procedures, including records of results performed. This production control system shall insure that the product is in conformity with this European technical approval.

The manufacturer may only use raw materials stated in the technical documentation of this European technical approval.

The factory production control shall be in accordance with the control plan which is part of the technical documentation of this European technical approval. The control plan is laid down in the context of the factory production control system operated by the manufacturer and deposited at Deutsches Institut für Bautechnik.<sup>9</sup>

The results of factory production control shall be recorded and evaluated in accordance with the provisions of the control plan.

###### 3.2.1.2 Other tasks of manufacturer

The manufacturer shall, on the basis of a contract, involve a body which is approved for the tasks referred to in section 3.1 in the field of anchors in order to undertake the actions laid down in section 3.2.2. For this purpose, the control plan referred to in sections 3.2.1.1 and 3.2.2 shall be handed over by the manufacturer to the approved body involved.

The manufacturer shall make a declaration of conformity, stating that the construction product is in conformity with the provisions of this European technical approval.

<sup>8</sup> Official Journal of the European Communities L 198 of 25.07.1997.

<sup>9</sup> The control plan is a confidential part of the documentation of the European technical approval, but not published together with the ETA and only handed over to the approved body involved in the procedure of attestation of conformity. See section 3.2.2.

### 3.2.2 Tasks of approved bodies

The approved body shall perform the

- initial inspection of factory and of factory production control,
- continuous surveillance, assessment and approval of factory production control in accordance with the provisions laid down in the control plan.

The approved body shall retain the essential points of its actions referred to above and state the results obtained and conclusions drawn in a written report.

The approved certification body involved by the manufacturer shall issue an EC certificate of conformity of the factory production control stating the conformity with the factory production control of this European technical approval.

In cases where the provisions of the European technical approval and its control plan are no longer fulfilled the certification body shall withdraw the certificate of conformity and inform Deutsches Institut für Bautechnik without delay.

### 3.3 CE marking

The CE marking shall be affixed on each packaging of the anchor. The letters "CE" shall be followed by the identification number of the approved certification body, where relevant, and be accompanied by the following additional information:

- the name and address of the producer (legal entity responsible for the manufacturer),
- the last two digits of the year in which the CE marking was affixed,
- the number of the EC certificate for the factory production control,
- the number of the European technical approval,
- the number of the guideline for European technical approval,
- use category a, b, c and d (KT 10) respectively use category a und b (KT 14).

## 4 Assumptions under which the fitness of the product for the intended use was favourably assessed

### 4.1 Manufacturing

The European technical approval is issued for the product on the basis of agreed data/information, deposited with Deutsches Institut für Bautechnik, which identifies the product that has been assessed and judged. Changes to the product or production process, which could result in this deposited data/information being incorrect, should be notified to Deutsches Institut für Bautechnik before the changes are introduced. Deutsches Institut für Bautechnik will decide whether or not such changes affect the ETA and consequently the validity of the CE marking on the basis of the ETA and if so whether further assessment or alterations to the ETA shall be necessary.

## 4.2 Design of anchorages

### 4.2.1 General

Fitness for the intended use of the anchor is given under the following conditions:

- The design of anchorages is carried out in compliance with ETAG 020, Guideline for European technical approval of "Plastic Anchors for Multiple Use in Concrete and Masonry for Non-structural Applications", Annex C under the responsibility of an engineer experienced in anchorages.
- Verifiable calculation notes and drawings shall be prepared taking account of the loads to be anchored, the nature and strength of the base materials and the dimensions of the anchorage members as well as of the relevant tolerances.
- The anchor is to be used only for multiple fixing for non-structural applications.

Therefore the design of the fixture may specify the number  $n_1$  of fixing points to fasten the fixture and the number  $n_2$  of anchors per fixing point. Furthermore by specifying the design value of actions  $N_{Sd}$  on a fixing point to a value  $\leq n_3$  (kN) up to which the strength and stiffness of the fixture are fulfilled and the load transfer in the case of excessive slip or failure of one anchor need not to be taken into account in the design of the fixture.

The following default values for  $n_1$ ,  $n_2$  and  $n_3$  may be taken:

$$\begin{array}{l} n_1 \geq 4; \quad n_2 \geq 1 \quad \text{and} \quad n_3 \leq 4,5 \text{ kN} \quad \text{or} \\ n_1 \geq 3; \quad n_2 \geq 1 \quad \text{and} \quad n_3 \leq 3,0 \text{ kN.} \end{array}$$

Shear loads acting on an anchor may be assumed to act without lever arm if both of the following conditions are fulfilled:

- The fixture shall be made of metal and in the area of the anchorage be fixed directly to the base material either without an intermediate layer or with a levelling layer of mortar with a thickness  $\leq 3$  mm.
- The fixture shall be in contact with the anchor over its entire thickness. (Therefore the diameter of clearance hole in the fixture  $d_f$  has to be equal or smaller than the values given in Annex 3, Table 3.)

If these two conditions are not fulfilled the lever arm is calculated according to ETAG 020, Annex C. The characteristic bending moment is given in Annex 3, Table 4.

### 4.2.2 Resistance in concrete (use category "a")

The characteristic values of resistance of the anchor for use in concrete are given in Annex 3, Table 4 and Annex 4, Table 5 and 6. The design method is valid for cracked and non-cracked concrete.

According to the Technical Report TR 020 "Evaluation of anchorages in concrete concerning resistance to fire" it can be assumed that for fastening of facade systems the load bearing behaviour of the KTS Facade Anchor KT 10 has a sufficient resistance to fire at least 90 minutes (R90) if the admissible load  $[F_{Rk} / (\gamma_M \cdot \gamma_F)]$  is  $\leq 0,8$  kN (no permanent centric tension load).

### 4.2.3 Resistance in solid masonry (use category "b")

The characteristic values of resistance of the anchor for use in solid masonry are given in Annex 3, Table 4 and Annex 6, Table 9.

The characteristic resistances for use in solid masonry given in Annex 6 are only valid for the base material and the bricks according this table or larger brick sizes and larger compressive strength of the masonry unit. These values are independent of the load direction (tension, shear or combined tension and shear) and the mode of failure.



If smaller brick sizes are present on the construction site or if the mortar strength is smaller than the required value, the characteristic resistance of the anchor may be determined by job site tests according to 4.4.

**4.2.4 Resistance in hollow or perforated masonry (use category "c")**

The characteristic values of resistance of the anchor for use in hollow or perforated masonry are given in Annex 3, Table 4 and Annex 6, Table 9.

The characteristic resistances for use in hollow or perforated masonry given in Annex 6 are only valid for the bricks and blocks according this table regarding base material, size of the units, compressive strength and configuration of the voids. These values are independent of the load direction (tension, shear or combined tension and shear) and the mode of failure and are valid for  $h_{nom} = 70$  mm only.

The influence of larger embedment depths ( $h_{nom} > 70$  mm) and/or different bricks and blocks (according Annex 6 regarding base material, size of the units, compressive strength and configuration of the voids) has to be detected by job site tests according to 4.4.

**4.2.5 Resistance in non-cracked autoclaved aerated concrete (AAC blocks, use category "d")**

The characteristic values of resistance of the anchor type KT 10 for use in non-cracked autoclaved aerated concrete (AAC blocks) are given in Annex 3, Table 4 and Annex 9, Table 14.

The values given in Annex 9, Table 14 are independent of the load direction (tension, shear or combined tension and shear) and the mode of failure.

The anchor shall not be installed and used in water saturated aerated concrete.

**4.2.6 Specific conditions for the design method in solid and hollow or perforated masonry and AAC blocks**

The mortar strength class of the masonry has to be M2,5 according to EN 998-2:2010 at minimum.

The characteristic resistance  $F_{Rk}$  for a single plastic anchor may also be taken for a group of two or four plastic anchors with a spacing equal or larger than the minimum spacing  $s_{min}$ .

The distance between single plastic anchors or a group of anchors should be  $a \geq 250$  mm.

If the vertical joints of the wall are designed not to be filled with mortar then the design resistance  $N_{Rd}$  has to be limited to 2,0 kN to ensure that a pull-out of one brick out of the wall will be prevented. This limitation can be omitted if interlocking units are used for the wall or when the joints are designed to be filled with mortar.

If the joints of the masonry are not visible the characteristic resistance  $F_{Rk}$  has to be reduced with the factor  $\alpha_j = 0,5$ .

If the joints of the masonry are visible (e. g. unplastered wall) following has to be taken into account:

- The characteristic resistance  $F_{Rk}$  may be used only, if the wall is designed such that the joints are to be filled with mortar.
- If the wall is designed such that the joints are not to be filled with mortar then the characteristic resistance  $F_{Rk}$  may be used only, if the minimum edge distance  $c_{min}$  to the vertical joints is observed. If this minimum edge distance  $c_{min}$  can not be observed then the characteristic resistance  $F_{Rk}$  has to be reduced with the factor  $\alpha_j = 0,5$ .



#### 4.2.7 Characteristic values, spacing and dimensions of anchorage member

The minimum spacing and dimensions of anchorage member according to Annex 5, Table 8 (concrete), Annex 8, Table 12 and 13 (masonry) and Annex 9, Table 16 (AAC) shall be observed depending on the base material.

#### 4.2.8 Displacement behaviour

The displacements under tension and shear loading are given in Annex 5, Table 7 (concrete), Annex 7, Table 10 (masonry) and Annex 9, Table 15 (AAC).

#### 4.3 Installation of anchor

The fitness for use of the anchor can only be assumed if the following conditions of installation are met:

- Anchor installation carried out by appropriately qualified personnel under the supervision of the person responsible for technical matters on site.
- Use of the anchor only as supplied by the manufacturer without exchanging any component of the anchor.
- Anchor installation in accordance with the manufacturer's specifications and drawings using the tools indicated in this European technical approval:
- Checks before placing the anchor, to ensure that the characteristic values of the base material in which the anchor is to be placed, is identical with the values, which the characteristic loads apply for.
- Observation of the drill method according Annex 6 and 9 (Drill holes in hollow or perforated masonry or autoclaved aerated concrete may only be drilled using the rotary drill. Other drilling methods may also be used if job-site tests according to 4.4 evaluate the influence of hammer or impact drilling.)
- Placing drill holes without damaging the reinforcement.
- The anchor shall not be installed and used in water saturated aerated concrete (AAC).
- Holes to be cleaned of drilling dust.
- In case of aborted hole: New drilling at a minimum distance away of twice the depth of the aborted hole or smaller distance if the aborted drill hole is filled with high strength mortar.
- The plastic sleeve is inserted through the fixture by slight hammer blows and the special screw is screwed in until the head of the screw touches the sleeve. The anchor is correct mounted, if there is no turn-through of the plastic sleeve in the drill hole and if slightly move on turning of the screw is impossible after the complete turn-in of the screw.
- Temperature during installation of the anchor  $\geq -20$  °C (plastic sleeve and base material).

#### 4.4 Job site tests according to ETAG 020, Annex B

##### 4.4.1 General

In the absence of national requirements the characteristic resistance of the plastic anchor may be determined by job site tests, if the plastic anchor has already characteristic values given in Annex 6 and 9 for the same base material as it is present on the construction works.

Furthermore job site tests for use in (different) solid masonry are possible only if the plastic anchor has already characteristic values given in Annex 6 and 9 for use in solid masonry.

Job site tests for use in (different) hollow or perforated masonry are possible only if the plastic anchor has already characteristic values given in Annex 6 for use in hollow or perforated masonry or in Annex 9 for use in autoclaved aerated concrete.

Job site tests are also possible, if another drill method is been used as it is given in Annex 6 and 9.

The characteristic resistance to be applied to a plastic anchor should be determined by means of at least 15 pull-out tests carried out on the construction work with a centric tension load acting on the plastic anchor. These tests may also be performed in a laboratory under equivalent conditions as used on construction work.

Execution and evaluation of the tests as well as issue of the test report and determination of the characteristic resistance should be supervised by the person responsible for execution of works on site and be carried out by a competent person.

Number and position of the plastic anchors to be tested should be adapted to the relevant special conditions of the construction work in question and, for example, in the case of blind and larger areas be increased such that a reliable information about the characteristic resistance of the plastic anchor embedded in the base material in question can be derived. The tests should take account of the unfavourable conditions of practical execution.

#### 4.4.2 Assembly

The plastic anchor to be tested shall be installed (e.g. preparation of drill hole, drilling tool to be used, drill bit, type of drilling hammer or rotation, thickness of fixture) and as far as spacing and edge distances are concerned be distributed in the same way as foreseen for the intended use.

Depending on the drilling tool hard metal hammer drill bits or hard metal percussion drill bits, respectively, according to ISO 5468 should be used. New drill bits should be used for one test series or drill bits with  $d_{cut,m} = 10,25 \text{ mm} < d_{cut} \leq 10,45 \text{ mm} = d_{cut,max}$  (KT 10) or  $d_{cut,m} = 14,25 \text{ mm} < d_{cut} \leq 14,50 \text{ mm} = d_{cut,max}$  (KT 14) respectively.

#### 4.4.3 Execution of test

The test rig used for the pull-out tests shall provide a continuous slow increase of the load, controlled by a calibrated load cell. The load shall apply perpendicular to the surface of the base material and shall be transmitted to the anchor via a hinge. The reaction forces shall be transmitted into the base material such that possible breakout of the masonry is not restricted. This condition is considered as fulfilled, if the support reaction forces are transmitted either in adjacent masonry units or at a distance of at least 150 mm from the plastic anchors. The load shall be increased continuously in a way that the ultimate load is reached after about 1 minute. The load is measured when the ultimate load ( $N_1$ ) is achieved.

If no pull-out failure occurs, other test methods are needed, e.g. proof-loading.

#### 4.4.4 Test report

The test report shall include all information necessary to assess the resistance of the tested anchor. It shall be given to the person responsible for the design of the fastening and shall be included in the construction dossier.

The minimum data required are:

- Name of product
- Construction site, owner of building; date and location of the tests, air temperature
- Test rig
- Type of structure to be fixed
- Masonry (type of brick, strength class, all dimensions of bricks, mortar group if possible); visual assessment of masonry (flush joints, joint clearance, regularity)
- Plastic anchor and special screw

- value of the cutting diameter of hard metal hammer-drill bits, measured before and after drilling if no new drill bits are used
- Results of tests including the indication of value  $N_1$ ; mode of failure
- Tests carried out or supervised by ...; signature

#### 4.4.5 Evaluation of test results

The characteristic resistance  $F_{RK1}$  is derived from the measured values  $N_1$  as follows

$$F_{RK1} = 0,5 \cdot N_1$$

The characteristic resistance  $F_{RK1}$  has to be equal or smaller than the characteristic resistance  $F_{RK}$  which is given in the ETA for similar masonry (bricks or blocks)

$$N_1 = \text{the mean value of the five smallest measured values at ultimate load}$$

In absence of national regulations the partial safety factors for the resistance of the plastic anchor may be taken as  $\gamma_{Mm} = 2,5$  for use in masonry.

## 5 Indications to the manufacturer

### 5.1 Responsibility of the manufacturer

It is in the responsibility of the manufacturer to ensure that the information on the specific conditions according to 1 and 2 including Annexes referred to 4 is given to those who are concerned. This information may be made by reproduction of the respective parts of the European technical approval. In addition, all installation data shall be shown clearly on the packaging and/or on an enclosed instruction sheet, preferably using illustrations.

The minimum data required are:

- base material for the intended use,
- ambient temperature of the base material during installation of the anchor,
- drill bit diameter ( $d_{cut}$ ),
- overall anchor embedment depth in the base material ( $h_{nom}$ ),
- minimum hole depth ( $h_0$ ),
- information on the installation procedure,
- identification of the manufacturing batch.

All data shall be presented in a clear and explicit form.

### 5.2 Packaging, transport and storage

The anchor shall only be packaged and supplied as a complete unit.

The anchor shall be stored under normal climatic conditions in its original light-proof packaging. Before installation, it shall not be extremely dried nor frozen.

Georg Feistel  
Head of Department

*beglaubigt:*  
Bürger

### KEIL Facade Anchor KT 10 and KT 14

Fixing in concrete and solid masonry

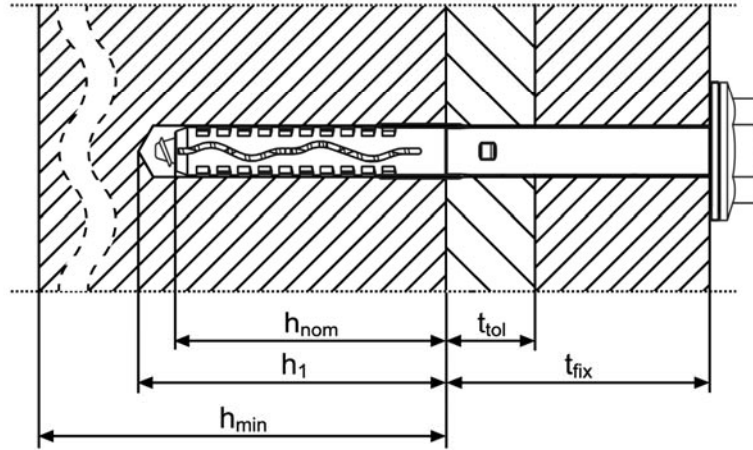

Fixing in hollow or perforated masonry

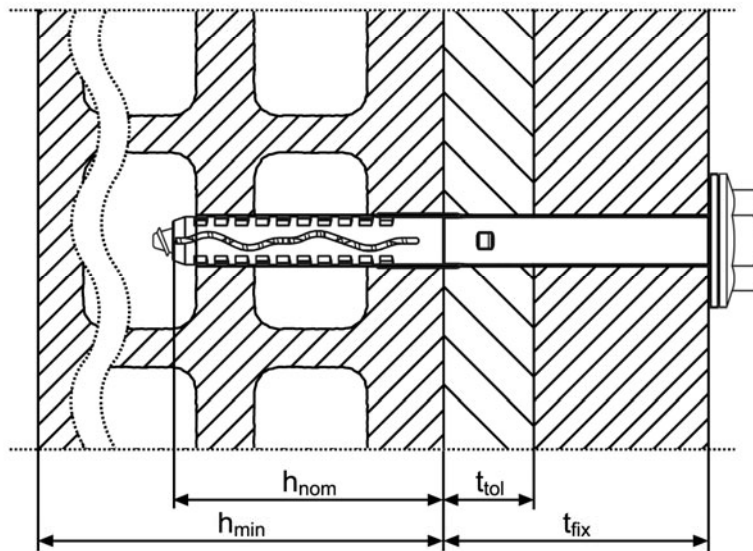

#### Legend

- $h_{nom}$  = overall plastic anchor embedment depth in the base material
- $h_1$  = depth of drilled hole to deepest point
- $h$  = thickness of member (wall)
- $t_{fix}$  = thickness of fixture
- $t_{tol}$  = thickness of layer or non-load bearing coating

KEIL Facade Anchor KT 10 and KT 14

Intended use

**Annex 1**

**Anchor sleeve KT 10**

**Marking:**

- Type
- drill hole diameter
- length of plastic sleeve
- countersunk head (SL) or collar head (KL)
- Producer  
e.g. KT 10x100 SL 

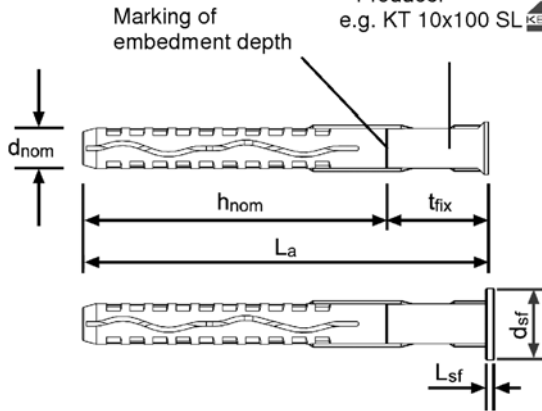

**Anchor sleeve KT 14**

**Marking:**

- Type
- drill hole diameter
- length of plastic sleeve
- countersunk head (SL) or collar head (KL)
- Producer  
e.g. KT 14x100 SL 

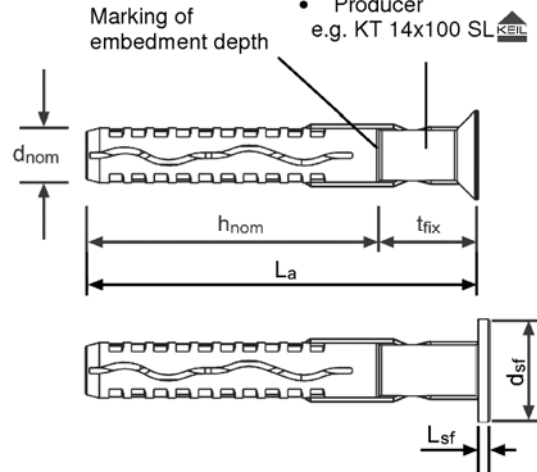

**Special screw KT 10**

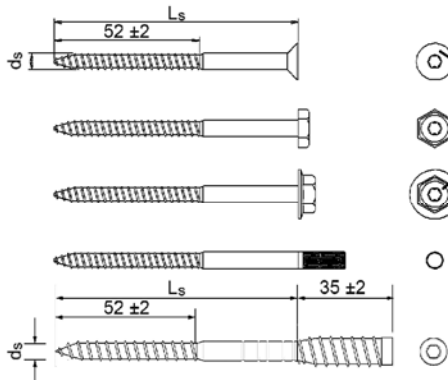

Marking:  
"KTS" or "KT"

**Special screw KT 14**

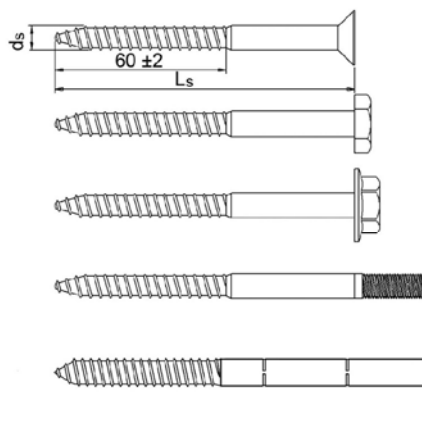

Marking:  
"KTS" or "KT"

**KEIL Facade Anchor KT 10 and KT 14**

Anchor type, special screws

**Annex 2**

**Table 1: Dimensions [mm]**

Type	Anchor sleeve								Special screw <sup>1)</sup>			
	$d_{nom}$ [mm]	$h_{nom}$ [mm]	$t_{fix, min}$ [mm]	$t_{fix, max}$ [mm]	$L_{a, min}$ [mm]	$L_{a, max}$ [mm]	$L_{Sf}$ [mm]	$d_{Sf}$ [mm]	$d_s$ [mm]	$d_k$ <sup>3)</sup> [mm]	$L_{s, min}$ [mm]	$L_{s, max}$ [mm]
KT 10	10	70	10	230	80	300	2	18	7	5.8	90	310
KT 14	14	70	10	290	80	360	3	26	10	8.4	90	370

- 1) To insure that the screw penetrates the anchor sleeve,  $L_s$  must be  $L_a + L_{Sf} + 8$   
 2) Only valid for flat collar version  
 3) core diameter of the thread

**Table 2: Materials**

Name	Material
Anchor sleeve	Polyamide PA6, colour: red, grey
Special screw	Carbon steel, strength class 6.8, electrogalvanic coating Zn $\geq 5 \mu\text{m}$
	Stainless steel, material No. 1.4401, 1.4404 or 1.4571

**Table 3: Installation parameters**

Anchor type		KT 10	KT 14
Drill hole diameter	$d_0 =$ [mm]	10	14
Cutting diameter of drill bit	$d_{cut} \leq$ [mm]	10.45	14.45
Depth of drilled hole to deepest point <sup>1)</sup>	$h_1 \geq$ [mm]	85	85
Overall plastic anchor embedment depth in the base material <sup>1), 2)</sup>	$h_{nom} \geq$ [mm]	70	70
Diameter of clearance hole in the fixture	$d_f \leq$ [mm]	10.5	14.5

- 1) See Annex 1  
 2) For hollow and perforated masonry the influence of  $h_{nom} > 70$  mm has to be detected by job site tests according 4.2.4 and 4.4.

**Table 4: Characteristic bending resistance of the screw in concrete, masonry and AAC**

		KT 10		KT 14	
		gvz	stainless steel	gvz	stainless steel
Characteristic bending resistance	$M_{Rk,s}$ [Nm]	12.8	11.5	36.2	32.6
Partial safety factor	$\gamma_{Ms}$ <sup>1)</sup>	1.25	1.33	1.25	1.33

- 1) In absence of other national regulations

**KEIL Facade Anchor KT 10 and KT 14**

Dimensions, materials,  
installation parameters and  
characteristic bending resistance

**Annex 3**



**Table 5: Characteristic resistance of the screw for use in concrete and masonry**

Failure of expansion element (special screw)		KT 10		KT 14	
		gvz	stainless steel	gvz	stainless steel
Characteristic tension resistance	$N_{Rk,s}$ [kN]	15.0	13.5	30.2	27.1
Partial safety factor	$\gamma_{Ms}^{1)}$	1.5	1.6	1.5	1.6
Characteristic shear resistance	$V_{Rk,s}$ [kN]	7.5	6.8	15.1	13.6
Partial safety factor	$\gamma_{Ms}^{1)}$	1.25	1.33	1.25	1.33

1) In absence of other national regulations

**Table 6: Characteristic resistance for use in concrete**

Pull-out failure (plastic sleeve)		KT 10		KT 14	
		$\vartheta = 24/40$ °C	$\vartheta = 50/80$ °C	$\vartheta = 24/40$ °C	$\vartheta = 50/80$ °C
<b>• Concrete <math>\geq</math> C16/20</b>					
Characteristic resistance	$N_{Rk,p}$ [kN]	5.0	3.5	7.5	5.0
Partial safety factor	$\gamma_{Mc}^{1)}$	1.8			
<b>• Concrete C12/15</b>					
Characteristic resistance	$N_{Rk,p}$ [kN]	3.5	2.5	5.0	3.5
Partial safety factor	$\gamma_{Mc}^{1)}$	1.8			
<b>Concrete cone failure and concrete edge failure for single anchor and anchor group</b>					
Tension load <sup>2)</sup>					
$N_{Rk,c} = 7,2 \cdot \sqrt{f_{ck,cube}} \cdot h_{ef}^{1,5} \cdot \frac{C}{C_{cr,N}} = N_{Rk,p} \cdot \frac{C}{C_{cr,N}}$		with: $h_{ef}^{1,5} = \frac{N_{Rk,p}}{7,2 \cdot \sqrt{f_{ck,cube}}}$ $\frac{C}{C_{cr,N}} \leq 1$			
Shear load <sup>2)</sup>					
$V_{Rk,c} = 0,45 \cdot \sqrt{d_{nom}} \cdot (h_{nom}/d_{nom})^{0,2} \cdot \sqrt{f_{ck,cube}} \cdot C_1^{1,5} \cdot \left(\frac{C_2}{1,5 C_1}\right)^{0,5} \cdot \left(\frac{h}{1,5 C_1}\right)^{0,5}$		with: $\left(\frac{C_2}{1,5 C_1}\right)^{0,5} \leq 1$ $\left(\frac{h}{1,5 C_1}\right)^{0,5} \leq 1$			
$C_1$	Edge distance closest to the edge in loading direction				
$C_2$	Edge distance perpendicular to direction 1				
$f_{ck,cube}$	Nominal characteristic concrete compression strength (based on cubes), value for C50/60 at maximum				
Partial safety factor	$\gamma_{Mc}^{1)}$	1.8			

1) In absence of other national regulations

2) The design method according to ETAG 020, Annex C is to be used

**KEIL Facade Anchor KT 10 and KT 14**

Characteristic resistance in concrete  
(use category "a")

**Annex 4**



**Table 7: Displacements under tension und shear loading in concrete**

Type	Tension load			Shear load		
	F <sup>1)</sup> [kN]	δ <sub>NO</sub> [mm]	δ <sub>N∞</sub> [mm]	F <sup>1)</sup> [kN]	δ <sub>VO</sub> [mm]	δ <sub>V∞</sub> [mm]
<b>KT 10</b>	1.98	0.2	0.4	2.98	1.0	1.5
<b>KT 14</b>	2.98	0.4	0.6	6.11	3.0	4.5

1) Intermediate values by linear interpolation

**Table 8: Minimum thickness of member, edge distance and spacing in concrete**

**KT 10:** Fixing points with a spacing  $s_{cr,N} \leq 85$  mm are considered as a group with a max. characteristic resistance  $N_{Rk,p}$  acc. to Table 6. For  $s_{cr,N} > 85$  mm the anchors are considered as single anchors, each with a characteristic resistance  $N_{Rk,p}$  acc. to Table 6.

**KT 14:** Fixing points with a spacing  $s \leq 115$  mm are considered as a group with a max. characteristic resistance  $N_{Rk,p}$  acc. to Table 6. For  $s > 115$  mm the anchors are considered as single anchors, each with a characteristic resistance  $N_{Rk,p}$  acc. to Table 6.

Type		Minimum thickness of member <b>h<sub>min</sub></b> [mm]	Characteristic edge distance <b>c<sub>cr,N</sub></b> [mm]	Minimum allowable edge distances <b>c<sub>min</sub></b> [mm]	Minimum allowable spacing <b>s<sub>min</sub></b> [mm]
<b>KT 10</b>	Concrete C12/15	100	100	85	70
	Concrete ≥ C16/20		70	60	50
<b>KT 14</b>	Concrete C12/15	100	140	120	105
	Concrete ≥ C16/20		100	85	75

**Scheme of distance and spacing in concrete**

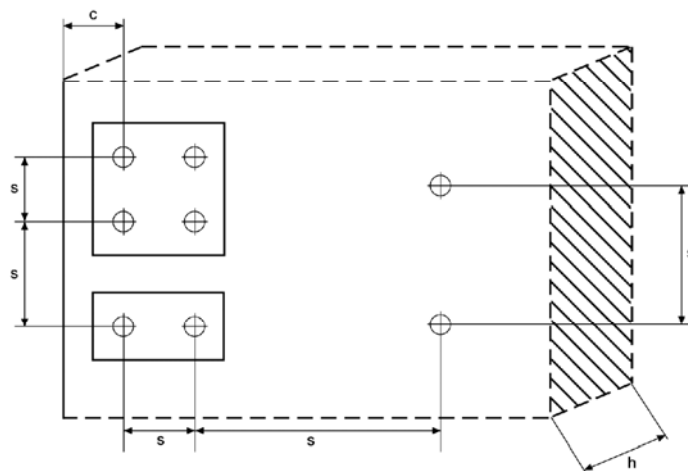

**KEIL Facade Anchor KT 10 and KT 14**

Displacements,  
minimum thickness of member,  
minimum spacing and edge distances in concrete

**Annex 5**

**Table 9: Characteristic resistance  $F_{RK}$  in [kN] in solid and hollow or perforated masonry (use category "b" and "c")**

Use category	Base material	Min. DF or min. size  (L x W x H)  [mm]	Bulk density class  $\rho$  [kg/dm <sup>3</sup> ]	Minimum compressive strength  $f_b$  [N/mm <sup>2</sup> ]	Drill method	Thick- ness of wall  h  [mm]	Figure see Annex	Characteristic resistance $F_{RK}$ <sup>1)</sup> [kN]				
								KT 10		KT 14		
								24/40 °C	50/80 °C	24/40 °C	50/80 °C	
<b>b</b>	Clay brick DIN EN 771-1 Mz-NF	240x115x71	1.8	20	H <sup>2)</sup>	115		4.0	3.5	4.5	4.5 <sup>6)</sup>	
				6.0 <sup>5)</sup>				3.0	7.5 <sup>6)</sup>	5.0 <sup>6)</sup>		
				3.0				2.5	3.0	3.0		
				4.5 <sup>5)</sup>				2.0	5.0 <sup>6)</sup>	3.5 <sup>6)</sup>		
				20				240	6.0 <sup>7)</sup>	3.5 <sup>7)</sup>	/	
				10					5.0 <sup>7)</sup>	2.5 <sup>7)</sup>		
	Solid sand-lime brick DIN EN 771-2 KS-NF	240x115x71	1.8	20	H <sup>2)</sup>	115		1.5	1.5	1.5	1.5	
				10				1.2	1.2	1.2	1.2	
				20				6.0 <sup>7)</sup>	4.0 <sup>7)</sup>	9.0 <sup>6)</sup>	6.0 <sup>6)</sup>	
				10				5.0 <sup>7)</sup>	3.0 <sup>7)</sup>	6.0 <sup>6)</sup>	4.0 <sup>6)</sup>	
	Solid sand-lime brick DIN EN 771-2 KS-2DF	240x115x112	2.0	20	H <sup>2)</sup>	115		4.0	4.0	4.5	4.5 <sup>6)</sup>	
				10				6.0 <sup>5)</sup>	3.0	9.0 <sup>6)</sup>	9.0 <sup>6)</sup>	
<b>c</b>	Hollow clay brick DIN EN 771-1 HLz-2DF	240x115x115	1.0	12	R <sup>3)</sup>	115	7	1.5	0.75	/		
	Hollow sand-lime brick DIN EN 771-2 KSL-8DF	250x240x237	1.4	12	R <sup>3)</sup>	115 <sup>8)</sup>	7	1.2	0.6			
Partial safety factor <sup>4)</sup>						$\gamma_{Mm}$	2.5					

- 1) Characteristic resistance  $F_{RK}$  for tension, shear or combined tension and shear loading.  
The characteristic resistance is valid for single plastic anchor or for a group of two or four plastic anchors with a spacing equal or larger than the minimum spacing  $s_{min}$  according to Table 12 and 13. The specific conditions for the design method have to be considered according to chapter 4.2.6 of the ETA.
- 2) Hammer drilling
- 3) Rotary drilling
- 4) In absence of other national regulations
- 5) Only valid for an edge distance of  $c \geq 150$  mm
- 6) Only valid for an edge distance of  $c \geq 200$  mm
- 7) Only valid for an edge distance of  $c \geq 120$  mm
- 8) Cut brick for reveal

**KEIL Facade Anchor KT 10 and KT 14**

Characteristic resistance  
in solid and hollow or perforated masonry  
(use category "b" and "c")

**Annex 6**

**Table 10: Displacements under tension und shear loading in solid and hollow or perforated masonry**

Type	Base material <sup>1)</sup>	F [kN]	Displacements [mm]			
			Tension load		Shear load	
			$\delta_{NO}$	$\delta_{N\infty}$	$\delta_{VO}$	$\delta_{V\infty}$
<b>KT 10</b>	Clay brick DIN EN 771-1: Mz-NF	1.71	0.2	0.4	1.4	2.1
	Solid sand-lime brick DIN EN 771-2: KS-NF	0.43	0.2	0.4	0.4	0.5
	Solid sand-lime brick DIN EN 771-2: KS-2DF	1.71	0.2	0.4	1.4	2.1
	Hollow clay brick DIN EN 771-1: HLz-2DF	0.43	0.1	0.2	0.9	1.3
	Hollow sand-lime brick DIN EN 771-2: KSL-8DF	0.34	0.2	0.4	0.7	1.0
<b>KT 14</b>	Clay brick DIN EN 771-1: Mz-NF	2.14	0.2	0.4	1.8	2.7
	Solid sand-lime brick DIN EN 771-2: KS-NF	0.43	0.1	0.2	0.4	0.5
	Solid sand-lime brick DIN EN 771-2: KS-2DF	2.57	0.1	0.2	2.1	3.2
	Solid sand-lime brick DIN EN 771-2: KS-NF (240x240x71)	2.57	1.1	2.2	2.1	3.2

1) Information for base material masonry: see Annex 6, Table 9

**Table 11: Geometry of stones**

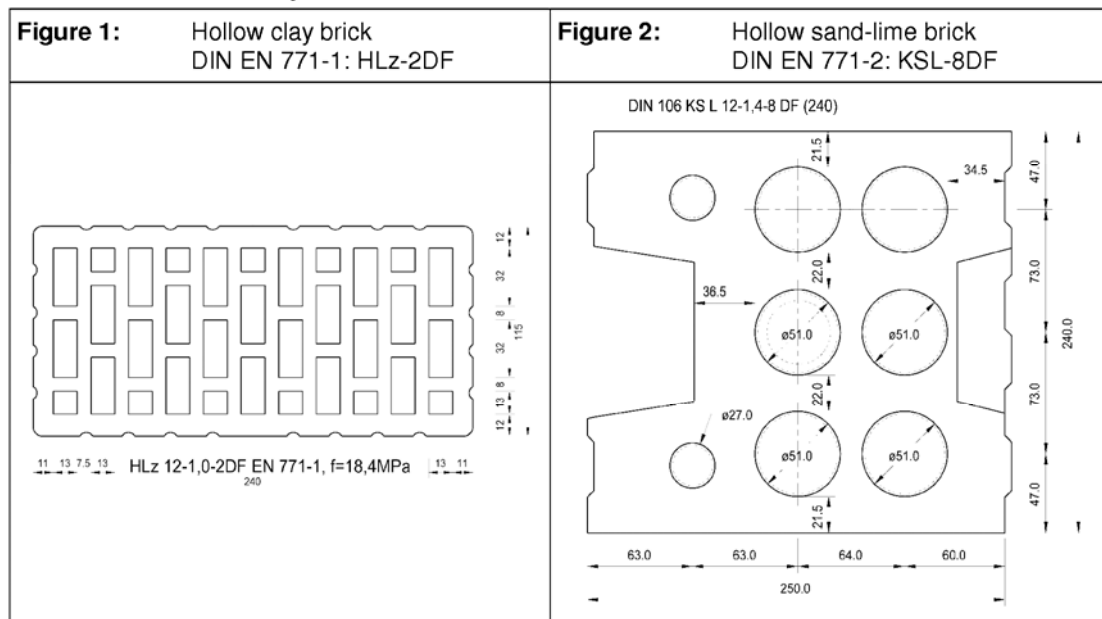

**KEIL Facade Anchor KT 10 and KT 14**

Displacements in solid and hollow or perforated masonry  
Geometry of stones

**Annex 7**

**Table 12: Minimum distances and dimensions in solid masonry**

		KT 10		KT 14	
Minimum thickness of member	$h_{min}$ [mm]	115	240 <sup>2)</sup>	115	240 <sup>1)</sup>
Single anchor					
Minimum allowable spacing	$a_{min}$ [mm]	250		250	
Minimum allowable edge distance	$c_{min}$ [mm]	100	120 <sup>2)</sup>	100	200 <sup>1)</sup>
Anchor Group					
Minimum allowable spacing <b>perpendicular</b> to free edge	$s_{1,min}$ [mm]	200	85 <sup>2)</sup>	200	
Minimum allowable spacing <b>parallel</b> to free edge	$s_{2,min}$ [mm]	400	85 <sup>2)</sup>	400	
Minimum allowable edge distance	$c_{min}$ [mm]	100	120 <sup>2)</sup>	100	

1) Only for KS-NF and member thickness  $h \geq 240$  mm [see Table 9 with footnote 6)]

2) Only for Mz-NF and KS-NF [see Table 9 with footnote 7)]

**Table 13: Minimum distances and dimensions in hollow or perforated masonry  
(only for KT 10)**

		KT 10 in HLz-2DF <sup>1)</sup>	KT 10 in KSL-8DF <sup>1)</sup>
Minimum thickness of member	$h_{min}$ [mm]	115	115
Single anchor			
Minimum allowable spacing	$a_{min}$ [mm]	250	250
Minimum allowable edge distance	$c_{min}$ [mm]	100	60
Anchor Group			
Minimum allowable spacing <b>perpendicular</b> to free edge	$s_{1,min}$ [mm]	100	100
Minimum allowable spacing <b>parallel</b> to free edge	$s_{2,min}$ [mm]	100	100
Minimum allowable edge distance	$c_{min}$ [mm]	100	60

1) Information for base material masonry: see Annex 6, Table 9

**Scheme of distance and spacing in masonry**

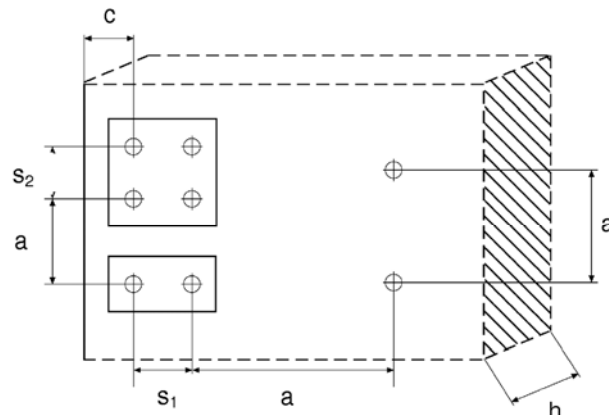

**KEIL Facade Anchor KT 10 and KT 14**

Minimum thickness of member,  
minimum spacing and edge distances in solid masonry and  
hollow or perforated masonry

**Annex 8**

**Table 14: Characteristic resistance  $F_{Rk}$  in [kN] in AAC (use category "d")**

Type	Base material	Bulk density $\rho$ [kg/m <sup>3</sup> ]	Minimum compressive strength $f_{ck}$ [N/mm <sup>2</sup> ]	Drill method	Characteristic resistance $F_{Rk}^{1)}$ [kN]	
					24/40 °C	50/80 °C
KT 10	<b>AAC2, PP2/0,35</b>	$\geq 350$	1.8	R <sup>3)</sup>	0.9	0.75
	<b>AAC6, PP6-0,7</b>	$\geq 650$	5.4	R <sup>3)</sup>	2.5	2.5
	Partial safety factor <sup>2)</sup>	$\gamma_{M,AAC}$			<b>2.0</b>	

- 1) Characteristic resistance  $F_{Rk}$  for tension, shear or combined tension and shear loading.  
The characteristic resistance is valid for single plastic anchor or for a group of two or four plastic anchors with a spacing equal or larger than the minimum spacing  $s_{min}$  according to Table 16. The specific conditions for the design method have to be considered according to chapter 4.2.6 of the ETA.
- 2) In absence of other national regulations
- 3) Rotary drilling

**Table 15: Displacements under tension und shear loading in AAC**

Type	Base material	Tension load			Shear load		
		$F^{1)}$ [kN]	$\delta_{NO}$ [mm]	$\delta_{N\infty}$ [mm]	$F^{1)}$ [kN]	$\delta_{VO}$ [mm]	$\delta_{V\infty}$ [mm]
KT 10	<b>AAC2</b>	0.3	0.2	0.4	0.3	0.6	1.0
	<b>AAC6</b>	0.9	0.2	0.4	0.9	1.8	2.7

- 1) Intermediate values by linear interpolation

**Table 16: Minimum distances and dimensions in AAC**

KT 10		
Minimum thickness of member	$h_{min}$ [mm]	200
Single anchor		
Minimum allowable spacing	$a_{min}$ [mm]	250
Minimum allowable edge distance	$c_{min}$ [mm]	100
Anchor Group		
Minimum allowable spacing <b>perpendicular</b> to free edge	$s_{1,min}$ [mm]	200
Minimum allowable spacing <b>parallel</b> to free edge	$s_{2,min}$ [mm]	400
Minimum allowable edge distance	$c_{min}$ [mm]	100

**Scheme of distance and spacing in AAC**

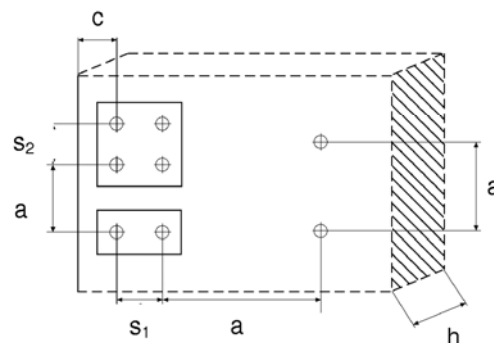

**KEIL Facade Anchor KT 10 and KT 14**

Characteristic resistance, displacements,  
minimum thickness of member, minimum spacing and edge  
distances in AAC

**Annex 9**