



European Technical Approval ETA-09/0002

English translation prepared by DIBt - Original version in German language

Handelsbezeichnung <i>Trade name</i>	fischer-Zykon-Plattenanker FZP-N für Max Exterior - Fassadenplatten <i>fischer-Zykon-panel anchor FZP-N for Max Exterior - facade panels</i>
Zulassungsinhaber <i>Holder of approval</i>	fischerwerke GmbH & Co. KG Weinhalde 14-18 72178 Waldachtal DEUTSCHLAND
Zulassungsgegenstand und Verwendungszweck <i>Generic type and use of construction product</i>	Spezialanker zur rückseitigen Befestigung von Fassadenplatten aus dekorativen Hochdruck-Schichtpressstoffplatten (HPL) nach EN 438-7 <i>Special anchor for the rear fixing of facade panels made of high- pressure decorative laminates (HPL) according to EN 438-7</i>
Geltungsdauer: <i>Validity:</i>	vom <i>from</i> bis <i>to</i> 30 June 2013 30 June 2018
Herstellwerk <i>Manufacturing plant</i>	fischerwerke

Diese Zulassung umfasst
This Approval contains

16 Seiten einschließlich 8 Anhänge
16 pages including 8 annexes

Diese Zulassung ersetzt
This Approval replaces

ETA-09/0002 mit Geltungsdauer vom 10.01.2012 bis 06.01.2014
ETA-09/0002 with validity from 10.01.2012 to 06.01.2014

I LEGAL BASES AND GENERAL CONDITIONS

- 1 This European technical approval is issued by Deutsches Institut für Bautechnik in accordance with:
 - Council Directive 89/106/EEC of 21 December 1988 on the approximation of laws, regulations and administrative provisions of Member States relating to construction products¹, modified by Council Directive 93/68/EEC² and Regulation (EC) N° 1882/2003 of the European Parliament and of the Council³;
 - *Gesetz über das In-Verkehr-Bringen von und den freien Warenverkehr mit Bauprodukten zur Umsetzung der Richtlinie 89/106/EWG des Rates vom 21. Dezember 1988 zur Angleichung der Rechts- und Verwaltungsvorschriften der Mitgliedstaaten über Bauprodukte und anderer Rechtsakte der Europäischen Gemeinschaften (Bauproduktengesetz - BauPG) vom 28. April 1998⁴, as amended by Article 2 of the law of 8 November 2011⁵;*
 - Common Procedural Rules for Requesting, Preparing and the Granting of European technical approvals set out in the Annex to Commission Decision 94/23/EC⁶.
- 2 Deutsches Institut für Bautechnik is authorized to check whether the provisions of this European technical approval are met. Checking may take place in the manufacturing plant. Nevertheless, the responsibility for the conformity of the products to the European technical approval and for their fitness for the intended use remains with the holder of the European technical approval.
- 3 This European technical approval is not to be transferred to manufacturers or agents of manufacturers other than those indicated on page 1, or manufacturing plants other than those indicated on page 1 of this European technical approval.
- 4 This European technical approval may be withdrawn by Deutsches Institut für Bautechnik, in particular pursuant to information by the Commission according to Article 5(1) of Council Directive 89/106/EEC.
- 5 Reproduction of this European technical approval including transmission by electronic means shall be in full. However, partial reproduction can be made with the written consent of Deutsches Institut für Bautechnik. In this case partial reproduction has to be designated as such. Texts and drawings of advertising brochures shall not contradict or misuse the European technical approval.
- 6 The European technical approval is issued by the approval body in its official language. This version corresponds fully to the version circulated within EOTA. Translations into other languages have to be designated as such.

¹ Official Journal of the European Communities L 40, 11 February 1989, p. 12
² Official Journal of the European Communities L 220, 30 August 1993, p. 1
³ Official Journal of the European Union L 284, 31 October 2003, p. 25
⁴ *Bundesgesetzblatt Teil I 1998*, p. 812
⁵ *Bundesgesetzblatt Teil I 2011*, p. 2178
⁶ Official Journal of the European Communities L 17, 20 January 1994, p. 34

II SPECIFIC CONDITIONS OF THE EUROPEAN TECHNICAL APPROVAL

1 Definition of product and intended use

1.1 Definition of the construction product

The fischer-Zykon-panel anchor FZP-N for Max Exterior façade panels is a special anchor made of a crosswise slotted anchor sleeve with an integrated blind rivet. The anchor sleeve and the blind rivet are made of stainless steel. The anchor is put into an undercut drill hole and by pulling the blind rivet it is placed form-fitted and anchored force-controlled.

Annex 1 shows the anchor at built-in state.

1.2 Intended use

The fischer-Zykon-panel anchor FZP-N may be used for the rear fixing of Max Exterior façade panels. The façade panels shall be made of High-pressure decorative laminates (HPL) according to EN 438-7 and shall correspond to the specifications given in this ETA.

The façade panels with rear fixing by the anchor may be used for front curtain walls. Each façade panel shall be fixed technically strain-free with at least four anchors in a rectangular arrangement via single agraffes, double agraffes or panel load-bearing profiles on a capable substructure.

The anchor may be used in structures subject to dry internal conditions and also in structures subject to external atmospheric exposure (including industrial and marine environment), if no particular aggressive conditions exist. Such particular aggressive conditions are e.g. permanent, alternating immersion in seawater or the splash zone of seawater, chloride atmosphere of indoor swimming pools or atmosphere with extreme chemical pollution (e.g. in desulphurisation plants or road tunnels where de-icing materials are used).

The provisions made in this European technical approval are based on an assumed working life of the anchor of 50 years. The indications given on the working life cannot be interpreted as a guarantee given by the producer, but are to be regarded only as a means for choosing the right products in relation to the expected economically reasonable working life of the works.

2 Characteristics of the product and method of verification

2.1 Characteristics of the product

The anchor corresponds to the drawings and specifications given in Annex 2. The characteristic material values, dimensions and tolerances of the anchor not indicated in Annex 2 shall correspond to the respective values laid down in the technical documentation⁷ of this European technical approval.

The anchor is considered to satisfy the requirements for performance class A1 of the characteristic reaction to fire, in accordance with the provisions of EC decision 96/603/EC (as amended) without the need for testing on the basis of its listing in that decision.

⁷ The technical documentation comprises all information necessary for the production, installation and maintenance of the anchor; these are in particular the design drawings and the installation instructions. The part to be treated confidentially is deposited with Deutsches Institut für Bautechnik and, as far as this is relevant to the tasks of the approved bodies involved in the procedure of attestation of conformity, shall only be handed over to the approved body.

In addition to the specific clauses relating to dangerous substances contained in this European technical approval, there may be other requirements applicable to the products falling within its scope (e.g. transposed European legislation and national laws, regulations and administrative provisions). In order to meet the provisions of the Construction Products Directive, these requirements need also to be complied with, when and where they apply.

The characteristic values for the design of the façade panels and the anchor are given in Annex 5.

Every anchor is marked with the identifying mark of the producer and the anchor size according to Annex 2

The Anchor shall only be packaged and supplied as a complete unit (anchor sleeve and blind rivet).

2.2 Methods of verification

The assessment of fitness of the anchor for the intended use in relation to the requirement for safety in use in the sense of the essential requirement N°4 of Council Directive 89/106/EEC has been made based on the following tests:

- (1) Axial tension tests
- (2) Shear tests
- (3) Tests with combined tension and shear loading
- (4) Tests on structural members
- (5) Tests on functioning under repeated loads
- (6) Tests on functioning under sustained loads
- (7) Tests on functioning under freeze/thaw conditions (25 freeze/thaw cycles)
- (8) Tests on functioning after immersion in water.
- (9) Tests on functioning under temperature

3 Evaluation and attestation of conformity and CE marking

3.1 System of attestation of conformity

According to the communication of the European Commission⁸ the system 2 (ii)-1 (referred to as System 2+) of attestation of conformity applies.

These systems of attestation of conformity are defined as follows:

System 2+: Declaration of conformity of the product by the manufacturer on the basis of:

- (a) Tasks for the manufacturer:
 - (1) initial type-testing of the product;
 - (2) factory production control;
 - (3) testing of samples taken at the factory in accordance with a prescribed test plan.
- (b) Tasks for the approved body:
 - (4) certification of factory production control on the basis of:
 - initial inspection of factory and of factory production control;
 - continuous surveillance, assessment and approval of factory production control.

⁸

Letter of the European Commission of 22/07/2002 to EOTA

3.2 Responsibilities

3.2.1 Tasks for the manufacturer

3.2.1.1 Factory production control

The manufacturer shall exercise permanent internal control of production. All the elements, requirements and provisions adopted by the manufacturer shall be documented in a systematic manner in the form of written policies and procedures, including records of results performed. This production control system shall insure that the product is in conformity with this European technical approval.

The manufacturer may only use initial materials and components stated in the technical documentation of this European technical approval.

The factory production control shall be in accordance with the control plan⁹ of January 2009 which is part of the technical documentation of this European technical approval. The control plan is laid down in the context of the factory production control system operated by the manufacturer and deposited with Deutsches Institut für Bautechnik.

The results of factory production control shall be recorded and evaluated in accordance with the provisions of the control plan.

3.2.1.2 Other tasks for the manufacturer

The manufacturer shall, on the basis of a contract, involve a body which is approved for the tasks referred to in section 3.1 in the field of "anchors" in order to undertake the actions laid down in section 3.2.2. For this purpose, the control plan referred to in sections 3.2.1.1 and 3.2.2 shall be handed over by the manufacturer to the approved body involved.

The manufacturer shall make a declaration of conformity, stating that the construction product is in conformity with the provisions of this European technical approval.

3.2.2 Tasks of approved bodies

The approved body shall perform the following tasks in accordance with the provisions laid down in the control plan:

- initial inspection of factory and of factory production control,
- continuous surveillance, assessment and approval of factory production control.

The approved body shall retain the essential points of its actions referred to above and state the results obtained and conclusions drawn in a written report.

The approved certification body involved by the manufacturer shall issue an EC certificate of conformity of the factory production control stating the conformity with the provisions of this European technical approval.

In cases where the provisions of the European technical approval and its "control plan" are no longer fulfilled the certification body shall withdraw the certificate of conformity and inform Deutsches Institut für Bautechnik without delay.

⁹ The control plan is a confidential part of the European technical approval and only handed over to the approved body involved in the procedure of attestation of conformity. See section 3.2.2.

3.3 CE marking

The CE marking shall be affixed on the packaging or accompanying commercial document, e.g. the EC declaration of conformity. The letters "CE" shall be followed by the identification number of the approved certification body, where relevant, and be accompanied by the following additional information:

- the name and address of the producer (legal entity responsible for the manufacturer),
- the last two digits of the year in which the CE marking was affixed,
- the number of the EC certificate for the factory production control,
- the number of the European technical approval,
- use category (25 freeze/thaw cycles),
- size.

4 Assumptions under which the fitness of the product for the intended use was favourably assessed

4.1 Manufacture

The anchor is manufactured in accordance with the provisions of the European technical approval using the automated manufacturing process as identified in the inspection of the plant by Deutsches Institut für Bautechnik and the approved body and laid down in the technical documentation.

The European technical approval is issued for the product on the basis of agreed data/information, deposited with Deutsches Institut für Bautechnik, which identifies the product that has been assessed and judged. Changes to the product or production process, which could result in this deposited data/information being incorrect, should be notified to Deutsches Institut für Bautechnik before the changes are introduced. Deutsches Institut für Bautechnik will decide whether or not such changes affect the ETA and consequently the validity of the CE marking on the basis of the ETA and if so whether further assessment or alterations to the ETA shall be necessary.

4.2 Installation

4.2.1 Design of the fixings

The fitness of the anchor for the intended use is given under the following conditions:

- the Max Exterior façade panels are classified according to EN 438-7 "High-pressure decorative laminates (HPL) and fulfil the requirements of type EDF according to EN 438-6
- each façade panel is fixed with at least four anchors in a rectangular arrangement via single agraffes, double agraffes or panel load-bearing profiles on the substructure
- the anchors are built-in according to Annex 1 with a spacer according to Annex 2 (stand-off fixing)
- the substructure is constructed such that the façade panels are fixed according to Annex 5 technically strain-free via skids (loose bearings) and one fixed point (fixed bearing); the fixed point may be placed at the panel edge or in the panel field
- two fixing points of the façade panel are designed such that they are able to carry the dead load of the façade panel
- when using agraffes on horizontal load-bearing profiles the fixing points of a façade panel situated horizontally at the same height are fastened in each case to the same load-bearing profile
- the thickness of the fixing member (agraffe or panel load-bearing profile) shall be at least 2.0 mm and must not exceed 3.0 mm

- subjected to the thickness of the fixing member of the respective case of application the spacer is chosen according to Annex 2
- at the panel load-bearing profiles shall be arranged respectively one round hole with \varnothing 9.2 mm (fixed point) and additional holes as slotted hole with the dimension 9.2 mm x 20.0 mm to ensure a strain-free bearing of the façade panels at panel load-bearing profile (see Annex 3)
- the façade panels neither are used to transmit impact loads nor for guard rail
- joint construction between the façade panels is done by a joint filler or are kept open; it is ensured that additional stresses (e.g. by temperature) do not lead to important additional loadings
- taking account of the loads to be fixed checkable calculations and construction drawings are prepared; the position of the anchor is given in the construction drawing
- the façade panels, their fixings as well as the substructure including its connection to wall brackets and their connection to the construction works are designed for the respective case of application under the responsibility of an engineer skilled in the field of façade construction taking account the conditions given in Annex 7 to Annex 8
- for the design relevant characteristic values of the anchor (resistance) as well as the characteristic values of the façade panels (bending strength, modulus of elastic, specific weight) are taken from Annex 5
- the edge distances, spacing and anchorage depth of the anchor as well as the nominal panel thickness of the façade panels according to Annex 5 are observed

4.2.2 Installation of the anchors

The fitness for use of the anchor can be assumed only, if the following installation conditions are observed:

- installation by appropriately qualified personnel under the supervision of the project supervisor
- installation only as delivered by the manufacturer without exchanging the individual parts
- installation according to manufacturer's specifications and construction drawings using the tools indicated in the installation instructions
- keeping of the edge distance and spacing to the specified values
- making of the undercut drilling on the backside of the façade panels is done at the factory or on site under workshop conditions with the transportable drilling device BFZ 100 of the company fischerwerke and with the drill bit according to Annex 3 and in accordance with the information deposited with Deutsches Institut für Bautechnik; the execution is supervised by the responsible project supervisor or a skilled representative of the project supervisor
- cleaning of the drill hole
- in case of aborted hole: new drilling at a minimum distance away of twice the depth of the aborted hole
- keeping of the anchorage depth

- the geometry of the drill hole is checked on 1 % of all drillings; the following dimensions shall be checked and documented according to manufacturer's information and testing instructions by means of the testing and measuring devices according to Annex 4:
 - diameter of the cylindrical drill hole with testing device DPL
 - volume of the undercut with testing device HVL
 - drill hole depth with calliper
 - diameter of the undercut with dial gauge every 500 drill holes or if the drill is changedif the tolerances are exceeded, the geometry of the drill hole shall be checked on 25% of the drillings performed; no further drill hole may exceed the tolerances otherwise all the drill holes shall be controlled; drilling holes falling below or exceeding the tolerances shall be rejected
Note: Checking the geometry of the drill hole on 1% of all drillings means that on one of 100 drillings shall be checked. If the tolerances given in Annex 3 are exceeded the extend of the control shall be increase to 25% of the drillings, i.e. every fourth drilling shall be checked.
- the installation of the anchor is performed with a hand- or accumulator riveter according to the installation instructions
- the positive fit of the anchor in the drill hole is checked by visual inspection; the sleeve shall lock up flush with the fixing member and there shall be no gap between façade panel, spacer and fixing member
- During transport and storage on site the façade panels are protected from damages; the façade panels are not be hung up jerkily (if need be lifters shall be used for hanging up the façade panels); façade panels and reveal panels respectively with incipient cracks are not be installed

5 Indications to the manufacturer

It is in the responsibility of the manufacturer to ensure that the information on the specific conditions according to 1 and 2 including Annexes referred to and 4.2.1 and 4.2.2 is given to those who are concerned. This information may be made by reproduction of the respective parts of the European technical approval. In addition all installation data shall be shown clearly on the package and/or on an enclosed instruction sheet, preferably using illustration(s).

The minimum data required are:

- drill hole depth
- thickness of the fixing member
- thickness of the spacer
- information on the installation procedure, including cleaning of the hole, preferably by means of an illustration

All data shall be presented in a clear and explicit form.

Georg Feistel
Head of Department

beglaubigt:
Aksünger

Example of a façade panel with fixing member – single agraffe

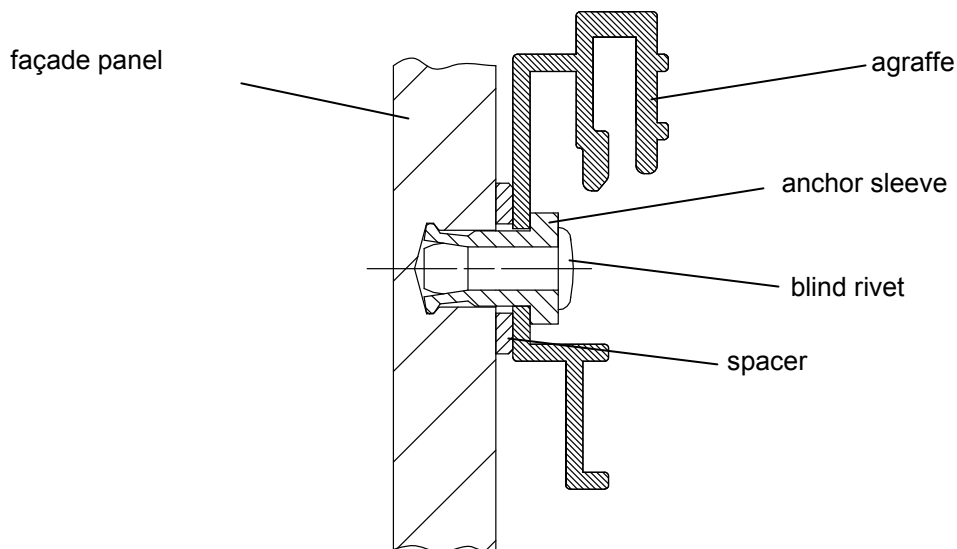

Example of a façade panel with fixing member - panel load-bearing profile

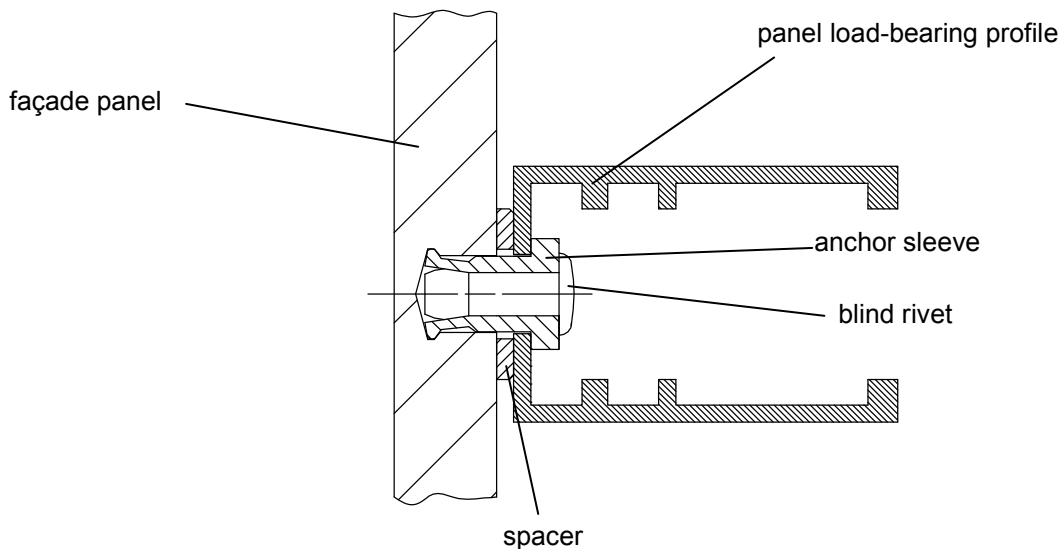

Electronic copy of the ETA by DIBt: ETA-09/0002

fischer-Zykon-panel anchor FZP-N for Max Exterior - facade panels

Product and intended use

Annex 1

System components

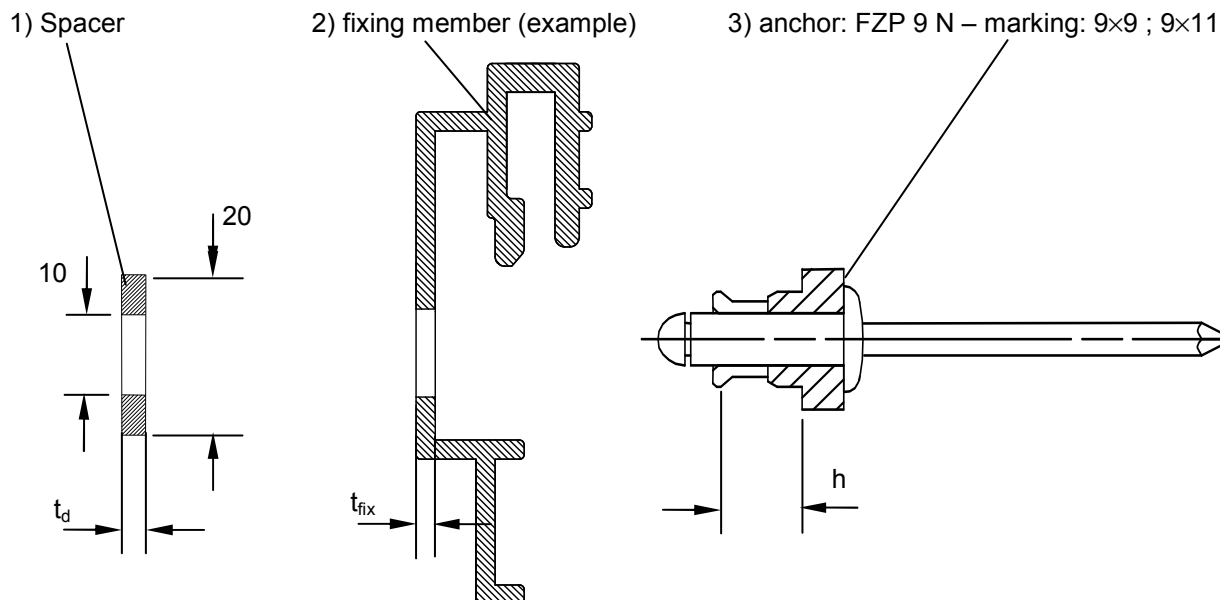

Table 1: system components

part	designation		
1	spacer		
2	fixing member		
3	panel anchor	FZP 9 x 9 N	h = 9 mm
		FZP 9 x 11 N	h = 11 mm

Table 2: classification of spacer dependent of the thickness to fixing member

anchor	thickness of fixing member t_{fix}	spacer		
		thickness t_d	colour	marking
FZP 9 x 9 N FZP 9 x 11 N	2 mm	3 mm	red	2.0
	2.5 mm	2.5 mm	grey	2.5
	3 mm	2 mm	green	3.0

[mm]

fischer-Zykon-panel anchor FZP-N for Max Exterior - facade panels

System components

Annex 2

Drill and drill hole geometry

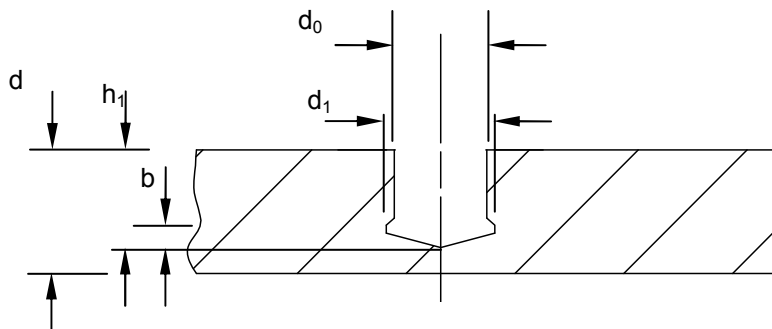
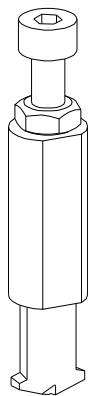

1. drill FZPB 9/N

2. drill hole geometry

anchor type: FZP 9 N		FZP 9 x 9 N	FZP 9 x 11 N
nominal panel thickness	$d =$ [mm]	8	10 ; 12
drill hole depth	$h_1 =$ [mm]	6.5 (± 0.1)	8.5 (± 0.1)
drill hole diameter (tolerance)	$d_o =$ [mm]	9 (-0/+0.3)	
undercut diameter (tolerance)	$d_1 =$ [mm]	11 (-0/+0.4)	
drill bit	$b =$ [mm]	2.5	

Geometry of clearance hole at fixing member (agraffe or panel load-bearing profile) for fixed point (fixed bearing) and skid (loose bearing)

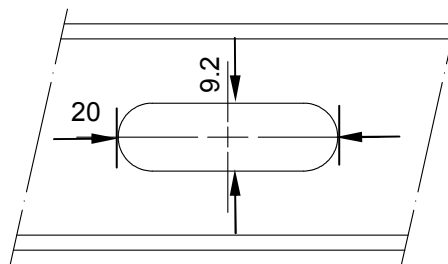
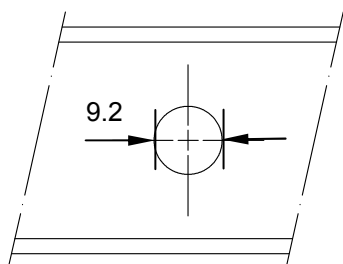

1. round hole: at agraffe and panel load-bearing profile (fixed point)

2. slotted hole: at panel load-bearing profile (skid)

fischer-Zykon-panel anchor FZP-N for Max Exterior - facade panels

Drill and drill hole geometry
Geometry of clearance hole at mounted part

Annex 3

Testing device

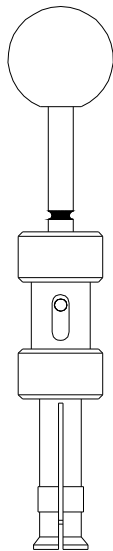

1. undercut-volume-gauge (HVL)



2. diameter-testing-gauge (DPL)

Measuring device

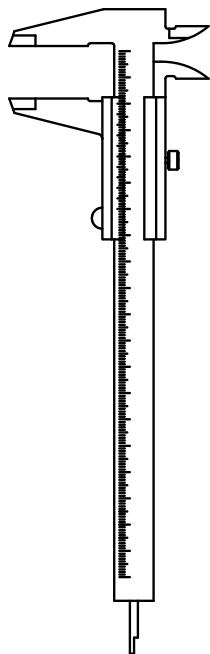

1. calliper

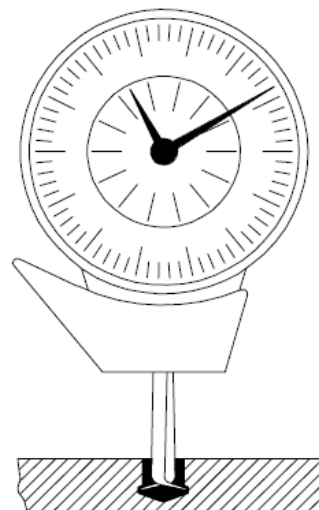

2. dial gauge

fischer-Zykon-panel anchor FZP-N for Max Exterior - facade panels

Testing and measuring device

Annex 4

Table 3: Characteristic values for the design of the anchor and façade panel³⁾

characteristic values of Max Exterior façade panel	nominal panel thickness	$d \geq$	[mm]	8	10	12	
	char. resistance to bending stress	$\sigma_{Rk} =$	[N/mm ²]	52.0			
	partial safety factor ¹⁾	$\gamma_M =$	[-]	1.8			
	modulus of elasticity	$E =$	[N/mm ²]	9000			
	specific weight	$\gamma =$	[kN/m ³]	13.2			
characteristic values of anchors fischer-Zykon-undercut anchor	anchor type	FZP-N	[-]	9 x 9	9 x 11		
	anchorage depth	$h_v =$	[mm]	4	6		
	char. resistance to ²⁾	tension load	$N_{Rk} =$	[kN]	1.7	2.0	2.2
		shear load	$V_{Rk} =$	[kN]	4.6	6.2	6.8
	edge distance	$a_r \geq$	[mm]	50			
	spacing	$a \geq$	[mm]	100			
	partial safety factor ¹⁾	$\gamma_M =$	[-]	1.8			

1) In absence of other national regulations.

2) In case of coincident stress of an anchor due to tension and shear load the equation according to Annex 7 shall be observed.

3) The installation of the 9 x 9 anchor in plates with a nominal thickness of 10 mm or 12 mm is allowed.

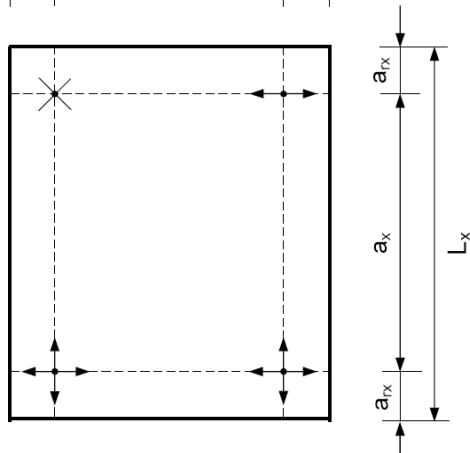
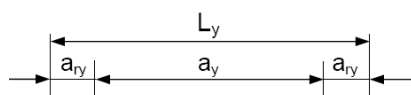

Legend:

a_r = edge distance – distance of an anchor to the panel edge

$a_{x/y}$ = spacing – distance between anchors

L_x = greater length of the façade panel

L_y = smaller length of the façade panel

X = fixed point (fixed bearing)

↔ = horizontal skid (loose bearing)

↕ = horizontal and vertical skid (loose bearing)

fischer-Zykon-panel anchor FZP-N for Max Exterior - facade panels

Characteristic values for the design of the anchor and façade panel

Annex 5

Example of a façade construction with
agraffes

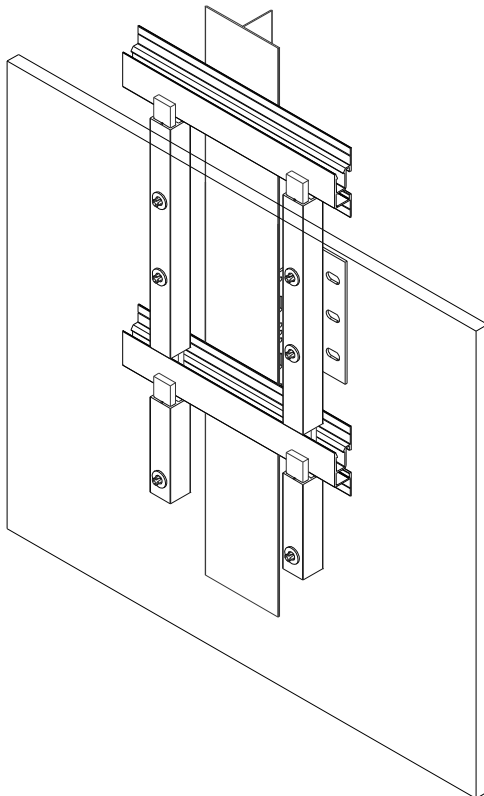
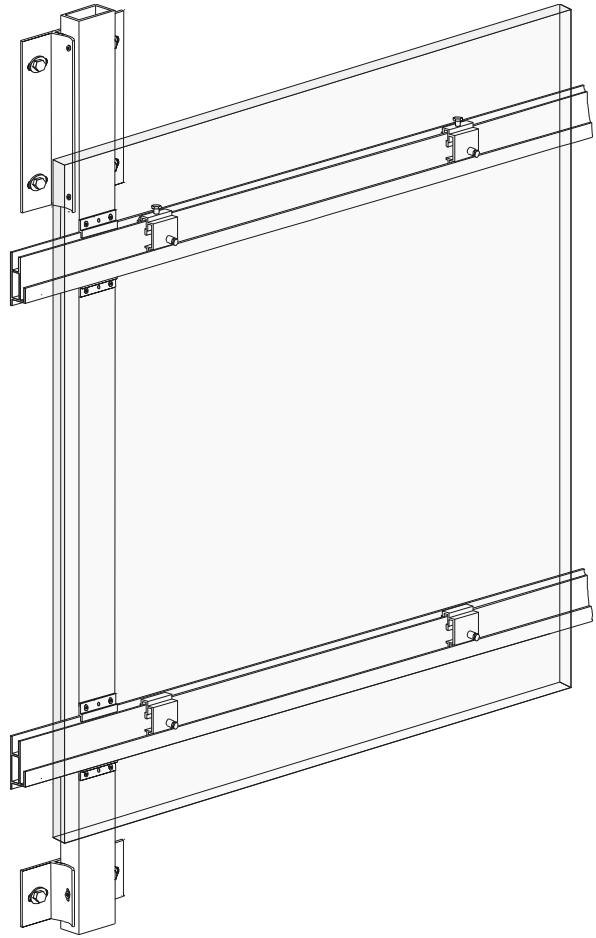

Example of a façade construction with
panel load-bearing profiles

fischer-Zykon-panel anchor FZP-N for Max Exterior - facade panels

Examples of façade constructions

Annex 6

Design method

General

The design values of the actions shall be calculated on basis of EN 1990 in consideration of the existing loads. The combinations of actions shall be equal to EN 1990. The actions shall be specified according to EN 1991-1-1 to EN 1991-1-7. Corresponding national regulations shall be taking into consideration. The unfavourable combination is decisive. Where necessary for the design of the anchor and the façade panel several combinations shall be analysed separately.

The typical fundamental combination for façade panels considers actions from dead load $F_{Sk,G}$ (permanent action), wind $F_{Sk,w}$ (leading variable action) and from mounting restraint $F_{Sk,Zw}$ (permanent load towards the anchor axis).

According to EN 1990 the following fundamental combination depending on the load direction results for a vertical façade panel:

Fundamental combination for loads parallel to the panel:

$$F_{Sd||} = F_{Sk,G} \cdot \gamma_G$$

Fundamental combination for loads perpendicular to the panel:

$$F_{Sd\perp} = F_{Sk,w} \cdot \gamma_Q + F_{Sk,Zw} \cdot \gamma_G$$

$$\text{with } \gamma_G = 1.35; \gamma_Q = 1.50$$

For hanging panels (over head mounting) or reveals respectively the load direction shall be taking into consideration and the combinations of actions shall be based on EN 1990.

For mounting restraint a load of $F_{Sk,Zw} = 0.05 \text{ kN}$ shall be applied. National regulations shall be taking into consideration.

The design values of the actions shall be compared with the design values of the resistance.

Determination and Verification of the Anchor loads

The determination of the anchor loads shall be carried out in a linear elastic manner. The stiffness of the substructure shall be considered for the respective case of application.

For structural calculation by means of the Finite-Element-Method the façade panels are to be idealized with their effective dimensions (size and thickness) as panel elements; the system chosen shall have the capacity to sufficiently precise represent the tension and the deformation state as well as the support reactions of the façade panels. The mesh size at fixing range shall not exceed 50 mm.

When using horizontal load-bearing profiles it shall be verified that

- the agraffes do not prop on the façade panel due to torsion of the horizontal load-bearing profile and twisting of the façade panel
- the total of the angle α results from torsion of the horizontal load-bearing profile and twisting of the façade panel at the fixing point does not exceed the value $\alpha = 2^\circ$

For the anchors loads it shall be verified, that the following equations are observed:

$$\text{Equation 1: } \frac{N_{Sd}}{N_{Rd}} \leq 1$$

$$\text{Equation 2: } \frac{V_{Sd}}{V_{Rd}} \leq 1$$

$$\text{Equation 3: } \left(\frac{N_{Sd}}{N_{Rd}} \right)^{1.5} + \left(\frac{V_{Sd}}{V_{Rd}} \right)^{1.5} \leq 1$$

With:

N_{Sd} = design value of existing anchor tension load

V_{Sd} = design value of existing anchor shear load

N_{Rd} = design value of anchor load-bearing capacity for tension load:

$$N_{Rd} = N_{Rk} / \gamma_M \text{ (with } N_{Rk} \text{ and } \gamma_M \text{ according to Annex 5)}$$

V_{Rd} = design value of anchor load-bearing capacity for shear load:

$$V_{Rd} = V_{Rk} / \gamma_M \text{ (with } V_{Rk} \text{ and } \gamma_M \text{ according to Annex 5)}$$

fischer-Zykon-panel anchor FZP-N for Max Exterior - facade panels

Design method

Annex 7

Verification of the load-bearing capacity of the façade panel

The verification of the load-bearing capacity of the façade panels is deemed to be fulfilled if the following conditions are observed:

Condition 1 – Limitation of the wind load:

The characteristic value of the wind load shall not exceed the following value:

$$q_{Sk,w} \leq 2.5 \text{ kN/m}^2$$

Condition 2 – Limitation of the span moment:

The distance between supports (spacing of anchors) shall be limited as follows:

		panel thickness d		
		8 mm	10 mm	12 mm
spacing a_x	$\leq [m]$	0.80	1.00	1.20
spacing a_y	$\leq [m]$			

Condition 3 - Limitation of the support moment:

- For systems with uniform bearing the following equation shall be observed:

$$q_{Sd} \text{ [kN/m}^2] \leq \frac{d^2}{(7.5 \cdot a_y + 1.6) \cdot a_x \cdot (2 + d)} \text{ [kN/m}^2]$$

(This equation may be omitted for systems with 4 anchors)

- For systems with non-uniform bearing the following equation shall be observed:

$$N_{Sd} \text{ [kN]} \leq \frac{d^2}{((7.0 - 5.0 \cdot a_y) \cdot a_x + 7.5) \cdot (2 + d)} \text{ [kN]}$$

(This equation may be omitted for systems with 4 anchors or anchors in the corner, if the edge distance is $a_r \leq 150 \text{ mm}$)

- With:
- a_x [m] = greater distance between anchors ($a_x \geq a_y$)
 - a_y [m] = smaller distance between anchors ($a_y \leq a_x$)
 - d [mm] = nominal panel thickness
 - q_{Sd} [kN/m²] = design value of the existing wind load
 - N_{Sd} [kN] = design value of the existing anchor tension load

fischer-Zykon-panel anchor FZP-N for Max Exterior - facade panels

Design method

Annex 8