



European Technical Approval ETA-09/0383

English translation prepared by DIBt - Original version in German language

Handelsbezeichnung <i>Trade name</i>	TOX Bolzenanker B/B-U <i>TOX Wedge anchor B/B-U</i>
Zulassungsinhaber <i>Holder of approval</i>	TOX-Dübel-Technik GmbH Brunnenstraße 31 72505 Krauchenwies-Ablach DEUTSCHLAND
Zulassungsgegenstand und Verwendungszweck <i>Generic type and use of construction product</i>	Kraftkontrolliert spreizender Dübel in den Größen M6, M8, M10, M12, M16 und M20 zur Verankerung im ungerissenen Beton <i>Torque controlled expansion anchor of sizes M6, M8, M10, M12, M16 and M20 for use in concrete</i>
Geltungsdauer: <i>Validity:</i>	vom <i>from</i> bis <i>to</i> 4 June 2013 4 June 2018
Herstellwerk <i>Manufacturing plant</i>	TOX Werk 10, Deutschland

Diese Zulassung umfasst
This Approval contains

22 Seiten einschließlich 15 Anhänge
22 pages including 15 annexes

Diese Zulassung ersetzt
This Approval replaces

ETA-09/0383 mit Geltungsdauer vom 05.04.2011 bis 18.02.2016
ETA-09/0383 with validity from 05.04.2011 to 18.02.2016

I LEGAL BASES AND GENERAL CONDITIONS

- 1 This European technical approval is issued by Deutsches Institut für Bautechnik in accordance with:
 - Council Directive 89/106/EEC of 21 December 1988 on the approximation of laws, regulations and administrative provisions of Member States relating to construction products¹, modified by Council Directive 93/68/EEC² and Regulation (EC) N° 1882/2003 of the European Parliament and of the Council³;
 - *Gesetz über das In-Verkehr-Bringen von und den freien Warenverkehr mit Bauprodukten zur Umsetzung der Richtlinie 89/106/EWG des Rates vom 21. Dezember 1988 zur Angleichung der Rechts- und Verwaltungsvorschriften der Mitgliedstaaten über Bauprodukte und anderer Rechtsakte der Europäischen Gemeinschaften (Bauproduktengesetz - BauPG) vom 28. April 1998⁴, as amended by Article 2 of the law of 8 November 2011⁵;*
 - Common Procedural Rules for Requesting, Preparing and the Granting of European technical approvals set out in the Annex to Commission Decision 94/23/EC⁶;
 - Guideline for European technical approval of "Metal anchors for use in concrete - Part 2: Torque controlled expansion anchors ", ETAG 001-02.
- 2 Deutsches Institut für Bautechnik is authorized to check whether the provisions of this European technical approval are met. Checking may take place in the manufacturing plant. Nevertheless, the responsibility for the conformity of the products to the European technical approval and for their fitness for the intended use remains with the holder of the European technical approval.
- 3 This European technical approval is not to be transferred to manufacturers or agents of manufacturers other than those indicated on page 1, or manufacturing plants other than those indicated on page 1 of this European technical approval.
- 4 This European technical approval may be withdrawn by Deutsches Institut für Bautechnik, in particular pursuant to information by the Commission according to Article 5(1) of Council Directive 89/106/EEC.
- 5 Reproduction of this European technical approval including transmission by electronic means shall be in full. However, partial reproduction can be made with the written consent of Deutsches Institut für Bautechnik. In this case partial reproduction has to be designated as such. Texts and drawings of advertising brochures shall not contradict or misuse the European technical approval.
- 6 The European technical approval is issued by the approval body in its official language. This version corresponds fully to the version circulated within EOTA. Translations into other languages have to be designated as such.

¹ Official Journal of the European Communities L 40, 11 February 1989, p. 12
² Official Journal of the European Communities L 220, 30 August 1993, p. 1
³ Official Journal of the European Union L 284, 31 October 2003, p. 25
⁴ *Bundesgesetzblatt Teil I 1998*, p. 812
⁵ *Bundesgesetzblatt Teil I 2011*, p. 2178
⁶ Official Journal of the European Communities L 17, 20 January 1994, p. 34

II SPECIFIC CONDITIONS OF THE EUROPEAN TECHNICAL APPROVAL

1 Definition of product and intended use

1.1 Definition of the construction product

The TOX Wedge Anchor B/B-U in the range of M6, M8, M10, M12, M16 and M20 is an anchor made of electroplated, hot dipped galvanised steel, stainless steel or high corrossions resistant steel which is placed into a drilled hole and anchored by torque-controlled expansion.

An illustration of the product and intended use is given in Annex 1.

1.2 Intended use

The anchor is intended to be used for anchorages for which requirements for mechanical resistance and stability and safety in use in the sense of the Essential Requirements 1 and 4 of Council Directive 89/106 EEC shall be fulfilled and failure of anchorages made with these products would cause risk to human life and/or lead to considerable economic consequences. The anchor is to be used only for anchorages subject to static or quasi-static loading in reinforced or unreinforced normal weight concrete of strength classes C20/25 at minimum and C50/60 at most according to EN 206:2000-12.

It may be anchored in non-cracked concrete only.

Anchor made of galvanised or hot-dip galvanised steel:

The TOX Wedge Anchor B/B-U made of galvanised or hot-dip galvanised steel may only be used in structures subject to dry internal conditions.

Anchor made of stainless steel

The TOX Wedge anchor B/B-U A4 may be used in structures subject to dry internal conditions and also in structures subject to external atmospheric exposure (including industrial and marine environment), or exposure in permanently damp internal conditions, if no particular aggressive conditions exist. Such particular aggressive conditions are e.g. permanent, alternating immersion in seawater or the splash zone of seawater, chloride atmosphere of indoor swimming pools or atmosphere with extreme chemical pollution (e. g. in desulphurization plants or road tunnels where de-icing materials are used).

Anchor made of high corrosion resistant steel

The TOX Wedge anchor B/B-U HCR may be used in structures subject to dry internal conditions and also in structures subject to external atmospheric exposure, in permanently damp internal conditions or in other particular aggressive conditions. Such particular aggressive conditions are e.g. permanent, alternating immersion in seawater or the splash zone of seawater, chloride atmosphere of indoor swimming pools or atmosphere with chemical pollution (e.g. in desulphurization plants or road tunnels where de-icing materials are used).

The provisions made in this European technical approval are based on an assumed working life of the anchor of 50 years. The indications given on the working life cannot be interpreted as a guarantee given by the producer, but are to be regarded only as a means for choosing the right products in relation to the expected economically reasonable working life of the works.

2 Characteristics of the product and methods of verification

2.1 Characteristics of the product

The anchor corresponds to the drawings and provisions given in the Annexes. The characteristic material values, dimensions and tolerances of the anchor not given in the Annexes shall correspond to the respective values laid down in the technical documentation⁷ of this European technical approval.

The characteristic values for the design of anchorages are given in the Annexes.

Each anchor is marked with the identifying mark of the manufacturing plant, the anchor identity, the anchor size and the maximum thickness of fixture for h_{ef} and $h_{ef,red}$ according to Annex 2 and 9.

The anchor shall only be packaged and supplied as a complete unit.

2.2 Methods of verification

The assessment of fitness of the anchor for the intended use in relation to the requirements for mechanical resistance and stability and safety in use in the sense of the Essential Requirements 1 and 4 has been made in accordance with the "Guideline for European technical approval of Metal Anchors for Use in Concrete", Part 1 "Anchors in general" and Part 2 "Torque-controlled expansion anchors", on the basis of Option 7.

In addition to the specific clauses relating to dangerous substances contained in this European technical approval, there may be other requirements applicable to the products falling within its scope (e.g. transposed European legislation and national laws, regulations and administrative provisions). In order to meet the provisions of the Construction Products Directive, these requirements need also to be complied with, when and where they apply.

3 Evaluation and attestation of conformity and CE marking

3.1 System of attestation of conformity

According to the Decision 96/582/EG of the European Commission⁸ system 2(i) (referred to as system 1) of the attestation of conformity applies.

This system of attestation of conformity is defined as follows:

System 1: Certification of the conformity of the product by an approved certification body on the basis of:

- (a) Tasks for the manufacturer:
 - (1) factory production control;
 - (2) further testing of samples taken at the factory by the manufacturer in accordance with a prescribed control plan;
- (b) Tasks for the approved body:
 - (3) initial type-testing of the product;
 - (4) initial inspection of factory and of factory production control;
 - (5) continuous surveillance, assessment and approval of factory production control.

Note: Approved bodies are also referred to as "notified bodies".

⁷ The technical documentation of this European technical approval is deposited at the Deutsches Institut für Bautechnik and, as far as relevant for the tasks of the approved bodies involved in the attestation of conformity procedure, is handed over to the approved bodies.

⁸ Official Journal of the European Communities L 254 of 08.10.1996

3.2 Responsibilities

3.2.1 Tasks for the manufacturer

3.2.1.1 Factory production control

The manufacturer shall exercise permanent internal control of production. All the elements, requirements and provisions adopted by the manufacturer shall be documented in a systematic manner in the form of written policies and procedures, including records of results performed. This production control system shall insure that the product is in conformity with this European technical approval.

The manufacturer may only use initial / raw / constituent materials stated in the technical documentation of this European technical approval.

The factory production control shall be in accordance with the control plan which is part of the technical documentation of this European technical approval. The control plan is laid down in the context of the factory production control system operated by the manufacturer and deposited with Deutsches Institut für Bautechnik.⁹

The results of factory production control shall be recorded and evaluated in accordance with the provisions of the control plan.

3.2.1.2 Other tasks of manufacturer

The manufacturer shall, on the basis of a contract, involve a body which is approved for the tasks referred to in section 3.1 in the field of in order to undertake the actions laid down in section 3.2.2 For this purpose, the control plan referred to in sections 3.2.1.1 and 3.2.2 shall be handed over by the manufacturer to the approved body involved.

The manufacturer shall make a declaration of conformity, stating that the construction product is in conformity with the provisions of this European technical approval.

3.2.2 Tasks for the approved bodies

The approved body shall perform the

- initial type-testing of the product,
- initial inspection of factory and of factory production control,
- continuous surveillance, assessment and approval of factory production control,

in accordance with the provisions laid down in the control plan.

The approved body shall retain the essential points of its actions referred to above and state the results obtained and conclusions drawn in a written report.

The approved certification body involved by the manufacturer shall issue an EC certificate of conformity of the product stating the conformity with the provisions of this European technical approval.

In cases where the provisions of the European technical approval and its control plan are no longer fulfilled the certification body shall withdraw the certificate of conformity and inform Deutsches Institut für Bautechnik without delay.

3.3 CE marking

The CE marking shall be affixed on each packaging of the anchor. The letters "CE" shall be followed by the identification number of the approved certification body, where relevant, and be accompanied by the following additional information:

- the name and address of the holder of the approval (legal entity responsible for the manufacturer),
- the last two digits of the year in which the CE marking was affixed,

⁹ The control plan is a confidential part of the European technical approval and only handed over to the approved body involved in the procedure of attestation of conformity. See section 3.2.2.

- the number of the EC certificate of conformity for the product,
- the number of the European technical approval,
- the number of the guideline for European technical approval,
- use category (ETAG 001-1 Option 7),
- size.

4 Assumptions under which the fitness of the product for the intended use was favourably assessed

4.1 Manufacturing

The European technical approval is issued for the product on the basis of agreed data/information, deposited with the Deutsches Institut für Bautechnik, which identifies the product that has been assessed and judged. Changes to the product or production process, which could result in this deposited data/information being incorrect, should be notified to the Deutsches Institut für Bautechnik before the changes are introduced. Deutsches Institut für Bautechnik will decide whether or not such changes affect the approval and consequently the validity of the CE marking on the basis of the approval and if so whether further assessment or alterations to the approval shall be necessary.

4.2 Design of anchorages

The fitness of the anchor for the intended use is given under the following conditions:

The anchorages are designed either in accordance with

- ETAG 001 "Guideline for European technical approval of Metal Anchors for use in concrete", Annex C, method A

or in accordance with

- CEN/TS 1992-4:2009, design method A

under the responsibility of an engineer experienced in anchorages and concrete work.

Verifiable calculation notes and drawings are taking account of the loads to be anchored.

The position of the anchor is indicated on the design drawings (e.g. position of the anchor relative to reinforcement or to supports).

4.3 Installation of anchors

The fitness for use of the anchor can only be assumed if the anchor is installed as follows:

- Anchor installation carried out by appropriately qualified personnel and under the supervision of the person responsible for technical matters of the site,
- Use of the anchor only as supplied by the manufacturer without exchanging the components of an anchor,
- Anchor installation in accordance with the manufacturer's specifications and drawings and using the appropriate tools,
- Checks before placing the anchor to ensure that the strength class of the concrete in which the anchor is to be placed is in the range given and is not lower than that of the concrete to which the characteristic loads apply,
- Check of concrete being well compacted, e.g. without significant voids,
- Edge distances and spacing not less than the specified values without minus tolerances,
- Positioning of the drill holes without damaging the reinforcement,

- In case of aborted hole: new drilling at a minimum distance away of twice the depth of the aborted hole or smaller distance if the aborted drill hole is filled with high strength mortar and if under shear or oblique tension load it is not in the direction of load application,
- Cleaning of the hole of drilling dust in accordance with Annex 4 and 11,
- Anchor installation such that the effective anchorage depth is complied with. This compliance is ensured, if the thickness of fixture is not greater than the maximum thickness of fixture marked on the anchor in accordance with Annex 2 and 9 and the hexagon nut is placed at the end of the conical bolt as delivered by the manufacturer,
- Application of the torque moment given in Annex 3 and 10 using a calibrated torque wrench.

5 Responsibility of the manufacturer

The manufacturer is responsible to ensure that the information on the specific conditions according to 1 and 2 including Annexes referred to as well as sections 4.2 and 4.3 is given to those who are concerned. This information may be made by reproduction of the respective parts of the European technical approval. In addition all installation data shall be shown clearly on the package and/or on an enclosed instruction sheet, preferably using illustration(s).

The minimum data required are:

- Diameter of drill bit,
- Thread diameter,
- Maximum thickness of the fixture,
- Minimum effective anchorage depth,
- Minimum hole depth,
- Torque moment,
- Information on the installation procedure, including cleaning of the hole, preferably by means of an illustration,
- Reference to any special installation equipment needed,
- Identification of the manufacturing batch.

All data shall be presented in a clear and explicit form.

Andreas Kummerow
p.p. Head of Department

beglaubigt:
Baderschneider

Wedge Anchor B/B-U electroplated:

Sizes M6, M8, M10, M12, M16, M20

Wedge Anchor B/B-U hot-dip galvanised:

Sizes M8, M10, M12, M16, M20

Wedge Anchor B/B-U stainless steel A4/HCR:

Sizes M6, M8, M10, M12, M16, M20
(technical data from Annex 9)

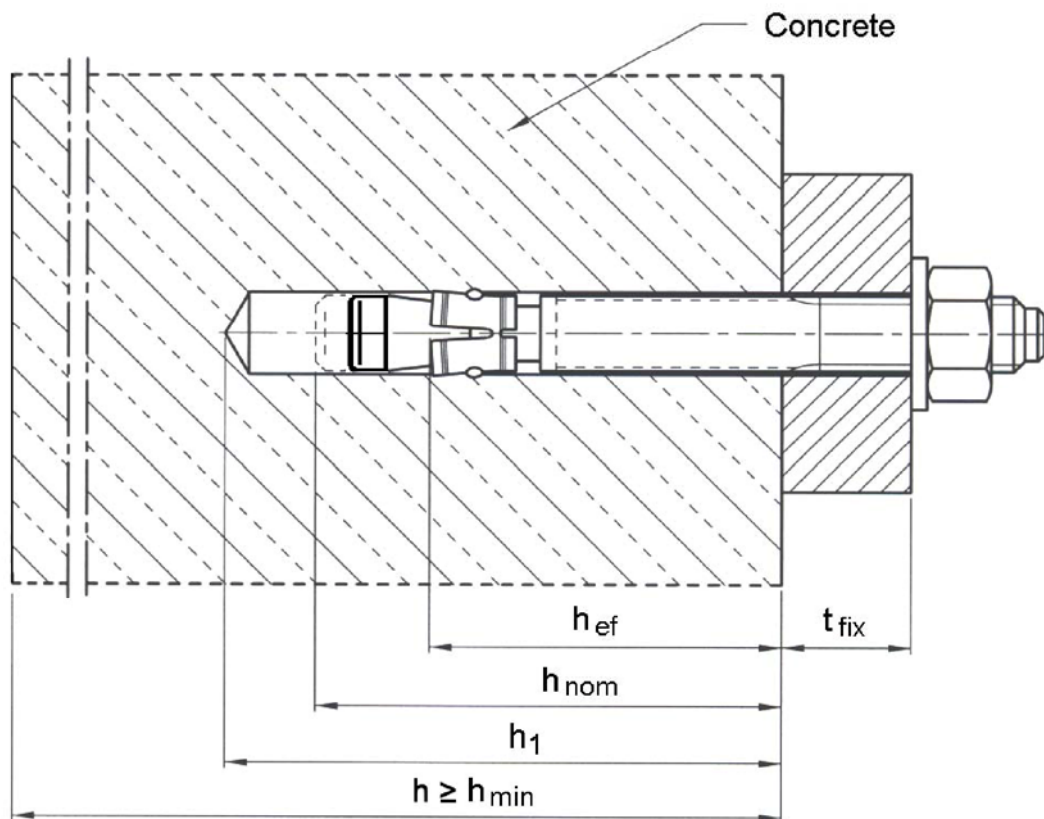
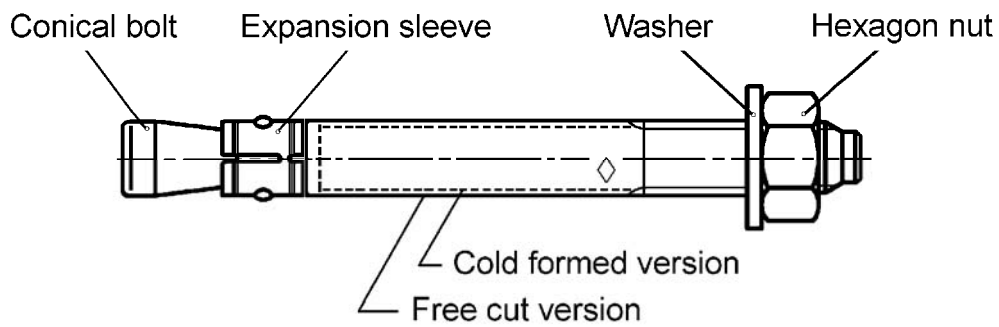

TOX Wedge Anchor B/B-U

Product and intended use

Annex 1

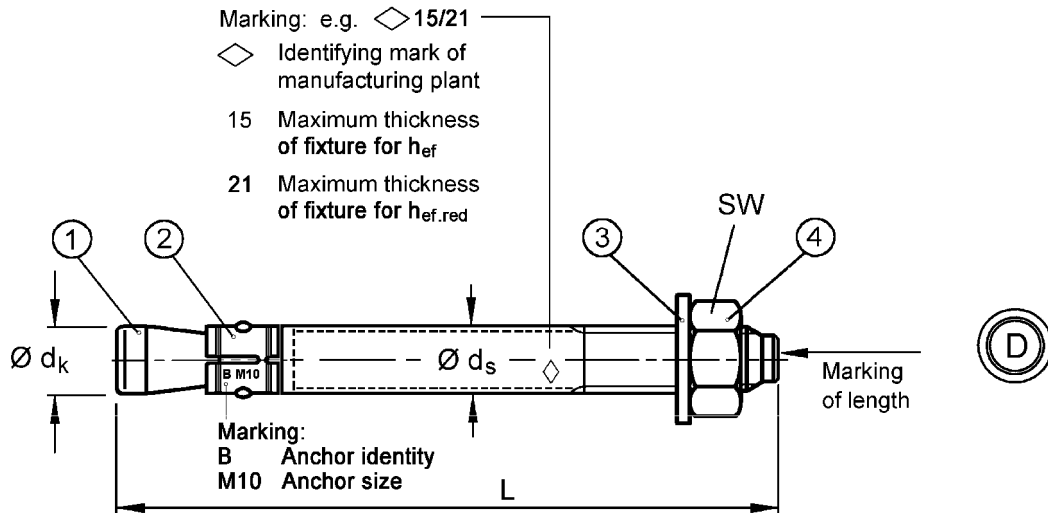

Marking of length	A	B	C	D	E	F	G	H	I	J	K	L	M
Length of anchor min \geq	38,1	50,8	63,5	76,2	88,9	101,6	114,3	127,0	139,7	152,4	165,1	177,8	190,5
Length of anchor max $<$	50,8	63,5	76,2	88,9	101,6	114,3	127,0	139,7	152,4	165,1	177,8	190,5	203,2

Marking of length	N	O	P	Q	R	S	T	U	V	W	X	Y	Z
Length of anchor min \geq	203,2	215,9	228,6	241,3	254,0	279,4	304,8	330,2	355,6	381,0	406,4	431,8	457,2
Length of anchor max $<$	215,9	228,6	241,3	254,0	279,4	304,8	330,2	355,6	381,0	406,4	431,8	457,2	483,0

Dimensions in mm

Table 1: Dimensions, zinc plated

Anchor size	$\varnothing d_k$	$\varnothing d_s$	Anchor length L		Wrench size [SW]
			Standard anchorage depth	Reduced anchorage depth	
Steel zinc plated and hot-dip galvanised					
M6	6	6 / 5,3 ¹⁾	$t_{fix} + 57,4$	$t_{fix, hef, red} + 47,4$	10
M8	8	8 / 7,1 ¹⁾	$t_{fix} + 66,4$	$t_{fix, hef, red} + 57,4$	13
M10	10	10 / 8,9 ¹⁾	$t_{fix} + 74,0$	$t_{fix, hef, red} + 68,0$	17
M12	12	12 / 10,7 ¹⁾	$t_{fix} + 97,3$	$t_{fix, hef, red} + 82,3$	19
M16	16	16 / 14,5 ¹⁾	$t_{fix} + 121,0$	$t_{fix, hef, red} + 103,0$	24
M20	20	20 / 18,2 ¹⁾	$t_{fix} + 142,7$	$t_{fix, hef, red} + 120,7$	30

¹⁾ cold formed version

Table 2: Material properties, zinc plated

Part	Designation	Material	
		Steel, electroplated $\geq 5 \mu\text{m}$ acc. to EN ISO 4042	Steel, hot-dip galvanised $\geq 40 \mu\text{m}$, acc. to EN ISO 1461
1	Conical bolt	Cold formed or machined steel	Cold formed or machined steel
2	Expansion sleeve	Steel, acc. to EN 10088, material No. 1.4301 or 1.4303	Steel, acc. to EN 10088, material No. 1.4301 or 1.4303
3	Washer	Steel	Steel
4	Hexagon nut	Property class 8 acc. to EN ISO 898-2	Property class 8 acc. to EN ISO 898-2

TOX Wedge Anchor B/B-U

**Dimensions,
Material properties, zinc plated**

Annex 2

Table 3: Installation data, zinc plated

Anchor size			M6	M8	M10	M12	M16	M20
Nominal drill hole diameter	$d_0 =$	[mm]	6	8	10	12	16	20
Cutting diameter of drill bit	$d_{cut} \leq$	[mm]	6,40	8,45	10,45	12,5	16,5	20,55
Installation torque (Wedge Anchor B/B-U electroplated)	$T_{inst} =$	[Nm]	8	15	30	50	100	200
Installation torque (Wedge Anchor B/B-U hot-dip galvanised)	$T_{inst} =$	[Nm]	-	15	30	40	90	120
Diameter of clearance hole in the fixture	$d_f \leq$	[mm]	7	9	12	14	18	22
Standard anchorage depth								
Depth of drill hole	$h_1 \geq$	[mm]	55	65	70	90	110	130
Embedment depth	$h_{nom} \geq$	[mm]	49	56	62	82	102	121
Effective anchorage depth	$h_{ef} \geq$	[mm]	40	44	48	65	82	100
Reduced anchorage depth								
Depth of drill hole	$h_{1,red} \geq$	[mm]	45	55	65	75	95	110
Embedment depth	$h_{nom,red} \geq$	[mm]	39	47	56	67	84	99
Effective anchorage depth	$h_{ef,red} \geq$	[mm]	30	35	42	50	64	78

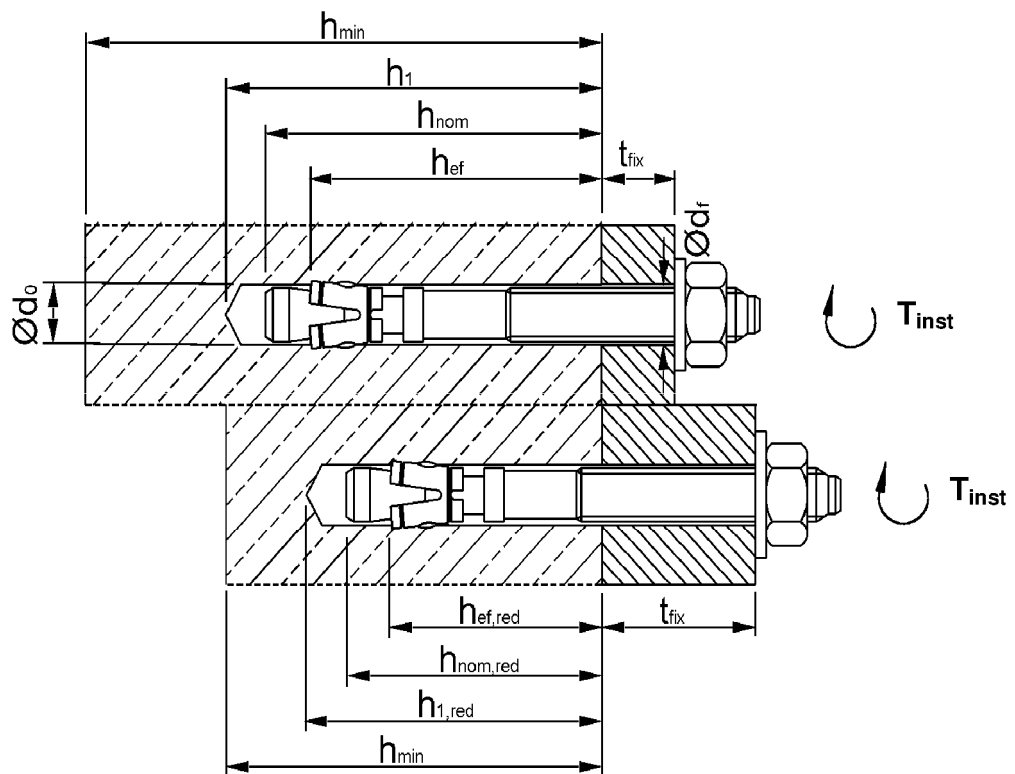

TOX Wedge Anchor B/B-U

Installation data, zinc plated

Annex 3

Installation instructions

	<p>Drill hole perpendicular to concrete surface.</p>
	<p>Blow out dust.</p>
	<p>Check position of nut.</p>
	<p>Drive in anchor.</p>
	<p>Apply installation torque T_{inst} by using torque wrench.</p>

Table 4: Minimum thickness of concrete member, minimum spacing and minimum edge distances, zinc plated

Anchor size			M6	M8	M10	M12	M16	M20
Standard anchorage depth h_{ef}								
Minimum member thickness	h_{min}	[mm]	100	100	100	130	170	200
Minimum spacing	s_{min}	[mm]	35	40	55	75	90	105
Minimum edge distance	c_{min}	[mm]	40	45	65	90	105	125
Reduced anchorage depth $h_{ef,red}$								
Minimum member thickness	h_{min}	[mm]	80	80	100	100	130	160
Minimum spacing	s_{min}	[mm]	35	40	55	100	100	140
Minimum edge distance	c_{min}	[mm]	40	45	65	100	100	140

TOX Wedge Anchor B/B-U

Installation instructions,
Minimum member thickness, minimum spacing
and minimum edge distance, zinc plated

Annex 4

Table 5: Characteristic values for tension loads, ETAG 001, Annex C, zinc plated

Anchor size			M6	M8	M10	M12	M16	M20
Steel failure								
Characteristic resistance	$N_{Rk,s}$	[kN]	8,7	15,3	26	35	65	107
Partial safety factor	γ_{Ms}	[-]	1,5				1,6	
Pull-out for standard anchorage depth h_{ef}								
Characteristic resistance in non-cracked concrete C20/25	$N_{Rk,p}$	[kN]	9	12	16	1)	1)	1)
Pull-out for reduced anchorage depth $h_{ef,red}$								
Characteristic resistance in non-cracked concrete C20/25	$N_{Rk,p}$	[kN]	6 ²⁾	1)2)	1)	1)	1)	1)
Increasing factors for $N_{Rk,p}$	ψ_C	C30/37	1,22					
		C40/50	1,41					
		C50/60	1,55					
Concrete cone failure for standard anchorage depth h_{ef}								
Effective anchorage depth	$h_{ef} \geq$	[mm]	40	44	48	65	82	100
Spacing	$s_{cr,N}$	[mm]	3 h_{ef}					
Edge distance	$c_{cr,N}$	[mm]	1,5 h_{ef}					
Concrete cone failure for reduced anchorage depth $h_{ef,red}$								
Effective anchorage depth	$h_{ef,red} \geq$	[mm]	30 ²⁾	35 ²⁾	42	50	64	78
Spacing	$s_{cr,N}$	[mm]	3 $h_{ef,red}$					
Edge distance	$c_{cr,N}$	[mm]	1,5 $h_{ef,red}$					
Splitting for standard anchorage depth h_{ef}								
Spacing	$s_{cr,sp}$	[mm]	160	220	240	330	410	500
Edge distance	$c_{cr,sp}$	[mm]	80	110	120	165	205	250
Splitting for reduced anchorage depth $h_{ef,red}$								
Spacing	$s_{cr,sp}$	[mm]	180	210	230	240	320	400
Edge distance	$c_{cr,sp}$	[mm]	90	105	115	120	160	200
Partial safety factor	$\gamma_{Mp} = \gamma_{Mc} = \gamma_{Msp}$	[-]	1,5					

1) Pull-out failure is not decisive

2) Use restricted to anchorages of indeterminate structural components

Table 6: Displacements under tension loads, zinc plated

Anchor size			M6	M8	M10	M12	M16	M20
Standard anchorage depth								
Tension load	N	[kN]	4,3	5,8	7,6	11,9	16,7	23,8
Displacement	δ_{N0}	[mm]	0,4	0,5				
	$\delta_{N\infty}$	[mm]	0,7	2,3				
Reduced anchorage depth								
Tension load	N	[kN]	2,9	5,0	6,5	8,5	12,3	16,6
Displacement	δ_{N0}	[mm]	0,3	0,4				
	$\delta_{N\infty}$	[mm]	0,6	1,8				

TOX Wedge Anchor B/B-U

**Characteristic values for tension loads,
ETAG 001, Annex C,
Displacements under tension loads, zinc plated**

Annex 5

Table 7: Characteristic values for shear loads, ETAG 001, Annex C, zinc plated

Anchor size			M6	M8	M10	M12	M16	M20
Steel failure without lever arm								
Characteristic resistance	$V_{Rk,s}$	[kN]	5	11	17	25	44	69
Partial safety factor	γ_{Ms}	[-]	1,25				1,33	
Steel failure with lever arm								
Characteristic resistance	$M_{Rk,s}^0$	[Nm]	9	23	45	78	186	363
Partial safety factor	γ_{Ms}	[-]	1,25				1,33	
Concrete pryout failure for standard anchorage depth h_{ef}								
Factor in equation (5.6) of ETAG 001, Annex C, 5.2.3.3	k	[-]	1,0	1,0	1,0	2,0	2,0	2,0
Concrete pryout failure for reduced anchorage depth $h_{ef,red}$								
Factor in equation (5.6) of ETAG 001, Annex C, 5.2.3.3	k	[-]	1,0 ¹⁾	1,0 ¹⁾	1,0	1,0	2,0	2,0
Partial safety factor	γ_{Mcp}	[-]	1,5					
Concrete edge failure for standard anchorage depth h_{ef}								
Effective length of anchor in shear loading	l_f	[mm]	40	44	48	65	82	100
Concrete edge failure for standard anchorage depth $h_{ef,red}$								
Effective length of anchor in shear loading	l_f	[mm]	30 ¹⁾	35 ¹⁾	42	50	64	78
Diameter of anchor	d_{nom}	[mm]	6	8	10	12	16	20
Partial safety factor	γ_{Mc}	[-]	1,5					

¹⁾ Use restricted to anchorages of indeterminate structural components

Table 8: Displacements under shear loads, zinc plated

Anchor size			M6	M8	M10	M12	M16	M20
Shear load	V	[kN]	2,9	6,3	9,7	14,3	23,6	37,0
Displacements	δ_{V0}	[mm]	1,2	1,5	1,6	2,6	3,1	4,4
	$\delta_{V\infty}$	[mm]	2,4	2,2	2,4	3,9	4,6	6,6

TOX Wedge Anchor B/B-U

**Characteristic values for shear loads,
ETAG 001, Annex C,
Displacements under shear loads, zinc plated**

Annex 6

Table 9: Characteristic values for tension loads, CEN/TS 1992-4, zinc plated

Anchor size			M6	M8	M10	M12	M16	M20
Steel failure								
Characteristic resistance	$N_{Rk,s}$	[kN]	8,7	15,3	26	35	65	107
Partial safety factor	γ_{Ms}	[-]	1,5			1,6		
Pull-out for standard anchorage depth h_{ef}								
Characteristic resistance in non-cracked concrete C20/25	$N_{Rk,p}$	[kN]	9	12	16	1)	1)	1)
Pull-out for reduced anchorage depth $h_{ef,red}$								
Characteristic resistance in non-cracked concrete C20/25	$N_{Rk,p}$	[kN]	6 ²⁾	1)2)	1)	1)	1)	1)
Increasing factors for $N_{Rk,p}$	ψ_C	C30/37	[-]			1,22		
		C40/50	[-]			1,41		
		C50/60	[-]			1,55		
Concrete cone failure for standard anchorage depth h_{ef}								
Effective anchorage depth	$h_{ef} \geq$	[mm]	40	44	48	65	82	100
Factor for uncracked concrete	k_{ucr}	[-]	10,1					
Spacing	$s_{cr,N}$	[mm]	3 h_{ef}					
Edge distance	$c_{cr,N}$	[mm]	1,5 h_{ef}					
Concrete cone failure for reduced anchorage depth $h_{ef,red}$								
Effective anchorage depth	$h_{ef,red} \geq$	[mm]	30 ²⁾	35 ²⁾	42	50	64	78
Factor for uncracked concrete	k_{ucr}	[-]	10,1					
Spacing	$s_{cr,N}$	[mm]	3 $h_{ef,red}$					
Edge distance	$c_{cr,N}$	[mm]	1,5 $h_{ef,red}$					
Splitting for standard anchorage depth h_{ef}								
Spacing	$s_{cr,sp}$	[mm]	160	220	240	330	410	500
Edge distance	$c_{cr,sp}$	[mm]	80	110	120	165	205	250
Splitting for reduced anchorage depth $h_{ef,red}$								
Spacing	$s_{cr,sp}$	[mm]	180	210	230	240	320	400
Edge distance	$c_{cr,sp}$	[mm]	90	105	115	120	160	200
Partial safety factor	$\gamma_{Mp} = \gamma_{Mc} = \gamma_{Msp}$	[-]	1,5					

1) Pull-out failure is not decisive

2) Use restricted to anchorages of indeterminate structural components

Table 10: Displacements under tension loads, zinc plated

Anchor size			M6	M8	M10	M12	M16	M20
Standard anchorage depth								
Tension load	N	[kN]	4,3	5,8	7,6	11,9	16,7	23,8
Displacement	δ_{N0}	[mm]	0,4	0,5				
	$\delta_{N\infty}$	[mm]	0,7	2,3				
Reduced anchorage depth								
Tension load	N	[kN]	2,9	5,0	6,5	8,5	12,3	16,6
Displacement	δ_{N0}	[mm]	0,3	0,4				
	$\delta_{N\infty}$	[mm]	0,6	1,8				

TOX Wedge Anchor B/B-U

**Characteristic values for tension loads,
CEN/TS 1992-4,
Displacements under tension loads, zinc plated**

Annex 7

Table 11: Characteristic values for shear loads, CEN/TS 1992-4, zinc plated

Anchor size			M6	M8	M10	M12	M16	M20
Steel failure without lever arm								
Characteristic resistance	$V_{Rk,s}$	[kN]	5	11	17	25	44	69
Factor of ductility	k_2		1,0					
Partial safety factor	γ_{Ms}	[-]	1,25				1,33	
Steel failure with lever arm								
Characteristic resistance	$M^0_{Rk,s}$	[Nm]	9	23	45	78	186	363
Partial safety factor	γ_{Ms}	[-]	1,25				1,33	
Concrete pryout failure for standard anchorage depth h_{ef}								
Factor in equation (16) CEN/TS 1992-4-4, 6.2.2.3	k_3	[-]	1,0	1,0	1,0	2,0	2,0	2,0
Concrete pryout failure for reduced anchorage depth $h_{ef,red}$								
Factor in equation (16) CEN/TS 1992-4-4, 6.2.2.3	k_3	[-]	1,0 ¹⁾	1,0 ¹⁾	1,0	1,0	2,0	2,0
Partial safety factor	γ_{Mcp}	[-]	1,5					
Concrete edge failure for standard anchorage depth h_{ef}								
Effective length of anchor in shear loading	l_f	[mm]	40	44	48	65	82	100
Concrete edge failure for standard anchorage depth $h_{ef,red}$								
Effective length of anchor in shear loading	l_f	[mm]	30 ¹⁾	35 ¹⁾	42	50	64	78
Diameter of anchor	d_{nom}	[mm]	6	8	10	12	16	20
Partial safety factor	γ_{Mc}	[-]	1,5					

¹⁾ Use restricted to anchorages of indeterminate structural components

Table 12: Displacements under shear loads, zinc plated

Anchor size			M6	M8	M10	M12	M16	M20
Shear load	V	[kN]	2,9	6,3	9,7	14,3	23,6	37,0
Displacements	δ_{v0}	[mm]	1,2	1,5	1,6	2,6	3,1	4,4
	$\delta_{v\infty}$	[mm]	2,4	2,2	2,4	3,9	4,6	6,6

TOX Wedge Anchor B/B-U

**Characteristic values for shear loads,
CEN/TS 1992-4,
Displacements under shear loads, zinc plated**

Annex 8

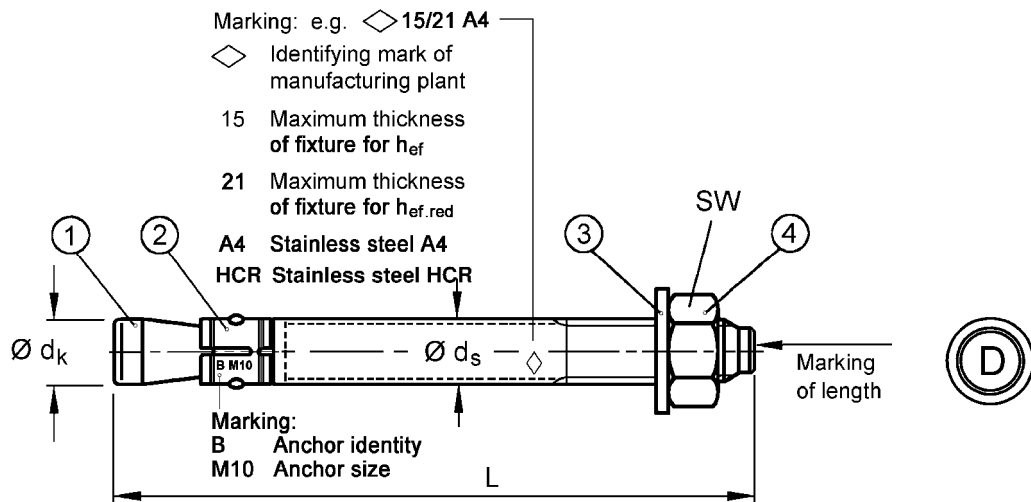

Marking of length	A	B	C	D	E	F	G	H	I	J	K	L	M
Length of anchor min \geq	38,1	50,8	63,5	76,2	88,9	101,6	114,3	127,0	139,7	152,4	165,1	177,8	190,5
Length of anchor max $<$	50,8	63,5	76,2	88,9	101,6	114,3	127,0	139,7	152,4	165,1	177,8	190,5	203,2

Marking of length	N	O	P	Q	R	S	T	U	V	W	X	Y	Z
Length of anchor min \geq	203,2	215,9	228,6	241,3	254,0	279,4	304,8	330,2	355,6	381,0	406,4	431,8	457,2
Length of anchor max $<$	215,9	228,6	241,3	254,0	279,4	304,8	330,2	355,6	381,0	406,4	431,8	457,2	483,0

Dimensions in mm

Table 13: Dimensions, stainless steel A4/HCR

Anchor size	$\varnothing d_k$	$\varnothing d_s$	Anchor length L		SW
			Standard anchorage depth	Reduced anchorage depth	
Stainless steel A4/HCR					
M6	6	6 / 5,3 ¹⁾	$t_{fix} + 57,4$	$t_{fix\ hf,red} + 47,4$	10
M8	8	8 / 7,1 ¹⁾	$t_{fix} + 66,4$	$t_{fix\ hf,red} + 57,4$	13
M10	10	10 / 8,9 ¹⁾	$t_{fix} + 74,0$	$t_{fix\ hf,red} + 68,0$	17
M12	12	12 / 10,7 ¹⁾	$t_{fix} + 96,5$	$t_{fix\ hf,red} + 81,5$	19
M16	16	16 / 14,5 ¹⁾	$t_{fix} + 117,8$	$t_{fix\ hf,red} + 101,8$	24
M20	19,7	19,7 / 18,2 ¹⁾	$t_{fix} + 142,7$	$t_{fix\ hf,red} + 120,7$	30

¹⁾ cold formed version

Table 14: Designations and Materials, stainless steel A4/HCR

Part	Designation	Stainless steel A4	High corrosion resistant steel HCR
1	Conical bolt	Stainless steel 1.4401, 1.4404, 1.4571, 1.4578, 1.4362, EN 10088, coated	High corrosion resistant steel 1.4529, 1.4565, EN 10088, coated
2	Expansion sleeve	Stainless steel 1.4401, 1.4571, 1.4362, EN 10088	
3	Washer acc. to EN ISO 7089, or EN ISO 7093, or EN ISO 7094	Stainless steel 1.4401, 1.4571, 1.4362, EN 10088	High corrosion resistant steel 1.4529, 1.4565, EN 10088
4	Hexagon nut DIN 934	ISO 3506, A4-70, stainless steel 1.4401, 1.4571, 1.4362, EN 10088, coated	ISO 3506, strength class 70, high corrosion resistant steel 1.4529, 1.4565, EN 10088, coated

TOX Wedge Anchor B/B-U

Dimensions,
Designations and materials of anchor, stainless steel A4/HCR

Annex 9

Table 15: Installation data, stainless steel A4/HCR

Anchor size		M6	M8	M10	M12	M16	M20
Nominal drill hole diameter	$d_0 =$ [mm]	6	8	10	12	16	20
Cutting diameter of drill bit	$d_{cut} \leq$ [mm]	6,40	8,45	10,45	12,5	16,5	20,55
Installation torque	$T_{inst} =$ [Nm]	6	15	25	50	100	160
Diameter of clearance hole in the fixture	$d_f \leq$ [mm]	7	9	12	14	18	22
Standard anchorage depth							
Depth of drill hole	$h_1 \geq$ [mm]	55	65	70	90	110	130
Embedment depth	$h_{nom} \geq$ [mm]	49	56	62	81	99	121
Effective anchorage depth	$h_{ef} \geq$ [mm]	40	44	48	65	80	100
Reduced anchorage depth							
Depth of drill hole	$h_{1,red} \geq$ [mm]	45	55	65	75	95	110
Embedment depth	$h_{nom,red} \geq$ [mm]	39	47	56	66	83	99
Effective anchorage depth	$h_{ef,red} \geq$ [mm]	30	35	42	50	64	78

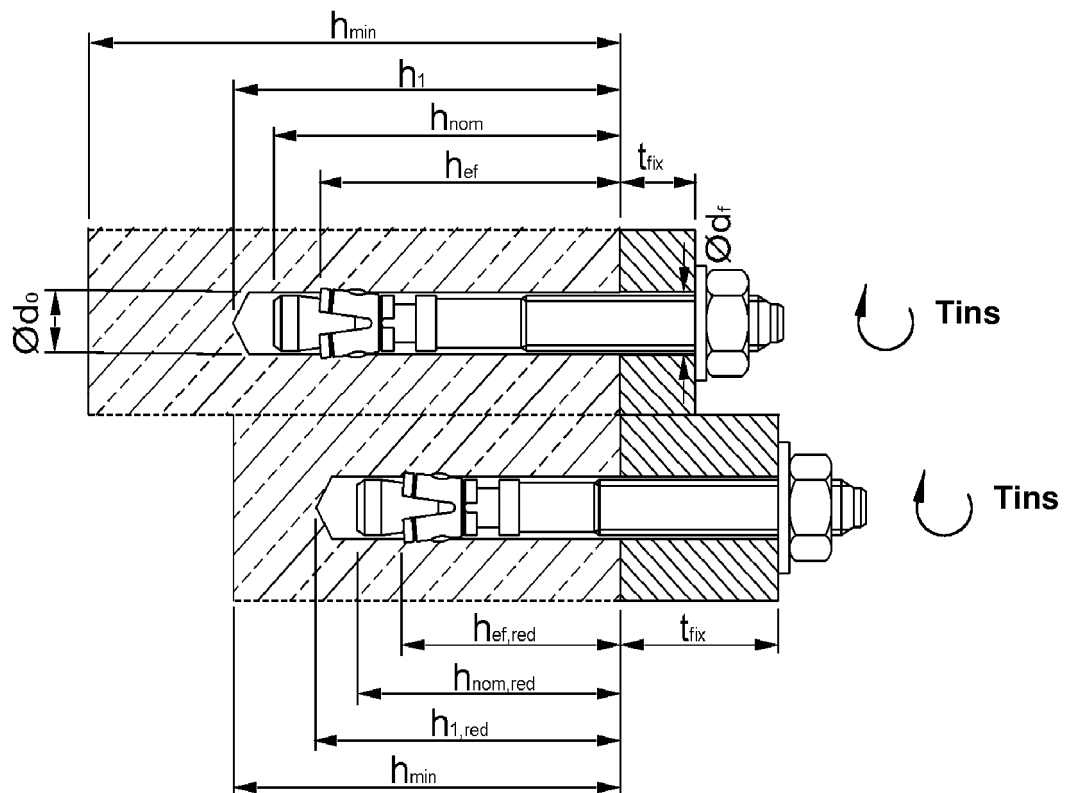

TOX Wedge Anchor B/B-U

Installation data, stainless steel A4/HCR

Annex 10

Installation instructions

	<p>Drill hole perpendicular to concrete surface.</p>
	<p>Blow out dust.</p>
	<p>Check position of nut.</p>
	<p>Drive in anchor.</p>
	<p>Apply installation torque T_{inst} by using torque wrench.</p>

Table 16: Minimum thickness of concrete member, minimum spacing and minimum edge distance, stainless steel A4/HCR

Anchor size			M6	M8	M10	M12	M16	M20
Standard anchorage depth h_{ef}								
Minimum member thickness	h_{min}	[mm]	100	100	100	130	160	200
Minimum spacing	s_{min}	[mm]	35	35	45	60	80	100
	for $c \geq$	[mm]	40	65	70	100	120	150
Minimum edge distance	c_{min}	[mm]	35	45	55	70	80	100
	for $s \geq$	[mm]	60	110	80	100	140	180
Reduced anchorage depth $h_{ef,red}$								
Minimum member thickness	h_{min}	[mm]	80	80	100	100	130	160
Minimum spacing	s_{min}	[mm]	35	60	55	100	110	140
Minimum edge distance	c_{min}	[mm]	40	60	65	100	110	140

TOX Wedge Anchor B/B-U

**Installation instructions,
Minimum thickness of member, minimum spacing and edge distance,
stainless steel A4/HCR**

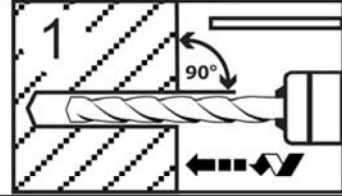
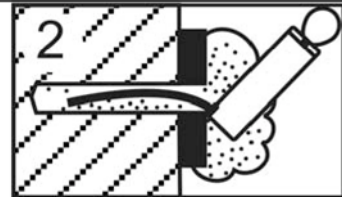
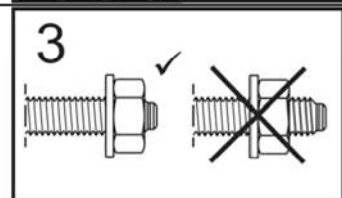
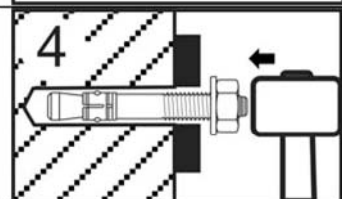
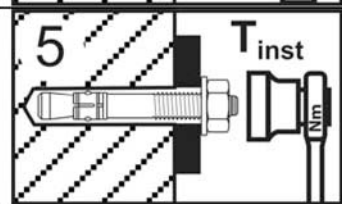
Annex 11

Table 17: Characteristic values for tension loads, ETAG 001, Annex C, stainless steel A4/HCR

Anchor size		M6	M8	M10	M12	M16	M20		
Steel failure									
Characteristic resistance	$N_{RK,s}$	[kN]	10	18	30	44	88	134	
Partial safety factor	γ_{Ms}	[-]	1,50				1,68		
Pull-out for standard anchorage depth h_{ef}									
Characteristic resistance in non-cracked concrete C20/25	$N_{RK,p}$	[kN]	7,5	12	16	25	1)	1)	
Pull-out for reduced anchorage depth $h_{ef,red}$									
Characteristic resistance in non-cracked concrete C20/25	$N_{RK,p}$	[kN]	6 ²⁾	9 ²⁾	12	1)	1)	1)	
Splitting for standard anchorage depth h_{ef}									
The higher one of the decisive resistances of Case 1 and Case 2 is applicable.									
Case 1									
Characteristic resistance in non-cracked concrete C20/25	$N_{RK,sp}$ ³⁾	[kN]	6	9	12	20	30	40	
Respective spacing	$s_{cr,sp}$	[mm]	3 h_{ef}						
Respective edge distance	$c_{cr,sp}$	[mm]	1,5 h_{ef}						
Case 2									
Characteristic resistance in non-cracked concrete C20/25	$N_{RK,sp}$	[kN]	7,5 ³⁾	12 ³⁾	16 ³⁾	25 ³⁾	1)	1)	
Respective spacing	$s_{cr,sp}$	[mm]	160	220	240	340	410	560	
Respective edge distance	$c_{cr,sp}$	[mm]	80	110	120	170	205	280	
Splitting for reduced anchorage depth $h_{ef,red}$									
Characteristic resistance in non-cracked concrete C20/25	$N_{RK,sp}$	[kN]	6 ²⁾	9 ²⁾	12	1)	1)	1)	
Respective spacing	$s_{cr,sp}$	[mm]	180	210	230	300	320	400	
Respective edge distance	$c_{cr,sp}$	[mm]	90	105	115	150	160	200	
Increasing factors for $N_{RK,p}$	ψ_C	C30/37	[-]	1,22					
		C40/50	[-]	1,41					
		C50/60	[-]	1,55					
Concrete cone failure for standard anchorage depth h_{ef}									
Effective anchoring depth	h_{ef}	[mm]	40	44	48	65	80	100	
Spacing	$s_{cr,N}$	[mm]	3 h_{ef}						
Edge distance	$c_{cr,N}$	[mm]	1,5 h_{ef}						
Concrete cone failure for reduced anchorage depth $h_{ef,red}$									
Effective anchoring depth	$h_{ef,red}$	[mm]	30 ²⁾	35 ²⁾	42	50	64	78	
Spacing	$s_{cr,N}$	[mm]	3 h_{ef}						
Edge distance	$c_{cr,N}$	[mm]	1,5 h_{ef}						
Partial safety factor	$\gamma_{Mp} = \gamma_{Msp} = \gamma_{Mc}$	[-]	1,5						

¹⁾ Pull-out failure is not decisive.

²⁾ Use restricted to anchorages of indeterminate structural components

³⁾ For the proof against splitting failure according to ETAG 001, Annex C, $N_{RK,c}$ in equation (5.3) has to be replaced by $N_{RK,sp}$.

TOX Wedge Anchor B/B-U

Characteristic values for tension loads, ETAG 001, Annex C, stainless steel A4/HCR

Annex 12

Table 18: Displacements under tension loads, stainless steel A4/HCR

Anchor size			M6	M8	M10	M12	M16	M20
Standard anchorage depth								
Tension load	N	[kN]	3,6	5,7	7,6	11,9	17,2	24,0
Displacement	δ_{N0}	[mm]	0,7	0,9	0,5	0,6	0,9	2,1
	$\delta_{N\infty}$	[mm]	1,8					
Reduced anchorage depth								
Tension load	N	[kN]	2,9	4,3	5,7	8,5	12,3	16,6
Displacement	δ_{N0}	[mm]	0,4	0,7	0,4	0,4	0,6	1,5
	$\delta_{N\infty}$	[mm]	1,3					

Table 19: Characteristic values for shear loads, ETAG 001, Annex C, stainless steel A4/HCR

Anchor Size			M6	M8	M10	M12	M16	M20	
Steel failure without lever arm									
Characteristic resistance	$V_{Rk,s}$	[kN]	7	12	19	27	50	86	
Partial safety factor	γ_{Ms}	[-]	1,25						1,4
Steel failure with lever arm									
Characteristic bending moment	$M_{Rk,s}^0$	[Nm]	10	24	49	85	199	454	
Partial safety factor	γ_{Ms}	[-]	1,25						1,4
Concrete pryout failure for standard anchorage depth h_{ef}									
Factor in equation (5.6) ETAG 001, Annex C, 5.2.3.3	k	[-]	1,0	1,0	1,0	2,0	2,0	2,0	
Concrete pryout failure for reduced anchorage depth $h_{ef,red}$									
Factor in equation (5.6) ETAG 001, Annex C, 5.2.3.3	k	[-]	1,0 ¹⁾	1,0 ¹⁾	1,0	1,0	2,0	2,0	
Partial safety factor	γ_{Mcp}	[-]	1,5						
Concrete edge failure for standard anchorage depth h_{ef}									
Effective length of anchor in shear loading	l_f	[mm]	40	44	48	65	80	100	
Concrete edge failure for reduced anchorage depth $h_{ef,red}$									
Effective length of anchor in shear loading	l_f	[mm]	30 ¹⁾	35 ¹⁾	42	50	64	78	
Outside diameter of anchor	d_{nom}	[mm]	6	8	10	12	16	20	
Partial safety factor	γ_{Mc}	[-]	1,5						

¹⁾ Use restricted to anchorages of indeterminate structural components

Table 20: Displacements under shear loads, stainless steel A4/HCR

Anchor Size			M6	M8	M10	M12	M16	M20
Shear load	V	[kN]	4,0	6,9	10,9	15,4	28,6	43,7
Displacements	δ_{V0}	[mm]	1,1	2,0	1,2	2,0	2,2	2,1
	$\delta_{V\infty}$	[mm]	1,7	3,0	1,8	3,0	3,3	3,2

TOX Wedge Anchor B/B-U

**Characteristic values for shear loads, ETAG 001, Annex C,
Displacements under tension and shear loads,
stainless steel A4/HCR**

Annex 13

Table 21: Characteristic values for tension loads, CEN/TS 1992-4, stainless steel A4/HCR

Anchor size			M6	M8	M10	M12	M16	M20
Steel failure								
Characteristic resistance	$N_{Rk,s}$	[kN]	10	18	30	44	88	134
Partial safety factor	γ_{Ms}	[-]	1,50					1,68
Pull-out for standard anchorage depth h_{ef}								
Characteristic resistance in non-cracked concrete C20/25	$N_{Rk,p}$	[kN]	7,5	12	16	25	1)	1)
Pull-out for reduced anchorage depth $h_{ef,red}$								
Characteristic resistance in non-cracked concrete C20/25	$N_{Rk,p}$	[kN]	6 ²⁾	9 ²⁾	12	1)	1)	1)
Splitting for standard anchorage depth h_{ef}								
The higher one of the decisive resistances of Case 1 and Case 2 is applicable.								
Case 1								
Characteristic resistance in non-cracked concrete C20/25	$N_{Rk,sp}$ ³⁾	[kN]	6	9	12	20	30	40
Respective spacing	$s_{cr,sp}$	[mm]	3 h_{ef}					
Respective edge distance	$c_{cr,sp}$	[mm]	1,5 h_{ef}					
Case 2								
Characteristic resistance in non-cracked concrete C20/25	$N_{Rk,sp}$	[kN]	7,5 ³⁾	12 ³⁾	16 ³⁾	25 ³⁾	1)	1)
Respective spacing	$s_{cr,sp}$	[mm]	160	220	240	340	410	560
Respective edge distance	$c_{cr,sp}$	[mm]	80	110	120	170	205	280
Splitting for reduced anchorage depth $h_{ef,red}$								
Characteristic resistance in non-cracked concrete C20/25	$N_{Rk,sp}$	[kN]	6 ²⁾	9 ²⁾	12	1)	1)	1)
Respective spacing	$s_{cr,sp}$	[mm]	180	210	230	300	320	400
Respective edge distance	$c_{cr,sp}$	[mm]	90	105	115	150	160	200
Increasing factors for $N_{Rk,p}$	C30/37	[-]	1,22					
	ψ_C C40/50	[-]	1,41					
	C50/60	[-]	1,55					
Concrete cone failure for standard anchorage depth h_{ef}								
Effective anchoring depth	h_{ef}	[mm]	40	44	48	65	80	100
Factor for non-cracked concrete	k_{ucr}	[-]	10,1					
Spacing	$s_{cr,N}$	[mm]	3 h_{ef}					
Edge distance	$c_{cr,N}$	[mm]	1,5 h_{ef}					
Concrete cone failure for reduced anchorage depth $h_{ef,red}$								
Effective anchoring depth	$h_{ef,red}$	[mm]	30 ²⁾	35 ²⁾	42	50	64	78
Factor for non-cracked concrete	k_{ucr}	[-]	10,1					
Spacing	$s_{cr,N}$	[mm]	3 h_{ef}					
Edge distance	$c_{cr,N}$	[mm]	1,5 h_{ef}					
Partial safety factor	$\gamma_{Mp} = \gamma_{Msp} = \gamma_{Mc}$	[-]	1,5					

¹⁾ Pull-out failure is not decisive.

²⁾ Use restricted to anchorages of indeterminate structural components

³⁾ For the proof against splitting failure according CEN/TS 1992-4-4, $N_{Rk,c}^0$ in equation (12) has to be replaced by $N_{Rk,sp}$.

TOX Wedge Anchor B/B-U

**Characteristic values for tension loads,
CEN/TS 1992-4, stainless steel A4/HCR**

Annex 14

Table 22: Displacements under tension loads, stainless steel A4/HCR

Anchor size			M6	M8	M10	M12	M16	M20
Standard anchorage depth								
Tension load	N	[kN]	3,6	5,7	7,6	11,9	17,2	24,0
Displacement	δ_{N0}	[mm]	0,7	0,9	0,5	0,6	0,9	2,1
	$\delta_{N\infty}$	[mm]	1,8					
Reduced anchorage depth								
Tension load	N	[kN]	2,9	4,3	5,7	8,5	12,3	16,6
Displacement	δ_{N0}	[mm]	0,4	0,7	0,4	0,4	0,6	1,5
	$\delta_{N\infty}$	[mm]	1,3					

Table 23: Characteristic values for shear loads, CEN/TS 1992-4, stainless steel A4/HCR

Anchor Size			M6	M8	M10	M12	M16	M20
Steel failure without lever arm								
Characteristic resistance	$V_{Rk,s}$	[kN]	7	12	19	27	50	86
Ductility factor	k_2	[-]	1,0					
Partial safety factor	γ_{Ms}	[-]	1,25					
Steel failure with lever arm								
Characteristic bending moment	$M^0_{Rk,s}$	[Nm]	10	24	49	85	199	454
Partial safety factor	γ_{Ms}	[-]	1,25					
Concrete pryout failure for standard anchorage depth h_{ef}								
Factor in equation (16) CEN/TS 1992-4-4, 6.2.2.3	k_3	[-]	1,0	1,0	1,0	2,0	2,0	2,0
Concrete pryout failure for reduced anchorage depth $h_{ef,red}$								
Factor in equation (16) CEN/TS 1992-4-4, 6.2.2.3	k_3	[-]	1,0 ¹⁾	1,0 ¹⁾	1,0	1,0	2,0	2,0
Partial safety factor	γ_{Mcp}	[-]	1,5					
Concrete edge failure for standard anchorage depth h_{ef}								
Effective length of anchor in shear loading	l_f	[mm]	40	44	48	65	80	100
Concrete edge failure for reduced anchorage depth $h_{ef,red}$								
Effective length of anchor in shear loading	l_f	[mm]	30 ¹⁾	35 ¹⁾	42	50	64	78
Outside diameter of anchor	d_{nom}	[mm]	6	8	10	12	16	20
Partial safety factor	γ_{Mc}	[-]	1,5					

¹⁾ Use restricted to anchorages of indeterminate structural components

Table 24: Displacements under shear loads, stainless steel A4/HCR

Anchor Size			M6	M8	M10	M12	M16	M20
Shear load	V	[kN]	4,0	6,9	10,9	15,4	28,6	43,7
Displacements	δ_{V0}	[mm]	1,1	2,0	1,2	2,0	2,2	2,1
	$\delta_{V\infty}$	[mm]	1,7	3,0	1,8	3,0	3,3	3,2

TOX Wedge Anchor B/B-U

**Characteristic values for shear loads, CEN/TS 1992-4,
Displacements under tension and shear loads,
stainless steel A4/HCR**

Annex 15