



European Technical Approval ETA-11/0191

English translation prepared by DIBt - Original version in German language

Handelsbezeichnung
Trade name

TDBL-T-8,6xL und TDBL-T-10,6xL
TDBL-T-8,6xL and TDBL-T-10,6xL

Zulassungsinhaber
Holder of approval

SFS intec AG
FasteningSystems
Rosenbergsaustraße 10
9435 HEERBRUGG
SCHWEIZ

Zulassungsgegenstand
und Verwendungszweck
*Generic type and use
of construction product*

Gewindefurchende Schrauben TDBL-T-8,6xL und TDBL-T-10,6xL
Self tapping screws TDBL-T-8,6xL and TDBL-T-10,6xL

Geltungsdauer:
Validity: vom
from
bis
to

17 June 2013
17 June 2018

Herstellwerk
Manufacturing plant

SFS intec AG
Heerbrugg
Switzerland

Diese Zulassung umfasst
This Approval contains

25 Seiten einschließlich 18 Anhänge
25 pages including 18 annexes

Diese Zulassung ersetzt
This Approval replaces

ETA-11/0191 mit Geltungsdauer vom 28.06.2011 bis 28.06.2016
ETA-11/0191 with validity from 28.06.2011 to 28.06.2016

I LEGAL BASES AND GENERAL CONDITIONS

- 1 This European technical approval is issued by Deutsches Institut für Bautechnik in accordance with:
 - Council Directive 89/106/EEC of 21 December 1988 on the approximation of laws, regulations and administrative provisions of Member States relating to construction products¹, modified by Council Directive 93/68/EEC² and Regulation (EC) N° 1882/2003 of the European Parliament and of the Council³;
 - *Gesetz über das In-Verkehr-Bringen von und den freien Warenverkehr mit Bauprodukten zur Umsetzung der Richtlinie 89/106/EWG des Rates vom 21. Dezember 1988 zur Angleichung der Rechts- und Verwaltungsvorschriften der Mitgliedstaaten über Bauprodukte und anderer Rechtsakte der Europäischen Gemeinschaften (Bauproduktengesetz - BauPG) vom 28. April 1998⁴, as amended by Article 2 of the law of 8 November 2011⁵;*
 - Common Procedural Rules for Requesting, Preparing and the Granting of European technical approvals set out in the Annex to Commission Decision 94/23/EC⁶.
- 2 Deutsches Institut für Bautechnik is authorized to check whether the provisions of this European technical approval are met. Checking may take place in the manufacturing plant. Nevertheless, the responsibility for the conformity of the products to the European technical approval and for their fitness for the intended use remains with the holder of the European technical approval.
- 3 This European technical approval is not to be transferred to manufacturers or agents of manufacturers other than those indicated on page 1, or manufacturing plants other than those indicated on page 1 of this European technical approval.
- 4 This European technical approval may be withdrawn by Deutsches Institut für Bautechnik, in particular pursuant to information by the Commission according to Article 5(1) of Council Directive 89/106/EEC.
- 5 Reproduction of this European technical approval including transmission by electronic means shall be in full. However, partial reproduction can be made with the written consent of Deutsches Institut für Bautechnik. In this case partial reproduction has to be designated as such. Texts and drawings of advertising brochures shall not contradict or misuse the European technical approval.
- 6 The European technical approval is issued by the approval body in its official language. This version corresponds fully to the version circulated within EOTA. Translations into other languages have to be designated as such.

¹ Official Journal of the European Communities L 40, 11 February 1989, p. 12
² Official Journal of the European Communities L 220, 30 August 1993, p. 1
³ Official Journal of the European Union L 284, 31 October 2003, p. 25
⁴ *Bundesgesetzblatt Teil I 1998*, p. 812
⁵ *Bundesgesetzblatt Teil I 2011*, p. 2178
⁶ Official Journal of the European Communities L 17, 20 January 1994, p. 34

II SPECIFIC CONDITIONS OF THE EUROPEAN TECHNICAL APPROVAL

1 Definition of the product/products and intended use

1.1 Definition of the construction product

The fastening screws TDBL-T 8,6 x L and TDBL-T 10,6 x L are self tapping screws made of case hardened carbon steel with a Cr. VI free zinc- coating. For details and dimensions see Annex 1.

Examples of connections with the fastening screws TDBL-T 8,6 x L and TDBL-T 10,6 x L are shown in Annexes 2 to 4.

The fastening screws and the corresponding connections are subject to tension and shear forces.

1.2 Intended use

The fastening screws are intended to be used for fastening steel members as purlins or sheeting to steel members, steel supporting structures or sheeting. The types of connections with sheeting are shown in Annex 5.

The component to be fastened (adjacent to the screw-head) is component I and the supporting structure is component II.

The intended use comprises indoor and outdoor applications of the fastening screws TDBL-T 8,6 x L and TDBL-T 10,6 x L up to corrosion category C3 according to EN ISO 12944-2.

The fastening screws are intended to be used for connections with predominantly static loads (e.g. wind loads, dead loads).

The provisions made in this European technical approval are based on an assumed working life of the fastening screws of 25 years. The indications given on the working life cannot be interpreted as a guarantee given by the producer, but are to be regarded only as a means for choosing the right products in relation to the expected economically reasonable working life of the works.

2 Characteristics of product and methods of verification

2.1 Characteristics of product

The fastening screws TDBL-T 8,6 x L and TDBL-T 10,6 x L shall correspond to the drawings given in Annex 1.

The characteristic material values, dimensions and tolerances of the fastening screws TDBL-T 8,6 x L and TDBL-T 10,6 x L neither indicated in this section nor in the Annexes shall correspond to the respective values laid down in the technical documentation⁷ to this European technical approval.

The characteristic values of the shear and tension resistance of the connections made with the fastening screws TDBL-T 8,6 x L and TDBL-T 10,6 x L are given in the Annexes 6 to 18 or in section 4.2.

The fastening screws TDBL-T 8,6 x L and TDBL-T 10,6 x L are considered to satisfy the requirements of performance class A1 of the characteristic reaction to fire.

⁷ The technical documentation to this European technical approval is deposited at Deutsches Institut für Bautechnik and, as far as relevant for the tasks of the approved bodies involved in the attestation of conformity procedure is handed over to the approved bodies.

2.2 Methods of verification

The assessment of the fitness of the fastening screws TDBL-T 8,6 x L and TDBL-T 10,6 x L for the intended use in relation to the Essential Requirements ER 1 (Mechanical resistance and stability), ER 2 (Safety in case of fire), ER 4 (Safety in use) and additional aspects of durability has been made in accordance with section 3.2 of the Common Procedural Rules for Requesting, Preparing and the Granting of European technical approvals set out in the Annex to Commission Decision 94/23/EC⁶.

The assessment of the resistance to fire performance is only relevant to the assembled system (fastening screws, steel members, supporting structure) which is not part of the ETA.

The fastening screws TDBL-T 8,6 x L and TDBL-T 10,6 x L are considered to satisfy the requirements of performance class A 1 of the characteristic reaction to fire, in accordance with the provisions of the EC Decision 96/603/EC (as amended) without the need for testing on the basis of its listing in that decision.

Concerning Essential Requirements No. 1 (Mechanical resistance and stability) and No. 4 (Safety in use) the following applies:

The characteristic values of resistance given in the Annexes were determined by shear and tension tests.

The formulas to calculate the design resistance are given in clause 4.2.1.

3 Evaluation and attestation of conformity and CE marking

3.1 System of attestation of conformity

According to the Decision 99/92 of the European Commission⁸ system 3 of the attestation of conformity applies.

This system of attestation of conformity is defined as follows:

System 3: Declaration of conformity of the product by the manufacturer on the basis of:

- (a) Tasks for the manufacturer:
 - (1) factory production control;
- (b) Tasks for the approved body:
 - (2) initial type-testing of the product.

Note: Approved bodies are also referred to as "notified bodies".

3.2 Responsibilities

3.2.1 Tasks for the manufacturer

3.2.1.1 Factory production control

The manufacturer shall exercise permanent internal control of production. All the elements, requirements and provisions adopted by the manufacturer shall be documented in a systematic manner in the form of written policies and procedures, including records of results performed. This production control system shall insure that the product is in conformity with this European technical approval.

The manufacturer may only use initial materials stated in the technical documentation of this European technical approval.

⁸ Official Journal of the European Communities L 80 of 18.03.1998.

The factory production control shall be in accordance with the "control plan of June 2011 relating to the European technical approval ETA-11/0191 issued on 28 June 2011" which is part of the technical documentation of this European technical approval. The control plan is laid down in the context of the factory production control system operated by the manufacturer and deposited with Deutsches Institut für Bautechnik.⁹

The results of factory production control shall be recorded and evaluated in accordance with the provisions of the control plan.

3.2.1.2 Other tasks for the manufacturer

The manufacturer shall, on the basis of a contract, involve a body which is approved for the tasks referred to in section 3.1 in the field of fastening screws in order to undertake the actions laid down in section 3.2.2. For this purpose, the control plan referred to in sections 3.2.1.1 and 3.2.2 shall be handed over by the manufacturer to the approved body involved.

The manufacturer shall make a declaration of conformity, stating that the construction product is in conformity with the provisions of the European technical approval ETA-11/0191 issued on 28 June 2011.

3.2.2 Tasks for the approved bodies

The approved body shall perform the

- initial type-testing of the product,

in accordance with the provisions laid down in the control plan.

The approved body shall retain the essential points of its actions referred to above and state the results obtained and conclusions drawn in written reports.

3.3 CE marking

The CE marking shall be affixed on each packaging of fastening screws. The letters "CE" shall be followed by the identification number of the approved certification body, where relevant, and be accompanied by the following additional information:

- the name and address of the producer (legal entity responsible for the manufacture),
- the last two digits of the year in which the CE marking was affixed,
- the number of the European technical approval,
- the name of the product.

4 Assumptions under which the fitness of the product for the intended use was favourably assessed

4.1 Manufacturing

The fastening screws TDBL-T 8,6 x L and TDBL-T 10,6 x L are manufactured in accordance with the provisions of the European technical approval using the manufacturing process as laid down in the technical documentation.

⁹ The "control plan" is a confidential part of the European technical approval and only handed over to the approved body involved in the procedure of attestation of conformity. See section 3.2.2.

The European technical approval is issued for the product on the basis of agreed data/information, deposited with Deutsches Institut für Bautechnik, which identifies the product that has been assessed and judged. Changes to the product or production process, which could result in this deposited data/information being incorrect, should be notified to Deutsches Institut für Bautechnik before the changes are introduced. Deutsches Institut für Bautechnik will decide whether or not such changes affect the approval and consequently the validity of the CE marking on the basis of the approval and if so whether further assessment or alterations to the approval shall be necessary.

4.2 Design

Fastening screws TDBL-T 8,6 x L and TDBL-T 10,6 x L may completely or partly exposed to external weather or similar conditions up to corrosion category C3 according to EN ISO 12944-2 as long as the influence of sulphur dioxide is avoided.

For the types of connection (a, b, c, d) listed in the Annexes it is not necessary to take into account the effect of constraints due to temperature. For other types of connection it shall be considered for design as long as constraining forces due to temperature do not occur or are not significant (e. g. sufficient flexibility of the structure).

The loading is predominantly static. (Remark: Wind loads are regarded as predominantly static.)

Dimensions, material properties, torque moments $M_{t,norm}$, minimum effective screw-in length l_{ef} and nominal material thicknesses t_N as stated in the ETA or in the Annexes are observed.

The verification concept stated in EN 1990:2002 + A1:2005 + A1:2005/AC:2010 is used for the design of the connections made with the fastening screws. The characteristic values (shear and tension resistance) stated in the Annexes are used for the design of the entire connections.

The following formulas are used to calculate the values of design resistance:

$$N_{Rd} = \frac{N_{Rk}}{\gamma_M}$$

$$V_{Rd} = \frac{V_{Rk}}{\gamma_M}$$

The recommended partial safety factor $\gamma_M = 1.33$ is used in order to determine the corresponding design resistances, provided no values are given in national regulations of the member state in which the fastening screws are used or in the respective National Annex to Eurocode 3.

In case of combined tension and shear forces the linear interaction formula according to EN 1993-1-3:2006 + AC:2009, section 8.3 (8) is taken into account.

$$\frac{N_{Sd}}{N_{Rd}} + \frac{V_{Sd}}{V_{Rd}} \leq 1.0$$

The possibly required reduction of the tension resistance (pull-through resistance) due to the position of the fastener is taken into account:

- in accordance with EN 1993 1 3:2006+ AC:2009, section 8.3 (7) and Fig. 8.2 (component I is made of steel) or EN 1999-1-4:2007 + A1:2011, section 8.1 (6) and Table 8.3 (component I is made of aluminium),
- of 0.7 if the supporting structure is an asymmetric profile (e.g. Z-profile) with $t_{II} < 5$ mm

4.3 Installation

The installation is only carried out according to the manufacturer's instructions. The manufacturer hands over the assembly instructions to the assembler.

It is guaranteed by the execution that no bimetallic corrosion will occur.

For regular shear forces the components I and II are directly connected to each other so that the fastening screws do not get additional bending. The use of compression resistant thermal insulation strips up to a thickness of 3 mm is allowed.

The fastening screws TDBL-T 8,6 x L and TDBL-T 10,6 x L are fixed rectangular to the surface of the components to guarantee a correct load bearing and if necessary rain-proof connection.

The conformity of the installed fastening screws TDBL-T 8,6 x L and TDBL-T 10,6 x L with the provisions of the ETA is attested by the executing company.

5 Indications to the manufacturer

It is in the responsibility of the manufacturer to ensure that the information on the specific conditions according to 1, 2, 4.2 and 4.3 (including Annexes referred to) is given to those who are concerned. This information may be given by reproduction of the respective parts of the European technical approval.

In addition all installation data (predrill diameter, torque moment, application limits) shall be shown clearly on the package and/or on an enclosed instruction sheet, preferably using illustration(s).

Andreas Kummerow
p. p. Head of Department

beglaubigt:
Ulbrich

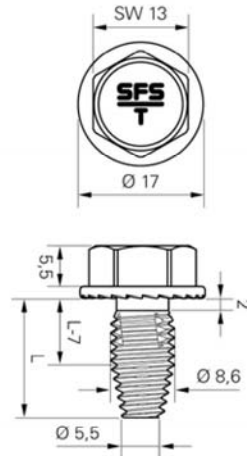

TDBL-T 8,6 x L

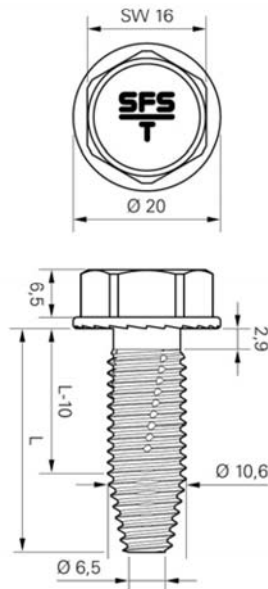

TDBL-T 10,6 x L

Self tapping screw

TDBL-T 8,6 x L and TDBL-T 10,6 x L

Annex 1

to European technical approval

ETA-11/0191

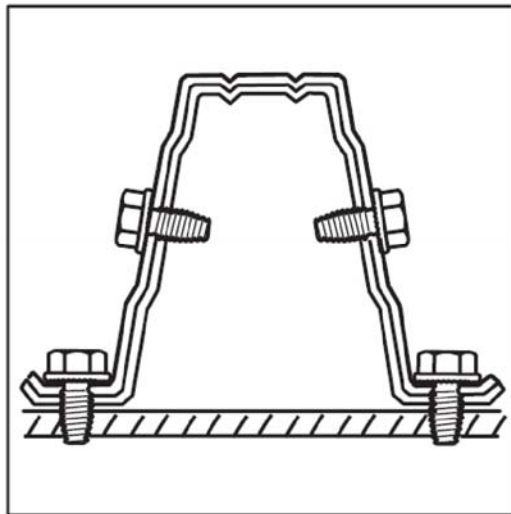
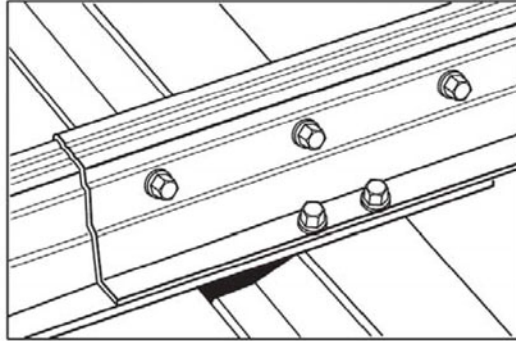

Self tapping screw

TDBL-T 8,6 x L and TDBL-T 10,6 x L
Examples of application

Annex 2

to European technical approval

ETA-11/0191

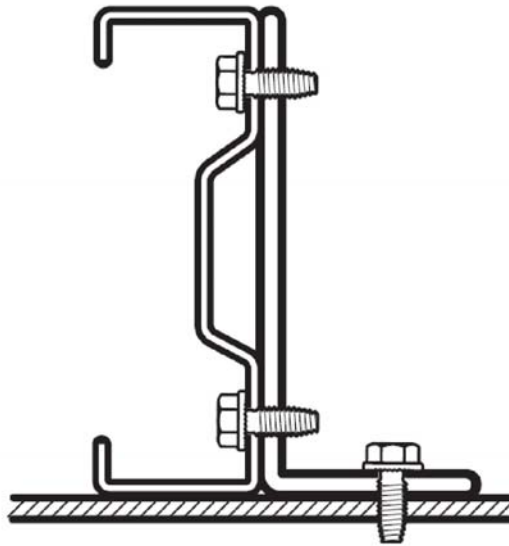

Self tapping screw

TDBL-T 8,6 x L and TDBL-T 10,6 x L
Examples of application

Annex 3

to European technical approval

ETA-11/0191

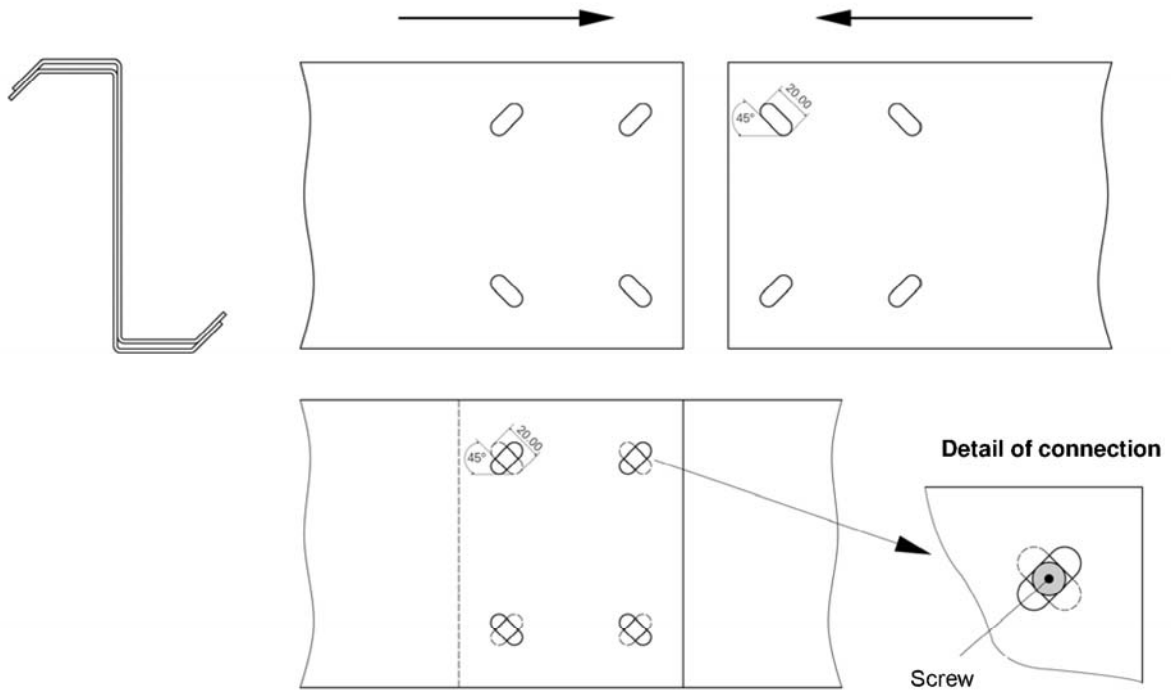

Self tapping screw

TDBL-T 10,6 x L
Examples of application

Annex 4

to European technical approval
ETA-11/0191

Single connection

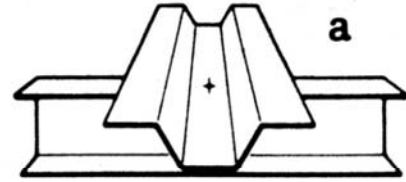

Side lap connection

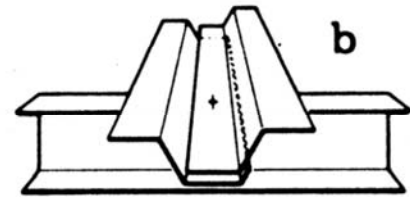

End overlap connection

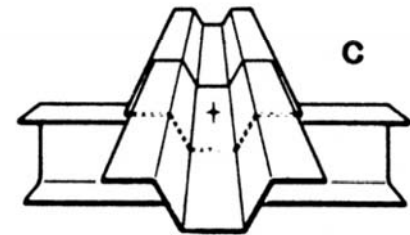

Side lap + end overlap connection

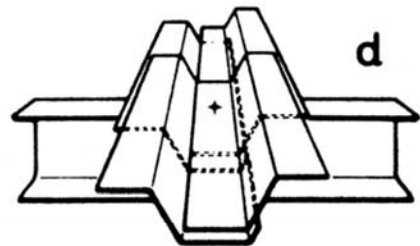

Self tapping screw

TDBL-T 8,6 x L and TDBL-T 10,6 x L
Types of connections with sheeting

Annex 5

to European technical approval

ETA-11/0191

	<p>Materials</p> <p>Fastener: carbon steel quenched, tempered and coated</p> <p>Component I: S235 – EN 10025-1 S280GD or S320GD – EN 10346</p> <p>Component II: S235 – EN 10025-1 S280GD or S320GD – EN 10346</p>
	<p>Predrill diameter d_{pd} see table below</p>
	<p>Timber substructures</p> <p>for timber substructures no performance determined</p>

$t_{N,II} =$	0,88	0,90	1,00	1,25	1,50	2,00	3,00	4,00	6,00	8,00	> 10,00	
$d_{pd} =$	7,5 mm						8,0 mm					
$M_{t, nom} =$	—											
V_{Rk} for $t_{N,I} =$	0,88	2,37	2,40	2,56	2,94	3,33	4,11 ac	4,11 ac	4,11 ac	4,11 ac	4,11 ac	4,11 ac
	0,90	—	2,62	2,62	3,04	3,47	4,31	4,95 ac	4,95 ac	4,95 ac	4,95 ac	4,95 ac
	1,00	—	—	2,84	3,36	3,89	4,93	7,02 ac	7,02 ac	7,02 ac	7,02 ac	7,02 ac
	1,13	—	—	—	3,77	4,32	4,93	7,62	8,73 ac	8,73 ac	8,73 ac	8,73 ac
	1,25	—	—	—	4,14	4,71	5,86	8,14	10,4 ac	10,4 ac	10,4 ac	10,4 ac
	1,50	—	—	—	—	5,52	6,15	8,14	10,4	11,2 ac	11,2 ac	11,2 ac
	1,75	—	—	—	—	—	8,00	8,96	10,4	11,9 ac	12,8 ac	12,8 ac
	2,00	—	—	—	—	—	9,99	10,7	11,5	13,0	14,5 ac	14,5 ac
3,00	—	—	—	—	—	—	14,0	15,5	18,5	21,6	24,6 ac	
4,00	—	—	—	—	—	—	—	—	—	—	—	
N_{Rk} for $t_{N,I} =$	0,88	1,10	1,13	1,29	1,84	2,59	3,11 ac	3,11 ac	3,11 ac	3,11 ac	3,11 ac	3,11 ac
	0,90	—	1,13	1,29	1,84	2,59	3,17	3,17 ac	3,17 ac	3,17 ac	3,17 ac	3,17 ac
	1,00	—	—	1,29	1,84	2,59	3,47	3,47 ac	3,47 ac	3,47 ac	3,47 ac	3,47 ac
	1,13	—	—	—	1,84	2,59	3,88	4,29	4,29 ac	4,29 ac	4,29 ac	4,29 ac
	1,25	—	—	—	1,84	2,59	3,88	5,11	5,11 ac	5,11 ac	5,11 ac	5,11 ac
	1,50	—	—	—	—	2,59	3,88	7,86	9,06	9,06 ac	9,06 ac	9,06 ac
	1,75	—	—	—	—	—	3,88	7,86	10,1	10,1 ac	10,1 ac	10,1 ac
	2,00	—	—	—	—	—	3,88	7,86	11,1	11,1	11,1 ac	11,1 ac
3,00	—	—	—	—	—	—	7,86	11,1	11,1	11,1	11,1 ac	
4,00	—	—	—	—	—	—	—	—	—	—	—	

Self tapping screw	<p>Annex 6</p> <p>to European technical approval</p> <p>ETA-11/0191</p>
TDBL-T 8,6xL	

	<p>Materials</p> <p>Fastener: carbon steel quenched, tempered and coated</p> <p>Component I: S275 or S355 – EN 10025-1 S350GD¹⁾ – EN 10346</p> <p>Component II: S275 or S355 – EN 10025-1 S350GD¹⁾ – EN 10346</p>
	<p>Predrill diameter d_{pd} see table below</p>
	<p>Timber substructures</p> <p>for timber substructures no performance determined</p>

$t_{N,II} =$	0,88	0,90	1,00	1,25	1,50	2,00	3,00	4,00	6,00	8,00	$\geq 10,00$
$d_{pd} =$	7,5 mm						8,0 mm				
$M_{t, nom} =$	—										
$V_{F,k}$ for $t_{N,I} =$	0,88	2,38 — 2,41 —	2,57 — 2,96 —	3,35 — 4,14 ac	4,14 ac	4,14 ac	4,14 ac	4,14 ac	4,14 ac	4,14 ac	4,14 ac
	0,90	— — 2,50 —	2,68 — 3,12 —	3,56 — 4,44 —	4,73 ac	4,73 ac	4,73 ac	4,73 ac	4,73 ac	4,73 ac	4,73 ac
	1,00	— — — —	3,11 — 3,68 —	4,25 — 5,40 —	7,68 ac	7,68 ac	7,68 ac	7,68 ac	7,68 ac	7,68 ac	7,68 ac
	1,13	— — — —	— — 4,17 —	4,73 — 5,85 —	8,08 — 9,19 ac	9,19 ac	9,19 ac	9,19 ac	9,19 ac	9,19 ac	9,19 ac
	1,25	— — — —	— — 4,68 —	5,23 — 6,32 —	8,51 — 10,7 ac	10,7 ac	10,7 ac	10,7 ac	10,7 ac	10,7 ac	10,7 ac
	1,50	— — — —	— — — —	6,14 — 6,87 —	8,51 — 10,7 —	10,7 ac	10,7 ac	12,8 ac	12,8 ac	12,8 ac	12,8 ac
	1,75	— — — —	— — — —	— — — —	8,33 — 9,38 —	10,7 — 10,7 ac	12,8 ac	13,6 ac	13,6 ac	13,6 ac	13,6 ac
	2,00	— — — —	— — — —	— — — —	9,99 — 10,7 —	11,5 — 11,5 —	13,0 ac	14,5 ac	14,5 ac	14,5 ac	14,5 ac
	3,00	— — — —	— — — —	— — — —	— — — —	14,0 — 15,5 —	18,5 — 24,6 ac	24,6 ac	24,6 ac	24,6 ac	24,6 ac
	4,00	— — — —	— — — —	— — — —	— — — —	— — — —	— — — —	— — — —	— — — —	— — — —	— — — —
$N_{E,k}$ for $t_{N,I} =$	0,88	1,11 — 1,16 —	1,42 — 1,88 —	2,66 — 3,12 ac	3,12 ac	3,12 ac	3,12 ac	3,12 ac	3,12 ac	3,12 ac	3,12 ac
	0,90	— — 1,16 —	1,42 — 1,88 —	2,66 — 3,23 —	3,23 ac	3,23 ac	3,23 ac	3,23 ac	3,23 ac	3,23 ac	3,23 ac
	1,00	— — — —	1,42 — 1,88 —	2,66 — 3,80 —	3,80 ac	3,80 ac	3,80 ac	3,80 ac	3,80 ac	3,80 ac	3,80 ac
	1,13	— — — —	— — 1,88 —	2,66 — 4,42 —	4,52 — 4,52 ac	4,52 ac	4,52 ac	4,52 ac	4,52 ac	4,52 ac	4,52 ac
	1,25	— — — —	— — 1,88 —	2,66 — 4,42 —	5,23 — 5,23 ac	5,23 ac	5,23 ac	5,23 ac	5,23 ac	5,23 ac	5,23 ac
	1,50	— — — —	— — — —	2,66 — 4,42 —	8,96 — 9,29 —	9,29 ac	9,29 ac	9,29 ac	9,29 ac	9,29 ac	9,29 ac
	1,75	— — — —	— — — —	— — 4,42 —	8,96 — 10,2 —	10,2 ac	10,2 ac	10,2 ac	10,2 ac	10,2 ac	10,2 ac
	2,00	— — — —	— — — —	— — 4,42 —	8,96 — 11,1 —	11,1 — 11,1 ac	11,1 ac	11,1 ac	11,1 ac	11,1 ac	11,1 ac
	3,00	— — — —	— — — —	— — — —	8,96 — 11,1 —	11,1 — 11,1 —	11,1 — 11,1 —	11,1 — 11,1 —	11,1 — 11,1 —	11,1 — 11,1 —	11,1 — 11,1 —
	4,00	— — — —	— — — —	— — — —	— — — —	— — — —	— — — —	— — — —	— — — —	— — — —	— — — —

¹⁾ including S350GD with increased yield strength, for instance $f_{yk} = 380 \text{ N/mm}^2$

Self tapping screw	<p>Annex 7</p> <p>to European technical approval</p> <p>ETA-11/0191</p>
TDBL-T 8,6xL	

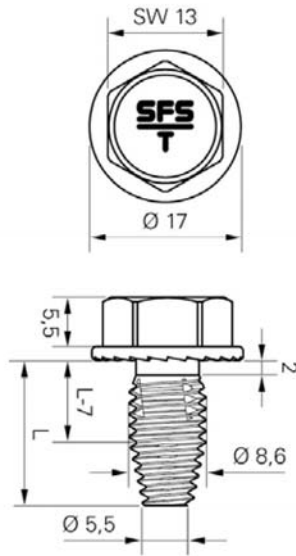

Materials

Fastener: carbon steel
quenched, tempered and coated
Component I: S235, S275 or S355– EN 10025-1
S280GD, S320GD or S350GD¹⁾ – EN 10346
Component II: S235, S275 or S355– EN 10025-1
S280GD, S320GD or S350GD¹⁾ – EN 10346

Predrill diameter d_{pd} see table below

Timber substructures

for timber substructures no performance determined

$t_{N,II} =$	0,88	0,90	1,00	1,25	1,50	2,00	3,00	4,00	$\geq 6,00$	
$d_{pd} =$	7,5 mm						8,0 mm			
$M_{nom} =$	—									
$N_{R,k}$ for $t_{N,II} =$	2 x 0,88	— —	— —	— —	— —	— —	6,90 ac	6,90 ac	6,90 ac	
	2 x 0,90	— —	— —	— —	— —	— —	7,43 ac	7,43 ac	7,43 ac	
	2 x 1,00	— —	— —	— —	— —	— —	10,1 ac	10,1 ac	10,1 ac	
	2 x 1,13	— —	— —	— —	— —	— —	10,1 —	14,5 ac	14,5 ac	
	2 x 1,25	— —	— —	— —	— —	— —	13,9 —	18,9 ac	18,9 ac	
	2 x 1,50	— —	— —	— —	— —	— —	13,9 —	18,9 ac	22,7 ac	
	2 x 1,75	— —	— —	— —	— —	— —	13,9 —	18,9 ac	22,7 ac	
	2 x 2,00	— —	— —	— —	— —	— —	13,9 —	18,9 ac	22,7 ac	
$N_{R,k}$ for $t_{N,I} =$	2 x 0,88	— —	— —	— —	— —	— —	3,11 ac	3,11 ac	3,11 ac	
	2 x 0,90	— —	— —	— —	— —	— —	3,17 ac	3,17 ac	3,17 ac	
	2 x 1,00	— —	— —	— —	— —	— —	3,47 ac	3,47 ac	3,47 ac	
	2 x 1,13	— —	— —	— —	— —	— —	4,29 —	4,29 ac	4,29 ac	
	2 x 1,25	— —	— —	— —	— —	— —	5,11 —	5,11 ac	5,11 ac	
	2 x 1,50	— —	— —	— —	— —	— —	7,86 —	9,06 ac	9,06 ac	
	2 x 1,75	— —	— —	— —	— —	— —	7,86 —	10,1 ac	10,1 ac	
	2 x 2,00	— —	— —	— —	— —	— —	7,86 —	11,1 ac	11,1 ac	

¹⁾ including S350GD with increased yield strength, for instance $f_{yk} = 380 \text{ N/mm}^2$

Self tapping screw

TDBL-T 8,6xL

Annex 8

to European technical approval

ETA-11/0191

Materials

Fastener: carbon steel
quenched, tempered and coated

Component I: S235– EN 10025-1
S280GD or S320GD – EN 10346

Component II: S235– EN 10025-1
S280GD or S320GD – EN 10346

Predrill diameter d_{pd} see table below

Timber substructures
for timber substructures no performance determined

$t_{N,II} =$	0,88	0,90	1,00	1,25	1,50	2,00	3,00	4,00	$\geq 6,00$	
$d_{pd} =$	6,5 mm x 10,0 mm									
$t_{II} =$	7,5 mm						8,0 mm			
$M_{t, norm} =$	—									
$V_{R,k}$ for $t_{N,I} =$	0,88	1,49 ac	1,51 ac	1,62 ac	1,90 ac	2,18 ac	2,73 ac	2,73 ac	2,73 ac	2,73 ac
	0,90	—	1,55 ac	1,64 ac	1,90 ac	2,18 ac	2,73 ac	2,74 ac	2,74 ac	2,74 ac
	1,00	—	—	1,64 ac	1,95 ac	2,30 ac	2,99 ac	4,38 ac	4,38 ac	4,38 ac
	1,13	—	—	—	2,07 ac	2,35 ac	2,91 ac	4,38 ac	4,61 ac	4,61 ac
	1,25	—	—	—	2,25 ac	2,49 ac	2,96 ac	4,38 ac	4,84 ac	4,84 ac
	1,50	—	—	—	—	2,59 ac	3,33 ac	4,38 ac	4,84 ac	5,94 ac
	1,75	—	—	—	—	—	3,33 ac	4,38 ac	4,84 ac	5,94 ac
	2,00	—	—	—	—	—	3,33 ac	4,38 ac	4,84 ac	5,94 ac
$N_{R,k}$ for $t_{N,I} =$	0,88	1,10 ac	1,13 ac	1,29 ac	1,84 ac	2,59 ac	3,43 ac	3,43 ac	3,43 ac	3,43 ac
	0,90	—	1,13 ac	1,29 ac	1,84 ac	2,59 ac	3,45 ac	3,45 ac	3,45 ac	3,45 ac
	1,00	—	—	1,29 ac	1,84 ac	2,59 ac	3,52 ac	3,52 ac	3,52 ac	3,52 ac
	1,13	—	—	—	1,84 ac	2,59 ac	3,88 ac	4,56 ac	4,56 ac	4,56 ac
	1,25	—	—	—	1,84 ac	2,59 ac	3,88 ac	5,60 ac	5,60 ac	5,60 ac
	1,50	—	—	—	—	2,59 ac	3,88 ac	7,63 ac	7,63 ac	7,63 ac
	1,75	—	—	—	—	—	3,88 ac	7,63 ac	7,63 ac	7,63 ac
	2,00	—	—	—	—	—	3,88 ac	7,63 ac	7,63 ac	7,63 ac

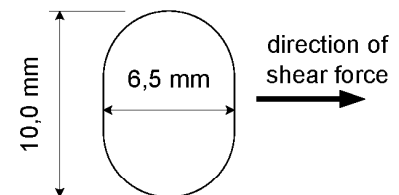

Self tapping screw	Annex 9 to European technical approval ETA-11/0191
TDBL-T 8,6xL	

Materials

Fastener: carbon steel
quenched, tempered and coated

Component I: S275 or S355 – EN 10025-1
S350GD¹⁾ – EN 10346

Component II: S275 or S355 – EN 10025-1
S350GD¹⁾ – EN 10346

Predrill diameter see table below

Timber substructures

for timber substructures no performance determined

$t_{N,II} =$	0,88	0,90	1,00	1,25	1,50	2,00	3,00	4,00	$\geq 6,00$	
$d_{pd} =$ $t_i =$ $t_{ij} =$	6,5 x 10,0 mm									
	7,5 mm						8,0 mm			
$M_{t,nom} =$	—									
$V_{R,k}$ for $t_{N,I} =$	0,88	1,70 ac	1,73 ac	1,85 ac	2,17 ac	2,48 ac	3,11 ac	3,11 ac	3,11 ac	3,11 ac
	0,90	—	1,76 ac	1,89 ac	2,22 ac	2,55 ac	3,20 ac	3,42 ac	3,42 ac	3,42 ac
	1,00	—	—	1,89 ac	2,22 ac	2,61 ac	3,41 ac	4,99 ac	4,99 ac	4,99 ac
	1,13	—	—	—	2,37 ac	2,69 ac	3,41 ac	4,99 ac	5,26 ac	5,26 ac
	1,25	—	—	—	2,59 ac	2,86 ac	3,41 ac	4,99 ac	5,52 ac	5,52 ac
	1,50	—	—	—	—	2,94 ac	3,41 ac	4,99 ac	5,52 ac	6,77 ac
	1,75	—	—	—	—	—	3,41 ac	4,99 ac	5,52 ac	6,77 ac
	2,00	—	—	—	—	—	3,41 ac	4,99 ac	5,52 ac	6,77 ac
$N_{R,k}$ for $t_{N,I} =$	0,88	1,11 ac	1,16 ac	1,42 ac	1,88 ac	2,66 ac	4,00 ac	4,00 ac	4,00 ac	4,00 ac
	0,90	—	1,16 ac	1,42 ac	1,88 ac	2,66 ac	4,02 ac	4,02 ac	4,02 ac	4,02 ac
	1,00	—	—	1,42 ac	1,88 ac	2,66 ac	4,11 ac	4,11 ac	4,11 ac	4,11 ac
	1,13	—	—	—	1,88 ac	2,66 ac	4,42 ac	5,32 ac	5,32 ac	5,32 ac
	1,25	—	—	—	1,88 ac	2,66 ac	4,42 ac	6,53 ac	6,53 ac	6,53 ac
	1,50	—	—	—	—	2,66 ac	4,42 ac	8,90 ac	8,90 ac	8,90 ac
	1,75	—	—	—	—	—	4,42 ac	8,90 ac	8,90 ac	8,90 ac
	2,00	—	—	—	—	—	4,42 ac	8,90 ac	8,90 ac	8,90 ac

¹⁾ including S350GD with increased yield strength, for instance $f_{yk} = 380 \text{ N/mm}^2$

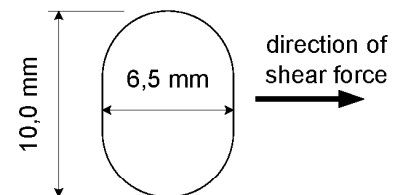

Self tapping screw

TDBL-T 8,6xL

Annex 10

to European technical approval

ETA-11/0191

Materials

Fastener: carbon steel
quenched, tempered and coated

Component I: S235, S275 or S355– EN 10025-1
S280GD, S320GD or S350GD¹⁾ – EN 10346

Component II: S235, S275 or S355– EN 10025-1
S280GD, S320GD or S350GD¹⁾ – EN 10346

Predrill diameter d_{pd} see table below

Timber substructures
for timber substructures no performance determined

$t_{N,II} =$	0,88	0,90	1,00	1,25	1,50	2,00	3,00	4,00	$\geq 6,00$	
d_{pd}	$t_i =$	6,5 mm x 10,0 mm								
	$t_{ij} =$	7,5 mm						8,0 mm		
$M_{n,rem} =$	—									
$V_{F,k}$ for $t_{N,I} =$	2 x 0,88	—	—	—	—	—	—	4,91 ac	4,91 ac	4,91 ac
	2 x 0,90	—	—	—	—	—	—	5,64 ac	5,64 ac	5,64 ac
	2 x 1,00	—	—	—	—	—	—	6,37 ac	6,37 ac	6,37 ac
	2 x 1,13	—	—	—	—	—	—	5,54 ac	7,66 ac	7,66 ac
	2 x 1,25	—	—	—	—	—	—	6,76 ac	8,95 ac	8,95 ac
	2 x 1,50	—	—	—	—	—	—	5,69 ac	7,42 ac	10,9 ac
	2 x 1,75	—	—	—	—	—	—	5,69 ac	7,42 ac	10,9 ac
	2 x 2,00	—	—	—	—	—	—	5,69 ac	7,42 ac	22,7 ac
$N_{F,k}$ for $t_{N,I} =$	2 x 0,88	—	—	—	—	—	—	3,43 ac	3,43 ac	3,43 ac
	2 x 0,90	—	—	—	—	—	—	3,45 ac	3,45 ac	3,45 ac
	2 x 1,00	—	—	—	—	—	—	3,52 ac	3,52 ac	3,52 ac
	2 x 1,13	—	—	—	—	—	—	4,56 ac	4,56 ac	4,56 ac
	2 x 1,25	—	—	—	—	—	—	5,60 ac	5,60 ac	5,60 ac
	2 x 1,50	—	—	—	—	—	—	7,63 ac	7,63 ac	7,63 ac
	2 x 1,75	—	—	—	—	—	—	7,63 ac	7,63 ac	7,63 ac
	2 x \geq 2,00	—	—	—	—	—	—	7,63 ac	7,63 ac	7,63 ac

¹⁾ including S350GD with increased yield strength,
for instance $f_{yk} = 380 \text{ N/mm}^2$

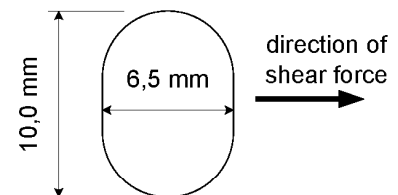

Self tapping screw

TDBL-T 8,6xL

Annex 11

to European technical approval

ETA-11/0191

Materials

Fastener: carbon steel
quenched, tempered and coated

Component I: S235 – EN 10025-1
S280GD or S320GD– EN 10346

Component II: S235 – EN 10025-1
S280GD or S320GD– EN 10346

Predrill diameter d_{pd} see table below

Timber substructures
for timber substructures no performance determined

$t_{N,II} =$	0,88	0,90	1,00	1,25	1,50	2,00	3,00	$\geq 4,00$
$d_{pd} =$	6,5 mm x 10,0 mm							
$M_{t, nom} =$	—							
$V_{R,k}$ for $f_{N,I} =$	0,88	1,49 —	1,49 —	1,49 —	1,49 —	1,49 —	1,49 —	1,49 —
	0,90	— —	1,55 —	1,53 —	1,55 —	1,55 —	1,55 —	1,55 —
	1,00	— —	— —	1,60 —	1,60 —	1,60 —	1,60 —	1,60 —
	1,13	— —	— —	— —	1,93 —	1,93 —	1,93 —	1,93 —
	1,25	— —	— —	— —	2,25 —	2,25 —	2,25 —	2,25 —
	1,50	— —	— —	— —	— —	2,59 —	2,59 —	2,59 —
	1,75	— —	— —	— —	— —	— —	2,59 —	2,59 —
2,00	— —	— —	— —	— —	— —	2,59 —	2,59 —	
$N_{R,k}$ for $f_{N,I} =$	0,88	0,87 —	0,88 —	0,94 —	1,37 —	1,73 —	1,73 —	1,73 —
	0,90	— —	0,88 —	0,94 —	1,37 —	1,73 —	1,73 —	1,73 —
	1,00	— —	— —	0,94 —	1,37 —	1,73 —	1,73 —	1,73 —
	1,13	— —	— —	— —	1,37 —	1,73 —	1,73 —	1,73 —
	1,25	— —	— —	— —	1,37 —	1,73 —	1,73 —	1,73 —
	1,50	— —	— —	— —	— —	1,73 —	1,73 —	1,73 —
	1,75	— —	— —	— —	— —	— —	1,73 —	1,73 —
2,00	— —	— —	— —	— —	— —	1,73 —	1,73 —	

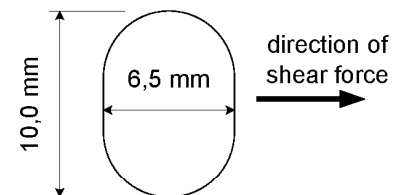

Self tapping screw	Annex 12 to European technical approval ETA-11/0191
TDBL-T 8,6xL	

	<p>Materials</p> <p>Fastener: carbon steel quenched, tempered and coated</p> <p>Component I: S275 or S355 – EN 10025-1 S350GD¹⁾ – EN 10346</p> <p>Component II: S275 or S355 – EN 10025-1 S350GD¹⁾ – EN 10346</p>
	<p>Predrill diameter d_{pd} see table below</p>
	<p>Timber substructures</p> <p>for timber substructures no performance determined</p>

$t_{N,II} =$	0,88	0,90	1,00	1,25	1,50	2,00	3,00	$\geq 4,00$			
$d_{pd} =$	6,5 mm x 10,0 mm										
$M_{t,nom} =$	—										
$V_{R,k}$ for $t_{N,I} =$	0,88	1,70	—	1,70	—	1,70	—	1,70	—	1,70	—
	0,90	—	—	1,69	—	1,76	—	1,76	—	1,76	—
	1,00	—	—	—	—	1,82	—	1,82	—	1,82	—
	1,13	—	—	—	—	2,21	—	2,21	—	2,21	—
	1,25	—	—	—	—	2,59	—	2,59	—	2,59	—
	1,50	—	—	—	—	—	—	2,94	—	2,94	—
	1,75	—	—	—	—	—	—	2,94	—	2,94	—
$N_{R,k}$ for $t_{N,I} =$	0,88	0,99	—	1,00	—	1,07	—	1,56	—	1,97	—
	0,90	—	—	1,00	—	1,07	—	1,56	—	1,97	—
	1,00	—	—	—	—	1,07	—	1,56	—	1,97	—
	1,13	—	—	—	—	—	—	1,56	—	1,97	—
	1,25	—	—	—	—	—	—	1,56	—	1,97	—
	1,50	—	—	—	—	—	—	—	—	1,97	—
	1,75	—	—	—	—	—	—	—	—	1,97	—
2,00	—	—	—	—	—	—	—	—	1,97	—	

¹⁾ including S350GD with increased yield strength, for instance $f_{yk} = 380 \text{ N/mm}^2$

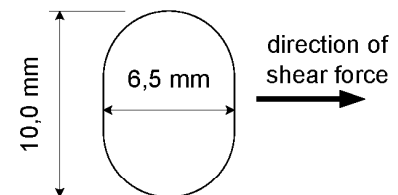

Self tapping screw	<p>Annex 13</p> <p>to European technical approval</p> <p>ETA-11/0191</p>
TDBL-T 8,6xL	

	<p>Materials</p> <p>Fastener: carbon steel quenched, tempered and coated</p> <p>Component I: S235, S275 or S355– EN 10025-1 S280GD, S320GD or S350GD¹⁾ – EN 10346</p> <p>Component II: S235, S275 or S355– EN 10025-1 S280GD, S320GD or S350GD¹⁾ – EN 10346</p>
	<p>Predrill diameter d_{pd} see table below</p>
	<p>Timber substructures</p> <p>for timber substructures no performance determined</p>

$t_{N,II} =$	0,88	0,90	1,00	1,25	1,50	2,00	3,00	$\geq 4,00$		
$d_{pd} =$	6,5 mm x 10,0 mm									
$M_{t,nom} =$	—									
$V_{R,k}$ for $t_{N,I} =$	2 x 0,88	—	—	—	—	—	1,89	—	1,89	—
	2 x 0,90	—	—	—	—	—	1,89	—	1,89	—
	2 x 1,00	—	—	—	—	—	1,89	—	1,89	—
	2 x 1,13	—	—	—	—	—	2,41	—	2,41	—
	2 x 1,25	—	—	—	—	—	2,93	—	2,93	—
	2 x 1,50	—	—	—	—	—	3,08	—	3,08	—
	2 x 1,75	—	—	—	—	—	3,08	—	3,08	—
	2 x 2,00	—	—	—	—	—	3,08	—	3,08	—
$N_{R,k}$ for $t_{N,I} =$	2 x 0,88	—	—	—	—	—	1,73	—	1,73	—
	2 x 0,90	—	—	—	—	—	1,73	—	1,73	—
	2 x 1,00	—	—	—	—	—	1,73	—	1,73	—
	2 x 1,13	—	—	—	—	—	1,73	—	1,73	—
	2 x 1,25	—	—	—	—	—	1,73	—	1,73	—
	2 x 1,50	—	—	—	—	—	1,73	—	1,73	—
	2 x 1,75	—	—	—	—	—	1,73	—	1,73	—
	2 x 2,00	—	—	—	—	—	1,73	—	1,73	—

¹⁾ including S350GD with increased yield strength, for instance $f_{yk} = 380 \text{ N/mm}^2$

Self tapping screw

TDBL-T 8,6xL

Annex 14

to European technical approval

ETA-11/0191

Materials

Fastener: carbon steel
quenched, tempered and coated

Component I: S235 – EN 10025-1
S280GD or S320GD– EN 10346

Component II: S235 – EN 10025-1
S280GD or S320GD– EN 10346

Predrill diameter d_{pd} see table below

Timber substructures
for timber substructures no performance determined

$t_{N,II} =$	1,00	1,25	1,50	2,00	3,00	4,00	5,00	6,00	8,00	$\geq 10,0$	
$d_{pd} =$	9,0 mm					10,0 mm					
$M_{t,nom} =$	—										
$V_{R,k}$ for $t_{N,I} =$	1,00	2,96 —	3,57 —	4,17 —	5,38 —	5,38 ac	5,38 ac	5,38 ac	5,38 ac	5,38 ac	5,38 ac
	1,13	— —	4,13 —	4,72 —	5,90 —	7,08 —	7,08 ac	7,08 ac	7,08 ac	7,08 ac	7,08 ac
	1,25	— —	4,72 —	5,30 —	6,46 —	8,79 —	8,79 ac	8,79 ac	8,79 ac	8,79 ac	8,79 ac
	1,50	— —	— —	6,48 —	7,62 —	9,91 —	12,2 ac	12,2 ac	12,2 ac	12,2 ac	12,2 ac
	1,75	— —	— —	— —	8,63 —	10,3 —	12,2 ac	12,2 ac	13,5 ac	13,5 ac	13,5 ac
	2,00	— —	— —	— —	10,0 —	11,2 —	12,4 —	12,4 —	14,8 ac	14,8 ac	14,8 ac
	3,00	— —	— —	— —	— —	13,8 —	15,6 —	15,6 —	19,2 ac	22,8 ac	22,8 ac
	4,00	— —	— —	— —	— —	— —	21,4 —	21,4 —	21,4 —	22,8 ac	22,8 ac
$N_{R,k}$ for $t_{N,I} =$	1,00	2,22 —	2,39 —	2,55 —	4,02 —	4,29 ac	4,29 ac	4,29 ac	4,29 ac	4,29 ac	4,29 ac
	1,13	— —	2,39 —	2,55 —	4,02 —	5,71 —	5,71 ac	5,71 ac	5,71 ac	5,71 ac	5,71 ac
	1,25	— —	2,39 —	2,55 —	4,02 —	7,13 —	7,13 ac	7,13 ac	7,13 ac	7,13 ac	7,13 ac
	1,50	— —	— —	2,55 —	4,02 —	7,64 —	9,96 ac	9,96 ac	9,96 ac	9,96 ac	9,96 ac
	1,75	— —	— —	— —	4,02 —	7,64 —	11,3 ac	12,2 ac	12,2 ac	12,2 ac	12,2 ac
	2,00	— —	— —	— —	4,02 —	7,64 —	11,3 —	14,4 —	14,4 ac	14,4 ac	14,4 ac
	3,00	— —	— —	— —	— —	7,64 —	11,3 —	14,4 —	14,4 —	14,4 ac	14,4 ac
	4,00	— —	— —	— —	— —	— —	11,3 —	14,4 —	14,4 —	14,4 ac	14,4 ac

Self tapping screw	Annex 15 to European technical approval ETA-11/0191
TDBL-T 10,6xL	

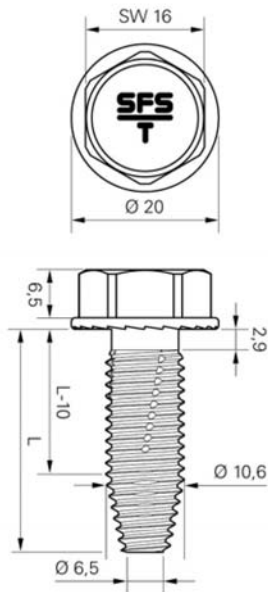

Materials

Fastener: carbon steel
quenched, tempered and coated
Component I: S275 or S355 – EN 10025-1
S350GD¹⁾ – EN 10346
Component II: S275 or S355 – EN 10025-1
S350GD¹⁾ – EN 10346

Predrill diameter d_{pd} see table below

Timber substructures

for timber substructures no performance determined

$t_{N,II} =$	1,00	1,25	1,50	2,00	3,00	4,00	5,00	6,00	8,00	$\geq 10,0$	
$d_{pd} =$	9,0 mm				10,0 mm						
$M_{t,nom} =$	—										
$V_{R,k}$ for $t_{N,I} =$	1,00	3,24 —	3,90 —	4,56 —	5,88 —	5,88 ac	5,88 ac	5,88 ac	5,88 ac	5,88 ac	5,88 ac
	1,13	— —	4,44 —	5,06 —	6,30 —	7,54 —	7,54 ac	7,54 ac	7,54 ac	7,54 ac	7,54 ac
	1,25	— —	5,03 —	5,41 —	7,68 —	9,19 —	9,19 ac	9,19 ac	9,19 ac	9,19 ac	9,19 ac
	1,50	— —	— —	6,81 —	7,95 —	10,2 —	12,5 ac	12,5 ac	12,5 ac	12,5 ac	12,5 ac
	1,75	— —	— —	— —	8,82 —	10,4 —	12,5 ac	12,5 ac	13,7 ac	13,7 ac	13,7 ac
	2,00	— —	— —	— —	10,0 —	11,2 —	12,5 —	12,5 —	14,8 ac	14,8 ac	14,8 ac
	3,00	— —	— —	— —	— —	13,8 —	15,6 —	15,6 —	19,2 —	22,8 ac	22,8 ac
	4,00	— —	— —	— —	— —	— —	25,0 —	25,0 —	25,0 —	25,0 ac	25,0 ac
$N_{R,k}$ for $t_{N,I} =$	1,00	2,43 —	2,53 —	2,62 —	4,58 —	4,69 ac	4,69 ac	4,69 ac	4,69 ac	4,69 ac	4,69 ac
	1,13	— —	2,53 —	2,62 —	4,58 —	6,07 —	6,07 ac	6,07 ac	6,07 ac	6,07 ac	6,07 ac
	1,25	— —	2,53 —	2,62 —	4,58 —	7,45 —	7,45 ac	7,45 ac	7,45 ac	7,45 ac	7,45 ac
	1,50	— —	— —	2,62 —	4,58 —	8,70 —	10,2 ac	10,2 ac	10,2 ac	10,2 ac	10,2 ac
	1,75	— —	— —	— —	4,58 —	8,70 —	12,0 ac	12,3 ac	12,3 ac	12,3 ac	12,3 ac
	2,00	— —	— —	— —	4,58 —	8,70 —	12,0 —	14,4 —	14,4 ac	14,4 ac	14,4 ac
	3,00	— —	— —	— —	— —	8,70 —	12,0 —	14,4 —	14,4 —	14,4 ac	14,4 ac
	4,00	— —	— —	— —	— —	— —	12,0 —	14,4 —	14,4 —	14,4 ac	14,4 ac

¹⁾ including S350GD with increased yield strength, for instance $f_{yk} = 380 \text{ N/mm}^2$

Self tapping screw

TDBL-T 10,6xL

Annex 16

to European technical approval

ETA-11/0191

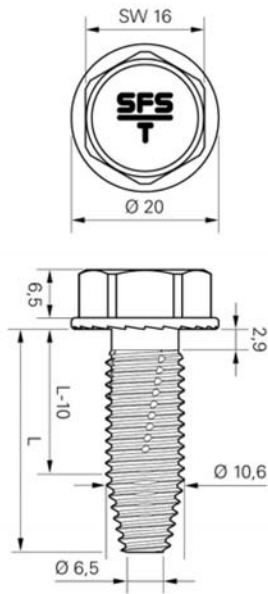

Materials

Fastener: carbon steel
quenched, tempered and coated
Component I: S235 – EN 10025-1
S280GD or S320GD– EN 10346
Component II: S235 – EN 10025-1
S280GD or S320GD– EN 10346

Predrill diameter d_{pd} see table below

Timber substructures

for timber substructures no performance determined

$t_{N,II} =$	1,00	1,50	2,00	3,00	
$d_{pd} =$	8,0 mm x 20,0 mm				
$M_{t,nom} =$	—				
$V_{R,k}$ for $t_{N,I} =$	1,00	1,41 —	1,41 —	1,41 —	1,41 —
	1,50	— —	2,75 —	2,75 —	2,75 —
	2,00	— —	— —	4,01 —	4,01 —
	3,00	— —	— —	— —	10,2 —
$N_{R,k}$ for $t_{N,I} =$	1,00	— —	— —	— —	— —
	1,50	— —	— —	— —	— —
	2,00	— —	— —	— —	— —
	3,00	— —	— —	— —	— —

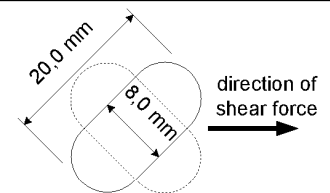

Self tapping screw

TDBL-T 10,6xL

Annex 17

to European technical approval

ETA-11/0191

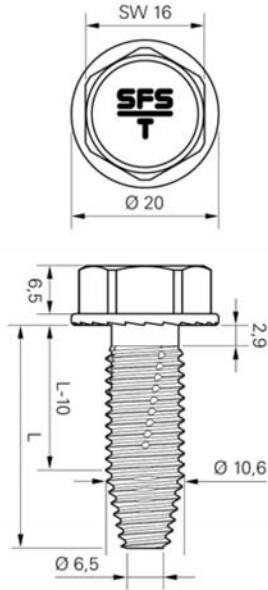

Materials

Fastener: carbon steel
quenched, tempered and coated
Component I: S275 or S355 – EN 10025-1
S350GD¹⁾ – EN 10346
Component II: S275 or S355 – EN 10025-1
S350GD¹⁾ – EN 10346

Predrill diameter d_{pd} see table below

Timber substructures

for timber substructures no performance determined

$t_{N,II} =$	1,00	1,50	2,00	3,00
$d_{pd} =$	8,0 mm x 20,0 mm			
$M_{t,nom} =$	—			
$V_{R,k}$ for $t_{N,I} =$	1,00	1,61 —	1,61 —	1,61 —
	1,50	— —	3,13 —	3,13 —
	2,00	— —	— —	4,57 —
	3,00	— —	— —	11,9 —
$N_{R,k}$ for $t_{N,I} =$	1,00	— —	— —	— —
	1,50	— —	— —	— —
	2,00	— —	— —	— —
	3,00	— —	— —	— —

¹⁾ including S350GD with increased yield strength,
for instance $f_{yk} = 380 \text{ N/mm}^2$

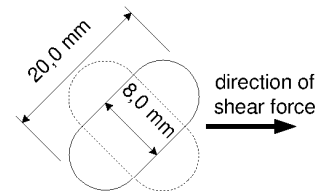

Self tapping screw

TDBL-T 10,6xL

Annex 18

to European technical approval

ETA-11/0191