



European Technical Approval ETA-11/0213

English translation prepared by DIBt - Original version in German language

Handelsbezeichnung
Trade name

BTV Bolzenanker BMC
BTV Anchor bolt BMC

Zulassungsinhaber
Holder of approval

BTV Bautechnik Vertriebs-GmbH
Gartenstraße 43 /1
72764 Reutlingen
DEUTSCHLAND

Zulassungsgegenstand
und Verwendungszweck

*Generic type and use
of construction product*

Kraftkontrolliert spreizender Dübel in den Größen M6, M8, M10, M12,
M16 und M20 zur Verankerung im ungerissenen Beton
*Torque controlled expansion anchor of sizes M6, M8, M10, M12,
M16 and M20 for use in non-cracked concrete*

Geltungsdauer:
Validity:

vom
from

10 June 2011

bis
to

25 September 2012

verlängert
extended

vom
from

26 September 2012

bis
to

26 September 2017

Herstellwerke
Manufacturing plants

BTV Werk 1
BTV manufacturing plant 1

Diese Zulassung umfasst
This Approval contains

15 Seiten einschließlich 8 Anhänge
15 pages including 8 annexes

I LEGAL BASES AND GENERAL CONDITIONS

- 1 This European technical approval is issued by Deutsches Institut für Bautechnik in accordance with:
 - Council Directive 89/106/EEC of 21 December 1988 on the approximation of laws, regulations and administrative provisions of Member States relating to construction products¹, modified by Council Directive 93/68/EEC² and Regulation (EC) N° 1882/2003 of the European Parliament and of the Council³;
 - *Gesetz über das In-Verkehr-Bringen von und den freien Warenverkehr mit Bauprodukten zur Umsetzung der Richtlinie 89/106/EWG des Rates vom 21. Dezember 1988 zur Angleichung der Rechts- und Verwaltungsvorschriften der Mitgliedstaaten über Bauprodukte und anderer Rechtsakte der Europäischen Gemeinschaften (Bauproduktengesetz - BauPG) vom 28. April 1998⁴, as amended by Article 2 of the law of 8 November 2011⁵;*
 - Common Procedural Rules for Requesting, Preparing and the Granting of European technical approvals set out in the Annex to Commission Decision 94/23/EC⁶;
 - Guideline for European technical approval of "Metal anchors for use in concrete - Part 2: Torque controlled expansion anchors ", ETAG 001-02.
- 2 Deutsches Institut für Bautechnik is authorized to check whether the provisions of this European technical approval are met. Checking may take place in the manufacturing plants. Nevertheless, the responsibility for the conformity of the products to the European technical approval and for their fitness for the intended use remains with the holder of the European technical approval.
- 3 This European technical approval is not to be transferred to manufacturers or agents of manufacturers other than those indicated on page 1, or manufacturing plants other than those indicated on page 1 of this European technical approval.
- 4 This European technical approval may be withdrawn by Deutsches Institut für Bautechnik, in particular pursuant to information by the Commission according to Article 5(1) of Council Directive 89/106/EEC.
- 5 Reproduction of this European technical approval including transmission by electronic means shall be in full. However, partial reproduction can be made with the written consent of Deutsches Institut für Bautechnik. In this case partial reproduction has to be designated as such. Texts and drawings of advertising brochures shall not contradict or misuse the European technical approval.
- 6 The European technical approval is issued by the approval body in its official language. This version corresponds fully to the version circulated within EOTA. Translations into other languages have to be designated as such.

¹ Official Journal of the European Communities L 40, 11 February 1989, p. 12
² Official Journal of the European Communities L 220, 30 August 1993, p. 1
³ Official Journal of the European Union L 284, 31 October 2003, p. 25
⁴ *Bundesgesetzblatt Teil I 1998*, p. 812
⁵ *Bundesgesetzblatt Teil I 2011*, p. 2178
⁶ Official Journal of the European Communities L 17, 20 January 1994, p. 34

II SPECIFIC CONDITIONS OF THE EUROPEAN TECHNICAL APPROVAL

1 Definition of the product and intended use

1.1 Definition of the construction product

The BTV Anchor bolt BMC in the range of M6, M8, M10, M12, M16 and M20 is an anchor made of galvanised or stainless steel which is placed into a drilled hole and anchored by torque-controlled expansion.

An illustration of the product and intended use is given in Annex 1.

1.2 Intended use

The anchor is intended to be used for anchorages for which requirements for mechanical resistance and stability and safety in use in the sense of the Essential Requirements 1 and 4 of Council Directive 89/106 EEC shall be fulfilled and failure of anchorages made with these products would cause risk to human life and/or lead to considerable economic consequences. The anchor is to be used only for anchorages subject to static or quasi-static loading in reinforced or unreinforced normal weight concrete of strength classes C20/25 at minimum and C50/60 at most according to EN 206:2000-12.

The anchor may be anchored in non-cracked concrete only.

Anchor made of galvanised steel:

The anchor may only be used in structures subject to dry internal conditions.

Anchor made of stainless steel:

The anchor made of stainless steel A4 may be used in structures subject to dry internal conditions and also in structures subject to external atmospheric exposure (including industrial and marine environment), or exposure in permanently damp internal conditions, if no particular aggressive conditions exist. Such particular aggressive conditions are e.g. permanent, alternating immersion in seawater or the splash zone of seawater, chloride atmosphere of indoor swimming pools or atmosphere with extreme chemical pollution (e.g. in desulphurization plants or road tunnels where de-icing materials are used).

The provisions made in this European technical approval are based on an assumed working life of the anchor of 50 years. The indications given on the working life cannot be interpreted as a guarantee given by the producer, but are to be regarded only as a means for choosing the right products in relation to the expected economically reasonable working life of the works.

2 Characteristics of the product and methods of verification

2.1 Characteristics of the product

The anchor corresponds to the drawings and provisions given in Annexes 2 and 3. The characteristic material values, dimensions and tolerances of the anchor not given in Annexes 2 and 3 shall correspond to the respective values laid down in the technical documentation⁷ of this European technical approval.

The characteristic values for the design of anchorages are given in Annexes 5 to 8.

Each anchor BMC (for standard and reduced anchorage depth $h_{ef,sta}$ und $h_{ef,red}$) is marked with the works symbol, the type of anchor, the thread size, the maximum thickness of fixture for standard anchorage depth and a letter code according to Annex 2.

Each anchor BMC K (for reduced anchorage depth $h_{ef,red}$ only) is marked with the works symbol, the type of anchor, the thread size, the maximum thickness and the letter "K" of fixture for reduced anchorage depth $h_{ef,red}$ and a letter code placed between two hyphens according to Annex 2. Each anchor made of stainless steel A4 is marked with the letter "A4".

The anchor shall only be packaged and supplied as a complete unit.

2.2 Methods of verification

The assessment of fitness of the anchor for the intended use in relation to the requirements for mechanical resistance and stability and safety in use in the sense of the Essential Requirements 1 and 4 has been made in accordance with the "Guideline for European technical approval of Metal Anchors for Use in Concrete", Part 1 "Anchors in general" and Part 2 "Torque-controlled expansion anchors", on the basis of Option 7.

In addition to the specific clauses relating to dangerous substances contained in this European technical approval, there may be other requirements applicable to the products falling within its scope (e.g. transposed European legislation and national laws, regulations and administrative provisions). In order to meet the provisions of the Construction Products Directive, these requirements need also to be complied with, when and where they apply.

3 Evaluation and attestation of conformity and CE marking

3.1 System of attestation of conformity

According to the Decision 96/582/EG of the European Commission⁸ system 2(i) (referred to as system 1) of the attestation of conformity applies.

This system of attestation of conformity is defined as follows:

System 1: Certification of the conformity of the product by an approved certification body on the basis of:

- (a) Tasks for the manufacturer:
 - (1) factory production control;
 - (2) further testing of samples taken at the factory by the manufacturer in accordance with a control plan;

⁷ The technical documentation of this European technical approval is deposited at the Deutsches Institut für Bautechnik and, as far as relevant for the tasks of the approved bodies involved in the attestation of conformity procedure, is handed over to the approved bodies.

⁸ Official Journal of the European Communities L 254 of 08.10.1996

- (b) Tasks for the approved body:
- (3) initial type-testing of the product;
 - (4) initial inspection of factory and of factory production control;
 - (5) continuous surveillance, assessment and approval of factory production control.

Note: Approved bodies are also referred to as "notified bodies".

3.2 Responsibilities

3.2.1 Tasks for the manufacturer

3.2.1.1 Factory production control

The manufacturer shall exercise permanent internal control of production. All the elements, requirements and provisions adopted by the manufacturer shall be documented in a systematic manner in the form of written policies and procedures, including records of results performed. This production control system shall insure that the product is in conformity with this European technical approval.

The manufacturer may only use initial/raw/constituent materials stated in the technical documentation of this European technical approval.

The factory production control shall be in accordance with the control plan which is part of the technical documentation of this European technical approval. The control plan is laid down in the context of the factory production control system operated by the manufacturer and deposited with Deutsches Institut für Bautechnik.⁹

The results of factory production control shall be recorded and evaluated in accordance with the provisions of the control plan.

3.2.1.2 Other tasks for the manufacturer

The manufacturer shall, on the basis of a contract, involve a body which is approved for the tasks referred to in section 3.1 in the field of anchors in order to undertake the actions laid down in section 3.2.2. For this purpose, the control plan referred to in sections 3.2.1.1 and 3.2.2 shall be handed over by the manufacturer to the approved body involved.

The manufacturer shall make a declaration of conformity, stating that the construction product is in conformity with the provisions of this European technical approval.

3.2.2 Tasks for the approved bodies

The approved body shall perform the

- initial type-testing of the product,
- initial inspection of factory and of factory production control,
- continuous surveillance, assessment and approval of factory production control,

in accordance with the provisions laid down in the control plan.

The approved body shall retain the essential points of its actions referred to above and state the results obtained and conclusions drawn in a written report.

The approved certification body involved by the manufacturer shall issue an EC certificate of conformity of the product stating the conformity with the provisions of this European technical approval.

In cases where the provisions of the European technical approval and its control plan are no longer fulfilled the certification body shall withdraw the certificate of conformity and inform Deutsches Institut für Bautechnik without delay.

⁹ The "control plan" is a confidential part of the European technical approval and only handed over to the approved body involved in the procedure of attestation of conformity. See section 3.2.2.

3.3 CE marking

The CE marking shall be affixed on each packaging of the anchor. The letters "CE" shall be followed by the identification number of the approved certification body, where relevant, and be accompanied by the following additional information:

- the name and address of the holder of the approval (legal entity responsible for the manufacture),
- the last two digits of the year in which the CE marking was affixed,
- the number of the EC certificate of conformity for the product,
- the number of the European technical approval,
- the number of the guideline for European technical approval,
- use category (ETAG 001-1 Option 7),
- size.

4 Assumptions under which the fitness of the product for the intended use was favourably assessed

4.1 Manufacturing

The European technical approval is issued for the product on the basis of agreed data/information, deposited with Deutsches Institut für Bautechnik, which identifies the product that has been assessed and judged. Changes to the product or production process, which could result in this deposited data/information being incorrect, should be notified to Deutsches Institut für Bautechnik before the changes are introduced. Deutsches Institut für Bautechnik will decide whether or not such changes affect the approval and consequently the validity of the CE marking on the basis of the approval and if so whether further assessment or alterations to the approval shall be necessary.

4.2 Design of anchorages

The fitness of the anchor for the intended use is given under the following conditions:

The anchorages are designed either in accordance with the

- "Guideline for European technical approval of Metal Anchors for use in concrete", Annex C, method A

or in accordance with the

- CEN/TS 1992-4:2009

under the responsibility of an engineer experienced in anchorages and concrete work.

Verifiable calculation notes and drawings are taking account of the loads to be anchored.

The position of the anchor is indicated on the design drawings (e.g. position of the anchor relative to reinforcement or to supports).

4.3 Installation of anchors

The fitness for use of the anchor can only be assumed if the anchor is installed as follows:

- Anchor installation carried out by appropriately qualified personnel and under the supervision of the person responsible for technical matters of the site,
- Use of the anchor only as supplied by the manufacturer without exchanging the components of an anchor,

- Anchor installation in accordance with the manufacturer's specifications and drawings and using the appropriate tools,
- Checks before placing the anchor to ensure that the strength class of the concrete in which the anchor is to be placed is in the range given and is not lower than that of the concrete to which the characteristic loads apply,
- Check of concrete being well compacted, e.g. without significant voids,
- Edge distances and spacing not less than the specified values without minus tolerances,.
- Positioning of the drill holes without damaging the reinforcement,
- In case of aborted hole: new drilling at a minimum distance away of twice the depth of the aborted hole or smaller distance if the aborted drill hole is filled with high strength mortar and if under shear or oblique tension load it is not in the direction of load application,
- Cleaning of the hole of drilling dust,
- Anchor installation according to manufacturer's instructions given in Annex 8.
- Anchor installation such that the effective anchorage depth is complied with. This compliance is ensured, if the thickness of fixture is not greater than the maximum thickness of fixture marked on the anchor according to Annex 2,
- Application of the torque moment given in Annex 3 using a calibrated torque wrench.

5 Indications to the manufacturer

The manufacturer is responsible to ensure that the information on the specific conditions according to 1 and 2 including Annexes referred to as well as sections 4.2 and 4.3 is given to those who are concerned. This information may be made by reproduction of the respective parts of the European technical approval. In addition all installation data shall be shown clearly on the package and/or on an enclosed instruction sheet, preferably using illustration(s).

The minimum data required are:

- Diameter of drill bit,
- Thread diameter,
- Maximum thickness of the fixture,
- Minimum effective anchorage depth,
- Minimum hole depth,
- Torque moment,
- Information on the installation procedure, including cleaning of the hole, preferably by means of an illustration,
- Reference to any special installation equipment needed,
- Identification of the manufacturing batch.

All data shall be presented in a clear and explicit form.

Uwe Bender
Head of Department

beglaubigt:
Baderschneider

Anchor manufactured by cold - forming:

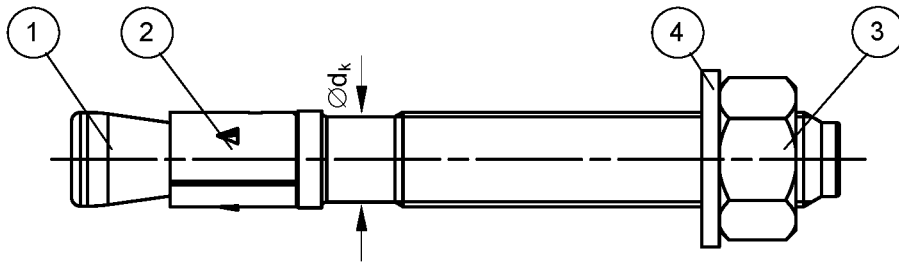

Anchor manufactured by metal - cutting:

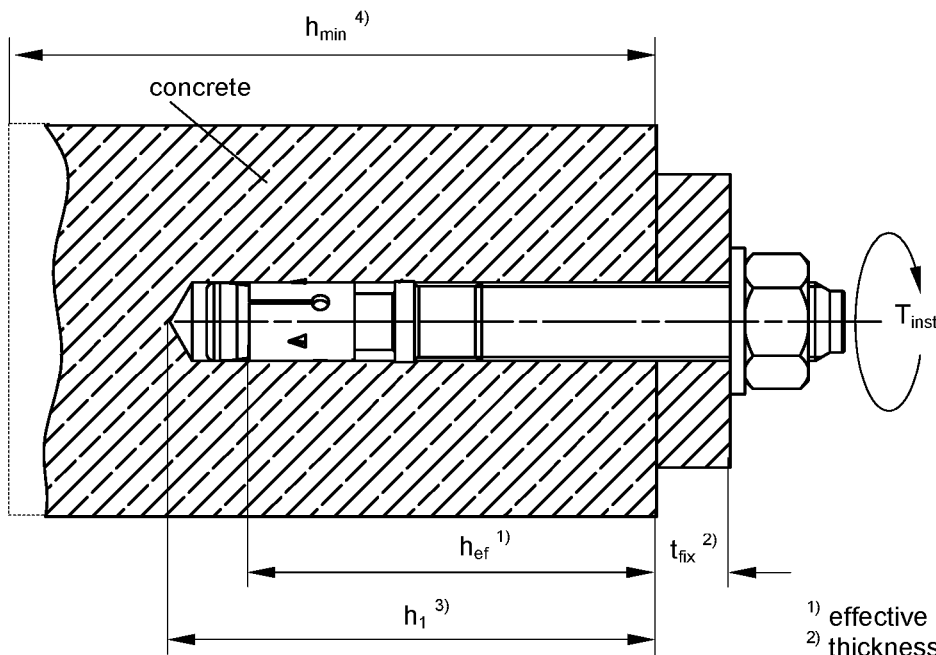
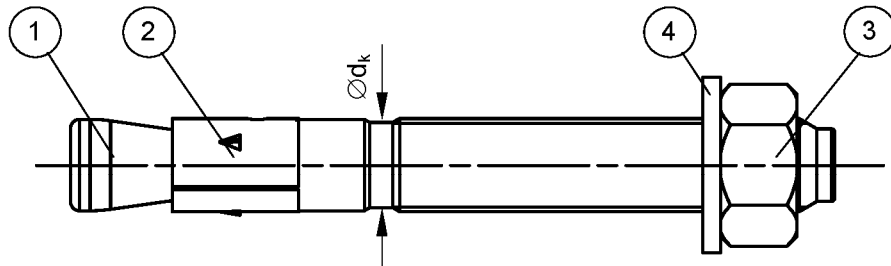

- 1) effective anchorage depth
- 2) thickness of fixture
- 3) drill hole depth
- 4) min. thickness of concrete member

- ① Cone bolt (cold – formed or metal - cut)
- ② Expansion sleeve
- ③ Hexagon nut
- ④ Washer

BTV Anchor bolt BMC

Product and intended use

Annex 1

BMC for use with standard and reduced anchorage depth ($h_{ef, sta}$ and $h_{ef, red}$):

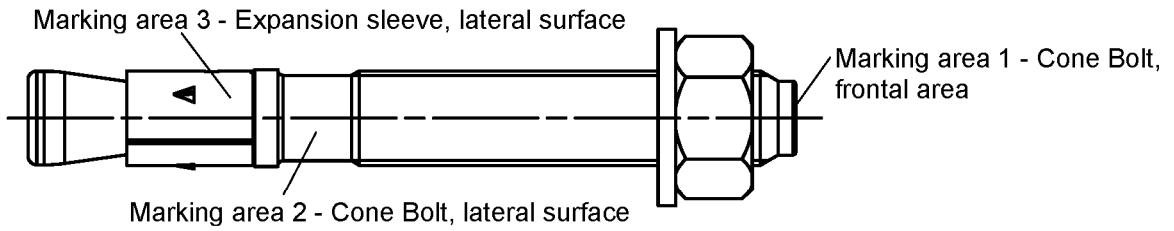

Product marking, example: **BMC** **12/10**
works symbol | type of anchor placed on marking area 2 or marking area 3 thread size / thickness of fixture (t_{fix}) for $h_{ef, sta}$ identification A4 placed on marking area 2

Letter-code on marking area 1 and maximum thickness of fixture t_{fix} :

marking	A	B	C	D	E	F	G	H	I	K	L	M	N	O	P	R	S	T	U	V	W	X	Y	Z	
max. t_{fix} for $h_{ef, sta}$	M6-M20	5	10	15	20	25	30	35	40	45	50	60	70	80	90	100	120	140	160	180	200	250	300	350	400
max. t_{fix} for $h_{ef, red}$	M8, M10	15	20	25	30	35	40	45	50	55	60	70	80	90	100	110	130	150	170	190	210	260	310	360	410
	M12, 16	20	25	30	35	40	45	50	55	60	65	75	85	95	105	115	135	155	175	195	215	265	315	365	415
	M20	30	35	40	45	50	55	60	65	70	75	85	95	105	115	125	145	165	185	205	225	275	325	375	425

BMC K for use with reduced anchorage depth only ($h_{ef, red}$):

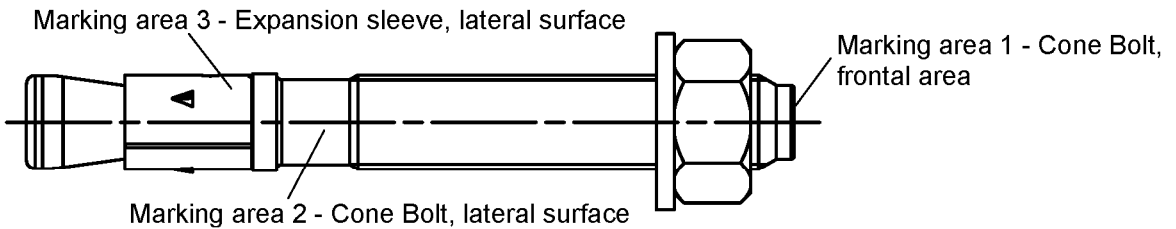

Product marking, example: **BMC** **12/10 K**
works symbol | type of anchor placed on marking area 2 or marking area 3 thread size / thickness of fixture (t_{fix}) identification K for $h_{ef, red}$ | identification A4 placed on marking area 2

Letter-code on marking area 1 and maximum thickness of fixture t_{fix} :

marking	-A-	-B-	-C-	-D-	-E-	-F-	-G-	-H-	-I-	-K-	-L-	-M-	-N-	-O-	-P-	-R-	-S-	-T-	-U-	-V-	-W-	-X-	-Y-	-Z-	
max. t_{fix} for $h_{ef, red}$	M8-M20	5	10	15	20	25	30	35	40	45	50	60	70	80	90	100	120	140	160	180	200	250	300	350	400

Identification for $h_{ef, red}$ is the letter-code between 2 dashes

BTV Anchor bolt BMC

Product marking and identification

Annex 2

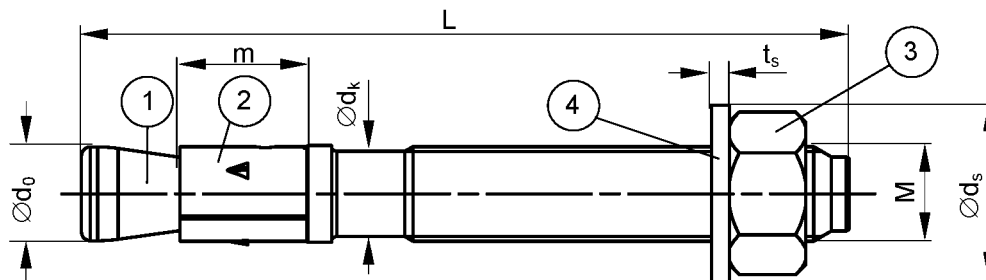

Table 1: Anchor dimensions [mm]

Part	Designation	Deviation	M6	M8	M10	M12	M16	M20
1	Cone bolt	M	M6	M8	M10	M12	M16	M20
		$\varnothing d_0 =$	5,9	7,9	9,9	11,9	15,9	19,6
		$\varnothing d_k =$	5,2	7,1	8,9	10,8	14,5	18,2
2	Expansion sleeve	m =	10	11,5	13,5	16,5	21,5	33,5
3	Hexagon nut	SW	10	13	17	19	24	30
4	Washer	$t_s \geq$	1,0	1,4	1,8	2,3	2,7	2,7
		$\varnothing d_s \geq$	11,5	15	19	23	29	36
	Thickness of fixture t_{fix}	min \geq	0	0	0	0	0	0
		max \leq	200	200	250	300	400	500
	Length of anchor	L_{min}	45	56	71	86	120	139
		L_{max}	245	261	316	396	520	654

Table 2a: Materials BMC

Part	Designation	Material	Treatment
1	Cone bolt	Cold form steel or free cutting steel Nominal steel tensile strength $f_{u,k} \leq 1000 \text{ N/mm}^2$, $A_5 > 8\%$	Zinc plated $\geq 5 \mu\text{m}$ according to EN ISO 4042
2	Expansion sleeve	Cold strip, EN 10139	
3	Hexagon nut	Steel, property class 8, EN ISO 898 - 2	
4	Washer	Cold strip, EN 10139	

Table 2b: Materials BMC A4

Part	Designation	Material	Treatment
1	Cone bolt	stainless steel EN 10 088 Nominal steel tensile strength $f_{u,k} \leq 1000 \text{ N/mm}^2$, $A_5 > 8\%$	coated
2	Expansion sleeve	stainless steel EN 10 088	-
3	Hexagon nut	stainless steel EN 10 088; ISO 3506-2; property class -70	coated on sizes M8-M20
4	Washer	stainless steel EN 10 088	-

BTV Anchor bolt BMC

Anchor dimensions and materials

Annex 3

Table 3: Installation parameters

Type of anchor / size		M6	M8	M10	M12	M16	M20
Nominal drill hole diameter	$d_0 = [\text{mm}]$	6	8	10	12	16	20
Cutting diameter of drill bit	$d_{\text{cut}} \leq [\text{mm}]$	6,45	8,45	10,45	12,5	16,5	20,55
Effective anchorage depth	$h_{\text{ef}} = [\text{mm}]$	30 ²⁾	40 (30 ¹⁾²⁾	50 (40 ¹⁾)	65 (50 ¹⁾)	80 (65 ¹⁾)	105 (80 ¹⁾)
Depth of drill hole in concrete	$h_1 \geq [\text{mm}]$	40	56 (46 ¹⁾²⁾)	68 (58 ¹⁾)	85 (70 ¹⁾)	104 (89 ¹⁾)	135 (110 ¹⁾)
Diameter of clearance hole in the fixture	$d_f \leq [\text{mm}]$	7	9	12	14	18	22
Required torque moment BMC	$T_{\text{inst}} = [\text{Nm}]$	4	15	30	50	100	200
Required torque moment BMC A4	$T_{\text{inst}} = [\text{Nm}]$	4	10	20	35	80	150

¹⁾ Values for application with reduced anchorage depth.

²⁾ Use restricted to anchoring of structural components which are statically indeterminate.

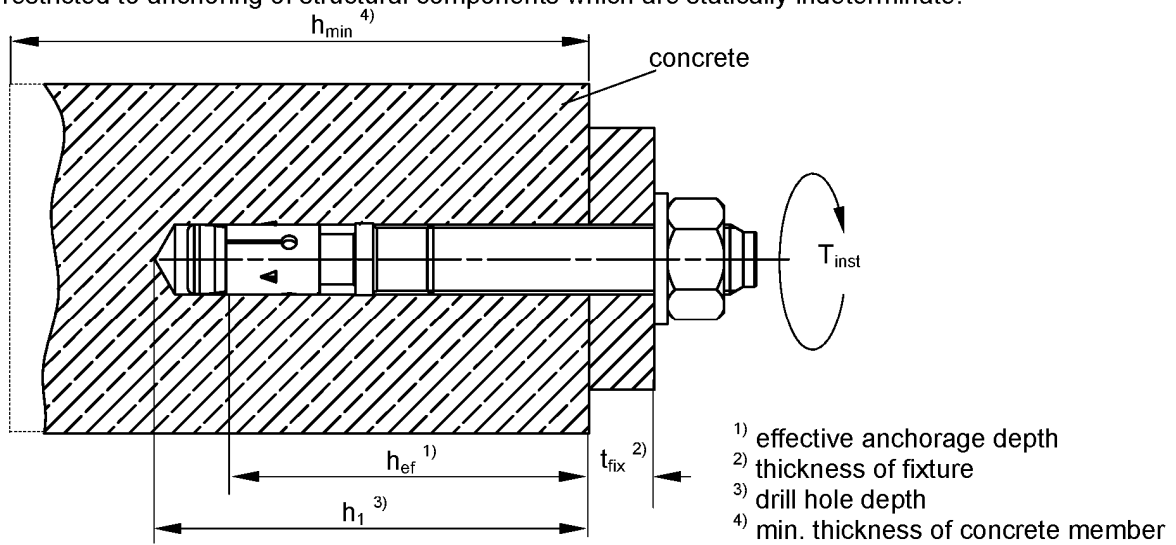

Table 4: Minimum thickness of concrete members, minimum spacing and minimum edge distances of anchors

Type of anchor / size BMC (BMC A4)			M6	M8	M10	M12	M16	M20
Standard embedment depth	Effective anchorage depth	$h_{\text{ef, sta}} [\text{mm}]$	30 ¹⁾	40	50	65	80	105
	Minimum thickness of member	$h_{\text{min}} [\text{mm}]$	100	100	100	120	160	200
	Minimum spacing	$s_{\text{min}} [\text{mm}]$	40	40	50(70 ²⁾)	70	90 (120 ²⁾)	120
	Minimum edge distance	$c_{\text{min}} [\text{mm}]$	40	40(45 ²⁾)	50(55 ²⁾)	70	90(80 ²⁾)	120
Reduced embedment depth	Effective anchorage depth	$h_{\text{ef, red}} [\text{mm}]$	-	30 ¹⁾	40	50	65	80
	Minimum thickness of member	$h_{\text{min}} [\text{mm}]$	-	100	100	100	120	160
	Minimum spacing	$s_{\text{min}} [\text{mm}]$	-	40(50 ²⁾)	50	70	90	120 (140 ²⁾)
	Minimum edge distance	$c_{\text{min}} [\text{mm}]$	-	40(45 ²⁾)	80	100	120	120

¹⁾ Use restricted to anchoring of structural components which are statically indeterminate.

²⁾ Values for BMC A4.

BTV Anchor bolt BMC

Parameters of installation

Annex 4

Table 5: Design method A according to ETAG 001, Annex C
Characteristic values for tension loads

Type of anchor / size			M6 ³⁾	M8	M10	M12	M16	M20
Steel failure for standard and reduced embedment depth BMC								
Characteristic resistance BMC	$N_{Rk,s}$	[kN]	8,3	16,5	27,2	41,6	77,9	107
Partial safety factor	γ_{Ms} ¹⁾	[-]	1,5	1,4	1,4	1,4	1,5	1,5
Steel failure for standard and reduced embedment depth BMC A4								
Characteristic resistance BMC A4	$N_{Rk,s}$	[kN]	10,6	16,5	27,2	41,6	78	111
Partial safety factor	γ_{Ms} ¹⁾	[-]	1,5	1,4	1,4	1,4	1,4	1,5
Pullout for standard embedment depth BMC and BMC A4								
Characteristic resistance	$N_{Rk,p}$	[kN]	6	- ⁴⁾				
Pullout for reduced embedment depth BMC and BMC A4								
Characteristic resistance C20/25	$N_{Rk,p}$	[kN]	-	6 ³⁾	- ⁴⁾			
Increasing factors for $N_{Rk,p}$	ψ_c	C25/30	1,10					
		C30/37	1,22					
		C35/45	1,34					
		C40/50	1,41					
		C45/55	1,48					
		C50/60	1,55					
Partial safety factor	γ_{Mp} ¹⁾	[-]	1,5 ²⁾					
Concrete cone and splitting failure for standard embedment depth BMC and BMC A4								
Effective anchorage depth	$h_{ef,sta}$	[mm]	30	40	50	65	80	105
Spacing	$s_{cr,N}$	[mm]	3 x $h_{ef,sta}$					
Edge distance	$c_{cr,N}$	[mm]	1,5 x $h_{ef,sta}$					
Spacing (splitting failure)	$s_{cr,sp}$	[mm]	130	190	200	290	350	370
Edge distance (splitting failure)	$c_{cr,sp}$	[mm]	65	95	100	145	175	185
Partial safety factor	γ_{Mc} ¹⁾	[-]	1,5 ²⁾					
Concrete cone and splitting failure for reduced embedment depth BMC and BMC A4								
Effective anchorage depth	$h_{ef,red}$	[mm]	-	30 ³⁾	40	50	65	80
Spacing	$s_{cr,N}$	[mm]	3 x $h_{ef,red}$					
Edge distance	$c_{cr,N}$	[mm]	1,5 x $h_{ef,red}$					
Spacing (splitting failure)	$s_{cr,sp}$	[mm]	-	190 ³⁾	200	290	350	370
Edge distance (splitting failure)	$c_{cr,sp}$	[mm]	-	95 ³⁾	100	145	175	185
Partial safety factor	γ_{Mc} ¹⁾	[-]	1,5 ²⁾					

¹⁾ In absence of other national regulations.

²⁾ The partial safety factor $\gamma_2 = 1,0$ is included.

³⁾ Use restricted to anchoring of structural components which are statically indeterminate.

⁴⁾ Pullout failure not relevant.

Table 6: Displacements due to tension loads

Type of anchor / size BMC (BMC A4)			M6	M8	M10	M12	M16	M20
Standard embedment depth	$h_{ef,sta}$	[mm]	30	40	50	65	80	105
Tension load C20/25	N	[kN]	2,8	6,1	8,5	12,6	17,2	25,8
Displacements	δ_{N0}	[mm]	1,9	0,6	0,9	1,5(1,9 ¹⁾)	1,8	1,8(2,0 ¹⁾)
	$\delta_{N\infty}$	[mm]	3,1 (2,7 ¹⁾)					
Reduced embedment depth	$h_{ef,red}$	[mm]	-	30	40	50	65	80
Tension load C20/25	N	[kN]	-	2,8	6,1	8,5	12,6	17,2
Displacements	δ_{N0}	[mm]	-	0,4	0,7	0,7	0,9	1,0
	$\delta_{N\infty}$	[mm]	-	1,6 (1,7 ¹⁾)				

¹⁾ Values for BMC A4

BTV Anchor bolt BMC

Design method A according to ETAG 001, Annex C,
Characteristic values for tension loads,
Displacements

Annex 5

Table 7: Design method A according to ETAG 001, Annex C
Characteristic values for shear loads

Type of anchor / size		M6 ³⁾	M8	M10	M12	M16	M20		
Steel failure without lever arm for standard and reduced embedment depth									
Charact. resistance BMC	$V_{RK,S}$	[kN]	6,0	13,3	21,0	31,3	55,1	67	
Steel failure without lever arm for standard and reduced embedment depth									
Charact. resistance BMC A4	$V_{RK,S}$	[kN]	5,3	12,8	20,3	27,4	51	86	
Steel failure with lever arm for standard embedment depth									
Charact. bending moment BMC	$M^0_{RK,S}$	[Nm]	9,4	26,2	52,3	91,6	232,2	422	
Steel failure with lever arm for standard embedment depth									
Charact. bending moment BMC A4	$M^0_{RK,S}$	[Nm]	8	26	52	85	216	454	
Steel failure with lever arm for reduced embedment depth									
Charact. bending moment BMC	$M^0_{RK,S}$	[Nm]	-	19,9 ³⁾	45,9	90,0	226,9	349	
Steel failure with lever arm for reduced embedment depth									
Charact. bending moment BMC A4	$M^0_{RK,S}$	[Nm]	-	21 ³⁾	47	85	216	353	
Partial safety factor steel failure	γ_{Ms} ¹⁾	[-]	1,25						
Concrete pryout failure for standard embedment depth BMC and BMC A4									
Factor in equation (5.6) of the guideline Annex C, Section 5.2.3.3	k	[-]	1,4	1,8	2,1	2,3	2,3	2,3	
Partial safety factor	γ_{Mc} ¹⁾		1,5 ²⁾						
Concrete pryout failure for reduced embedment depth BMC and BMC A4									
Factor in equation (5.6) of the guideline Annex C, Section 5.2.3.3	k	[-]	-	1,8 ³⁾	2,1	2,3	2,3	2,3	
Partial safety factor	γ_{Mc} ¹⁾	[-]	1,5 ²⁾						
Concrete edge failure for standard embedment depth BMC and BMC A4									
Effective length of anchor	$l_{f,sta}$	[mm]	30	40	50	65	80	105	
Effective external diameter of anchor	d_{nom}	[mm]	6	8	10	12	16	20	
Partial safety factor	γ_{Mc} ¹⁾	[-]	1,5 ²⁾						
Concrete edge failure for reduced embedment depth BMC and BMC A4									
Effective length of anchor	$l_{f,red}$	[mm]	-	30 ³⁾	40	50	65	80	
Effective external diameter of anchor	d_{nom}	[mm]	-	8	10	12	16	20	
Partial safety factor	γ_{Mc} ¹⁾	[-]	1,5 ²⁾						

¹⁾ In absence of other national regulations.

²⁾ The partial safety factor $\gamma_2 = 1,0$ is included.

³⁾ Use restricted to anchoring of structural components which are statically indeterminate.

Table 8: Displacements due to shear loads

Type of anchor / size BMC and BMC A4		M6	M8	M10	M12	M16	M20	
Shear load BMC	V	[kN]	3,4	7,6	12,0	17,9	31,5	38,2
Displacements BMC	δ_{V0}	[mm]	0,7	1,5	1,6	2,0	3,0	2,6
	$\delta_{V\infty}$	[mm]	1,1	2,3	2,4	3,0	4,5	3,9
Shear load BMC A4	V	[kN]	3,0	7,3	11,6	15,7	29,1	49,0
Displacements BMC A4	δ_{V0}	[mm]	1,5	1,4	2,1	2,6	2,7	4,6
	$\delta_{V\infty}$	[mm]	2,3	2,2	3,2	3,9	4,1	7,0

BTV Anchor bolt BMC

Design method A according to ETAG 001, Annex C,
Characteristic values for shear loads,
Displacements

Annex 6

Table 9: Design method A according to CEN/TS 1992-4: 2009
Characteristic values for tension loads

Type of anchor / size			M6 ³⁾	M8	M10	M12	M16	M20
Steel failure for standard and reduced embedment depth BMC								
Characteristic resistance BMC	$N_{Rk,s}$	[kN]	8,3	16,5	27,2	41,6	77,9	107
Partial safety factor	γ_{Ms} ¹⁾	[-]	1,5	1,4	1,4	1,4	1,5	1,5
Steel failure for standard and reduced embedment depth BMC A4								
Characteristic resistance BMC A4	$N_{Rk,s}$	[kN]	10,6	16,5	27,2	41,6	78	111
Partial safety factor	γ_{Ms} ¹⁾	[-]	1,5	1,4	1,4	1,4	1,4	1,5
Pullout								
Pullout for standard embedment depth BMC and BMC A4								
Characteristic resistance	$N_{Rk,p}$	[kN]	6	- ⁴⁾				
Pullout for reduced embedment depth BMC and BMC A4								
Characteristic resistance C20/25	$N_{Rk,p}$	[kN]	-	6 ³⁾	- ⁴⁾			
Increasing factors for $N_{Rk,p}$	ψ_c [-]	C25/30	1,10					
		C30/37	1,22					
		C35/45	1,34					
		C40/50	1,41					
		C45/55	1,48					
		C50/60	1,55					
Partial safety factor	γ_{Mp} ¹⁾	[-]	1,5 ²⁾					
Concrete cone and splitting failure for standard embedment depth BMC and BMC A4								
Effective anchorage depth	$h_{ef,sta}$	[mm]	30	40	50	65	80	105
Factor for uncracked concrete	k_{ucr}	[-]	10,1					
Spacing	$s_{cr,N}$	[mm]	$3 \times h_{ef,sta}$					
Edge distance	$c_{cr,N}$	[mm]	$1,5 \times h_{ef,sta}$					
Spacing (splitting failure)	$s_{cr,sp}$	[mm]	130	190	200	290	350	370
Edge distance (splitting failure)	$c_{cr,sp}$	[mm]	65	95	100	145	175	185
Partial safety factor	$\gamma_{Mc} = \gamma_{Mc}$ ¹⁾	[-]	1,5 ²⁾					
Concrete cone and splitting failure for reduced embedment depth BMC and BMC A4								
Effective anchorage depth	$h_{ef,red}$	[mm]	-	30 ³⁾	40	50	65	80
Factor for uncracked concrete	k_{ucr}	[-]	10,1					
Spacing	$s_{cr,N}$	[mm]	$3 \times h_{ef,red}$					
Edge distance	$c_{cr,N}$	[mm]	$1,5 \times h_{ef,red}$					
Spacing (splitting failure)	$s_{cr,sp}$	[mm]	-	190 ³⁾	200	290	350	370
Edge distance (splitting failure)	$c_{cr,sp}$	[mm]	-	95 ³⁾	100	145	175	185
Partial safety factor	$\gamma_{Mc} = \gamma_{Mc}$ ¹⁾	[-]	1,5 ²⁾					

¹⁾ In absence of other national regulations.

²⁾ The partial safety factor $\gamma_{inst} = 1,0$ is included.

³⁾ Use restricted to anchoring of structural components which are statically indeterminate.

⁴⁾ Pullout failure not relevant.

BTV Anchor bolt BMC

Design method A according to CEN/TS 1992-4:2009,
Characteristic values for tension loads

Annex 7

Table 10: Design method A according to CEN/TS 1992-4: 2009
Characteristic values for shear loads

Type of anchor / size		M6 ³⁾	M8	M10	M12	M16	M20	
Steel failure without lever arm for standard and reduced embedment depth								
Charact. resistance BMC	$V_{Rk,s}$	[kN]	6,07	13,3	21,0	31,3	55,1	67
Steel failure without lever arm for standard and reduced embedment depth								
Charact. resistance BMC A4	$V_{Rk,s}$	[kN]	5,3	12,8	20,3	27,4	51	86
Steel failure with lever arm for standard embedment depth								
Charact. bending moment BMC	$M_{Rk,s}^0$	[Nm]	9,4	26,2	52,3	91,6	232,2	422
Steel failure with lever arm for standard embedment depth								
Charact. bending moment BMC A4	$M_{Rk,s}^0$	[Nm]	8	26	52	85	216	454
Steel failure with lever arm for reduced embedment depth								
Charact. bending moment BMC	$M_{Rk,s}^0$	[Nm]	-	19,9 ³⁾	45,9	90,0	226,9	349
Steel failure with lever arm for reduced embedment depth								
Charact. bending moment BMC A4	$M_{Rk,s}^0$	[Nm]	-	21 ³⁾	47	85	216	353
Ductility factor	k_2		1,0					
Partial safety factor steel failure	$\gamma_{Ms}^{1)}$	[-]	1,25					
Concrete pryout failure for standard embedment depth BMC and BMC A4								
Factor in equation (16) CEN/TS 1992-4-4, Section 6.2.2.3	k_3	[-]	1,4	1,8	2,1	2,3	2,3	2,3
Partial safety factor	$\gamma_{Mc}^{1)}$		1,5 ²⁾					
Concrete pryout failure for reduced embedment depth BMC and BMC A4								
Factor in equation (16) of the CEN/TS 1992-4-4, Section 6.2.2.3	k_3	[-]	-	1,8 ³⁾	2,1	2,3	2,3	2,3
Partial safety factor	$\gamma_{Mc}^{1)}$	[-]	1,5 ²⁾					
Concrete edge failure for standard embedment depth BMC and BMC A4								
Effective length of anchor	$l_{f,sta}$	[mm]	30	40	50	65	80	105
Effective external diameter of anchor	d_{nom}	[mm]	6	8	10	12	16	20
Partial safety factor	$\gamma_{Mc}^{1)}$	[-]	1,5 ²⁾					
Concrete edge failure for reduced embedment depth BMC and BMC A4								
Effective length of anchor	$l_{f,red}$	[mm]	-	30 ³⁾	40	50	65	80
Effective external diameter of anchor	d_{nom}	[mm]	-	8	10	12	16	20
Partial safety factor	$\gamma_{Mc}^{1)}$	[-]	1,5 ²⁾					

¹⁾ In absence of other national regulations.

²⁾ The partial safety factor $\gamma_{inst} = 1,0$ is included.

³⁾ Use restricted to anchoring of structural components which are statically indeterminate.

Installation instruction for the BTV anchor BMC and BMC A4

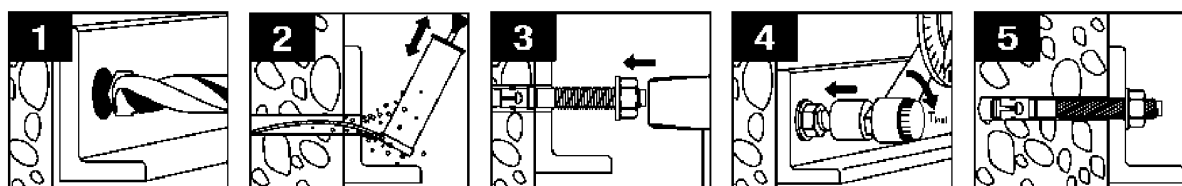

BTV Anchor bolt BMC

Design method A according to CEN/TS 1992-4:2009
Characteristic values for shear loads,
Installation instruction

Annex 8