



## European Technical Approval ETA-12/0418

English translation prepared by DIBt - Original version in German language

Handelsbezeichnung  
*Trade name*

SABA Sealer 35

Zulassungsinhaber  
*Holder of approval*

SABA DINXPERLO BV  
Industriestraat 3  
7091 DC Dinxperlo  
NIEDERLANDE

Zulassungsgegenstand  
und Verwendungszweck

SABA Sealer 35  
als Bestandteil des Fugenabdichtungssystems der SABA Dinxperlo BV  
zur Verwendung in Anlagen zum Lagern, Abfüllen und Umschlagen  
wassergefährdender Stoffe

*Generic type and use  
of construction product*

SABA Sealer 35  
*as a part of the joint sealing system of the SABA Dinxperlo BV used in  
facilities for the storage, filling und handling of substances hazardous to  
water*

Geltungsdauer:  
*Validity:* vom  
*from*  
bis  
*to*

30 April 2013  
26 October 2017

Herstellwerk  
*Manufacturing plant*

SABA Dinxperlo BV,  
Menistraat 7  
NL-7091 ZZ Dinxperlo

Diese Zulassung umfasst  
*This Approval contains*

23 Seiten einschließlich 10 Anhänge  
*23 pages including 10 annexes*

Diese Zulassung ersetzt  
*This Approval replaces*

ETA-12/0418 mit Geltungsdauer vom 26.10.2012 bis 26.10.2017  
*ETA-12/0418 with validity from 26.10.2012 to 26.10.2017*

## I LEGAL BASES AND GENERAL CONDITIONS

- 1 This European technical approval is issued by Deutsches Institut für Bautechnik in accordance with:
  - Council Directive 89/106/EEC of 21 December 1988 on the approximation of laws, regulations and administrative provisions of Member States relating to construction products<sup>1</sup>, modified by Council Directive 93/68/EEC<sup>2</sup> and Regulation (EC) N° 1882/2003 of the European Parliament and of the Council<sup>3</sup>;
  - *Gesetz über das In-Verkehr-Bringen von und den freien Warenverkehr mit Bauprodukten zur Umsetzung der Richtlinie 89/106/EWG des Rates vom 21. Dezember 1988 zur Angleichung der Rechts- und Verwaltungsvorschriften der Mitgliedstaaten über Bauprodukte und anderer Rechtsakte der Europäischen Gemeinschaften (Bauproduktengesetz - BauPG) vom 28. April 1998<sup>4</sup>, as amended by Article 2 of the law of 8 November 2011<sup>5</sup>;*
  - Common Procedural Rules for Requesting, Preparing and the Granting of European technical approvals set out in the Annex to Commission Decision 94/23/EC<sup>6</sup>.
- 2 Deutsches Institut für Bautechnik is authorized to check whether the provisions of this European technical approval are met. Checking may take place in the manufacturing plant. Nevertheless, the responsibility for the conformity of the products to the European technical approval and for their fitness for the intended use remains with the holder of the European technical approval.
- 3 This European technical approval is not to be transferred to manufacturers or agents of manufacturers other than those indicated on page 1, or manufacturing plants other than those indicated on page 1 of this European technical approval.
- 4 This European technical approval may be withdrawn by Deutsches Institut für Bautechnik, in particular pursuant to information by the Commission according to Article 5(1) of Council Directive 89/106/EEC.
- 5 Reproduction of this European technical approval including transmission by electronic means shall be in full. However, partial reproduction can be made with the written consent of Deutsches Institut für Bautechnik. In this case partial reproduction has to be designated as such. Texts and drawings of advertising brochures shall not contradict or misuse the European technical approval.
- 6 The European technical approval is issued by the approval body in its official language. This version corresponds fully to the version circulated within EOTA. Translations into other languages have to be designated as such.

<sup>1</sup> Official Journal of the European Communities L 40, 11 February 1989, p. 12  
<sup>2</sup> Official Journal of the European Communities L 220, 30 August 1993, p. 1  
<sup>3</sup> Official Journal of the European Union L 284, 31 October 2003, p. 25  
<sup>4</sup> *Bundesgesetzblatt Teil I 1998*, p. 812  
<sup>5</sup> *Bundesgesetzblatt Teil I 2011*, p. 2178  
<sup>6</sup> Official Journal of the European Communities L 17, 20 January 1994, p. 34

## II SPECIFIC CONDITIONS OF THE EUROPEAN TECHNICAL APPROVAL

### 1 Definition of product and intended use

#### 1.1 Definition of the construction product

(1) The joint sealing system of the SABA Dinxperlo BV (in the following called "joint sealing system"), is made of:

- Primer,
- self-levelling, joint sealing compound "Saba Sealer 35", (in the following called "joint sealing compound") and
- backfill material.

(2) The following primers are given by the approval holder of the joint sealing system especially for the respective contact material.

(3) A closed-cell backfill material, compatible with the joint sealing compound, is used.

(4) The joint sealing compound is placed in the prepared joint recesses of finished structural elements made from different construction materials (contact material) in a plastic state. There it reacts to form a joint sealing compound with predominantly elastic properties.

(5) The joint sealing compound and the respective primer are matched with the intended contact material. The respective suitable primer is applied to the joint sidewalls before the joint sealing compound is placed.

(6) The joint sealing compound system is applied with a defined ratio of thickness "d" to width "b" (see Annex 1). Evidence of suitability of the respective joint geometry was provided within the scope of the approval tests.

#### 1.2 Intended use

(1) The joint sealing system is intended for use in facilities for the storage, handling and filling of certain substances hazardous to water both inside as well as outside of buildings.

(2) The joint sealing system shall be used for sealing of movement joints, which shall allow unrestrained deformation of structural elements (e.g. shrinkage, temperature-dependent alterations in length or the effects of different ground deformations) and, with regard to their sealing function, shall not be adversely affected.

(3) The joint sealing system may be used under constantly changing mechanical actions due to traffic actions by pneumatic tyres.

(4) The joint sealing system may be installed at normal environmental, structural element and material temperatures (usually within a range of + 5 °C to + 40°C) and used at temperatures between -20°C and + 70°C. The temperature of the water contaminating liquid in contact with the joint sealing system shall not be higher than +30°C.

(5) The joint sealing compound and the respective primer shall be used for the repair of joint sealing compound systems made of the same coloured joint sealing compound of this ETA in existing facilities for the storage, handling and filling of liquid chemicals (substances hazardous to water) (black to black resp. grey to grey).

(6) The intended working life of the joint sealing compound for the intended use in the meaning of the directive 89/106/EEC is 10 years. The indications given on the working life of a product cannot be interpreted as a guarantee given by the producer, but are regarded only as a means for choosing the right products in relation to the expected economically working life of the works.

## 2 Characteristics of the product and methods of verification

### 2.1 General

(1) The joint sealing system shall correspond to the drawings and the details of the annexes of this approval.

(2) The chemical composition or the formula of the joint sealing compound and of the primer shall correspond to the information deposited with Deutsches Institut für Bautechnik.

(3) The characteristics of the material, the dimensions and tolerances which are not declared in this approval shall correspond to the information laid down in the technical documentation<sup>7</sup> of this European technical approval.

### 2.2 Characteristics

(1) The joint sealing system:

- is resistant to the liquids listed in Annex 2 for the stress level S<sub>1</sub>, H<sub>1</sub>, F<sub>1</sub> "low" and/or S<sub>2</sub>, H<sub>2</sub>, F<sub>2</sub> "medium" (definition of stress levels see Annex 10),
- is resistant to hydrolysis in consideration of ISO 868:2003-03 and weather according to EN 14187-8:2003-06,
- is self-levelling,
- is suitable to be attached to certain admissible contact materials (see Annex 5, Table 1) and
- is suitable to be directly applied onto the same coloured joint sealing compound of this approval that has already hardened.

(2) The joint sealing system (see Annex 1 and Annex 3, Table 1 and Figure 1):

- is accessible for pedestrians according to the level of trafficability "t0" and/or passable by vehicles according to the level of trafficability "t1" (see Annex 4, Table 1 in conjunction with Annex 3, Table 1),
- is classified in the class of wear and tear "XM1" (see Annex 4, Table 1),
- is suitable to take up the extension-, compression and shear deformations documented in Annex 7, Table 1 in the area of parallel joint side walls as well as tee and cross intersections without becoming leaky and
- under consideration of the determinations of Annex 3, figure 1 prevents migration of the liquids listed in Annex 2 in the area of the joint.

(3) The joint sealing compound together with the respective primer used between contact materials according to clause 1.1 (2) meets the requirements of the reaction-to-fire class E in accordance with EN 13501-1<sup>8</sup> (see Annex 4, Table 1). The used backfill material has at least to meet the requirements for building products of reaction-to-fire class E in accordance with EN 13501-1<sup>8</sup>.

<sup>7</sup> The technical documentation of this European technical approval is deposited with Deutsches Institut für Bautechnik and shall be made available to the approved bodies, who are involved in the procedure of conformity attestation, for the fulfilment of their tasks.

<sup>8</sup> EN 13501-1: Fire classification of construction products and building elements

## 2.3 Composition

(1) The joint sealing system is made of:

– **joint sealing compound**

"Saba Sealer 35"

consisting of the components A and B, the basis material of which is polysulfide.

– **primer**

"Primer H 17"

consisting of the components A and B, the base material of which is epoxy resin.

"Primer 9911"

consisting of the components A and B, the base material of which is epoxy resin.

The before mentioned primers are useable for special contact materials according Annex 5.

– **Backfill material**

A closed-cell backfill material, compatible with the joint sealing compound, is to be chosen and to be used in accordance with the provisions by the approval holder according to the following criteria:

- A backfill material is to be chosen which prevents the adhesion of the joint sealing compound to the ground of the joint. The backfill material has to be installed sufficiently stable and with the same height "d" (see Annex 1) to observe the dimensions of the joint depth.
- The backfill material shall be installed in such a way that it shows an elliptical cross-section (see Annex 1). It shall be compatible with the joint sealing compound and shall be closed-cell.
- The backfill material shall not inadmissibly impede the change in shape of the joint sealing compound and shall not contain any substances which weaken the adhesion of the joint sealing compound on the joint sidewalls.
- The backfill material may not cause discolorations or bubbles.
- At built-in state the backfill material shall offer sufficient resistance when placing the joint sealing compound.

(2) More information about the individual components of the joint sealing system (mix ratio, airing out, etc.) is given in Annex 4, Table 1.

## 2.4 Emission of dangerous substances

(1) According to the approval holder's declaration the joint sealing system taking account of the EU database<sup>9</sup> does not contain any dangerous substances.

(2) Within the scope of this approval there may be other requirements applicable to dangerous substances resulting from transposed European legislation or applicable national regulations and administrative provisions. These requirements need also to be complied with.

(3) There may be other requirements applicable to the products resulting from other applicable national regulations and administrative provisions. These requirements need also to be complied with.

<sup>9</sup> References in Guidance Paper H: A harmonised approach with regard to the handling of dangerous substances according to the Construction Products Directive, Brussels 18 February 2000

### 3 Evaluation and attestation of conformity and CE marking

#### 3.1 System of attestation of conformity

The European Commission according to its decision on the procedure of attestation of conformity 2003/656/EC of 12 September 2003 (Official Journal of the European Union No L 231 of 17 September 2003) has laid down for joint sealing compounds (EOTA-Nr. 06.05/11) system 2+ for the procedure of attestation of conformity (AoC) (Annex III, clause 2(ii) first possibility of Directive 89/106/EEC) for this type of material.

The AoC System 2+ provides:

- a) Tasks for the approval holder:
  - Initial type-testing of the joint sealing compound and the primer
  - Factory production control including continuous testing of samples taken at the factory
- b) Tasks for the approved bodies:
  - Inspection body: Initial inspection as well as continuous surveillance, assessment and approval of factory production control.
  - Certification body: Granting of a certificate of conformity.

#### 3.2 Responsibilities

##### 3.2.1 Tasks for the approval holder

###### 3.2.1.1 Factory production control

(1) The approval holder shall set up and perform a factory production control. Factory production control means the continuous surveillance of the production to be performed by the respective approval holder, whereby it is ensured that the products manufactured by him correspond to the provisions of the European technical approval.

(2) The approval holder has to perform continuous surveillance of the production process in accordance with the prescribed control plan<sup>10</sup>.

(3) The approval holder may only use initial materials in accordance with the information deposited (according to) in section 2.1(2). He shall inspect or control the initial materials on acceptance according to the prescribed control plan.

(4) The factory production control follows the properties given in the Common Understanding of Assessment Procedure. They are specified in the technical documentation.

(5) The results of the factory production control shall be recorded and evaluated. The records shall include at least the following information:

- description of the product, of the initial materials,
- type of inspection or test,
- date of the manufacture of the product, batch N°, if need be, and date of the inspection or test of the product / the initial materials,
- results of the inspections or tests and, if applicable, comparison with the requirements,
- signature of the person responsible for the factory production control.

(6) The records shall be kept for a minimum of five years. On request they shall be presented to Deutsches Institut für Bautechnik.

<sup>10</sup> The control plan is deposited with Deutsches Institut für Bautechnik and contains the required information on the factory production control and on the initial type-testing. As far as this is relevant to the tasks of the approved body involved in the procedure of attestation of conformity the control plan will be handed over to the approved body.



(7) Details concerning extent, type and frequency of the tests or inspections to be performed within the scope of the factory production control shall correspond to the prescribed control plan<sup>10</sup> which is part of the technical documentation to this ETA.

#### 3.2.1.2 Other tasks for the approval holder

The approval holder shall, on the basis of a contract, involve a body which is approved for the tasks referred to in section 3.1 in the field of joint sealing compounds for the sealing of construction works for the storage, handling and filling of substances hazardous to water in order to undertake the actions laid down in section 3.2.2.

The approval holder shall make a declaration of conformity, stating that the construction product is in conformity with the provisions of this European technical approval

### 3.2.2 Tasks for the approved bodies

#### 3.2.2.1 Inspection body

(1) In each factory where the joint sealing compound is manufactured an initial inspection as well as the factory production control shall be performed by an inspection body.

(2) The inspection body shall continuously control, assess and approve the effectiveness of the factory production control in accordance with the requirements of the control plan<sup>10</sup>. The continuous surveillance shall take place at least twice a year.

(3) On demand the results of the surveillance shall be presented by the inspection body to Deutsches Institut für Bautechnik and, if necessary, to the relevant authority.

(4) The verifications on which the ETA is based were not furnished by samples taken from the current production. Hence initial type-testing shall be performed. The initial type testing involves all tests according control plan with the test liquids for group DF 1a, DF 4 and DF 5a as reference liquids inclusive the reaction to fire of the joint sealing compound with the special contact materials according Annex 5. The results of the initial type-testing shall be presented to Deutsches Institut für Bautechnik.

(5) Observance of the required property values shall be ascertained by the inspection body.

#### 3.2.2.2 Certification body

(1) The certification of the factory production control by a certification body is based on the initial inspection of the manufacturing plant and of the factory production control as well as of the continuous surveillance, assessment and approval of factory production control according to the provisions given in clause 3.2.1.1.

(2) The approved certification body involved by the approval holder shall issue an EC certificate of conformity of the factory production control stating the conformity with the provisions of this European technical approval.

(3) In cases where the provisions of the European technical approval and its control plan are no longer fulfilled the certification body shall withdraw the certificate of conformity and inform Deutsches Institut für Bautechnik without delay.

### 3.3 CE marking

The CE marking<sup>11</sup> (CE marking and identification number of the certification body) shall be affixed on the delivery containers, on the packaging of the components of the joint sealing system, on the delivery note, on signs or labels.

The CE marking shall be accompanied by the following:

- Name or identifying mark of the manufacturing plant
- last two digits of the year in which the CE marking was affixed
- number of the certificate on the factory production control (system 2+)
- name of the product
- number of the ETA

<sup>11</sup> Notes on the CE marking and the declaration of conformity by the approval holder are stated in Guidance Paper D "CE marking under the Construction Products Directive", Brussels, 01 August 2002

- essential properties:
  - reaction-to-fire class,
  - admissible contact material,
  - admissible extension, compression and shear distances in millimetres,
  - admissible levels of road serviceability and
  - resistance to media shall be given with the wording "Resistance to media in accordance with Annex 2 of the ETA".

#### **4 Assumptions under which the fitness of the product for the intended use was favourably assessed**

##### **4.1 Manufacturing**

(1) The manufacture and or the make of the individual components of the joint sealing compound and the primer shall be in accordance with the details deposited with Deutsches Institut für Bautechnik and carried out at the manufacturing plant of the holder of the approval Saba Dinxperlo BV in Industriestraat 3, NL-7091 DC Dinxperlo. Modifications are subject to prior consent by Deutsches Institut für Bautechnik.

(2) The European technical approval is issued for the product on the basis of agreed data/information, deposited with Deutsches Institut für Bautechnik, which identifies the product that has been assessed and judged. Changes to the product or production process, which could result in this deposited data/information being incorrect, should be notified to Deutsches Institut für Bautechnik before the changes are introduced. Deutsches Institut für Bautechnik will decide whether or not such changes affect the approval and consequently the validity of the CE marking on the basis of the approval and if so whether further assessment or alterations to the approval shall be necessary.

##### **4.2 Installation**

###### **4.2.1 Conditions for the installation**

(1) The joint sealing system is planned and designed by expert designers only.

(2) The joints are designed such that they can be controlled during subsequent use.

(3) For the proper installation of the joint sealing system the approval holder draws up installation and handling instructions, which are deposited as part of the technical documentation with Deutsches Institut für Bautechnik.

(4) Joint sealing compounds which are installed in potentially explosive areas do not insulate conductive parts

(5) The additional instructions and technical advice given by the approval holder are paid attention to, e.g. concerning the condition of the joint side walls and adjacent building components or surface sealants.

(6) The serviceability for the respective intended use results from the contact material and the indicated levels and/or performance classes of the categories of use.

(7) Controllable calculations and construction drawings (e.g. joint plans) are made up taking account of the requirements at national level of the respective member states and the stresses and loadings to be expected.

(8) The movable joints are arranged such that the admissible extension, compression and shear distances referred to in Annex 7, Table 1 are complied with.



(9) The following is considered for design and dimensioning:

- Joint sealing compounds are arranged such that they can be used within the scope of the stress level "low" and/or "medium" according to Annex 2 with liquids hazardous to water or that an accumulation of a mixture of dirt and liquids hazardous to water is avoided on the joint sealing compounds. In particular, it is ensured that there is no joint sealing system in the immediate area under filling points.
- The concrete joint side walls shall have enough strength and load-bearing capacity that they are able to accept the occurring stresses acting on them through the joint sealing compound.
- The liquid proof surfaces and/or constructions to be connected shall be designed such that the admissible deformations according to Annex 7, Table 1 (e.g. due to temperature, residual shrinkage or creep) are observed.
- In accordance with the national requirements of the respective member state, the surface sealant (e.g. concrete or asphalt) in which and/or on which the joint sealing system is installed may only show limited penetration depths of liquids. The characteristic penetration depth of the respective liquid in the surface sealant, e.g. made of concrete, shall be smaller than the area of the joint side wall protected by the joint sealing compound "d<sub>H</sub>" (see also Annex 3, figure 1).

#### 4.2.2 Processing

(1) Requirements for the performing company can result from national provisions of the Member States.

(2) Furthermore the installation of joint sealing systems is carried out by companies who (including their specialists) are authorised and trained by the approval holder.

(3) Fitness for use of the installed joint sealing systems can only be assumed, if the processing is performed according to the provisions of this ETA and according to the supplementing installation and processing instructions by the approval holder.

(4) It is to be checked whether the system components of the sealing compound and the primer were not exchanged.

(5) It is to be guaranteed that the maximum admissible joint width according to Annex 3, Table 1 will be warranted observed.

(6) Before the installation of the joint sealing system the suitability of the joints side walls and the building components to be connected is to be ascertained.

- In the case of concrete sealing constructions the concrete of the contact surfaces shall have reached at the time of jointing at least 70 % of the 28-days-strength and be at least 7 days old.
- The joint side walls shall be dry and may not show any impurities.
- Accumulations of precipitation behind joint sealing compounds already installed are to be prevented.
- The surface temperature of the building elements in the area of the joints shall be at least 3 K above thawing temperature during the installation of the joint sealing compound.
- The primer shall be applied evenly on the respective joint side walls. The primer will be applied according to the installation instructions by the approval holder
- The classification of the different primers to the respective contact materials shall be strictly observed (see Annex 5).

(7) When installing the joint sealing system the specifications made by the approval holder or the expert designer (see e.g. the drawing of the joint) shall be observed.

(8) At temperatures of the building component below +5 °C and above +40 °C jointing may not be performed.

(9) The joint sealing compound may not be applied on layers of condensation moisture.

(10) The joint sealing compound and the respective primer shall be mixed according to approval holder's instructions.

(11) The time interval given in Annex 4, Table 1, between applying the primer and installing the joint sealing compound (airing out) may not fall below or be exceeded.

(12) The primer and the joint sealing compound are to be applied evenly and as blister-free as possible.

(13) The release for mechanical and chemical stresses of the sealing construction may only be performed after the period indicated in Annex 4, Table 1 after complete installation of the joint sealing system. For the period of reaction the sealing compound shall be protected from atmospheric exposure in accordance with the definitions by the approval holder.

(14) The attestation of conformity of the installed joint sealing system with the determinations of this ETA and according to the supplementing installation and processing instructions by the approval holder will take place by the installing company according to section 4.2.2 (1) and (2) by means on a report on the production (see Annex 9) based on the controls of the execution in accordance with section 4.2.4.

#### 4.2.3 Correction of defects

(1) Companies according to clause 4.2.2 (1) and (2) are charged with the correction of defects.

(2) The section to be repaired shall be separated from the intact section by conducting a vertical cut.

(3) The defective material shall be removed completely. Unevenness, defects or edges in the area of the joint side walls shall be repaired in accordance with the determinations of section 4.2.1 to 4.2.4. When reprofiling the joint side walls with repair systems the evidence of suitability shall be furnished prior to the use according to the national regulations of the respective Member State.

(4) The determinations of section 4.1 and 4.2 will be complied with.

#### 4.2.4 Control of the execution

(1) Before, during and after the installation of the joint sealing system the following controls are made:

(2) Before the installation:

- For sealing layers made of concrete the strength class of concrete and the water-cement ratio according to EN 206–1 and/or according to the national stipulations of the respective member states (e.g. G: according to the *DAfStb Richtlinie "Betonbau im Umgang mit wassergefährdenden Stoffen (BUmWS)"* ('Concrete construction for handling substances hazardous to water') shall be proven before placing the joint sealing system on site.
- Control of the joint width, the joint distance and the depth of the joint's space according to Annex 1 and/or Annex 3, Table 1 respectively, of the design documents e.g. design of the joint (see section 4.2.1) and/or the processing instructions by the approval holder.
- Control of the condition of the contact areas (bond areas). Dirt accumulations shall be removed thoroughly before the installation.
- Determination of the surface temperature and comparison (3 K above thawing temperature) in accordance with section 4.2.2.

(3) After the installation:

- The installed joint sealing system is examined in full length for flank adhesion. This test can be performed with one of the following methods:
  - Ball stick test
 

In doing this, a stick hemispherical at one end of half a joint width will be impressed approx. 2 mm in the joint.

– Pulley test

By using a circular metal disc of roughly 100 mm in diameter, the thickness of which is half as wide as the joint width and where the circumferential surface is semicircular, the impression test will be carried out continuously. For doing that the disc is provided with an axle and installed in a device which will be sufficiently loaded (impress approx. 2 mm deep). The device prepared like this will be pulled slowly over the joint sealing system.

#### 4.2.5 Repair works in used facilities

(1) The repair works shall be planned and designed by expert designers only based on this ETA, an expertise of the construction level and the repair concept, based on this expertise.

The respective repair works shall be designed in such a way that the interaction between the selected joint sealing systems on the sealing construction will be considered, e.g. penetration behaviour of the liquid and the resulting joint width from it. The determination of the penetration behaviour into the concrete sealing construction shall be performed according to the national regulations of the respective Member State (in G.: TRwS 786, section 9).

(2) The repair of the connected sealing construction (contact material) shall be performed only based on the verification of applicability of the respective sealing construction.

(3) Before the repair works starts make sure, that the detected damages of the sealing construction and there reasons according to the expertise of the construction level are cleared away.

(4) For the repair of the joint sealing system apply the provisions of this ETA and the addition provisions of the approval holder.

(5) With the repair works only firms in accordance with section 4.2.2(1) and (2) shall be assigned.

(6) If there are essential repair works necessary the inspection of the correct state of the facility by an approved expert shall be arranged by the operator of the facility before putting the facility into operation again.

#### 4.3 Responsibilities for the approval holder

It is the approval holder's responsibility to make sure that all those who use his joint sealing system will be appropriately informed about the specific conditions according to sections 1, 2, 4, and 5 including the annex to this ETA, the installation and processing instructions by the approval holder and the not confidential part of the technical documentation to this ETA.

This information can be given by reproduction of the corresponding parts of the European technical approval.

### 5 Indications to the approval holder

#### 5.1 Packaging, transport and storage

(1) Packaging, transport and storage of the single components of the joint sealing system shall be such that the fitness for the intended use will not be affected. All components of the joint sealing system and the respective primer shall in particular be stored in closed original containers/packs protected against moisture preferably at room temperatures. The maximum storage time indicated on the containers/packs shall be observed.

(2) The components of the joint sealing system shall not be exposed to direct solar radiation. They are to be stored such that the temperature of the material at the time of processing is higher than +10 °C and lower than +40 °C.

(3) The information on requirements from other fields of the law (e.g. law relating to hazardous substances and/or law relating to transport) given on the containers/packs shall be observed.

## 5.2 Use, maintenance and repair

(1) In order to ensure the fitness for use of the joint sealing system after their installation in the construction works, the measures given in clauses (2) to (6) are recommended. It is the task of the approval holder to make sure that all parties involved are adequately informed.

(2) The operator of the respective facility establishes operating instructions including, among others, the description of the necessary measures

- for the control of the proper condition
- for ensuring proper operation
- for maintenance and repair

of the joints as well as the description of measures to be taken in case of damage. The inspection intervals are specified according to the stress levels given in Annex 2 in conjunction with Annex 10 of this ETA. The inspection results are documented.

(3) Major dripping losses and/or accumulations of already minor liquid quantities are directly removed.

(4) Leaked out substances hazardous to water will immediately be bound with suitable means. The polluted bonding agent is taken up and recycled duly and without loss or is disposed of. Appropriate materials and/or employment devices are specified in the operating instructions and are constantly ready in sufficient quantity. For the disposal and treatment, respectively, of the materials resulting in waste reference is made to the applicable regulations of the respective Member State (e.g. in G: Kreislaufwirtschafts- und Abfallgesetz ('Act for Promoting Closed Substance Cycle Waste Management and Ensuring Environmentally Compatible Waste Disposal')).

(5) Before the operation of a facility and after repair measures of larger extent start-up inspections are carried out as follows:

- The start-up inspection is carried out by expert personnel only. Further requirements for the individuals can result from national regulations of the Member States.
- The person put in charge of the inspection will constantly be kept informed on the process of the work. The person is given the possibility to participate in the controls of the joint sealing system before and after the installation according to section 4.2.3.4 and to evaluate the results of the controls.
- Checking the condition of the installed joint sealing systems is done via visual inspection of the surface of all joints of the respective sealing construction.
- The person put in charge of the inspection examines the intended control intervals (according to section 5.2 (2)) of the operating instructions by the operator of the respective facility.

(6) One year after every start-up inspection, then after four years and then every fifth year recurring inspections shall be performed as follows:

- The recurring inspections are carried out by expert individuals. Further requirements for the individuals can result from national regulations of the Member States.
- The investigation of the condition of the joint sealing system is done via visual check of the joint sealing in all areas of the respective sealing construction. Particular attention shall be paid to possible edge spalling in the chamfer area.
- In addition the examination for tightness shall be carried out by audit-testing of the joint sealing system for side wall bonding following section 4.2.4(3) (ball stick or pulley test).
- On the basis of the documentation in accordance with section 5.2 (2) it is checked whether
  - the check intervals were kept,
  - the specifications of the operating instructions are observed and
  - no longer contact has occurred between the joint sealing compound and the liquids hazardous to water in the course of use.

- If doubts arise about the tightness of the joint sealing system (e.g. due to softening of the surface of the joint sealing compound) further examinations become necessary. For that purpose samples (drilling core) will be taken from the section concerned, if need be. It can be done without the taking of samples from the soil underneath the joint sealing systems, if demonstrably no complete penetration of the joint sealing system occurred by liquids hazardous to water.
- (7) Further national regulations of the Member States shall remain unaffected.

## **6 Recommendations for the operator of a facility for storage, filling and handling of substances hazardous to water**

(1) Reference is made to the necessity of a permanent surveillance by the operator of the facility for tightness and operability of the joint sealing system in accordance with the requirements of the national regulations of the respective Member States.

(2) An operating instruction shall be prepared by the operator of the respective facility which takes the following points into account:

- The contents of the regulations to be applied by the employee working in these fields will be presented in the operating instructions in a comprehensible and clear way and be laid out or put up at a suitable place of the facility. The operating instruction can be part of operating instructions in accordance with other fields of law of the respective Member States.
- The employees working in these fields will be instructed in the possible threats to water when storing, filling and handling substances hazardous to water as well as in the measures of hazard control. Before working in this field, they will be instructed before working with these substances and afterwards at least once per year.
- All essential measures of control by the operator, the maintenance and the repair will be specified in the operating instructions. The realization of the measures will be noted in each case in the company journal.
- In this operating instruction the operator lays down his inspection intervals with regard to the stress level specified in this ETA in accordance with Annex 2 in conjunction with Annex 10. These records are ready and will be presented to the person responsible according to the national regulations in force of the respective Member States.

(3) The operator of a facility for the storage, filling and handling of substances hazardous to water commissions companies with maintenance, repair and cleaning of the joint sealing systems according to section 4.2.2 (1) and (2).

(4) After each repair work and/or touch up of a larger extent a start-up check will be carried out and the recurring test shall be repeated by the person charged with the test, respectively, in accordance with the effective national regulations of the respective Member States.

(5) The joint sealing system is driven on only with vehicles supplied with pneumatic tyres.

Uwe Bender  
Head of Department

*beglaubigt:*  
Dr.-Ing. Westphal-Kay

## Joint sealing system, pouring-grade, by Saba Dinxperlo BV used in facilities made of special contact materials

**trafficable joint construction**

**not trafficable joint construction**

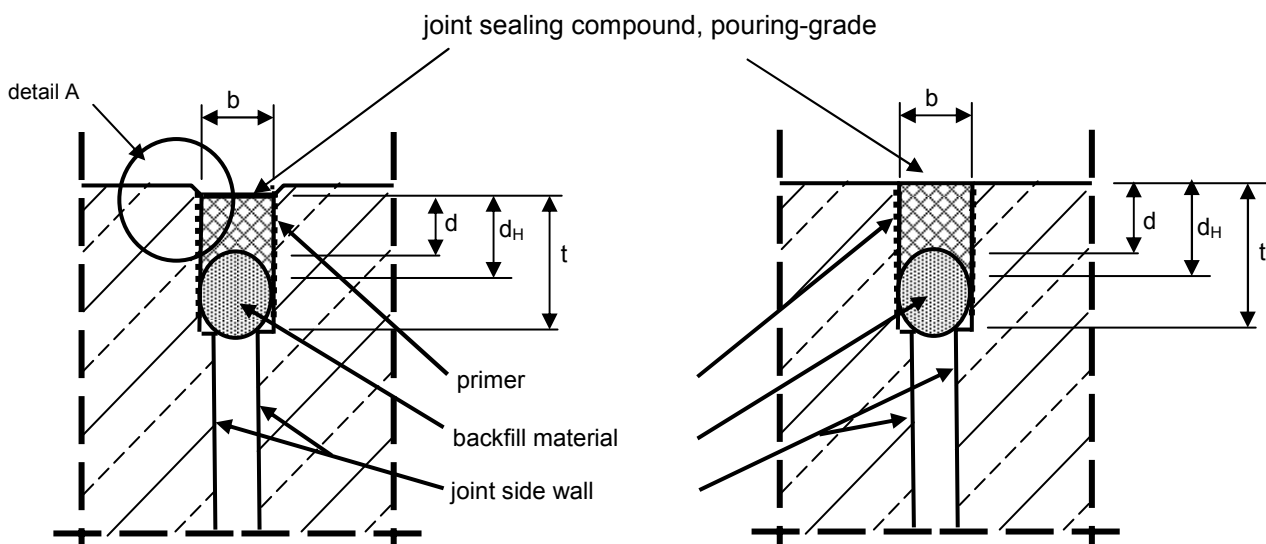

**detail A:**

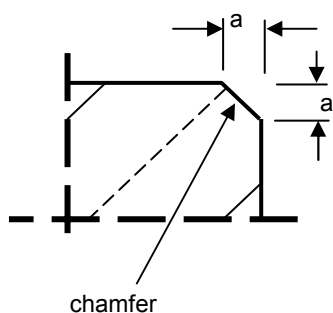

- a** = Chamfer edge (3 to 5) mm
- b** = Joint width (10 to 20) mm (trafficable)
- d** = Thickness of the joint sealing compound
- d<sub>H</sub>** = Joint sealing compound bonding or contact surface on the joint side wall ( $d_H = d + 0.5 b$ ),
- t** = Depth of the joint chamber

SABA Sealer 35 as a component of the joint sealing system of the SABA Dinxperlo BV used in facilities for storage, handling and filling of substances hazardous to water

Product and build-in state

Annex 1



The joint sealing system used in facilities for storage, handling and filling of substances hazardous to water is impermeable and chemically resistant to the following liquids (stress level: S<sub>1</sub>, H<sub>1</sub>, F<sub>1</sub> "low" and S<sub>2</sub>, H<sub>2</sub>, F<sub>2</sub> "medium", see Annex 10).

**Table 1:** List of liquids for stress level S<sub>1</sub>, H<sub>1</sub> and F<sub>1</sub> "low" and use according to level of trafficability "t<sub>0</sub>" (see Annex 4, Table 1) – **trafficable with pedestrians** –

Group No.	liquids
DF 4	All hydrocarbons as well as mixtures containing benzene with max. 5 percentage by volume benzene
DF 4b	Crude oils
DF 4c	Used internal combustion engine oils and used vehicle gear oils with a point of ignition of > 55 °C

**Table 2:** List of liquids for stress level S<sub>2</sub>, H<sub>2</sub> and F<sub>2</sub> "medium" and use according to level of trafficability "t<sub>1</sub>" (see Annex 4, Table 1)– trafficable with pneumatic tyres -

Group No.	liquids
DF 1	Gasoline for spark ignition engines, super and normal according to EN 228 with a maximum 5 percentage by volume of bio-alcohol
DF 1a	Gasoline for spark ignition engines, super and normal according to EN 228 with a maximum 20 percentage by volume of bio-alcohol
DF 2	Aviation gasoline
DF 3	Fuel EL Unused combustion engine oil Unused motor vehicle gear oil Mixture of saturated and aromatic hydrocarbons with an aromatic content ≤ 20 wt.-% and a flash point > 55 °C
DF 3a	Diesel fuel according to EN 590 with a maximum of 5 volume percent of bio-diesel fuel
DF 3b	Diesel fuel according to EN 590 with a maximum of 20 volume percent of bio-diesel fuel
DF 5	Monovalent and polyvalent alcohol (up to a maximum of 48 volume percent of methanol), glycols and polyglycols as well as their monoethers
DF 5a	alcohol and glycol ethers
DF 5b	Monovalent and polyvalent alcohol ≥ C <sub>2</sub> (up to a maximum of 48 volume percent of ethanol)
DF 12	Aqueous solutions of inorganic non-oxidizing salts with a pH value between 6 und 8
-	single liquid: Skydrol 500B-4 (Solutia Europe S.A./N.V.)
-	single liquid: urea with max. 35% in aqueous solution (Adblue acc. ISO 22214 / DIN 70070)
-	single liquid: Ethanol fuel "E85" acc. DIN 51625

SABA Sealer 35 as a component of the joint sealing system of the SABA Dinxperlo BV used in facilities for storage, handling and filling of substances hazardous to water

Lists of liquids

Annex 2



**Table 1:** Dimensions of the joint construction<sup>1)</sup>

Level of trafficability "t1" <sup>2) 3)</sup> – trafficable with pneumatic tyres–		
b	d	d <sub>H</sub>
mm		
10	10	15
Intermediate values can be interpolated		
20	20	30

Level of trafficability "t0" <sup>4)</sup> –trafficable with pedestrians–		
b	d	d <sub>H</sub>
mm		
10	10	15
Intermediate values can be interpolated		
20	20	30

- 1) compare with Annex 1
- 2) For the use with contact materials acc. Annex 5, table 1, No. 2, 3 and 4
- 3) The joint sealing system in sealing constructions made of mastic asphalt is not trafficable with vehicles.
- 4) For the use with all contact materials acc. Annex 5.

**Figure 1:** Migration behaviour in the area of the embedded joint sealing system<sup>1)</sup> in sealing construction made of liquid-tight concrete

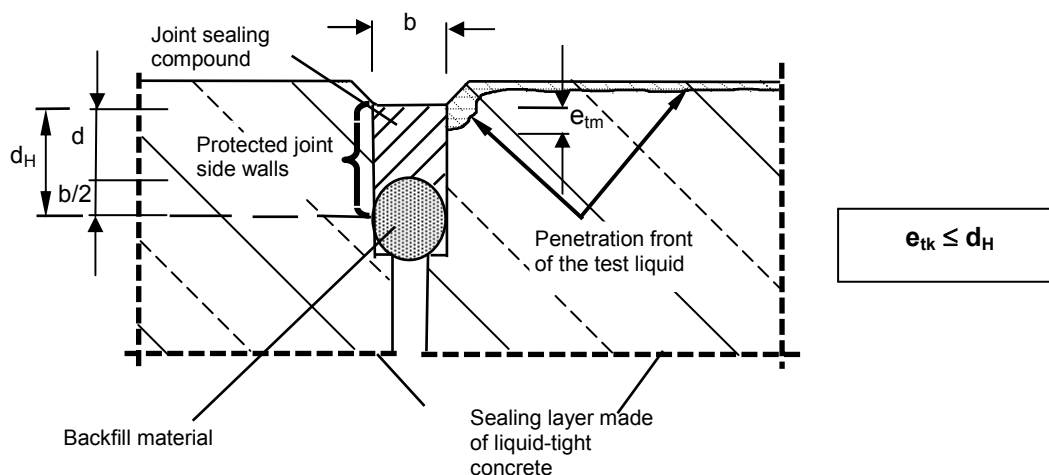

- $d_H$  = bond area and/or contact surface of the joint sealing compound at the joint side wall;  $d_H = d + b/2$
- $b$  = width of the joint sealing compound
- $d$  = thickness of the joint sealing compound;  $d = (0.8 \text{ to } 1.0) \times b$
- $e_{tm}$  = average penetration depth of the water-endangering liquid
- $e_{tk}$  = characteristic penetration depth of the water-endangering liquid;  $e_{tk} = e_{t,m} \times 1.35$

<sup>1)</sup> see also Annex 6, Table 1

SABA Sealer 35 as a component of the joint sealing system of the SABA Dinxperlo BV used in facilities for storage, handling and filling of substances hazardous to water

Dimension of the joint construction and migration behaviour

Annex 3

**Table 1:** Characteristics, levels, classes and characteristic values

No.	Characteristics / level / classes	unit	characteristic values for the joint sealing system facing	
			contact materials according to Annex 5 and 6: - concrete, - fibre concrete - certain concrete repair mortar - mastic asphalt <sup>1)</sup>	
1	<b>Primer</b>	-	Primer H 17	Primer 9911
2	<b>Airing out</b> (at 23°C) of the primer <sup>2)</sup> minimum:	minutes	60	30
3	<b>max. storage time</b> <sup>2)</sup> (at 0 - 40°C) sealing compound:	months	18 (combi-pack)	18 (combi-pack)
	Primer:		18 18	12 12
4	<b>Mixing ratio</b> sealing compound: (comp. A : comp. B)	parts by weight	10 : 6	10 : 6
	primer: (comp. A : comp. B)		10 : 3	100 : 16
5	Working life (Pot-life)	minutes	min. 120 (depending on weather)	
6	<b>Minimum cure time</b> until the complete chemical and mechanical design resistance	hours	16 to 24 (depending on weather)	
7	<b>waiting time</b> until trafficability	hours	16 to 24 (depending on weather)	
8	<b>shade</b> sealing compound: primer:	-	black or grey	
			light yellow	light yellow
9	<b>Backfill material</b>	-	according to ETA and to the additional provisions by the manufacturer	
	reaction to fire class according to EN 13501-1		at least class E	
10	surface temperature of the pavement sealing system in areas of joints during installation	°C K	≥ 5 and ≤ 40, ≥ 3 above temperature of dew point	
11	reaction-to-fire class of the joint sealing compound together with the respective primer Primer H 17 and Primer 9911: class E in accordance with EN 13501-1			
12	Class of wear and tear "XM1": permissible stress by vehicles with pneumatic tyres			
13	Level of trafficability	"t0": suited for traffic with pedestrians only and "t1": suited for traffic with pneumatic tyres only (The joint sealing system installed in sealing constructions made of mastic asphalt is not suited for traffic with vehicles.)		
	Level of trafficability:	concrete	certain concrete repair mortar	mastic asphalt
	- "t0": suited for traffic with pedestrians only	X	X	X
	- "t1": suited for traffic with pneumatic tires only	X	X	----

<sup>1)</sup> > 90 percent by weight mineral components

SABA Sealer 35

Characteristic values for the materials

Annex 4

Table 1: Admissible contact materials		
No	contact materials	comments
1	Sealing layers made of mastic asphalt <sup>1)</sup> (for pedestrians only)	<ul style="list-style-type: none"> <li>- according to the statutory provisions implementing Directives of the European Community, which include the specific requirements of the building authority as well as the law relating to water and which bear the marking of the European Community (CE marking) and/or</li> <li>- according to national provisions of the respective countries, which also include the specific requirements of the building authority as well as the law relating to water and are marked with the intended conformity marking in accordance with the national provisions of the respective countries.</li> </ul>
2	sealing constructions made of concrete <sup>2)</sup> : pre-fabricated elements with and without fibres <sup>3)</sup>	
3	<p>polymer-bound concrete repair mortar:</p> <p>"Betopox 012 WHG" granted and marked in acc. with the <i>allgemeine bauaufsichtliche Zulassung</i><sup>5)</sup> Z-74.12-85 (G)</p> <p>"Eurorepair PC 96 WHG" granted and marked in acc. with the <i>allgemeine bauaufsichtliche Zulassung</i><sup>5)</sup> Z-74.12-94 (G)</p> <p>"cde-Mörtel WHG" granted and marked in acc. with the <i>allgemeine bauaufsichtliche Zulassung</i><sup>5)</sup> Z-74.12-92 (G)</p> <p>"Proxan Reparaturmörtel PC 25" granted and marked in acc. with the <i>allgemeine bauaufsichtliche Zulassung</i><sup>5)</sup> Z-74.12-96 (G) and</p> <p>polymer modified cement-bound concrete repair mortar</p> <p>"SPCC Betonersatzsystem StoCrete TS 203" granted and marked in accordance with the <i>allgemeine bauaufsichtliche Zulassung</i><sup>5)</sup> Z-74.11-91 (G)</p> <p>for the use in facilities for the storage, handling and filling of substances hazardous to water</p>	<ul style="list-style-type: none"> <li>- according to the national provisions of the respective countries, which also include the specific requirements of the building authority and the law relating to water and are marked with the intended conformity marking in accordance with the national provisions of the respective countries.</li> </ul>
4	sealing constructions made of concrete <sup>4)</sup> : in-situ concrete with and without fibres	<ul style="list-style-type: none"> <li>- according to Annex 6, Table 1 and/or</li> <li>- according to the national provisions of the respective countries, which also include the specific requirements of the building authority and the law relating to water and are marked with the intended conformity marking in accordance with the national provisions of the respective countries.</li> </ul>
SABA Sealer 35 as a component of the joint sealing system of the SABA Dinxperlo BV used in facilities for storage, handling and filling of substances hazardous to water		Annex 5
Admissible contact materials		

<sup>1)</sup> e.g.: in G: mastic asphalt, granted and marked in accordance with the *allgemeine bauaufsichtliche Zulassung* ('national technical approval') (G) for mastic asphalt sealing layer for the use in facilities for the storage, handling and filling of substances hazardous to water

<sup>2)</sup> e.g.: vehicle pre-fabricated load-bearing elements made of liquid tight concrete granted and marked in accordance with an *allgemeine bauaufsichtliche Zulassung* ('national technical approval') (G) for the use in facilities for the storage, handling and filling of substances hazardous to water

<sup>3)</sup> e.g.: gutter (drains) made of fibre concrete, granted and marked in accordance with an *allgemeine bauaufsichtliche Zulassung* ('national technical approval') (G) for the use in facilities for the storage, handling and filling of substances hazardous to water

<sup>4)</sup> e.g.: liquid tight slabs made of in-situ concrete

<sup>5)</sup> 'national technical approval'

**Table 1:** Properties of the contact materials

No	Property	Characteristic value	Requirements (comments)
1	2	3	4
contact materials according to Annex 5, Table 1:			
1	migration behaviour	characteristic penetration depth, "e <sub>tk</sub> "	In accordance with the national requirements of the respective countries the characteristic penetration depth "e <sub>tk</sub> " (e <sub>tk</sub> = e <sub>i,m</sub> x 1.35) of the respective test liquid in the concrete has to be smaller than the joint side wall protected by the joint sealing compound (d <sub>H</sub> ), see also Annex 3; Figure 1.
In addition to concrete according to Annex 5, Table 1, No 2 and 4			
2	concrete strength	compressive strength class, C	≥ C30/37 ≤ C50/60 (EN 206-1, Table 7)
3	tightness	water/cement ratio, w/c	w/c ≤ 0.5 (EN 206-1, Table F.1)
In addition to fibre concrete <sup>1)</sup> according to Annex 5, Table 1, No 2 and 4:			
4	tightness	water/cement ratio, w/c	w/c < 0.45
5	fibres - kind - content - length	- volume, V length of fibre, l	- glass fibre - (0.5 ≤ V ≤ 5) vol.-% - l ≤ 25 mm

<sup>1)</sup> Only glass fibres may be used, which are marked with the conformity mark foreseen (e.g. in Germany *allgemeine bauaufsichtliche Zulassung* ('national technical approval')) according to national provisions of the respective Member States.

SABA Sealer 35 as a component of the joint sealing system of the SABA Dinxperlo BV used in facilities for storage, handling and filling of substances hazardous to water

Properties of the contact materials

Annex 6

**Table 1:** Admissible deformation distances for planning and design

No	Characteristic values/Notes	Admissible deformations as a result of extension, compressive strain and shear stress
	horizontal: <sup>2)</sup>	
1	<b>extension and compressive strain</b> and the sum resulting from extension, compressive strain in the area of parallel joint side walls and in the area of Tee and/or cruciform joints	10 mm joint width: 3.5 mm 20 mm joint width: 7.0 mm
	vertical: <sup>2)</sup>	
2	<b>shear</b> in the area of parallel joint side walls and in the area of Tee and cruciform joints	10 mm joint width: 3.5 mm 20 mm joint width: 7.0 mm
	resulting: <sup>1), 2)</sup>	
3	<b>Combination</b> of horizontal and vertical deformation in the area of parallel joint side walls and in the area of Tee and cruciform joints	10 mm joint width: 3.5 mm 20 mm joint width: 7.0 mm
4	The effect of the movement behaviour of the adjacent sealing construction (e.g. as a result of temperature, residual shrinkage or creep (concrete)) on the joint width is to be taken into account.	

- 1) **Simultaneous extension and/or compressive stress and shear:**  
Taking account of the real stresses, joint sealing compounds may be used placing more emphasis on the extension and/or compression capacity or on the shear capacity according to the following equation.

$$\frac{X_{DS,p}^2}{X_{DS}^2} + \frac{X_{S,p}^2}{X_S^2} \leq 1$$

with:

- X<sub>DS</sub>      admissible horizontal deformation
- X<sub>DS,p</sub>    extension distance and/or compressive strain distance to be expected (for planning)
- X<sub>S</sub>        admissible shear distance
- X<sub>S,p</sub>      shear distance to be expected (for planning)

- 2) Intermediate values are to be interpolated linear.

SABA Sealer 35 as a component of the joint sealing system of the SABA Dinxperlo BV used in facilities for storage, handling and filling of substances hazardous to water

Admissible deformation distances for planning and design

Annex 7

**Details of joint constructions for individual contact materials**

**Figure 1:**  
trafficable joint construction

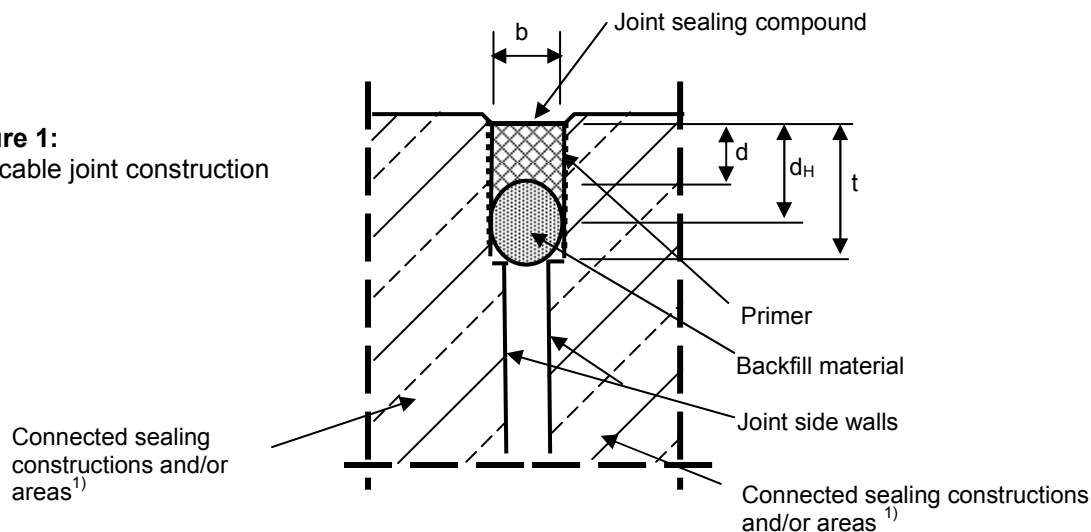

- <sup>1)</sup> Admissible contact materials:
- concrete
  - fibre concrete
  - certain concrete repair mortar (see Annex 5)

**Figure 2:**  
concrete / mastic asphalt<sup>1)</sup> (for pedestrian only)  
(acc. to Annex 5)

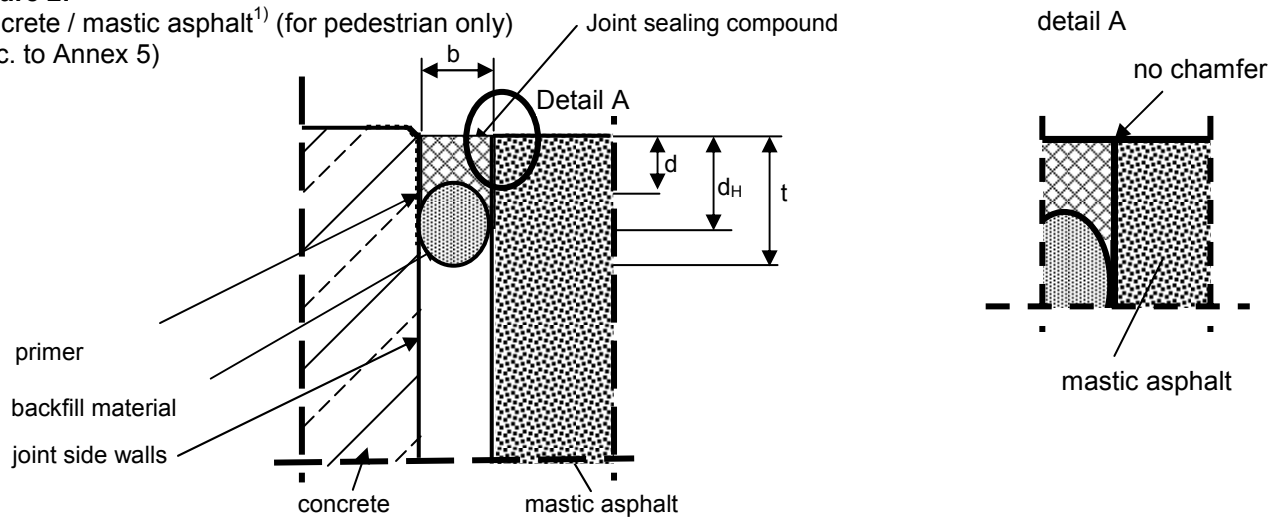

<sup>1)</sup> > 90 percent by weight mineral components

Electronic copy of the ETA by DIBt: ETA-12/0418

SABA Sealer 35 as a component of the joint sealing system of the SABA Dinxperlo BV used in facilities for storage, handling and filling of substances hazardous to water

Examples of joint constructions

Annex 8

<b>No</b>	<b>Confirmation by the executing company</b>	
1.	Project - Name..... - Size .....	
2.	storage substance: .....	
3.	Joint sealing system: <b>SABA Sealer 35, black or grey</b> as a component of the joint sealing system of the SABA Dinxperlo BV used in facilities for storage, handling and filling of substances hazardous to water	
4.	Approval: ETA-12/0418 dated on 30.04.2013	
5.a	Holder of the approval: SABA Dinxperlo B.V. Industriestraat 3 NL-7091 DC Dinxperlo Telefon: +31 (0) 315 / 65 89 99 Fax.: +31 (0) 315 / 65 89 89	
5.b	Name of company installing according to ..... ETA section 4.2.2 (1) and (2): .....	
5.c	Construction period: .....	
6.	The qualified personnel of the executing company was instructed by the holder of the European technical approval mentioned above in the proper processing.	Confirmation is on-hand: yes / no
7.	<b>Evaluations and controls before and during the installation of the joint sealing system</b>	
	a) Before the installation:	Note the characteristic values of the building side journal C ...../..... / w/c-ratio: .....
	- Compare concrete compressive strength class C ( $C_{30/37} \leq C \leq C_{50/60}$ ) and water-cement ratio ( $\leq 0.5$ ) with the documentation of the building side journal.	
	- joint width / joint distance / depth of the joint space in mm:	...../..... / .....
	- surface temperature / thawing temperature in °C:	...../.....
	- bond areas/contact areas are dry:	yes / no
	- bond areas/contact areas are free from all contaminations:	yes / no
	- system component in accordance with the approval:	yes / no
	- Marking of all components in accordance with the approval:	yes / no
	b) During and after the installation::	
	- Records of the weather conditions are enclosed:	yes / no
	- Visual test: (delete as applicable)	<input type="text" value="no objections"/> <input type="text" value="objections (see comments)"/>
	- side wall adhesion acc. to section 4.2.4(3): (delete as applicable)	<input type="text" value="no objections"/> <input type="text" value="objections (see comments)"/>
Remarks:		
	Date: .....	Signature / firm stamp
SABA Sealer 35 as a component of the joint sealing system of the SABA Dinxperlo BV used in facilities for storage, handling and filling of substances hazardous to water		Annex 9
Example of a confirmation by the executing company		



### Stress levels for the effective hourly capacity of water-contaminating substances

The level of chemical exposure shall be chosen in accordance with the following Tables 5.1 and 5.2. The Tables indicate the time and/or the frequency (period of exposure and frequency, respectively) as well as the appropriate time (test period) during which the test liquid (see list of test liquids) acts on the joint sealing compound (during the test).

The period of exposure shall be chosen by the manufacturer. Following successful performance testing, the characteristic technical values related to the respective stress level shall be specified in the approval.

**Table 5.1:** Stress level related to the period of stress during storage in a test liquid

Stress level 1	Description 2	Period of stress 3	Test period 4
<b>Storage (S)</b>			
<b>S<sub>1</sub></b>	low	up to 8 hours	8 hours
<b>S<sub>2</sub></b>	mean	up to 72 hours	72 hours

**Table 5.2:** Stress level related to the frequency of filling and/or handling period of test liquids

Stress level 1	Description 2	Period of stress 3	Test period 4
<b>Handling (H) and Filling (F)</b>			
<b>H<sub>1</sub>, F<sub>1</sub></b>	low	maximum of 4 times per year	8 hours
<b>H<sub>2</sub>, F<sub>2</sub></b>	mean	maximum of 200 times per year	72 hours

SABA Sealer 35 as a component of the joint sealing system of the SABA Dinxperlo BV used in facilities for storage, handling and filling of substances hazardous to water

Stress levels

Annex 10