



European Technical Approval ETA-13/0371

English translation prepared by DIBt - Original version in German language

Handelsbezeichnung
Trade name

Apolo MEA Schlaganker SA plus
Apolo MEA drop-in anchor SA plus

Zulassungsinhaber
Holder of approval

Apolo MEA Befestigungssysteme GmbH
Industriestraße 6
86551 Aichach
DEUTSCHLAND

Zulassungsgegenstand
und Verwendungszweck

Wegkontrolliert spreizender Dübel in den Größen M6, M8 und M10 für
die Verwendung als Mehrfachbefestigung von nichttragenden
Systemen in Beton

*Generic type and use
of construction product*

*Deformation-controlled expansion anchor in the size of M6, M8 and
M10 for multiple use for non-structural applications in concrete*

Geltungsdauer:
Validity: vom
from
bis
to

13 June 2013
13 June 2018

Herstellwerk
Manufacturing plant

-Werk 8
-Werk 13

Diese Zulassung umfasst
This Approval contains

15 Seiten einschließlich 7 Anhänge
15 pages including 7 annexes

I LEGAL BASES AND GENERAL CONDITIONS

- 1 This European technical approval is issued by Deutsches Institut für Bautechnik in accordance with:
 - Council Directive 89/106/EEC of 21 December 1988 on the approximation of laws, regulations and administrative provisions of Member States relating to construction products¹, modified by Council Directive 93/68/EEC² and Regulation (EC) N° 1882/2003 of the European Parliament and of the Council³;
 - *Gesetz über das In-Verkehr-Bringen von und den freien Warenverkehr mit Bauprodukten zur Umsetzung der Richtlinie 89/106/EWG des Rates vom 21. Dezember 1988 zur Angleichung der Rechts- und Verwaltungsvorschriften der Mitgliedstaaten über Bauprodukte und anderer Rechtsakte der Europäischen Gemeinschaften (Bauproduktengesetz - BauPG) vom 28. April 1998⁴, as amended by Article 2 of the law of 8 November 2011⁵;*
 - Common Procedural Rules for Requesting, Preparing and the Granting of European technical approvals set out in the Annex to Commission Decision 94/23/EC⁶;
 - Guideline for European technical approval of "Metal anchors for use in concrete - Part 6: Anchors for multiple use for non-structural applications", ETAG 001-06.
- 2 Deutsches Institut für Bautechnik is authorized to check whether the provisions of this European technical approval are met. Checking may take place in the manufacturing plant. Nevertheless, the responsibility for the conformity of the products to the European technical approval and for their fitness for the intended use remains with the holder of the European technical approval.
- 3 This European technical approval is not to be transferred to manufacturers or agents of manufacturers other than those indicated on page 1, or manufacturing plants other than those indicated on page 1 of this European technical approval.
- 4 This European technical approval may be withdrawn by Deutsches Institut für Bautechnik, in particular pursuant to information by the Commission according to Article 5(1) of Council Directive 89/106/EEC.
- 5 Reproduction of this European technical approval including transmission by electronic means shall be in full. However, partial reproduction can be made with the written consent of Deutsches Institut für Bautechnik. In this case partial reproduction has to be designated as such. Texts and drawings of advertising brochures shall not contradict or misuse the European technical approval.
- 6 The European technical approval is issued by the approval body in its official language. This version corresponds fully to the version circulated within EOTA. Translations into other languages have to be designated as such.

¹ Official Journal of the European Communities L 40, 11 February 1989, p. 12
² Official Journal of the European Communities L 220, 30 August 1993, p. 1
³ Official Journal of the European Union L 284, 31 October 2003, p. 25
⁴ *Bundesgesetzblatt Teil I 1998*, p. 812
⁵ *Bundesgesetzblatt Teil I 2011*, p. 2178
⁶ Official Journal of the European Communities L 17, 20 January 1994, p. 34

II SPECIFIC CONDITIONS OF THE EUROPEAN TECHNICAL APPROVAL

1 Definition of product and intended use

1.1 Definition of the construction product

The Apolo MEA Drop-In Anchor SA plus in sizes M6, M8 and M10 is an anchor made of zinc-plated steel which is placed into a drilled hole and anchored by deformation-controlled expansion.

The product (types, sizes) and an illustration of the installed anchor is given in Annex 1.

The fixture shall be anchored with a fastening screw or threaded rod according to Annex 4.

1.2 Intended use

The anchor is intended to be used for anchorages for which requirements for safety in use in the sense of the Essential Requirements 4 of Council Directive 89/106 EEC shall be fulfilled and failure of the fixture represents an immediate risk to human life. The anchor is to be used only for multiple use for non-structural applications. The definition of multiple use according to the Member States is given in the informative Annex 1 of ETAG 001, Part 6.

The anchor may be used for anchorages with requirements related to resistance to fire.

The anchor is to be used only for anchorages subject to static or quasi-static loading in reinforced or unreinforced normal weight concrete of strength classes C20/25 at minimum and C50/60 at most according to EN 206:2000-12.

The anchor may be used in cracked and non-cracked concrete.

The anchor may only be used in structures subject to dry internal conditions.

The provisions made in this European technical approval are based on an assumed working life of the anchor of 50 years. The indications given on the working life cannot be interpreted as a guarantee given by the producer, but are to be regarded only as a means for choosing the right products in relation to the expected economically reasonable working life of the works.

2 Characteristics of product and methods of verification

2.1 Characteristics of product

The anchor corresponds to the drawings and provisions given in Annex 2. The characteristic material values, dimensions and tolerances of the anchor not given in Annex 2 shall correspond to the respective values laid down in the technical documentation⁷ of this European technical approval.

⁷ The technical documentation of this European technical approval is deposited at the Deutsches Institut für Bautechnik and, as far as relevant for the tasks of the approved bodies involved in the attestation of conformity procedure, is handed over to the approved bodies.

Regarding the requirements concerning safety in case of fire it is assumed that the anchor meets the requirements of class A1 in relation to reaction to fire in accordance with the stipulations of the Commission decision 96/603/EC, amended by 2000/605/EC.

The characteristic values for the design of anchorages are given in Annex 5, Table 6.

The characteristic anchor values for the design of the anchorages regarding resistance to fire are given in Annex 6, Table 7. They are valid for use in a system that is required to provide a specific fire resistance class.

Each anchor is marked with the identifying mark of the producer, the anchor identity and the thread size according to Annex 1.

The anchor shall only be packaged and supplied as a complete unit.

2.2 Methods of verification

The assessment of fitness of the anchor for the intended use in relation to the requirements for safety in use in the sense of the Essential Requirements 4 has been made in accordance with the "Guideline for European technical approval of Metal Anchors for use in concrete", Part 1 "Anchors in general" and Part 6 "Anchors for multiple use for non-structural applications".

The assessment of the anchor for the intended use in relation to the requirements for resistance to fire has been made in accordance with the Technical Report TR 020 "Evaluation of anchorages in concrete concerning resistance to fire".

In addition to the specific clauses relating to dangerous substances contained in this European technical approval, there may be other requirements applicable to the products falling within its scope (e.g. transposed European legislation and national laws, regulations and administrative provisions). In order to meet the provisions of the Construction Products Directive, these requirements need also to be complied with, when and where they apply.

3 Evaluation and attestation of conformity and CE marking

3.1 System of attestation of conformity

According to the decision 97/161/EG of the European Commission⁸ the system 2(ii) (referred to as system 2+) of attestation of conformity applies.

This system of attestation of conformity is defined as follows:

System 2+: Declaration of conformity of the product by the manufacturer on the basis of:

- (a) Tasks for the manufacturer:
 - (1) initial type-testing of the product;
 - (2) factory production control;
 - (3) testing of samples taken at the factory in accordance with a prescribed control plan.

- (b) Tasks for the approved body:
 - (4) certification of factory production control on the basis of:
 - initial inspection of factory and of factory production control;
 - continuous surveillance, assessment and approval of factory production control.

Note: Approved bodies are also referred to as "notified bodies".

⁸ Official Journal of the European Communities L 67 of 03.02.1997

3.2 Responsibilities

3.2.1 Tasks of the manufacturer

3.2.1.1 Factory production control

The manufacturer shall exercise permanent internal control of production. All the elements, requirements and provisions adopted by the manufacturer shall be documented in a systematic manner in the form of written policies and procedures, including records of results performed. This production control system shall insure that the product is in conformity with this European technical approval.

The manufacturer may only use initial / raw / constituent materials stated in the technical documentation of this European technical approval.

The factory production control shall be in accordance with the control plan which is part of the technical documentation of this European technical approval. The control plan is laid down in the context of the factory production control system operated by the manufacturer and deposited at Deutsches Institut für Bautechnik.⁹

The results of factory production control shall be recorded and evaluated in accordance with the provisions of the control plan.

3.2.1.2 Other tasks of manufacturer

The manufacturer shall, on the basis of a contract, involve a body which is approved for the tasks referred to in section 3.1 in the field of the anchor in order to undertake the actions laid down in section 3.3. For this purpose, the control plan referred to in sections 3.2.1.1 and 3.2.2 shall be handed over by the manufacturer to the approved body involved.

The manufacturer shall make a declaration of conformity, stating that the construction product is in conformity with the provisions of this European technical approval.

3.2.2 Tasks of approved bodies

The approved body shall perform the following tasks in accordance with the provisions laid down in the control plan:

- initial inspection of factory and of factory production control,
- continuous surveillance, assessment and approval of factory production control.

The approved body shall retain the essential points of its actions referred to above and state the results obtained and conclusions drawn in a written report.

The approved certification body involved by the manufacturer shall issue an EC certificate of conformity of the factory production control stating the conformity with the provisions of this European technical approval.

In cases where the provisions of the European technical approval and its control plan are no longer fulfilled the certification body shall withdraw the certificate of conformity and inform Deutsches Institut für Bautechnik without delay.

⁹ The control plan is a confidential part of the European technical approval and only handed over to the approved body involved in the procedure of attestation of conformity. See section 3.2.2.

3.3 CE marking

The CE marking shall be affixed on each packing of the anchor. The letters "CE" shall be followed by the identification number of the approved certification body, where relevant, and be accompanied by the following additional information:

- the name and address of the producer (legal entity responsible for the manufacture),
- the last two digits of the year in which the CE marking was affixed,
- the number of the EC certificate for the factory production,
- the number of the European technical approval,
- the number of the guideline for European technical approval,
- use category (ETAG 001-6),
- size.

4 Assumptions under which the fitness of the product for the intended use was favourably assessed

4.1 Manufacturing

The European technical approval is issued for the product on the basis of agreed data/information, deposited with Deutsches Institut für Bautechnik, which identifies the product that has been assessed and judged. Changes to the product or production process, which could result in this deposited data/information being incorrect, should be notified to Deutsches Institut für Bautechnik before the changes are introduced. Deutsches Institut für Bautechnik will decide whether or not such changes affect the European technical approval and consequently the validity of the CE marking on the basis of the European technical approval and if so whether further assessment or alterations to the European technical approval shall be necessary.

4.2 Design of anchorages

The fitness of the anchor for the intended use is given under the following conditions:

The anchorages are designed in accordance with the "Guideline for European technical approval of Metal Anchors for Use in Concrete", Annex C, Method B, under the responsibility of an engineer experienced in anchorages and concrete work.

Verifiable calculation notes and drawings are prepared taking account of the loads to be anchored.

The position of the anchor is indicated on the design drawings (e.g. position of the anchor relative to reinforcement or to supports).

The strength class and the length of the fastening screw or threaded rod shall be defined by the designing engineer. The choice of the length shall account for the available thread length, the minimum screwing depth, the thickness of fixture and tolerances of member and fixture. The strength class and the minimum screwing depth of the fastening screw or threaded rod shall be met the requirements according to Annex 4.

The design of anchorages under fire exposure has to consider the conditions given in the Technical Report TR 020 "Evaluation of anchorages in concrete concerning resistance to fire". The relevant characteristic values are given in Annex 6, Table 6. The design method covers anchors with a fire attack from one side only. If the fire attack is from more than one side, the design method may be taken only, if the edge distance of the anchor is $c \geq 300$ mm.

Local spalling is possible at fire attack. To avoid any influence of the spalling on the anchorage, the concrete member must be designed according to prEN 1992-1-2. The members shall be made of concrete with quartzite additives and have to be protected from direct moisture; and the moisture content of the concrete has to be like in dry internal conditions respectively. The anchorage depth has to be increased for wet concrete by at least 30 mm compared to the given value in the approval.

4.3 Installation of anchors

The fitness for use of the anchor can only be assumed if the anchor is installed as follows:

- Anchor installation carried out by appropriately qualified personnel and under the supervision of the person responsible for technical matters of the site.
- Use of the anchor only as supplied by the manufacturer without exchanging the components of an anchor.
- Anchor installation in accordance with the manufacturer's specifications and drawings and using the appropriate tools.
- Checks before placing the anchor to ensure that the strength class of the concrete in which the anchor is to be placed is in the range given and is not lower than that of the concrete to which the characteristic loads apply.
- Check of concrete being well compacted, e.g. without significant voids.
- Edge distances and spacing not less than the specified values without minus tolerances.
- Positioning of the drill holes without damaging the reinforcement.
- In case of aborted hole: new drilling at a minimum distance away of twice the depth of the aborted hole or smaller distance if the aborted drill hole is filled with high strength mortar and if under shear or oblique tension load it is not in the direction of load application.
- Cleaning of the hole of drilling dust.
- Anchor installation according to manufacturer's instructions given in Annex 7.
- Anchor expansion by impact on the cone using the setting tools given in Annex 3. The anchor is properly set if the stop of the setting tool reaches the expansion sleeve.
- The fastening screw or threaded rod shall correspond to the requirements given in Annex 4.
- Installation torque moments are not required for functioning of the anchor. However, the torque moments given in Annex 4 must not be exceeded.

5 Responsibility of the manufacturer

The manufacturer is responsible to ensure that the information on the specific conditions according to 1 and 2 including Annexes referred to as well as sections 4.2 and 4.3 is given to those who are concerned. This information may be made by reproduction of the respective parts of the European technical approval. In addition all installation data shall be shown clearly on the package and/or on an enclosed instruction sheet, preferably using illustration(s).

The minimum data required are:

- drill bit diameter,
- thread diameter,
- minimum effective anchorage depth,
- available thread length and minimum screwing depth of the fastening screw or threaded rod,
- minimum hole depth,
- torque moment,
- information on the installation procedure, including cleaning of the hole, preferably by means of an illustration,
- reference to any special installation equipment needed,
- identification of the manufacturing batch.

All data shall be presented in a clear and explicit form.

Andreas Kummerow
p. p. Head of Department

beglaubigt:
Tempel

Apolo MEA Drop in anchor SA plus

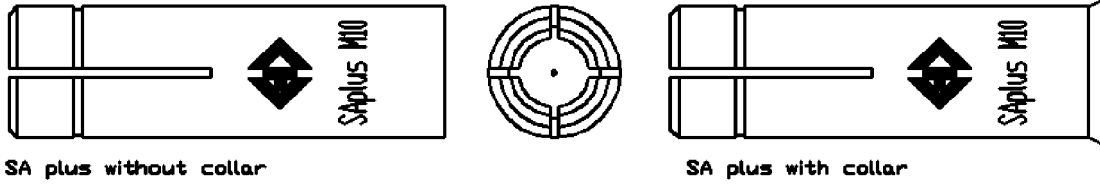

marking: brand marking Logo or company
 type SA plus
 size M ... (i.e. M10)

Example:  SA plus M10

SA plus after installation in cracked concrete C20/25 – C50/60

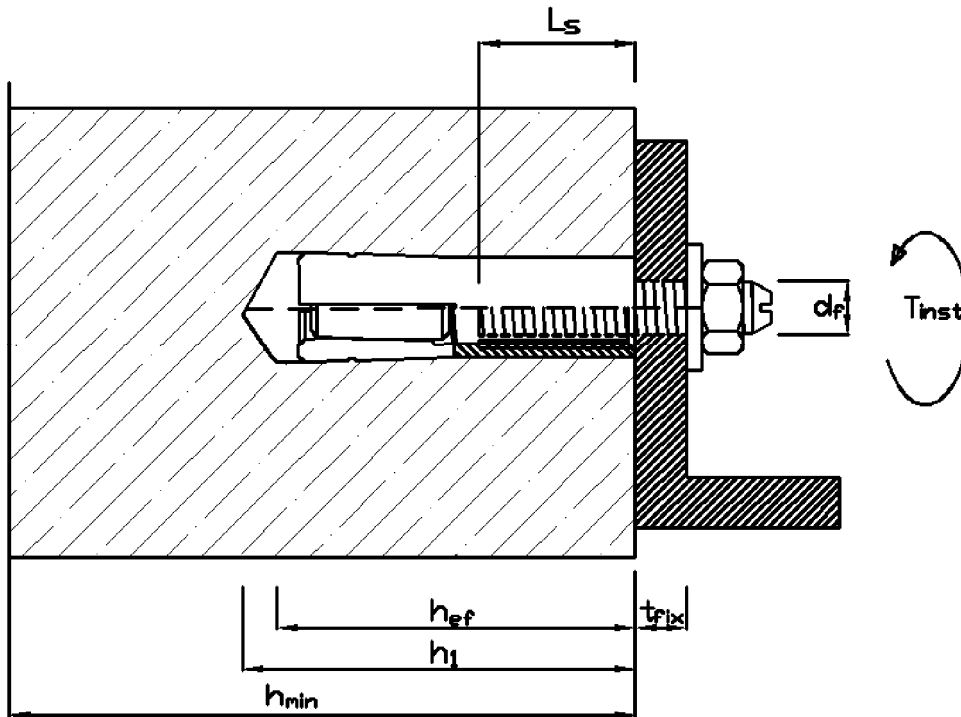

- h_1 = depth of drill hole
- h_{ef} = effective anchorage depth
- t_{fix} = thickness of fixture
- L_s = length of thread inside of the anchor
- T_{inst} = max. installation torque

Apolo MEA Drop in anchor SA plus

Product, marking and intended use

Annex 1

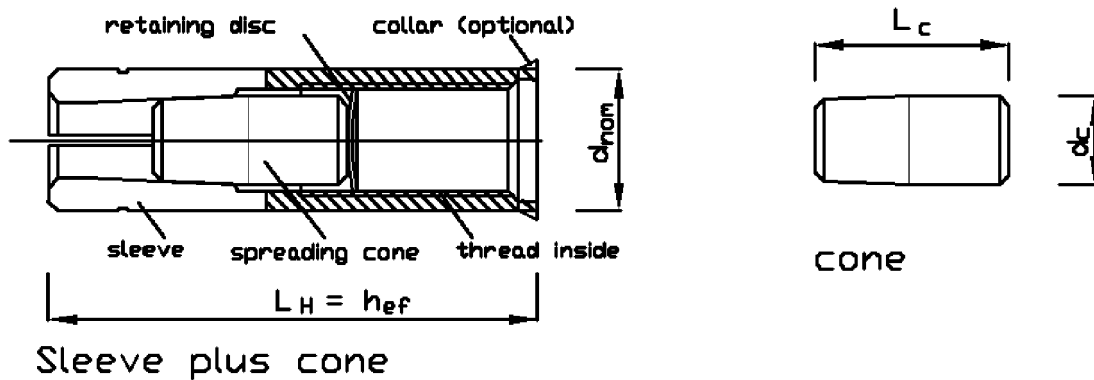

Table 1: Parts and materials

Designation	Material
sleeve M6, M8	steel for cold forming C1008-C1012 or EN 10277
sleeve M10	steel for cold forming C1015 or EN 10277
spreading cone	steel for cold forming C1006-1008
retaining disc	paper or plastics

all parts zinc plated and blue passivated $\geq 5 \mu\text{m}$ acc. EN ISO 4042

Table 2: Dimensions

Anchor		Sleeve		Cone	
	thread inside	length	outer-Ø sleeve	length	outer-Ø cone
type		L_s	d_{nom}	L_c	d_c
SA plus		[mm]	[mm]	[mm]	[mm]
M 6 x 25	M6	25	8	10	4,5
M 8 x 30	M8	30	10	12	6
M10 x 40	M10	40	12	16	7,5

Apolo MEA Drop in anchor SA plus

Parts, materials and anchor dimensions

Annex 2

Handsetting tool

Optional: setting tool with marking and/or rubber grip possible

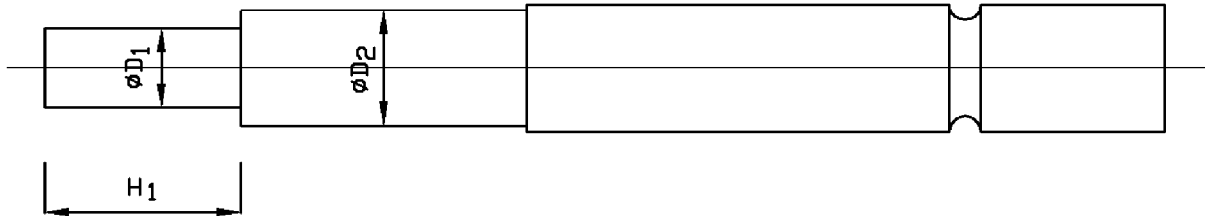

Table 3: Geometry of the setting tool

Setting tool	Setting pin		
steel HRc 38-42	dimension		
Type	D ₁	D ₂	H ₁
	[mm]	[mm]	[mm]
ESW 6	5	7,5	15
ESW 8	6,6	9,5	17,5
ESW 10	8,3	12	23,5

Apolo MEA Drop in anchor SA plus

Setting tool

Annex 3

Table 4: Installation data

Fixing screws or anchor rods:

It can be used the strength categories 4.6, 5.6, 5.8 or 8.8 acc. EN ISO 898-1.

Minimal screwing depth:

The length of the fixing screw depends on the thickness t_{fix} on the fixed part, permissible tolerances and usable thread length $L_{s,max}$ as well as on the minimal screwing depth $L_{s,min}$.

Apolo MEA drop in anchor SA plus			size		
			M6	M8	M10
nominal driller diameter	d_0	[mm]	8	10	12
Cutting diameter of drillbit	$d_{cut} \leq$	[mm]	8,45	10,45	12,50
diameter of thread inside	M	[mm]	6	8	10
depth of drill hole (deepest point)	$h_1 \geq$	[mm]	27	32	43
effective anchorage depth	h_{ef}	[mm]	25	30	40
Maximum screwing depth	$L_{s,max}$	[mm]	11	13	16
Minimum screwing depth	$L_{s,min}$	[mm]	6	8	10
diameter of clearance hole in the fixture	$d_f \leq$	[mm]	7	9	12
Maximum installation torque moment	$\max T_{inst}$	[Nm]	4	8	15

Table 5: Minimum thickness of concrete member, spacing and edge distance

Apolo MEA drop in anchor SA plus			Size		
			M6	M8	M10
minimum thickness of member	h_{min}	[mm]	100	100	100
minimum spacing	s_{min}	[mm]	70	105	105
minimum edge distance	c_{min}	[mm]	105	105	140

Apolo MEA Drop in anchor SA plus

Installation data
Minimum spacing and edge distances

Annex 4

Table 6: Design method B - Characteristic load values

Apolo MEA drop in anchor SA plus				Size		
Any load direction				M6	M8	M10
Characteristic resistance in concrete C20/25 - C 50/60	F_{RK}^0	[kN]	≥ Steel 4.6	1,5	3,0	7,5
partial safety factor	$\gamma_{Ms}^{1)}$	[-]		2,1 ²⁾	1,8 ²⁾	
Characteristic spacing	s_{cr}	[mm]		80	120	240
Characteristic edge distance	c_{cr}	[mm]		40	60	120
Steel failure with lever arm						
Characteristic bending moment	$M_{RK,S}^0$ ³⁾	[Nm]	Steel 4.6	6,1	15,0	29,9
partial safety factor	$\gamma_{Ms}^{1)}$	[-]		1,67		
Characteristic bending moment	$M_{RK,S}^0$ ³⁾	[Nm]	Steel 5.6	7,6	37,4	65,5
partial safety factor	$\gamma_{Ms}^{1)}$	[-]		1,67		
Characteristic bending moment	$M_{RK,S}^0$ ³⁾	[Nm]	Steel 5.8	7,6	37,4	65,5
partial safety factor	$\gamma_{Ms}^{1)}$	[-]		1,25		
Characteristic bending moment	$M_{RK,S}^0$ ³⁾	[Nm]	Steel 8.8	12,2	30,0	59,8
partial safety factor	$\gamma_{Ms}^{1)}$	[-]		1,25		

1) In absence of other national regulations

2) The installation safety factor of γ_2 is included

3) Characteristic bending moment for equation 5.5 in ETAG 001, Annex C

Apolo MEA Drop in anchor SA plus

Design method B:
Characteristic values

Annex 5

**Table 7: Characteristic resistance under fire exposure in any load direction
for use in concrete C20/25 – C50/60**

Apolo MEA drop in anchor SA plus					size		
Fire resistance class					M6	M8	M10
R 30	Characteristic resistance	$F_{Rk,fi}$	[kN]	\geq Steel 4.6	0,2	0,3	0,6
R 60	Characteristic resistance	$F_{Rk,fi}$	[kN]	\geq Steel 4.6	0,2	0,3	0,5
R 90	Characteristic resistance	$F_{Rk,fi}$	[kN]	\geq Steel 4.6	0,2	0,2	0,4
R 120	Characteristic resistance	$F_{Rk,fi}$	[kN]	\geq Steel 4.6	0,1	0,2	0,3
Spacing and edge distance under fire exposure							
Spacing distance for R 30 – R 120		$S_{cr,fi}$	[mm]		100	120	160
Edge distance for R 30 – R 120		$C_{cr,fi}$	[mm]		50	60	80
The edge distance shall be ≥ 300 mm, in case of fire attack from more than one side.							

¹⁾ In absence of other national regulations the partial safety factor for resistance under fire exposure $\gamma_{m,fi} = 1,0$ is recommended.

Apolo MEA Drop in anchor SA plus

Characteristic values under fire exposure

Annex 6

Installation instruction of the Apolo MEA drop in anchor SA plus



1. Drill the hole with a hammer drill

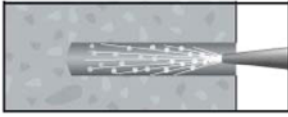

2. Clean the borehole

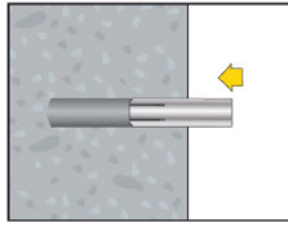

3. To set the anchor by hand or by hammer blows, anchor should be flush to the concrete edge

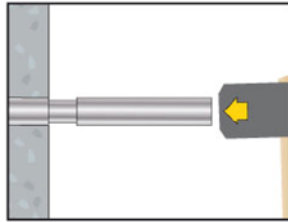

4. To spread the anchor with the setting tool. The anchor is installed correctly, if the setting pin is completely inside

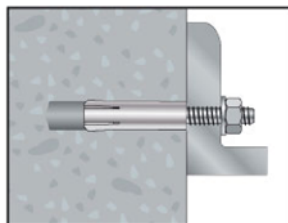

5. To fix the fixture, not allowed to pass over the max. installation torque T_{inst}