



## European Technical Approval ETA-13/0499

English translation prepared by DIBt - Original version in German language

Handelsbezeichnung  
*Trade name*

"Baureihe 104 EU"  
*"Type series 104 EU"*

Zulassungsinhaber  
*Holder of approval*

gte Holding AG  
Hamburger Straße 2  
14532 Stahnsdorf  
DEUTSCHLAND

Zulassungsgegenstand  
und Verwendungszweck

Feuerschutzabschluss "Baureihe 104 EU" im Zuge von  
bahngebundenen Förderanlagen  
Verwendung als Abschluss für Wandöffnungen von bahngebundenen  
Förderanlagen; im Schließbereich nicht getrennte Fördertechnik  
(Rollen-, Ketten- und Gurtförderer)

*Generic type and use  
of construction product*

*Kit for a closure system "Type series 104 EU" for conveyor systems*

Geltungsdauer:  
*Validity:* vom  
from

23 May 2013

bis  
to

23 May 2018

Herstellwerk  
*Manufacturing plant*

gte Brandschutz AG  
Hamburger Straße 2  
14532 Stahnsdorf  
DEUTSCHLAND

Diese Zulassung umfasst  
*This Approval contains*

15 Seiten einschließlich 5 Anhänge  
*15 pages including 5 annexes*

## I LEGAL BASES AND GENERAL CONDITIONS

- 1 This European technical approval is issued by Deutsches Institut für Bautechnik in accordance with:
  - Council Directive 89/106/EEC of 21 December 1988 on the approximation of laws, regulations and administrative provisions of Member States relating to construction products<sup>1</sup>, modified by Council Directive 93/68/EEC<sup>2</sup> and Regulation (EC) N° 1882/2003 of the European Parliament and of the Council<sup>3</sup>;
  - *Gesetz über das In-Verkehr-Bringen von und den freien Warenverkehr mit Bauprodukten zur Umsetzung der Richtlinie 89/106/EWG des Rates vom 21. Dezember 1988 zur Angleichung der Rechts- und Verwaltungsvorschriften der Mitgliedstaaten über Bauprodukte und anderer Rechtsakte der Europäischen Gemeinschaften (Bauproduktengesetz - BauPG) vom 28. April 1998<sup>4</sup>, as amended by Article 2 of the law of 8 November 2011<sup>5</sup>;*
  - Common Procedural Rules for Requesting, Preparing and the Granting of European technical approvals set out in the Annex to Commission Decision 94/23/EC<sup>6</sup>.
- 2 Deutsches Institut für Bautechnik is authorized to check whether the provisions of this European technical approval are met. Checking may take place in the manufacturing plant. Nevertheless, the responsibility for the conformity of the products to the European technical approval and for their fitness for the intended use remains with the holder of the European technical approval.
- 3 This European technical approval is not to be transferred to manufacturers or agents of manufacturers other than those indicated on page 1, or manufacturing plants other than those indicated on page 1 of this European technical approval.
- 4 This European technical approval may be withdrawn by Deutsches Institut für Bautechnik, in particular pursuant to information by the Commission according to Article 5(1) of Council Directive 89/106/EEC.
- 5 Reproduction of this European technical approval including transmission by electronic means shall be in full. However, partial reproduction can be made with the written consent of Deutsches Institut für Bautechnik. In this case partial reproduction has to be designated as such. Texts and drawings of advertising brochures shall not contradict or misuse the European technical approval.
- 6 The European technical approval is issued by the approval body in its official language. This version corresponds fully to the version circulated within EOTA. Translations into other languages have to be designated as such.

<sup>1</sup> Official Journal of the European Communities L 40, 11 February 1989, p. 12  
<sup>2</sup> Official Journal of the European Communities L 220, 30 August 1993, p. 1  
<sup>3</sup> Official Journal of the European Union L 284, 31 October 2003, p. 25  
<sup>4</sup> *Bundesgesetzblatt Teil I 1998*, p. 812  
<sup>5</sup> *Bundesgesetzblatt Teil I 2011*, p. 2178  
<sup>6</sup> Official Journal of the European Communities L 17, 20 January 1994, p. 34

## II SPECIFIC CONDITIONS OF THE EUROPEAN TECHNICAL APPROVAL

### 1 Definition of the product and intended use

#### 1.1 Definition of the construction product

This European technical approval applies for the closure system "Type series 104 EU" for conveyor systems, hereinafter referred to as "Type series 104 EU". The closure system can be designed for installation at floor level or for installation at raised position.

"Type series 104 EU" primarily consists of the following components<sup>7</sup>:

- Single-leaf flap leaf  
The approx. 48 mm thick flap leaf consists of an inner framework of steel hollow profiles (30 mm x 20 mm x 2 mm), filled with a 30 mm thick calcium silicate board and both-sided covered with a 9 mm thick calcium silicate board. The sliding leaf may be covered with ≤ 1 mm thick steel plate or wood veneer. The calcium silicate boards are secured with water glass adhesive and steel cramps.  
The flap leaf is fixed to the wall by a L steel section (60 mm x 60 mm x 6 mm) and steel hinges. Wall covering of the flap leaf at the side and at the top amounts to 100 mm.
- Fixed panel with clearance for the conveyor  
The 170 mm thick fixed panel consists of several calcium silicate boards or gypsum boards which are secured with water glass adhesive. The fixed panel is secured to the wall via brackets. The clearance in the fixed panel is configured for the respective conveyor technology. Various intumescent materials are used in the necessary functional gaps.
- Wall frame and locking device of the flap leaf  
The closed flap leaf is enclosed by a wall frame of L steel sections (60 mm x 40 mm x 5 mm). The flap leaf will be locked by two locking devices on the wall frame.
- Seal system  
In the overlap of the flap leaf and adjacent wall on the side of the flap leaf facing the wall strips of an intumescent material are positioned (see annex 3).  
On the lower edge of the flap leaf a sealing segment with strips of an intumescent material is positioned above the conveyor system. Strips of an intumescent material are positioned in the conveyor technology area in the fixed panel (see annex 4).  
The sealing segments on the flap leaf consist of several strips of calcium silicate board. The fixed panel in the conveyor technology area consist of several strips of calcium silicate board or gypsum board. Strips of an intumescent material must be positioned in the residual gaps.

<sup>7</sup> The documents describing the structure of "Type series 104 EU" in detail and the product specifications of the building materials used are deposited with DIBt.

- Closing device (closing weight system)  
"Type series 104 EU" shall be closed via stored mechanical energy (deadweight of the flap leaf).

## 1.2 Intended use

In accordance with this European technical approval, the "Type series 104 EU" can be used as closure to seal necessary openings of trackbound conveyors (chain, roller and belt conveyors) in internal walls (see table 1).

When used, in particular the permitted service conditions of the intumescent materials used are to be observed.

Table 1: Permitted dimensions of the clearance of the component opening

Component (supporting construction) in which the closure can be installed <sup>a)</sup>	Maximum fire resistance class <sup>b)</sup>	Clearance of the component opening		
		clear width	clear height	Maximum surface
High-density solid wall Masonry or solid concrete with an overall density of $\geq 800 \text{ kg/m}^3$ and a thickness $\geq 175 \text{ mm}$	E 90 EI <sub>2</sub> 90 EW 60	min. 500 max. 1.500	min. 500 max. 1.500	2,25 m <sup>2</sup>
Low-density solid wall Aerated concrete with an overall density of $\geq 450 \text{ kg/m}^3$ and a thickness $\geq 175 \text{ mm}$	E 90 EI <sub>2</sub> 90 EW 60	min. 500 max. 1.500	min. 500 max. 1.500	2,25 m <sup>2</sup>

a) Supporting construction to EN 1366-7<sup>8</sup>, section 7.2 or EN 1363-1<sup>9</sup>, section 7.2  
b) Fire resistance class per EN 13501-2<sup>10</sup> in accordance with the Evaluation Report

In order to seal the continuous conveyor technology, the sealing systems specified in table 2 can be used.

Table 2: Permitted sealing systems for the continuous conveyor technology<sup>11</sup>

Sealing system for	Fixed panel thickness (gypsum cardboard)	Minimum penetration seal depth of the seal on the fixed panel (calcium silicate boards)	Minimum penetration seal depth of the sealing segment on the sliding leaf (calcium silicate boards)	Maximum fire resistance class
Roll conveyor	170 mm	170 mm Between the rollers: 2 x 20 mm webs	76 mm	EI 90
Belt conveyor	170 mm	170 mm	76 mm	EI 90
Chain conveyor	170 mm	170 mm	76 mm	EI 90

<sup>8</sup> EN 1366-7:2004 Fire resistance tests for service installations - Part 7: Conveyor systems and their closures

<sup>9</sup> EN 1363-1:1999 Fire resistance tests - Part 1: General requirements

<sup>10</sup> EN 13501-2:2007 Fire classification of construction products and building elements - Part 2: Classification using data from fire resistance tests, excluding ventilation services

<sup>11</sup> see Annex 4

The conveyor tracks shall be positioned at the bottom and can be continuous or disconnected or disconnected while closing of the closure in the closing area of the sliding leaf.

The "Type series 104 EU" shall only be used if the following conditions apply:

- The normally-open closure (open in the normal position; closes in the event of a fire; see section 2.1.2) shall be equipped with a hold-open system suitable for the closure – where applicable in conjunction with the national regulations.
- The normally-open closure, which cannot be opened from a fixed position (floor, pedestal etc.), is to be equipped with a drive to open the closure.
- It is to be ensured that the closing of the closure is not obstructed by conveyed goods or other objects.
- It is to be ensured that the closed closure cannot be damaged by conveyed goods or other objects.

The conditions of this European technical approval are based on an assumed working life of the "Baureihe 104 EU" of 10 years, provided the conditions for packaging, transport, storage, installation, use, maintenance and repair specified in sections 4.2, 5.1/5.2 are fulfilled.

The indications given on the working life cannot be interpreted as a guarantee given by the manufacturer, but are to be regarded only as a means for choosing the right products in relation to the expected economically reasonable working life of the works.

WARNING - Other requirements and other EU Directives may be applicable to the product(s) falling within the scope of this document.

## 2 Characteristics of the product and methods of verification

### 2.1 Characteristics of the assembled system and method of verification

#### 2.1.1 Fire resistance

The fire resistance was determined in accordance with EN 1366-7<sup>8</sup>. The fire resistance classes specified in section 1.2 were verified in accordance with EN 13501-2<sup>10</sup>.

#### 2.1.2 Durability

The durability was determined in accordance with EN 14600<sup>12</sup>. The closure systems were tested through 200,000 cycles. For the closure system class C5 was demonstrated.

The drive belts and deflection rollers, as well as the hinges shall be selected in accordance with the load bearing capacity specifications of the manufacturer for the weight of the flap leaf.

#### 2.1.3 Content and/or release of dangerous substances

The closure system "Type series 104 EU" does not contain/release any dangerous substances specified in TR 034<sup>13</sup>.

#### 2.1.4 Closing speed

The closing speed on the closing device shall be set such that compliance with the requirements per EN 14600<sup>12</sup> is ensured.

<sup>12</sup> EN 14600:2005 Doorsets and openable windows with fire resisting and/or smoke control characteristics - Requirements and classification

<sup>13</sup> TR 034 General ER 3 Checklist for ETAGs/CUAPs/ETAs - Content and/or release of dangerous substances in products/kits

### 2.1.5 Closing and opening force

The applicant for this European technical approval shall specify the closing and opening force of the closure. The personal health and safety requirements per EN 12453<sup>14</sup> were not verified.

## 2.2 Characteristics of the components of the system and method of verification

### 2.2.1 Moving flap leaf and fixed panel with clearance for the conveyor

Reaction to fire<sup>7</sup>

The steel profiles and the steel sheet of the flap leaf were classified for their reaction to fire in accordance with Decision 96/603/EC of the European Commission<sup>15</sup> (as amended) as Class A1 per EN 13501-1<sup>16</sup>.

The gypsum cardboard used for the fixed panel were classified for their reaction to fire in accordance with Decision 2006/673/EC of the European Commission<sup>17</sup> as Class A1 per EN 13501-1<sup>16</sup>.

The Calcium silicate boards were classified as Class A1 per EN 13501-1<sup>16</sup> for their reaction to fire.

The water glass adhesive fulfils at least the requirements for reactions to fire of Class E materials per EN 13501-1<sup>16</sup>.

### 2.2.2 Wall frame and hinges of the flap leaf

Reaction to fire<sup>7</sup>

The L sections of the wall frame and the hinges are made of steel. Per Decision 96/603/EC of the European Commission<sup>15</sup> (as amended), steel satisfy the requirements in accordance with fire resistance class A1 per EN 13501-1<sup>16</sup>.

### 2.2.3 Sealing system consisting of intumescent material

#### 2.2.3.1 Reaction to fire<sup>7</sup>

The intumescent material Promaseal PL, which is used for the sealing system, fulfils at least the requirements for reactions to fire of Class E materials per EN 13501-1<sup>16</sup>.

#### 2.2.3.2 Expansion ratio and expansion pressure of intumescent material after aging

The characteristics and the fire performance criteria of the intumescent material used were determined after loading and are deposited with DIBt.

#### 2.2.3.3 Identification

The intumescent material used as a sealing system can be identified via their thickness, density and their expansion ratio as well as via their ash content and expansion pressure in accordance with the methods specified in section 5.2 of CUAP 11.07/02. A fingerprint and the chemical composition are deposited with DIBt for the intumescent materials.

### 2.2.4 Closing device

#### 2.2.4.1 Reaction to fire

The brackets for fastening of the opening device and the hold-open system as well as the locking device are made of steel.

Per Decision 96/603/EC of the European Commission<sup>15</sup> (as amended), steel and steel sheet satisfy the requirements in accordance with fire resistance class A1 per EN 13501-1<sup>16</sup>.

<sup>14</sup> EN 12453:2000 Industrial, commercial and garage doors and gates - Safety in use of power operated doors - Requirements

<sup>15</sup> Official Journal of the European Communities L 267/23 of 19/10/1996 and L258/36 of 12/10/2000

<sup>16</sup> EN 13501-1:2007 Fire classification of construction products and building elements - Part 1: Classification using data from reaction to fire tests

<sup>17</sup> Official Journal of the European Communities L 276/77 of 07/10/2006

#### 2.2.4.2 Temperature dependence

The change in the closing time at ambient temperatures from 0 °C to 40 °C shall be less than 25 % compared with the closing time at room temperature (20 °C).

#### 2.2.4.3 Corrosion reaction

No defined corrosion resistance (corresponds to Class 0) was verified for the closing device per EN 1670<sup>18</sup>.

### 3 Evaluation and attestation of conformity and CE marking

#### 3.1 System of attestation of conformity

Per Decision 1999/454/EC of the European Commission<sup>19</sup> and the amendment per Decision 2001/596/EC of the European Commission<sup>20</sup>, conformity attestation system 1 is applicable.

This system of conformity attestation is defined as follows:

System 1: Certification of the conformity of the product by an approved certification body on the basis of:

(a) Tasks for the manufacturer:

(1) Factory production control

(2) Further testing of samples taken at the factory by the manufacturer in accordance with a prescribed test plan

(b) Tasks for the approved body:

(3) Initial type testing of the product

(4) Initial inspection of the factory and of factory production control

(5) Continuous monitoring, assessment and approval of factory production control

Note: Approved bodies are also referred to as "notified bodies".

#### 3.2 Responsibilities

##### 3.2.1 Tasks for the manufacturer

###### 3.2.1.1 Factory production control

The manufacturer shall exercise permanent internal control of production. All the elements, requirements and provisions adopted by the manufacturer shall be documented in a systematic manner in the form of written policies and procedures, including records of results performed. This production control system shall ensure that the product is in conformity with this European technical approval.

The manufacturer is only to use components stated in the technical documentation of this European technical approval.

The factory production control shall be in accordance with the "Control plan of 23 May 2013 relating to the European technical approval ETA-13/0499 issued on 23 May 2013" which is part of the technical documentation of this European technical approval. The control plan is laid

<sup>18</sup> EN 1670:2007 Building hardware - Corrosion resistance - Requirements and test methods

<sup>19</sup> Official Journal of the European Communities L 178/52 of 14/7/1999

<sup>20</sup> Official Journal of the European Communities L 209/33 of 2/8/2001



down in the context of the factory production control system operated by the manufacturer and deposited with Deutsches Institut für Bautechnik<sup>21</sup>.

The results of factory production control shall be recorded and evaluated in accordance with the provisions of the control plan.

#### 3.2.1.2 Other tasks for the manufacturer

The manufacturer shall provide installation instructions which contain at least the following information:

- Information for the installation of the closure system (e.g., adjacent components, permitted fasteners, fastening distances, joint design)
- Notes on the sequence of steps for installation
- Information on the permitted accessory parts for the closure system
- Information on functional interplay of all parts
- Information on the use of hold-open systems
- Information on the interplay of the closure system, conveyor, hold-open system and emergency power supply

The manufacturer shall, on the basis of a contract, involve a body which is approved for the tasks referred to in section 3.1 in the field of closure systems for trackbound conveyors in order to undertake the actions laid down in section 3.2.2. For this purpose, the manufacturer shall submit the control plan in accordance with sections 3.2.1.1 and 3.2.2 to the approved body.

#### 3.2.2 Tasks for the approved bodies

The approved body shall perform the following tasks in accordance with the provisions of the control plan:

- Initial type-testing of the product
- Initial inspection of factory and of factory production control
- Continuous monitoring, assessment and approval of the factory production control

The approved body shall record the essential points of its actions referred to above and state the results obtained and conclusions drawn in a written report.

The approved certification body involved by the manufacturer shall issue an EC certificate of conformity of the product stating the conformity with the provisions of this European technical approval.

In cases where the provisions of the European technical approval and its control plan are no longer fulfilled, the certification body shall withdraw the certificate of conformity and inform Deutsches Institut für Bautechnik without delay.

#### 3.3 CE marking

The CE marking is to be attached to the closure itself (steel sheet plate) and printed on the accompanying commercial documents. The letters "CE" shall be followed by the identification number of the approved certification body and be accompanied by the following additional information:

- Trade name: Baureihe 104 EU
- Name and address of the manufacturer (legal entity responsible for the manufacture)
- Last two digits of the year in which the CE marking was affixed

<sup>21</sup> The control plan is a confidential part of the European technical approval and only handed over to the approved body involved in the procedure of attestation of conformity. See section 3.2.2.



- Number of the EC certificate of conformity for the product
- ETA number
- Use category (fire resistance and durability classification)
- Closing force

#### **4 Assumptions under which the fitness of the product for the intended use was favourably assessed**

##### **4.1 Manufacturing**

Steel parts no longer accessible after assembly shall be provided with lifetime corrosion protection. Steel parts accessible after assembly shall be provided with basic protection which is effective for at least three months after the delivery date.

Additional corrosion protection and basic protection (coatings) of the sheets are not required if galvanised fine sheets of at least zinc coating class Z 275 N A per EN 10346<sup>22</sup> are used.

The European technical approval is issued for the product on the basis of agreed data/information, deposited with Deutsches Institut für Bautechnik, which identifies the product that has been assessed and judged. Changes to the product or production process, which could result in this deposited data/information being incorrect, should be notified to Deutsches Institut für Bautechnik before the changes are introduced. Deutsches Institut für Bautechnik will decide whether or not such changes affect the approval and consequently the validity of the CE marking on the basis of the approval and if so whether further assessment or alterations to the approval shall be necessary.

##### **4.2 Installation**

The closure system shall be connected to the adjacent components in such a way that the forces which occur when the closure system closes automatically and the forces resulting from deformations during fires can be absorbed by the fasteners in the long term. These forces shall not endanger the stability of the adjacent structure.

The connections with the adjacent components shown in annex 5 fulfil this requirement without further verification.

Note: Other requirements for the installation and function of the "Type series 104 EU" and the requirement for acceptance testing can result in accordance with the national regulations.

#### **5 Indications to the manufacturer**

##### **5.1 Packaging, transport and storage**

When storing the intumescent material, the conditions in the assessment criteria (ambient air with temperatures between 0 °C and 40 °C and 50 to 80 % relative humidity) shall be observed.

## 5.2 Use, maintenance, repair

### Maintenance instructions

The manufacturer shall provide maintenance instructions for every "Type series 104 EU". The maintenance instructions shall clearly indicate which work is to be performed to ensure that the installed closure system continues to perform its task after long-term use.

### Inspection and maintenance

The "Type series 104 EU" shall be inspected for serviceability at least once a month. At least once a year, the system shall be maintained by qualified personnel authorised by the manufacturer. The results shall be noted in the test and maintenance log.

Note: Further maintenance requirements may result for the "Type series 104 EU" in conjunction with national regulations.

Prof. Gunter Hoppe  
Head of Department

*beglaubigt:*  
Biedermann

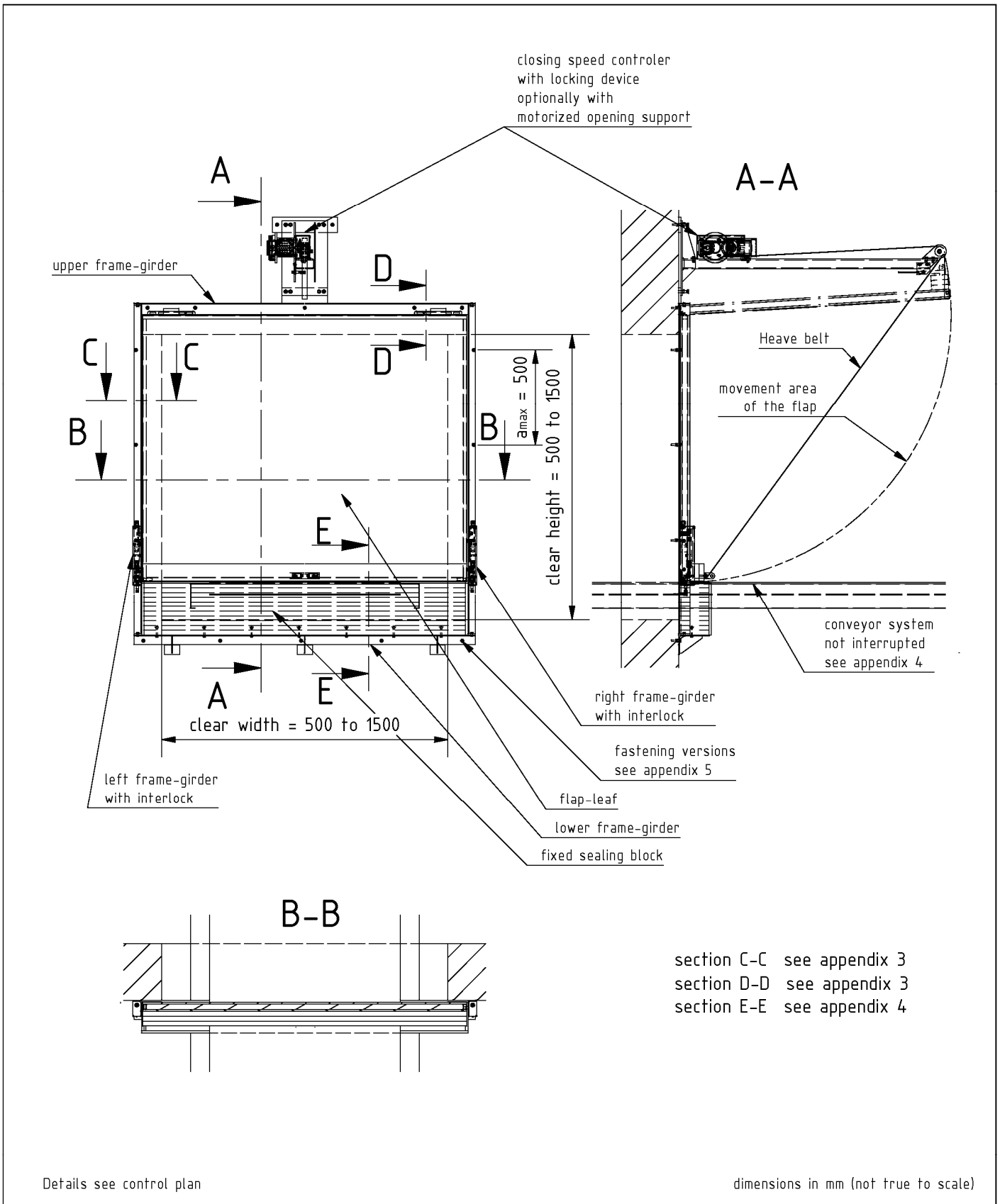

Electronic copy of the ETA by DIBt: ETA-13/0499

"Type series 104 EU"

Overview  
Installation in walls  
Flap for conveyor technique without side wall

**Annex 1**

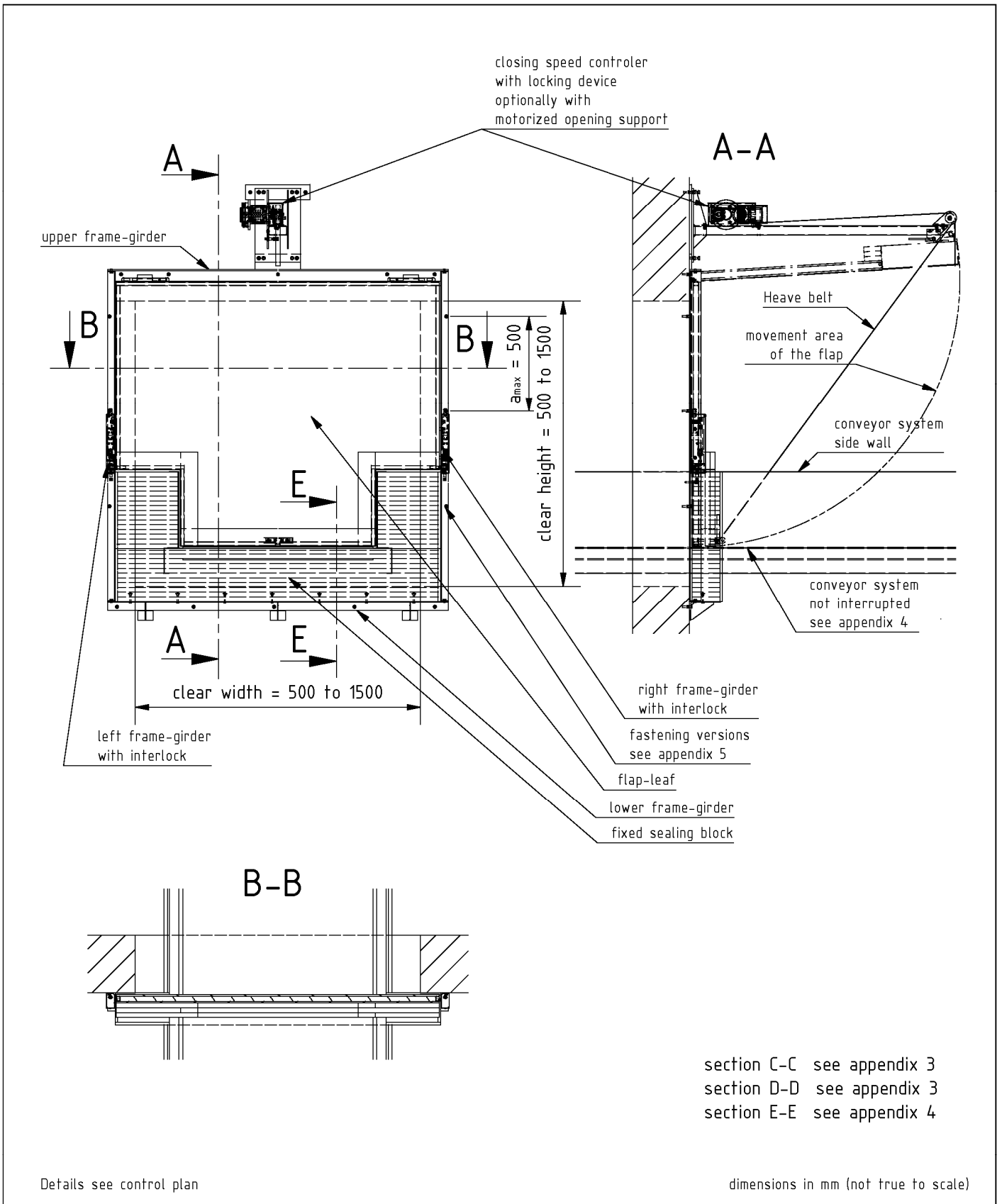

Electronic copy of the ETA by DIBt: ETA-13/0499

"Type series 104 EU"

Overview  
Installation in walls  
Flap for conveyor technique with side wall

**Annex 2**

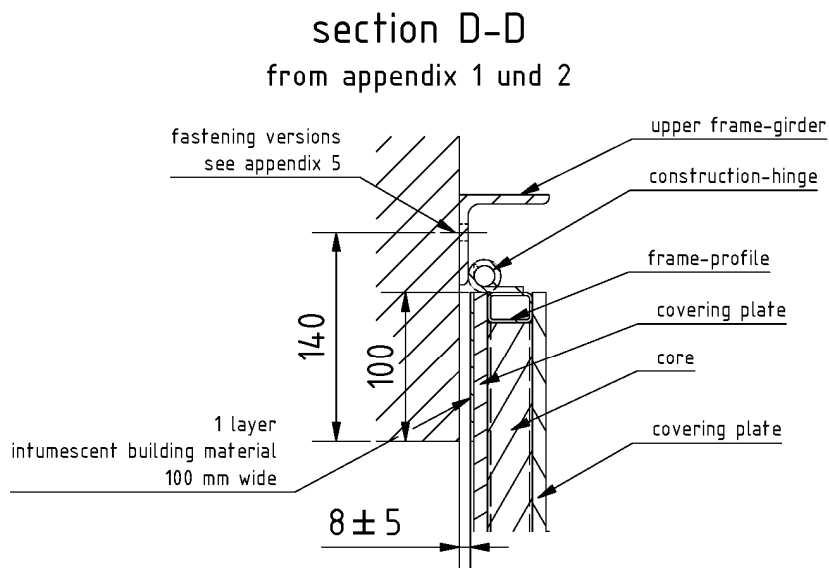
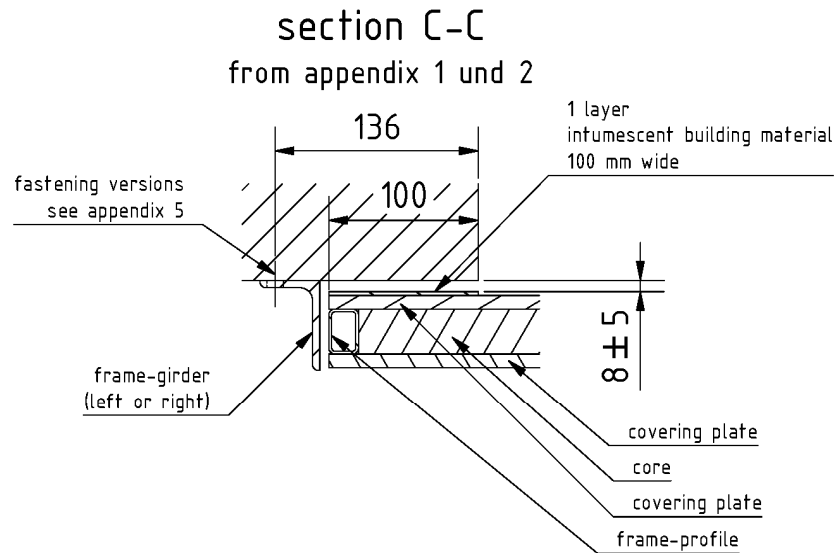

basic flap-leaf structure:

- core: calcium silicate board (30 mm)
- covering plate: calcium silicate board (9 mm)
- thickness of the flap-leaf = 48 mm

Details see control plan

dimensions in mm (not true to scale)

"Type series 104 EU"

Details concerning wall sealing  
- lateral (section C-C)  
- at the top (section D-D)

**Annex 3**

schematic diagram  
sealing of belt conveyor

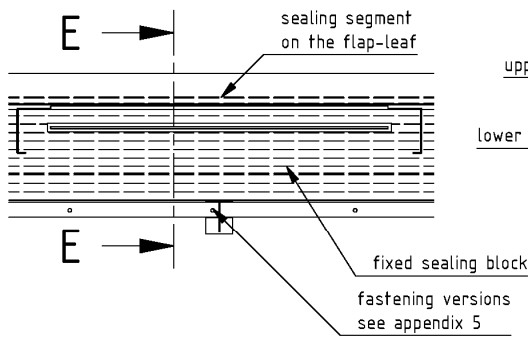

section E-E

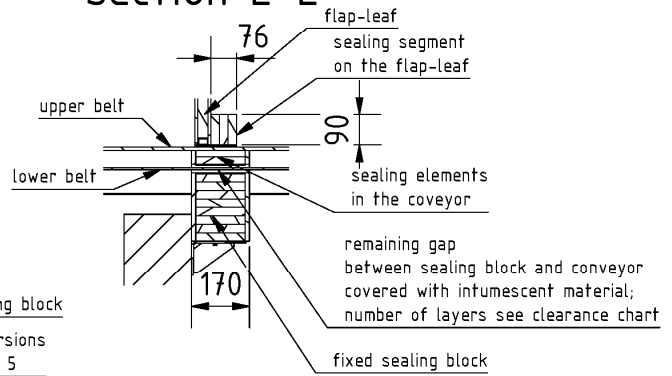

schematic diagram  
sealing of roller conveyor

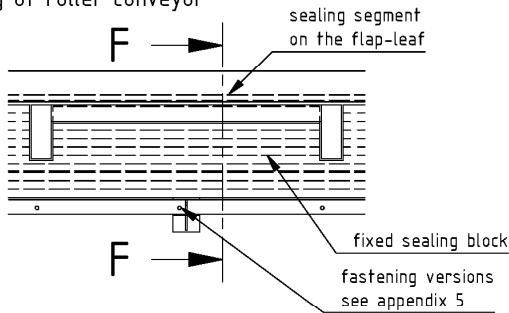

section F-F

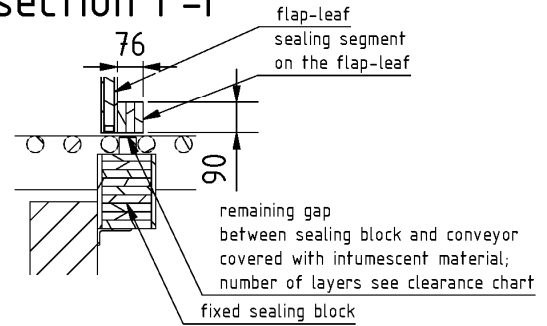

schematic diagram  
sealing of chain conveyor

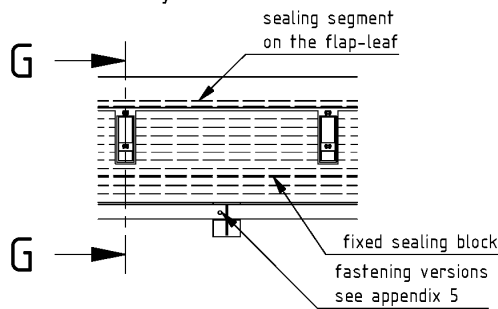

section G-G

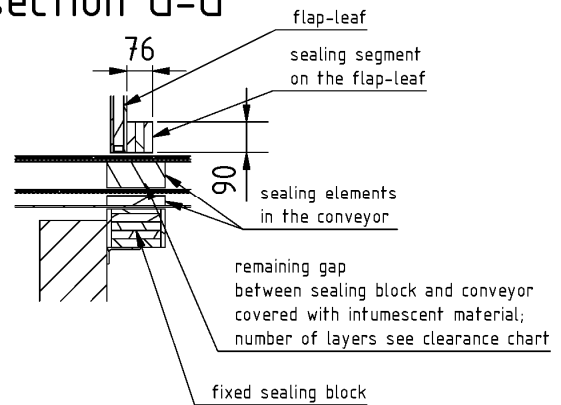

Details see control plan

clearance for remaining gaps between the continuous parts of the conveyor and the closure (application of intumescent material PROMASEAL-PL; thickness per layer: 2,5 mm)	
remaining gap (mm)	minimum number of layers
10 to 15	1 layer
16 to 30	2 layers
31 to 45	3 layers

Attention: the remaining gaps should be implemented as small as possible

dimensions in mm (not true to scale)

### manner of fastening 1

concrete wall, min. 175 mm thick  
masonry (solid walls with high density), min. 175 mm thick  
full-length threaded rod

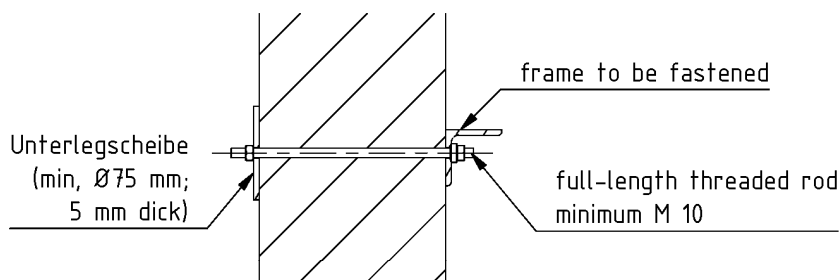

### manner of fastening 2

masonry (solid walls with low density), min. 175 mm thick  
full-length threaded rod

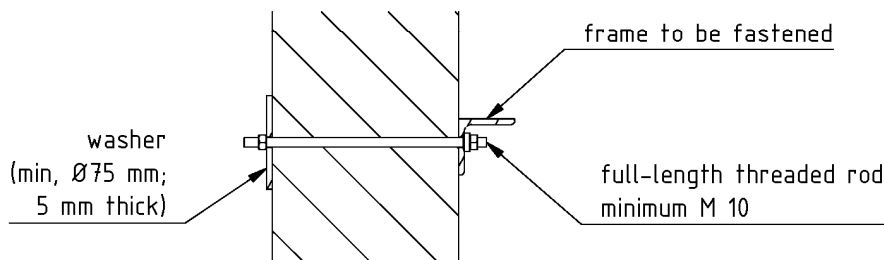

### manner of fastening 3

concrete wall, min. 175 mm thick  
dowels according to control plan of .....

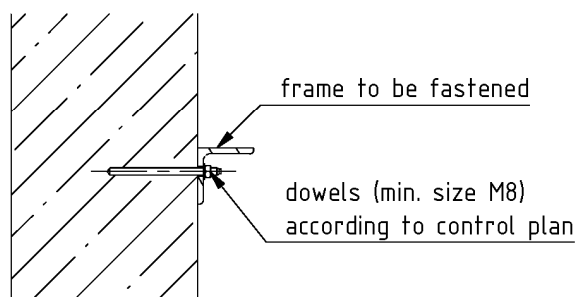

Details see control plan

dimensions in mm (not true to scale)

"Type series 104 EU"

Kind of fastening

**Annex 5**