

European Technical Approval ETA-13/0650

English translation prepared by DIBt - Original version in German language

Handelsbezeichnung
Trade name

Carl Stahl Seilnetzsysteme X-TEND
Carl Stahl Cable Net Systems X-TEND

Zulassungsinhaber
Holder of approval

Carl Stahl GmbH
Tobelstrasse 2
73079 Süssen
DEUTSCHLAND

Zulassungsgegenstand
und Verwendungszweck
*Generic type and use
of construction product*

Seilnetzsysteme
Cable Net Systems

Geltungsdauer:
Validity:

vom
from
bis
to

13 June 2013
13 June 2018

Herstellwerk
Manufacturing plant

Carl Stahl GmbH
Tobelstrasse 2
73079 Süssen
DEUTSCHLAND

Diese Zulassung umfasst
This Approval contains

24 Seiten einschließlich 15 Anhänge
24 pages including 15 annexes

I LEGAL BASES AND GENERAL CONDITIONS

- 1 This European technical approval is issued by Deutsches Institut für Bautechnik in accordance with:
 - Council Directive 89/106/EEC of 21 December 1988 on the approximation of laws, regulations and administrative provisions of Member States relating to construction products¹, modified by Council Directive 93/68/EEC² and Regulation (EC) N° 1882/2003 of the European Parliament and of the Council³;
 - *Gesetz über das In-Verkehr-Bringen von und den freien Warenverkehr mit Bauprodukten zur Umsetzung der Richtlinie 89/106/EWG des Rates vom 21. Dezember 1988 zur Angleichung der Rechts- und Verwaltungsvorschriften der Mitgliedstaaten über Bauprodukte und anderer Rechtsakte der Europäischen Gemeinschaften (Bauproduktengesetz - BauPG) vom 28. April 1998⁴, as amended by Article 2 of the law of 8 November 2011⁵;*
 - Common Procedural Rules for Requesting, Preparing and the Granting of European technical approvals set out in the Annex to Commission Decision 94/23/EC⁶.
- 2 Deutsches Institut für Bautechnik is authorized to check whether the provisions of this European technical approval are met. Checking may take place in the manufacturing plant. Nevertheless, the responsibility for the conformity of the products to the European technical approval and for their fitness for the intended use remains with the holder of the European technical approval.
- 3 This European technical approval is not to be transferred to manufacturers or agents of manufacturers other than those indicated on page 1, or manufacturing plants other than those indicated on page 1 of this European technical approval.
- 4 This European technical approval may be withdrawn by Deutsches Institut für Bautechnik, in particular pursuant to information by the Commission according to Article 5(1) of Council Directive 89/106/EEC.
- 5 Reproduction of this European technical approval including transmission by electronic means shall be in full. However, partial reproduction can be made with the written consent of Deutsches Institut für Bautechnik. In this case partial reproduction has to be designated as such. Texts and drawings of advertising brochures shall not contradict or misuse the European technical approval.
- 6 The European technical approval is issued by the approval body in its official language. This version corresponds fully to the version circulated within EOTA. Translations into other languages have to be designated as such.

¹ Official Journal of the European Communities L 40, 11 February 1989, p. 12
² Official Journal of the European Communities L 220, 30 August 1993, p. 1
³ Official Journal of the European Union L 284, 31 October 2003, p. 25
⁴ *Bundesgesetzblatt Teil I 1998*, p. 812
⁵ *Bundesgesetzblatt Teil I 2011*, p. 2178
⁶ Official Journal of the European Communities L 17, 20 January 1994, p. 34

II SPECIFIC CONDITIONS OF THE EUROPEAN TECHNICAL APPROVAL

1 Definition of the product and intended use

1.1 Definition of the construction product

The construction products are prefabricated cable net systems with trade name "Carl Stahl cable net systems X-TEND". The cable net systems consist of cables (net cables, lacing cables) made of stainless steel and the appropriate ferrules for connection and deviation of the cables as well as border cables or frames made of tubular sections as surround of the cable nets (see Annex 1). Deviating and anchoring of the border cables is done by appropriate components (shackles, eye bolts, eye nuts, end connectors). The opening angle of the cable net mesh is depending on the component geometry approx 60°. The mesh width is variable and is in-between 35 mm and 100 mm depending on the cable diameter.

1.2 Intended use

The intended use comprises all typical structural applications of prefabricated cable net systems made of stainless steel taking into account the national provisions of the Member State applicable for the location where the product is incorporated in the works whereby the installation occurs either as vertical cable net (e.g. railings) or horizontal cable net. The cable nets may be used as safety barrier (e.g. at helicopter bases, observation towers or bridges). Further fields of application are e.g. cable net systems for zoo enclosures or facades, also in 3D. Examples are given in Annexes 12 to 15.

Cable net systems with stainless steel ferrules of type CXS are intended for the use in structures with predominantly static loads only.

The provisions made in this European technical approval are based on an assumed working life of the prefabricated cable net systems of 25 years. The indications given on the working life cannot be interpreted as a guarantee given by the producer, but are to be regarded only as a means for choosing the right products in relation to the expected economically reasonable working life of the works.

2 Characteristics of the product and methods of verification

2.1 Characteristics of the product

2.1.1 Cables (net cables, lacing cables)

For the cables the indications given in EN 10264-4:2012 as well as in the series of the standards EN 12385 apply. In addition the indications in Annex 3 shall be taken into account.

For the strength classes the following applies:

Cable diameter [mm]	Wire tensile strength [N/mm ²]
1.5	≥ 1770
2.0	≥ 1770
3.0	≥ 1570

2.1.2 Border cables

For border cables the indications given in EN 10264-4:2012 as well as in the series of the standards EN 12385 apply. In addition the indications in Annex 6 shall be taken into account.

For the strength classes the following applies:

Type of rope	Wire tensile strength [N/mm ²]
Wire rope	≥ 1570
Spiral strand	according to European technical approval ETA-10/0358

2.1.3 Net ferrules, vertical ferrules, horizontal ferrules and diagonal ferrules

The indications given in Annexes 3 and 4 apply. Detailed indications of dimensions and material properties shall correspond to the indications laid down in the technical documentation⁷ to this European technical approval.

2.1.4 End connectors of the border cable

The end connectors of the border cables correspond to the end connectors laid down in the European technical approval ETA-10/0358. Incidentally the indications given in Annexes 2, 6, 7 and 9 to 11 apply.

2.1.5 Frame

The frames are made of tubular sections of stainless steel. The diameter of the tubular sections is 21.3 mm and the wall thickness is at least 2 mm (cf. Annex 8).

2.1.6 Shackles, eye bolts and eye nuts

The Shackles, eye bolts and eye nuts according to Annexes 5 und 6 are made of stainless steel. The materials and minimum breaking forces shall correspond to the indications laid down in the technical documentation⁷ to this European technical approval.

2.1.7 Characteristic and design values of tension resistance

The stated value for the partial safety factor γ_M is a recommended value. It should be used in cases where no values are given in national regulations of the Member State where the cable net systems are used or in the respective National Annex to Eurocode 3.

2.1.7.1 Characteristic and design values of the tension resistance of the cables and border cables

The characteristic and design values of the tension resistance F_{Rd} of the cables and border cables shall be determined as follows:

$$F_{Rk} = A_m \cdot f_{u,k} \cdot k_s \cdot k_e$$

$$F_{R,d} = F_{R,k} / (1,5 \cdot \gamma_M)$$

Where:

A_m : metallic cross section of the cables according to Annex 6

$f_{u,k}$: characteristic value of tension resistance of the wires ropes according to section 2.1

k_s, k_e : strand factor, loss factor according to Annex 6

γ_M : partial safety factor; as partial safety factor γ_M the value 1.1 is recommended.

The characteristic value of the tension resistance applies to the cable respectively border cable including the appropriate ferrules respectively end connector.

⁷ The technical documentation to this European technical approval is deposited with Deutsches Institut für Bautechnik and, as far as relevant for the tasks of the approved bodies involved in the attestation of conformity procedure is handed over to the approved bodies.

2.1.7.2 Characteristic and design values of the sliding force of the net ferrules

For the characteristic value of the sliding force $F_{SI,Rk}$ of the net ferrules the following applies:

Type of cable net	Cable diameter [mm]	Sliding force $F_{SI,Rk}$ [kN]
CX	1.5	0.15
	2.0	0.16
	3.0	0.24
CXS	1.5	0.72

The design values of the sliding force result from dividing the characteristic values by the partial safety factor γ_M . As partial safety factor γ_M the value 1.1 is recommended.

2.1.7.3 Characteristic and design values of load-bearing capacity of shackles, eye bolts and eye nuts

For the characteristic values of the tension resistance $F_{Sh,Rk}$ of the shackles, eye bolts and eye nuts the following applies:

eye bolt and eye nut		Shackle	
Size	Tension resistance $F_{Sh,Rk}$ [kN]	Size	Tension resistance $F_{Sh,Rk}$ [kN]
M 12	13.2	0.6	21.3
M 16	27.6	1.0	33.0
M 20	47.2	1.6	53.4
M 24	70.6		

The design values result from dividing the characteristic values by the partial safety factor γ_M . As partial safety factor γ_M the value 1.1 is recommended.

The design value of the shear force shall be determined according to EN 1993-1-4⁸.

2.1.8 Modulus of elasticity E_Q of the cables (net cables, lacing cables) and border cables

The following values shall apply:

Type of rope	E_Q [kN/mm ²]
Round strand rope	90
Spiral strand	130

2.1.9 Safety in case of fire

The prefabricated cable net systems are considered to satisfy the requirements of performance class A1 of the characteristic reaction to fire according to EN 13501-1:2007

2.1.10 Durability

The rules given in EN 1993-1-11:2006⁸, section 4 shall be taken into account.

Ferrules made of tin-plated copper must only be used for accessible constructions in surroundings without important chlorinity and sulphur dioxide. Industrial atmosphere has to be excluded.

⁸

In addition the corresponding National Annex and/or the national provisions of the Member State applicable for the location where the product is incorporated in the works shall be taken into account.

2.2 Methods of verification

2.2.1 General

The assessment of fitness for the intended use of the prefabricated cable net systems made of stainless steel with regard to the requirements for mechanical resistance and stability and safety in case of fire in the sense of the essential requirements N° 1 and 2 has been made in accordance with the sections 2.2.2 and 2.2.3.

2.2.2 Essential Requirement N° 1: Mechanical resistance and stability

The values for k_e were determined on the basis of the evaluation of tensile tests. The values for k_s are based on indications of the manufacturer.

The characteristic values of the net ferrules' sliding force were determined on the basis of the evaluation of sliding tests

The characteristic values of the tension resistance $F_{Sh,Rk}$ of the shackles, eye bolts and eye bolts were determined from the values stated in the corresponding product standards.

The values for the modulus of elasticity E_Q comply with the information in EN 1993-1-11:2006.

The verification of horizontal and vertical cable net systems as safety barrier was provided on the basis of tests according to EN 1263-1:2002 and EN 12600:2002.

2.2.3 Essential requirement N° 2: Safety in case of fire

The cable net systems are considered to satisfy the requirements of performance Class A1 according to EN 13501-1:2007 of the characteristic reaction to fire in accordance with the provisions of Commission Decision 96/603/EC (as amended) without the need for testing on the basis of its listing in that Decision.

3 Evaluation and attestation of conformity and CE marking

3.1 System of attestation of conformity

According to the communication of the European Commission⁹ system 2+ of the attestation of conformity applies.

This system of attestation of conformity is defined as follows:

System 2+: Declaration of conformity of the product by the manufacturer on the basis of:

- (a) Tasks for the manufacturer:
 - (1) initial type-testing of the product;
 - (2) factory production control;
 - (3) testing of samples taken at the factory in accordance with a prescribed test plan.
- (b) Tasks for the approved body:
 - (4) certification of factory production control on the basis of:
 - initial inspection of factory and of factory production control;
 - continuous surveillance, assessment and approval of factory production control.

Note: Approved bodies are also referred to as "notified bodies".

⁹ Letter of the European Commission of 16/01/2009 to EOTA

3.2 Responsibilities

3.2.1 Tasks for the manufacturer

3.2.1.1 Factory production control

The manufacturer shall exercise permanent internal control of production. All the elements, requirements and provisions adopted by the manufacturer shall be documented in a systematic manner in the form of written policies and procedures, including records of results performed. This production control system shall insure that the product is in conformity with this European technical approval.

The manufacturer may only use initial materials stated in the technical documentation of this European technical approval.

The factory production control shall be in accordance with the control plan which is part of the technical documentation of this European technical approval. The control plan is laid down in the context of the factory production control system operated by the manufacturer and deposited with Deutsches Institut für Bautechnik.¹⁰

The results of factory production control shall be recorded and evaluated in accordance with the provisions of the control plan.

3.2.1.2 Other tasks for the manufacturer

The manufacturer shall, on the basis of a contract, involve a body which is approved for the tasks referred to in section 3.1 in the field of cable net systems in order to undertake the actions laid down in section 3.2.2. For this purpose, the control plan referred to in sections 3.2.1.1 and 3.2.2 shall be handed over by the manufacturer to the approved body involved.

The manufacturer shall make a declaration of conformity, stating that the construction product is in conformity with the provisions of this European technical approval.

3.2.2 Tasks for the approved bodies

The approved body shall perform the

- initial inspection of factory and of factory production control,
- continuous surveillance, assessment and approval of factory production control

in accordance with the provisions laid down in the control plan.

The approved body shall retain the essential points of its actions referred to above and state the results obtained and conclusions drawn in a written report.

The approved certification body involved by the manufacturer shall issue an EC certificate of conformity of the factory production control stating the conformity with the provisions of this European technical approval.

In cases where the provisions of the European technical approval and its control plan are no longer fulfilled the certification body shall withdraw the certificate of conformity and inform Deutsches Institut für Bautechnik without delay.

¹⁰ The control plan is a confidential part of the European technical approval and only handed over to the approved body involved in the procedure of attestation of conformity. See section 3.2.2.

3.3 CE marking

The CE marking shall be affixed on each packaging of the cable net systems. The letters "CE" shall be followed by the identification number of the approved certification body, where relevant, and be accompanied by the following additional information:

- the name and address of the producer (legal entity responsible for the manufacture),
- the last two digits of the year in which the CE marking was affixed,
- the number of the EC certificate for the factory production control,
- the number of the European technical approval,
- the type or name of the product.

Where the Regulation (EU) No. 355/2011 includes further or contrary provisions for CE marking, the provisions of Regulation (EU) No. 305/2011 apply.

4 Assumptions under which the fitness of the product for the intended use was favourably assessed

4.1 Manufacturing

The European technical approval is issued for the product on the basis of agreed data/information, deposited with Deutsches Institut für Bautechnik, which identifies the product that has been assessed and judged. Changes to the product or production process, which could result in this deposited data/information being incorrect, should be notified to Deutsches Institut für Bautechnik before the changes are introduced. Deutsches Institut für Bautechnik will decide whether or not such changes affect the approval and consequently the validity of the CE marking on the basis of the approval and if so whether further assessment or alterations to the approval shall be necessary.

4.2 Installation

The installation is solely carried out according to the manufacturer's instructions. The manufacturer hands over the assembly instructions to the assembler. The assembly instruction shall in particular contain indications to the pre-stressing of the cable net systems. The cable net systems are placed in a way to allow for their accessibility for maintenance and repair.

The cable nets may only be installed by firms experienced in this field.

Prior to installation, all components of the cable net systems shall be checked for their perfect quality. Damaged components shall not be used.

By using border cables with end connectors consisting of threaded end connector, turnbuckle and fork end connector with thread (see Annexes 2, 6, 7 and 9 to 11) the threaded end connectors as well as the fork end connectors with thread are screwed into the turnbuckles with a minimum thread engagement corresponding to the dimension "c" according to Annex 6 of the European technical approval ETA-10/0358.

The cable net systems with ferrules of tinned copper are only used for accessible constructions in an environment without considerable content of chlorides and sulphur dioxides. Industrial climate shall be excluded.

The responsible assembler attests by notation that all connections with threads were checked concerning the keeping of the minimum thread engagements.

The conformity of the adjacent structures and the installation of the cable net systems with the provisions of the European technical approval is attested by the executing company.

4.3 Design

The design is carried out according to EN 1993-1-11:2006+AC:2009⁸.

The loading is predominantly static.

The design values of resistance and modulus of elasticity given in sections 2.1.7 and 2.1.8 are used for verification of the ultimate limit state.

The verification of the cable net systems at ultimate limit state is fulfilled if the loading of the cables, border cables, net ferrules, shackles, eye bolts and eye nuts does not exceed the design values of resistance given in section 2.1.7.

The difference force between two net cables placed side by side and connected by net ferrules is less than the design value of the sliding force of the net ferrules according to section 2.1.7.

For the verification of the ultimate limit state of shackles, eye bolts and eye nuts it is considered that a linear verification of interaction in case of combined loadings of tension and shear force shall be proved. The verification at ultimate limit state takes into account if eye bolts and eye nuts are additionally imposed by bending loads.

The safety barrier is considered to be present if the conditions specified in Annexes 7 to 11 are compiled with.

For other variants the detection of the safety barrier must be performed by a static calculation.

The dimensions, tolerances, material properties and thread engagements stated in this European technical approval are observed.

The design is carried out by a designer of the structure experienced in the field of steel structures.

5 Indications to the manufacturer

The manufacturer shall ensure that the information on the specific conditions according to sections 1, 2, 4.2 and 4.3 (including Annexes referred to) is given to those who are concerned. This information may be given by reproduction of the European technical approval.

In addition all essential installation data shall be shown clearly on the package or on an enclosed instruction sheet, preferably using illustration(s).

The cable net systems shall be packaged and delivered as a complete unit only.

During use damaged cable nets have to be repaired and replaced if necessary by qualified companies.

Cable nets used for falling or bounding persons have to be checked for damages by the owner/user at least once a year. The cable nets have to be checked and repaired or replaced if necessary by qualified companies if loaded by falling or bounding persons.

Andreas Kummerow
p. p. Head of Department

beglaubigt:
Hahn

X-TEND CX, cable Ø 1.5 to 3.0 mm

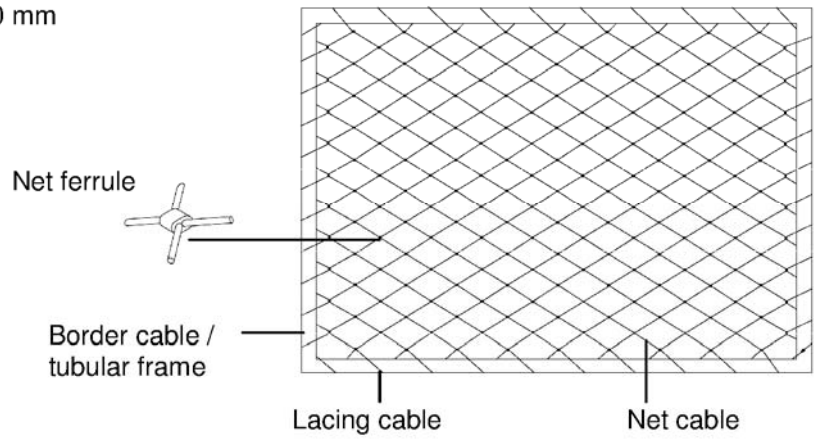

X-TEND CXS, cable Ø 1.5 mm

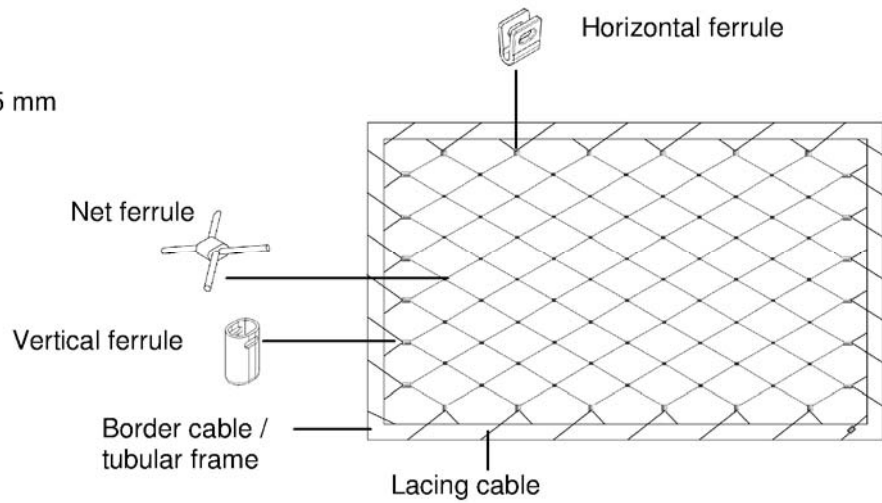

X-TEND CXS
with diagonal mesh direction,
cable Ø 1.5 mm

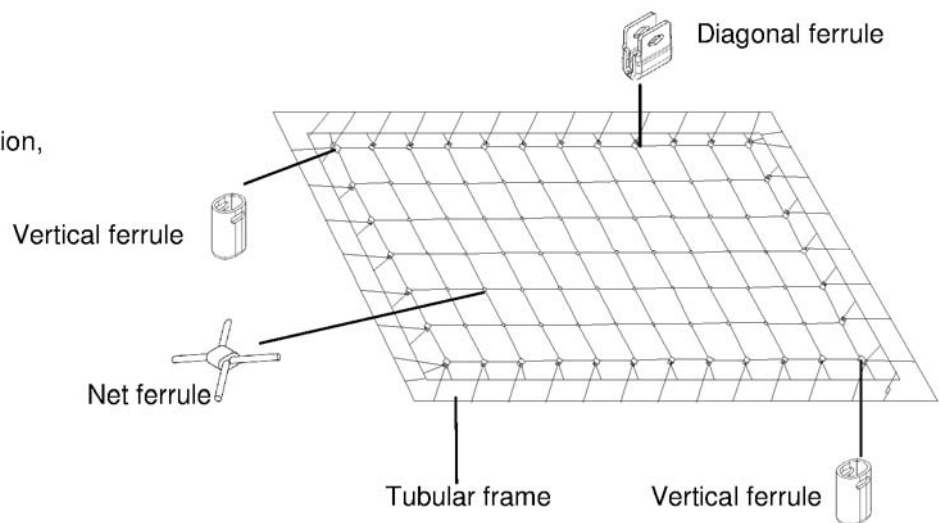

Carl Stahl Cable Net Systems X-TEND

Examples for cable nets

Annex 1

Border cable guided by eye bolts
respectively eye nuts,
for positioning / redirectioning

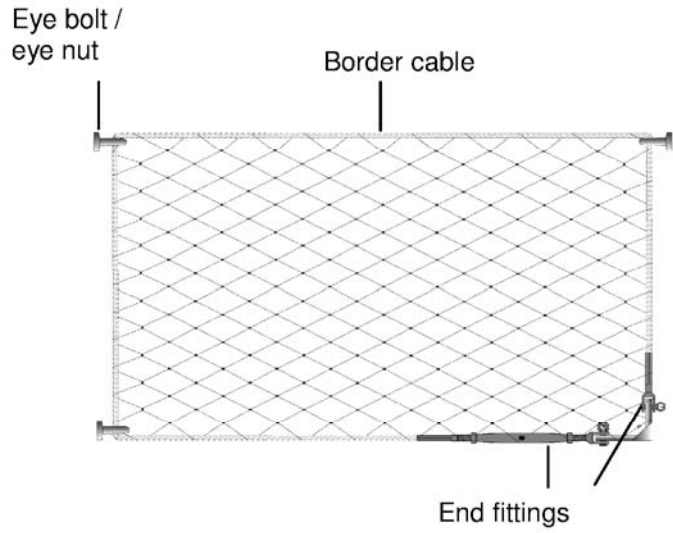

Border cable guided by shackles,
for positioning / redirectioning

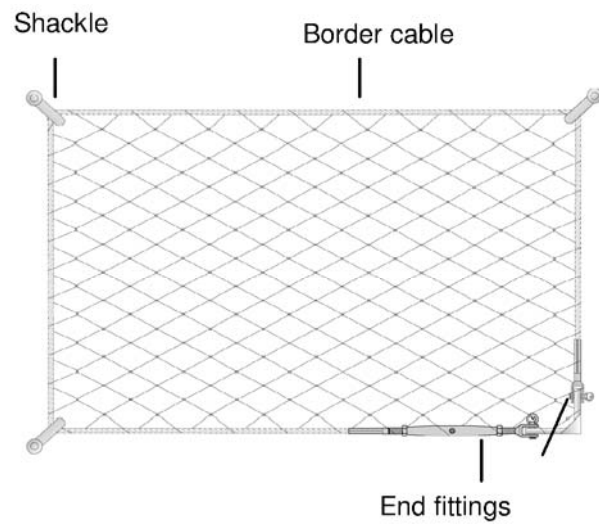

For border cables, see annex 6

Table 1: Types of cable nets, cables and net ferrules

Type	Wire Rope Construction	Cable Ø [mm]	Material (cable)	Mesh width MW [mm]	Material (ferrules)	a [mm]	L [mm]	t [mm]
CX	Wire rope 7 x 7	1.5	AISI316	35 to 100	Tin-plated copper	7.30	7.90	2.80
		2.0	AISI316	50 to 100	Tin-plated copper	10.10	8.90	3.50
	Wire rope 7 x 19	3.0	AISI316	60 to 100	Tin-plated copper	10.50	11.10	4.55
CXS	Wire rope 7 x 7	1.5	AISI316	35 to 100	Stainless steel (AISI316)	7.40	5.50	3.15

Net Ferrule

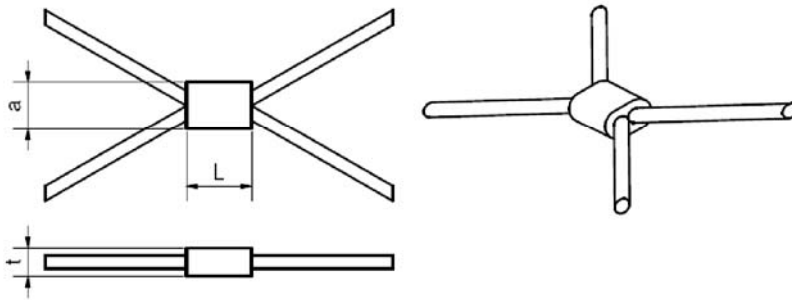

Vertical mesh diamond direction

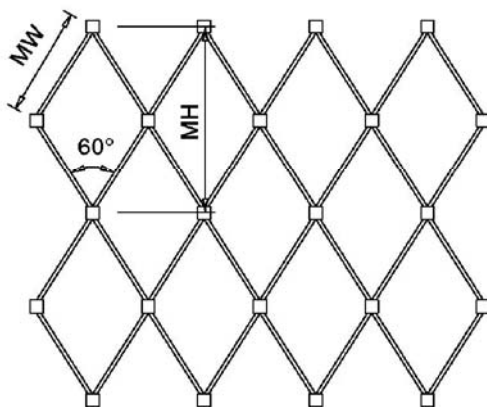

Horizontal mesh diamond direction

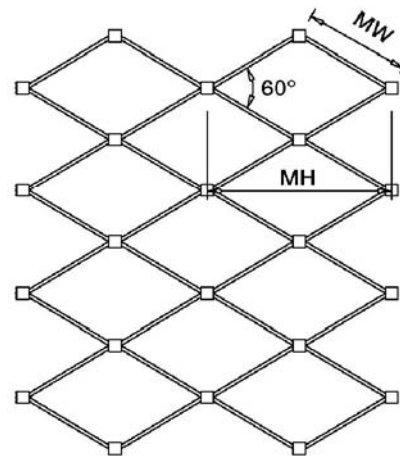

Carl Stahl Cable Net Systems X-TEND

Types of cable nets, cables and net ferrules

Annex 3

Horizontal ferrule

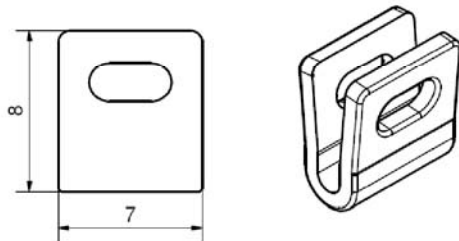

Vertical ferrule

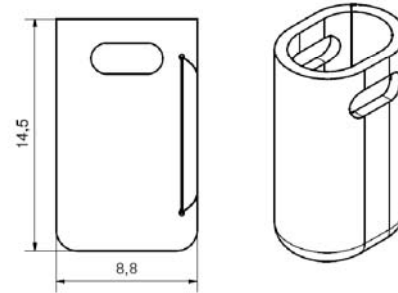

Diagonal ferrule

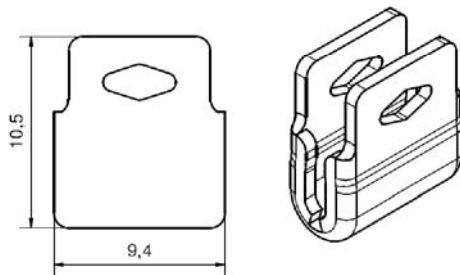

Sleeve for vertical ferrule

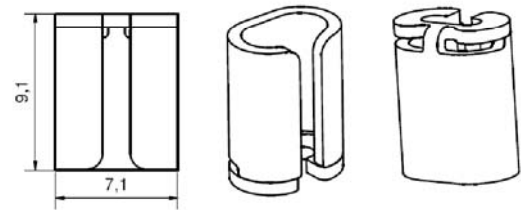
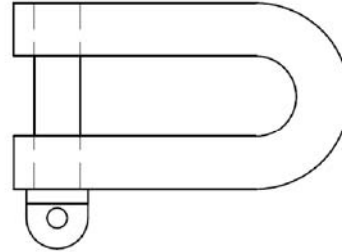

Table 2: Ferrules for border connection of X-TEND CXS mesh with lacing cable

Type	Border ferrule type	Cable Ø [mm]	Material (Cable)	Material (Ferrule)
CXs	Horizontal ferrule	1.5	AISI316	AISI316
	Vertical ferrule			
	Diagonal ferrule			

High tensile shackle
according to technical documentation



Eye nut
according to technical documentation

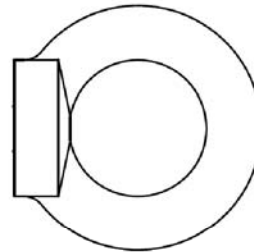

Eye bolt
according to technical documentation

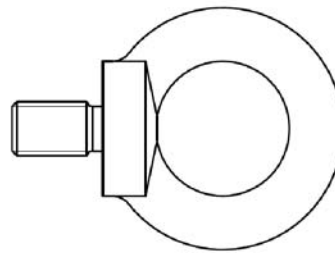

Electronic copy of the ETA by DIBt: ETA-13/0650

Carl Stahl Cable Net Systems X-TEND

Shackle, eye nut and eye bolt for positioning and redirection of border cables

Annex 5

Table 3: k_e - Values for fixation and redirectioning of net cables, Stranding faktor k_s and metallic cross section A_m of the net cables

Type	Ferrule	Cable Ø [mm]	k_e	k_s	A_m [mm ²]
CX	Net ferrule	1.5	0.75	0.79	0.97
		2.0	0.80	0.83	1.73
		3.0	0.80	0.81	3.75
CXS	Net ferrule	1.5	0.70	0.79	0.97
	Horizontal ferrule		0.40		
	Vertical ferrule		0.25		
	Diagonal ferrule		0.55		

Table 4: k_e - Values for connection and redirectioning of the border cables

Design	Border cable Ø [mm]	Construction (border cable)	Border cable with change of direction (redirectioning)							Border cable without redirectioning
			Shackle (nominal size)			Eye nut Eye bolt				
			0,6	1	1,6	M12	M16	M20	M24	
Wire rope	8	7 x 19	0.65	0.65	0.65	0.57	0.65	0.65	0.65	0.65
	10		0.65	0.65		0.57	0.65	0.65	0.65	
	12		0.57	0.57			0.57	0.57	0.57	
	16			0.57			0.57	0.57	0.57	
Spiral strand	8	1 x 19	Change of cable direction is not allowed							See European technical approval ETA-10/0358
	10									
	12									
	16	1 x 37								

End fittings of border cables are defined in the European technical approval ETA-10/0358

Table 5: Stranding faktor k_s und metallic cross section A_m of the border cables

Construction of border cable	Border cable Ø [mm]	k_s	A_m [mm ²]
Wire rope 7 x 19	8	0.77	26.53
	10	0.77	41.45
	12	0.77	59.69
	16	0.77	106.12
Spiral strand 1 x 19	8	See European technical approval ETA-10/0358	
	10		
	12		
Spiral strand 1 x 37	16		

Carl Stahl Cable Net Systems X-TEND

k_e - Values for fixation/connection and redirectioning of net cables and border cables, Stranding faktor k_s and metallic cross section A_m of the net cables and border cables

Annex 6

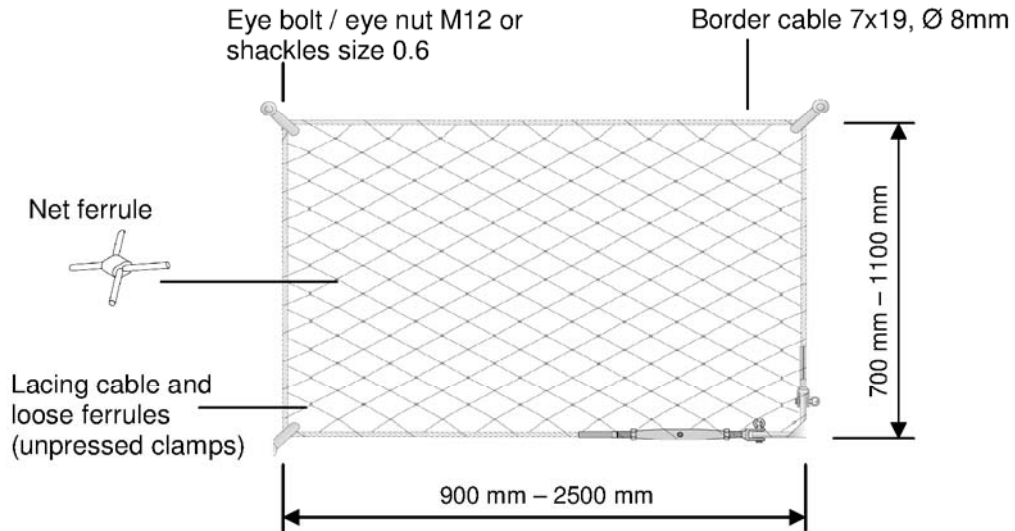

Conditions for the approved security against fall:

1. Net type CX
 - (a) Cable dia. 1.5mm: mesh width from 35mm to 60mm
 - (b) Cable dia. 2.0mm: mesh width from 50mm to 60mm
2. Rectangular cable nets with the aforementioned panel dimensions, with cables running through in longitudinal direction (width direction), and are linked with net ferrules in transversal direction (height direction).
3. Mounting on stainless steel border cable 7x19, Ø 8mm, tensile breaking strength 1570N/mm², guided around corners by eye bolts / eye nuts M12, or shackles of size 0.6.
4. Lacing cable according to net cables; fixing between the net cable and the lacing cable through loose ferrules (unpressed clamps), made of tin-plated copper ferrules, along the edges of the mesh panel.
5. Handrail according to national provisions of the Member state where the cable net is to be erected.

Carl Stahl Cable Net Systems X-TEND

Vertical cable nets (railing) with approved security against fall
Net type CX with border cable

Annex 7

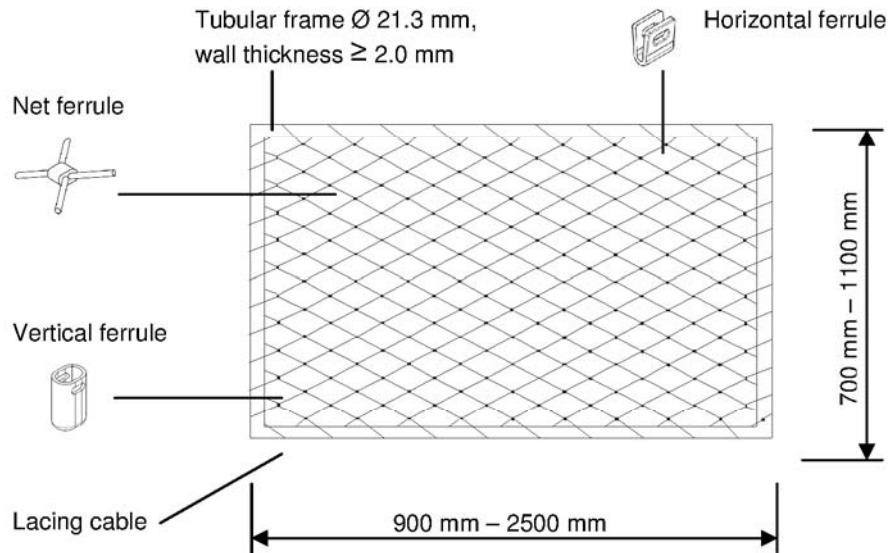

Conditions for the approved security against fall:

1. Net type CXS, cable diameter 1.5mm, mesh width from 35mm to 60mm
2. Rectangular cable nets with the aforementioned panel dimensions, with cables running through in longitudinal direction (width direction), and are linked with net ferrules in transversal direction (height direction).
3. Border fixation onto tubular frame made of stainless steel, tube dia. 21.3mm, wall thickness ≥ 2.0 mm.
4. Lacing cable according to net cables; fixing of the net to the tubular frame is done by lacing the lacing cable through border ferrules (vertical, horizontal or diagonal ferrules), made of stainless steel, along the edges of the net panel.
5. Handrail according to national provisions of the Member state where the cable net is to be erected.

Carl Stahl Cable Net Systems X-TEND

Vertical cable nets (railing) with approved security against fall
Net type CXS with tubular frame

Annex 8

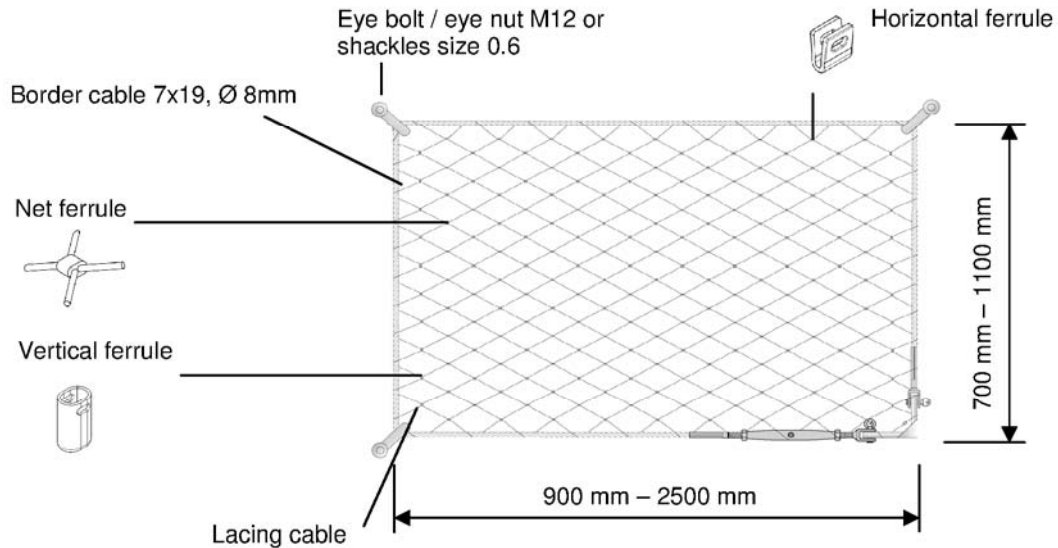

Conditions for the approved security against fall:

1. Net type CXS, cable dia. 1.5mm, mesh width from 35mm to 60mm.
2. Rectangular mesh panel with the aforementioned panel dimensions, with cables running through in longitudinal direction (width direction), and are linked with net ferrules in transversal direction (height direction).
3. Stainless steel border cable 7x19, Ø 8mm, tensile breaking strength 1570N/mm², guided around corners by eye bolts / eye nuts M12, or shackles of size 0.6.
4. Lacing cable according to net cable; the fixing of the net to the border cable is done by lacing the lacing cable through border ferrules (horizontal, vertical, or diagonal), made of corrosion resistant material, along the edges of the net panel.
5. Handrail according to national provisions of the Member state where the cable net is to be erected.

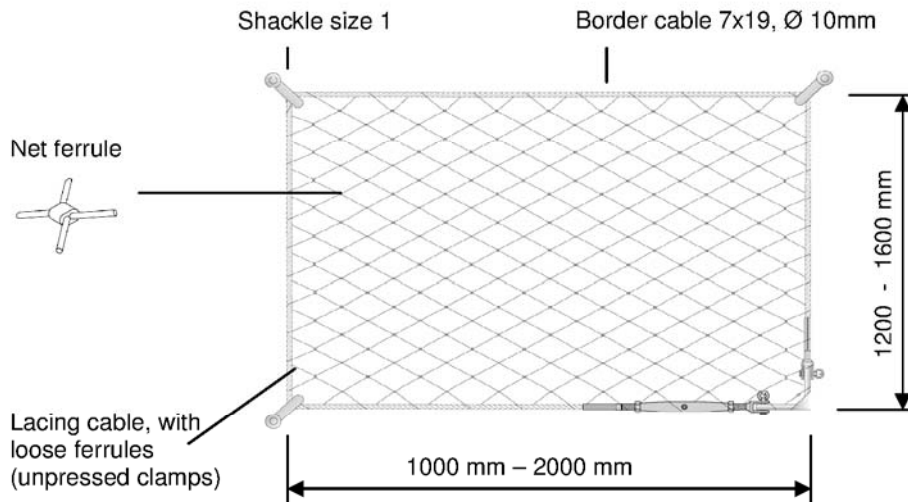

Conditions for the approved security against fall:

1. Net type CX, cable dia. 3.0mm, mesh width from 60mm to 100mm.
2. Rectangular mesh panel with the aforementioned panel dimensions, with cables running through in longitudinal direction and are linked with net ferrules in transversal direction, or run through in transversal direction and are linked with net ferrules in longitudinal direction.
3. Stainless steel border cable 7x19, Ø 10mm, tensile breaking strength 1570N/mm², guided around corners by shackles of size 1.
4. Lacing cable according to net cable; fixing between the cable net and the lacing cable through loose ferrules (unpressed clamps) made of tin-plated copper, along the edges of the mesh panel.
5. Maximum drop height in accordance to the panel dimensions:
 - (a) 2000mm x 1600mm: maximum drop height 2.0m
 - (b) 1000mm x 1200mm: maximum drop height 1.0m,
 - (c) Other dimensions according to paragraph 2.: maximum drop height via interpolation between a) and b).

Carl Stahl Cable Net Systems X-TEND

Horizontal cable nets with approved safety against fall
Net type CX with border cable

Annex 10

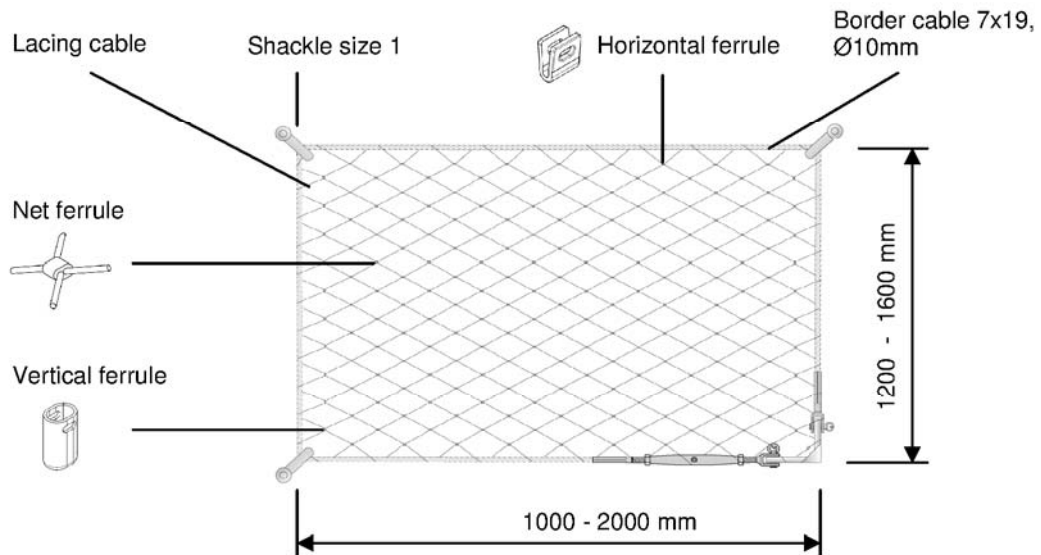

Conditions for the approved security against fall:

1. Net type CXS, cable dia. 1.5mm, mesh width 35mm
2. Rectangular mesh panel with the aforementioned panel dimensions, with cables running through in longitudinal direction, and are linked with net ferrules in transversal direction, or running through in transversal direction, and are linked with net ferrules in longitudinal direction.
3. Stainless steel border cable 7x19, Ø 10mm, tensile breaking strength 1570N/mm², guided around corners by shackles of size 1.
4. Lacing cable according to net cable; the fixing of the mesh to the border cable is done by lacing the lacing cable through border ferrules (horizontal, vertical, or diagonal), made of corrosion resistant material, along the edges of the mesh panel.
5. Maximum drop height 1.0 m.

Carl Stahl Cable Net Systems X-TEND

Horizontal cable nets with approved security against fall
Net type CXS with border cable

Annex 11

Vertical cable net, cable Ø 1.5 mm
Type CXS



Vertical cable net, cable Ø 1.5 mm
Type CXS

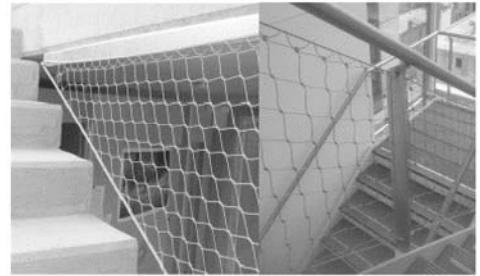

Vertical cable net, cable Ø 2.0 mm
Type CX



Vertical cable net, cable Ø 2.0 mm
Type CX



Vertical cable net, cable Ø 1.5 mm
Type CX

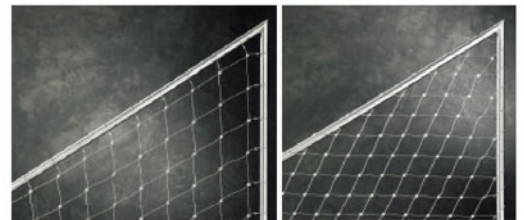

Carl Stahl Cable Net Systems X-TEND

Examples for vertical cable nets

Annex 12

Horizontal cable net, cable Ø 3.0 mm
Type CX

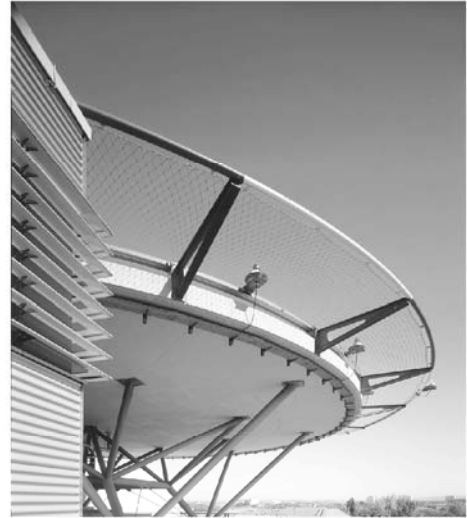

Horizontal cable net, cable Ø 3.0 mm
Type CX



Horizontal cable net, cable Ø 3.0 mm
Type CX



Carl Stahl Cable Net Systems X-TEND

Examples for horizontal cable nets

Annex 13

Façade cable nets

cable Ø 1.5 – 3.0 mm
Type CX

cable Ø 1.5mm
Type CXS

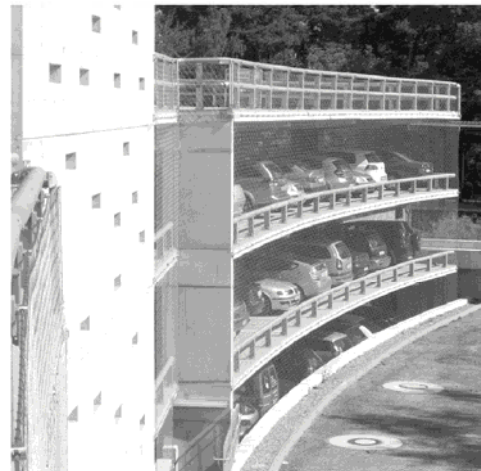

Carl Stahl Cable Net Systems X-TEND

Examples for façade cable nets

Annex 14

Cable nets for zoo enclosures and
aviaries

Cable Ø 1.5 mm - 3.0 mm
Typ CX

Cable Ø 1.5 mm
Typ CXS



Carl Stahl Cable Net Systems X-TEND

Examples for zoo enclosures and aviaries

Annex 15