

European Technical Approval ETA-13/0914

English translation prepared by DIBt - Original version in German language

Handelsbezeichnung
Trade name

"BD01...-S90" bzw. "BD01...-S120"
"BD01...-S90" and "BD01...-S120"

Zulassungsinhaber
Holder of approval

Siemens AG
Frohnhofstraße 103-107
50827 Köln
DEUTSCHLAND

Zulassungsgegenstand
und Verwendungszweck
*Generic type and use
of construction product*

Bausatz für Abschottung des Stromschiensystems "BD01..."
kit for penetration seal for bus bars "BD01..."

Geltungsdauer:
Validity: vom
from
bis
to

28 June 2013
28 June 2018

Herstellwerk
Manufacturing plant

Siemens, s.r.o. ,
odštepňý závod Busbars Trunking Systems
CZ 789 85 Mohelnice, Česká Republika

Diese Zulassung umfasst
This Approval contains

20 Seiten einschließlich 12 Anhänge
20 pages including 12 annexes

I LEGAL BASES AND GENERAL CONDITIONS

- 1 This European technical approval is issued by Deutsches Institut für Bautechnik in accordance with:
 - Council Directive 89/106/EEC of 21 December 1988 on the approximation of laws, regulations and administrative provisions of Member States relating to construction products¹, modified by Council Directive 93/68/EEC² and Regulation (EC) N° 1882/2003 of the European Parliament and of the Council³;
 - Gesetz über das In-Verkehr-Bringen von und den freien Warenverkehr mit Bauprodukten zur Umsetzung der Richtlinie 89/106/EWG des Rates vom 21. Dezember 1988 zur Angleichung der Rechts- und Verwaltungsvorschriften der Mitgliedstaaten über Bauprodukte und anderer Rechtsakte der Europäischen Gemeinschaften (Bauproduktengesetz – BauPG) vom 28. April 1998⁴, as amended by Article 2 of the law of 8 November 2011⁵;
 - Common Procedural Rules for Requesting, Preparing and the Granting of European technical approvals set out in the Annex to Commission Decision 94/23/EC⁶;
 - Guideline for European technical approval of "Fire Stopping and Fire Sealing Products - Part 2: Penetration Seals", ETAG 026-02.
- 2 Deutsches Institut für Bautechnik is authorized to check whether the provisions of this European technical approval are met. Checking may take place in the manufacturing plant. Nevertheless, the responsibility for the conformity of the products to the European technical approval and for their fitness for the intended use remains with the holder of the European technical approval.
- 3 This European technical approval is not to be transferred to manufacturers or agents of manufacturers other than those indicated on page 1, or manufacturing plants other than those indicated on page 1 of this European technical approval.
- 4 This European technical approval may be withdrawn by Deutsches Institut für Bautechnik, in particular pursuant to information by the Commission according to Article 5(1) of Council Directive 89/106/EEC.
- 5 Reproduction of this European technical approval including transmission by electronic means shall be in full. However, partial reproduction can be made with the written consent of Deutsches Institut für Bautechnik. In this case partial reproduction has to be designated as such. Texts and drawings of advertising brochures shall not contradict or misuse the European technical approval.
- 6 The European technical approval is issued by the approval body in its official language. This version corresponds fully to the version circulated within EOTA. Translations into other languages have to be designated as such.

¹ Official Journal of the European Communities L 40, 11 February 1989, p. 12
² Official Journal of the European Communities L 220, 30 August 1993, p. 1
³ Official Journal of the European Union L 284, 31 October 2003, p. 25
⁴ *Bundesgesetzblatt Teil I* 1998, p. 812
⁵ *Bundesgesetzblatt Teil I* 2011, p. 2178
⁶ Official Journal of the European Communities L 17, 20 January 1994, p. 34

II SPECIFIC CONDITIONS OF THE EUROPEAN TECHNICAL APPROVAL

1 Definition of the product and intended use

1.1 Definition of the construction product

This European Technical Approval refers to a penetration seal for the bus bar trunking system with the designation "BD01...-S90" for installation in fire resistant walls or floors or "BD01...-S120" for installation in fire resistant floors respectively.

The kit consists of a bus bar trunking unit "BD01-...", fire protective boards for the lining of the bus bar trunking unit and a sealant.

The bus bar trunking unit "BD01-...", the factory produced fire protective boards and the sealant have to be in accordance with Appendix 1.

Ancillary products referred to in this European Technical Approval within the framework of evaluating resistance to fire (see Annexes 1 and 2) are not covered by this ETA and cannot be CE-marked on the basis of it.

1.2 Intended use

The kit is intended to form part of a penetration seal, which is used to maintain the fire resistance of a wall or floor when and where bus bar trunking units of the type "BD01-..." pass through the wall or floor.

Annex 2 gives details of penetration seals for which fire resistance tests were carried out. This ETA covers assemblies installed in accordance with the provisions given in Annex 2.

Although a penetration seal is intended for indoor applications only, the construction process may result in it being subjected to more exposed conditions for a period before the building envelope is closed. For this case provisions shall be made to protect temporarily exposed penetration seals according to the instructions of the manufacturer.

The provisions made in this European Technical Approval are based on an assumed working life of the penetration seal for the bus bar trunking unit "BD01-..." of 25 years provided the conditions laid down in sections 4 and 5 relating to manufacturing, installation, use and repair are met. The indications given on the working life cannot be interpreted as a guarantee given by the producer, but are to be regarded only as a means for choosing the right products in relation to the expected economically reasonable working life of the works.

2. Characteristics of product(s) and methods of verification

2.1 Reaction to fire

The components of the kit fulfil the requirements for reaction to fire classes according to EN 13501-1 as specified in Annex 1.

2.2 Resistance to fire

The resistance to fire performance according to EN 13501-2 of penetration seals incorporating the kit "BD01...-S90" or "BD01...-S120" are given in the Annexes 4 to 6.

In the annexes the maximum verified fire resistance class – under the respective installation conditions – is specified. If installed in walls or floors of the same thickness and density and with the same structure as specified there, but with a lower fire resistance class, the fire resistance class of the penetration seal is reduced to the fire resistance class of the wall or floor.

Information on ancillary products which were tested within the framework of this European Technical Approval for evaluating resistance to fire of the penetration seal is given in Annex 1. Any changes in the material, the composition, the dimensions or the properties of the ancillary products shall be notified to Deutsches Institut für Bautechnik without delay, which will decide whether a new assessment will be necessary.

2.3 Emission of dangerous substances or radiation

The components of the kit "BD01...-S90" or "BD01...-S120" respectively do not contain any substances registered as dangerous substances in the list of the European Commission

For the bus bar trunking unit "BD01-..." and the sealant manufacturer's declarations, that these products do not contain dangerous substances specified in Directive 67/548/EEC or Regulation (EC) N° 1272/2008 or the Indicative List on Dangerous Substances were made available to the Deutsches Institut für Bautechnik.

For the fire protective boards "PROMATECT-200" and "PROMATECT-H" see ETA-07/0297 or ETA-06/0206 respectively.

Note: In addition to the specific clauses relating to dangerous substances contained in this European Technical Approval, there may be other requirements applicable to the products falling within its scope (e.g. transposed European legislation and national laws, regulations and administrative provisions). In order to meet the provisions of the Construction Products Directive, these requirements need also to be complied with, when and where they apply.

2.4 Durability and serviceability

The components of the kit "BD01...-S90" or "BD01...-S120" for penetration seals of bus bar trunking units fulfil the requirements of use category Z2 in accordance with ETAG 026-2, Section 1.2. That means that the materials can be exposed to the conditions in interiors with out high humidity without expecting significant changes in the fire protective characteristic values.

3 Evaluation and attestation of conformity and CE marking

3.1 System of attestation of conformity

According to the decision 1999/454/EG, amended by Decision 2001/596/EC of the European Commission⁷ the system 1 of attestation of conformity applies.

This system of attestation of conformity is defined as follows:

System 1: Certification of the conformity of the product by a notified product certification body on the basis of:

⁷ Official Journal of the European Communities L .../... (number) of ... (day/month/year)

- (a) Tasks for the manufacturer:
 - (1) factory production control;
 - (2) further testing of samples taken at the factory by the manufacturer in accordance with a prescribed test plan;
- (b) Tasks for the notified body:
 - (3) initial type-testing of the product;
 - (4) initial inspection of factory and of factory production control;
 - (5) continuous surveillance, assessment and approval of factory production control.

3.2 Responsibilities

3.2.1 Tasks of the manufacturer

3.2.1.1 Factory production control

The manufacturer shall exercise permanent internal control of production. All the elements, requirements and provisions adopted by the manufacturer shall be documented in a systematic manner in the form of written policies and procedures, including records of results performed. This production control system shall ensure that the product is in conformity with this European Technical Approval.

The manufacturer may only use initial / raw / constituent materials stated in the technical documentation of this European Technical Approval.

The factory production control shall be in accordance with the "Control Plan of 28. June 2013 relating to the European Technical Approval ETA-13/0914 issued on 28. June 2013" which is part of the technical documentation of this European Technical Approval. The "Control Plan" is laid down in the context of the factory production control system operated by the manufacturer and deposited at the Deutsches Institut für Bautechnik.

The results of factory production control shall be recorded and evaluated in accordance with the provisions of the "Control Plan".

3.2.1.2 Other tasks of manufacturer

The manufacturer shall provide a technical datasheet and an installation guide containing at least the following information:

Technical data sheet:

1. Field of application:

Building elements in which the kit may be installed, type and properties of the building elements like minimum thickness, density, and - in case of lightweight constructions - the construction requirements.

Services which may penetrate the opening to be sealed off, type and properties of the services like material, diameter, thickness etc, necessary/allowed supports/fixings, separations etc.

Design of the penetration seal(s) including limits in size, minimum thickness, separations etc. of the penetration seal(s).

Definitions of ancillary products with clear indication whether they are generic or specific.

Environmental conditions covered by the ETA: Indoor Application without humidity exposure (Z₂)

2. Installation instruction:

- Steps to be followed
- Stipulations on maintenance, repair and replacement

The manufacturer shall, on the basis of a contract, involve a body which is approved for the tasks referred to in section 3.1 in the field of ETAG 026-2 in order to allow the manufacturer to undertake the actions laid down in section 3.2.2. For this purpose, the "control plan" referred to in sections 3.2.1.1 and 3.2.2 shall be handed over by the manufacturer to the notified body involved.

The manufacturer shall make a declaration of conformity, stating that the construction product is in conformity with the provisions of the European Technical Approval ETA-13/0914 issued on 28. June 2013.

3.2.2 Tasks of notified body

The approved body shall perform the following tasks in accordance with the provisions laid down in the control plan:

- Initial type-testing of the product
- Initial inspection of factory and factory production control
- Continuous surveillance, assessment and approval of factory production control

The notified body shall retain the essential points of its actions referred to above and state the results obtained and conclusions drawn in (a) written report (reports).

The notified product certification body involved by the manufacturer shall issue an EC certificate of conformity of the product stating the conformity with the provisions of this European Technical Approval.

In cases where the provisions of the European Technical Approval and its "Control Plan" are no longer fulfilled the certification body shall withdraw the certificate of conformity and inform the Deutsches Institut für Bautechnik without delay.

3.3 CE marking

The CE marking shall be affixed on the packaging of the kit. The marking „CE“ shall be followed by the identification number of the notified product certification body and be accompanied by the following additional information:

- the name and address of the producer (legal entity responsible for the manufacturer),
- the last two digits of the year in which the CE marking was affixed,
- the number of the EC certificate of conformity for the product,
- the number of the European Technical Approval,
- the number of the guideline for European Technical Approval,
- the name and intended use of the product,
- "see ETA-13/0914 for relevant characteristics".

For an example of the CE marking see Appendix 5.

4 Assumptions under which the fitness of the product(s) for the intended use was favourably assessed

4.1 General⁸

4.1.1 For evaluating resistance to fire of the penetration seal incorporating "BD01...-S90" or "BD01...-S120" it is assumed that

- the installation of the penetration seal does not affect the stability of the adjacent building elements – even in case of fire,
- the installations are fixed to the adjacent building elements (not to the penetration seal) in accordance with the relevant regulations in such a way that, in case of fire, no additional mechanical load is imposed on the seal,
- the support of the installations is maintained for the classification period required,
- the penetration seal complies with the specifications in this ETA and the installation was carried out in accordance with this ETA and also in accordance with the technical data sheet and the installation instructions by the manufacturer,
- damages to the penetration seal are repaired accordingly,
- the seal is installed only in the building elements specified in this ETA,
- only installations in accordance with the specifications in this ETA pass through the openings (Parts or service support constructions other than those in accordance with section 1.2 shall not pass through the penetration seal.),
- the lintel or floor above the penetration seal is designed structurally and in terms of fire protection such that no additional mechanical load (other than its own weight) is imposed on the seal,

4.1.2 This European Technical Approval does not verify the prevention of destruction of adjacent building elements with fire separating function or of the bus bar unit themselves due to distortion forces caused by extreme temperatures. These risks shall be accounted for by taking appropriate measures when designing or installing the bus bar unit.

The mounting or hanging or the execution of the bus bar trunking unit shall be implemented in such a way that the bus bar trunking unit and the fire-resistant building elements shall remain functional within a period of time which corresponds to the fire resistance period required.

4.2 Manufacturing

The Kit shall be produced in accordance with the manufacturing process deposited with Deutsches Institut für Bautechnik.

The European Technical Approval is issued for the product on the basis of agreed data and information, deposited with the Deutsches Institut für Bautechnik), which identifies the product that has been assessed and judged. Changes to the product or production process, which could result in this deposited data and information being incorrect, shall be notified to the Deutsches Institut für Bautechnik) before the changes are introduced. The Deutsches Institut für Bautechnik will decide whether or not such changes affect the ETA and consequently the validity of the CE marking on the basis of the ETA and if so whether further assessment or alterations to the ETA, shall be necessary.

4.3 Installation

The arrangement and installation of the kit shall be done in accordance with the details given in the Annexes 3 to 5 for the penetration seal(s) or the bus bar trunking system.

⁸ The assumptions are valid for mixed penetration seals. For cable penetration seals only the sections which are relevant for cables and for pipe penetration seals only the sections which are relevant for pipes shall be used.

5 Indications to the manufacturer

5.1 Packaging, transport and storage

- 5.1.1 The manufacturer's specifications for packaging, transport and storage shall be observed.
- 5.1.2 The packaging of the joint sealing material shall contain the following information:
 - Trade name or trademark or other symbol identifying the product
 - The date of manufacture (day, month, year or coded information)
- 5.1.3 The sealant shall be packed for delivery in such a way that usual delivery conditions are being complied with and that sufficient protection against the effects of normal handling is given.

5.2 Use, maintenance, repair

- 5.2.1 The fire resistance of penetration seals incorporating the kit shall not be negatively affected by future changes to buildings or building elements.
- 5.2.2 The assessment of the fitness for use is based on the assumption that damaged seals are replaced or repaired. It is also assumed that replacement of components during maintenance/repair will be undertaken using materials specified by this European Technical Approval.
- 5.3.3 In general, no maintenance work is necessary. Repair can be made by restoring damaged boards according to Appendix 1 and by using the joint sealing material according to Appendix 1.

Prof. Gunter Hoppe
Head of Department

beglaubigt:
Racinowski

Type / Manufacturer	Description
"BD01...-S90" Siemens AG Frohnhofstraße 103-107 50827 Köln DEUTSCHLAND	Kit for penetration seals of the busbar system "BD01-..." for a fire resistance period of <u>90 minutes</u> The kit consists of - a bus bar trunking unit "BD01- ..." according to Annex 2, - boards "PROMATECT-200" in accordance with ETA-07/0297 (see below) with dimensions corresponding to the size of bus bar trunking unit according to Appendices 4, 5 and 6 to 8, - a sealant called "PROMASEAL Mastic" (see below)
"BD01...-S120" Siemens AG Frohnhofstraße 103-107 50827 Köln DEUTSCHLAND	Kit for penetration seals of the busbar system "BD01-..." for a fire resistance period of <u>120 minutes</u> The kit consists of - a bus bar trunking unit "BD01- ..." according to Annex 2, - boards "PROMATECT-200" in accordance with ETA-07/0297 (see below) with dimensions corresponding to the size of bus bar trunking unit according to Appendix 6, - a sealant called "PROMASEAL Mastic" (see below)
"PROMASEAL Mastic" (as component of the kit) Promat International NV Bormstraat 24 B-2830 Tiselt BELGIEN	Sealant filled in cartridges Reaction to fire performance in accordance with EN 13501-1: Class E Further material data is deposited with the DIBt.
"PROMATECT-200" (as component of the kit) Promat International NV Bormstraat 24 B-2830 Tiselt BELGIEN	Fire protection panels "PROMATECT-200" in accordance with ETA-07/0297 Reaction to fire performance in accordance with EN 13501-1: Class A1 Thickness: 15 mm or 20 mm
"PROMATECT-H" Promat International NV Bormstraat 24 B-2830 Tiselt BELGIEN	Fire protection panels "PROMATECT-H" in accordance with ETA-06/0206 Reaction to fire performance according to EN 13501-1: Class A1 Thickness: 20 mm
gap filling material, manufacturer-independent	Dimensionally stable, non-combustible (Class A1 or A2-s1,d0 in accordance with EN 13501-1) materials, such as concrete, cement mortar or gypsum mortar or – when installing in walls – also mineral wool (fire performance Class A1 or A2 in accordance with EN 13501-1) with a melting point > 1000 °C in accordance with DIN 4102-17.
"BD01...-S90" and "BD01...-S120"	Annex 1
Appendix 1 – Description of the product and ancillary properties	

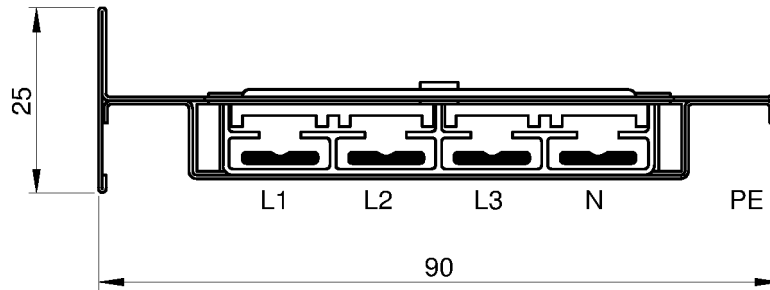

Busbar trunking system	Bar			Current in [A]
	Material	Cross-section	quantity	
BD01-40	Aluminium	1,6 x 10	4	40
BD01-63		1,6 x 10		63
BD01-100		3,5 x 10		100
BD01-125				125
BD01-160	Copper			160

Measurements and later situation of the fire protection plates

Kit	Number	Width	Length	Thickness	Position*
BD01-40-S90, BD01-40-S120, BD01-63-S90, BD01-63-S120, BD01-100-S90, BD01-100-S120, BD01-125-S90 and BD01-125-S120	2	69	≥ 500	20	outside
	2	94	≥ 500	20	outside
	2	87	≥ 100	15	inside
BD01-160-S90, BD01-160-S120	2	69	≥ 650	20	outside
	2	94	≥ 650	20	outside
	2	87	≥ 100	15	inside

* see Annex 7

Dimensions in mm

"BD01...-S90" and "BD01...-S120"

Appendix 1 – Description of the product and ancillary properties
Description of the bus bar trunking units "BD01-...S..."

Annex 2

The kit "BD01...-S90" may be installed in

Rigid walls

- of masonry, concrete, reinforced concrete, or aerated concrete
- density $\geq 630 \text{ kg/m}^3$
- thickness $\geq 100 \text{ mm}$
- The walls shall be classified according to EN 13501-2 (maximum EI 90) corresponding to the required fire resistance period.

Flexible walls

- flexible walls with a steel stud substructure and a lining on both sides made from min. 2 layers of 12,5 mm thick cementitious or gypsum based slabs with a fire reaction class A1 or A2 according to EN 13501-1

The framework shall be supplemented with additional transoms and mullions so that they form the reveal of the wall opening for the planned mixed penetration seal. The wall lining shall be attached to these steel profiles appropriately. The opening reveal shall be cladded as described below.

- flexible walls with a wood stud substructure and a lining on both sides made from min. 2 layers of 12,5 mm thick cementitious or gypsum based slabs with a fire reaction class A1 or A2 according to EN 13501-1

The distance between the wood substructure and the seal shall be $\geq 100 \text{ mm}$ and the cavity between the linings of the wall, the wood substructure and the seal shall be tightly clogged with mineral wool of fire reaction class A1 or A2 according to EN 13501-1 in a depth of minimum 100 mm. The opening reveal shall be cladded as described below.

- thickness $\geq 100 \text{ mm}$
- The walls shall be classified according to EN 13501-2 (maximum EI 90) corresponding to the required fire resistance period.
- Cladding of the opening reveal: A surrounding reveal (frame flush with the wall surface) shall be fitted in the opening in accordance with the layout of the respective wall lining (for walls without internal insulation) or made of at least 12.5 mm thick cementitious or gypsum bound sheets with fire reaction class A1 per EN 13501-1 (e. g. gypsum fibre or calcium silicate plates) (for walls with internal insulation).

Rigid floors

- of masonry, concrete, reinforced concrete or aerated concrete
- density $\geq 550 \text{ kg/m}^3$
- thickness $\geq 150 \text{ mm}$
- The floors shall be classified according to EN 13501-2 (maximum EI 90) corresponding to the required fire resistance period.

The kit "BD01...-S120" may be additionally installed in

- of masonry, concrete, reinforced concrete, or aerated concrete
- density $\geq 550 \text{ kg/m}^3$
- thickness $\geq 150 \text{ mm}$
- The floors shall be classified according to the intended fire resistance period in accordance with EN 13501-2 (maximum EI 120).

Note: This ETA does not cover the installation of the seal in special walls, i. e. in sandwich panel constructions.

"BD01...-S90" and "BD01...-S120"

Appendix 2 – Intended use
Walls and floors

Annex 3

**Fire insulation of busbar trunking unit "BD01-..."
with the Fire resistance class EI 90 according EN 13501-2
in a Flexible wall $t \geq 100$ mm**

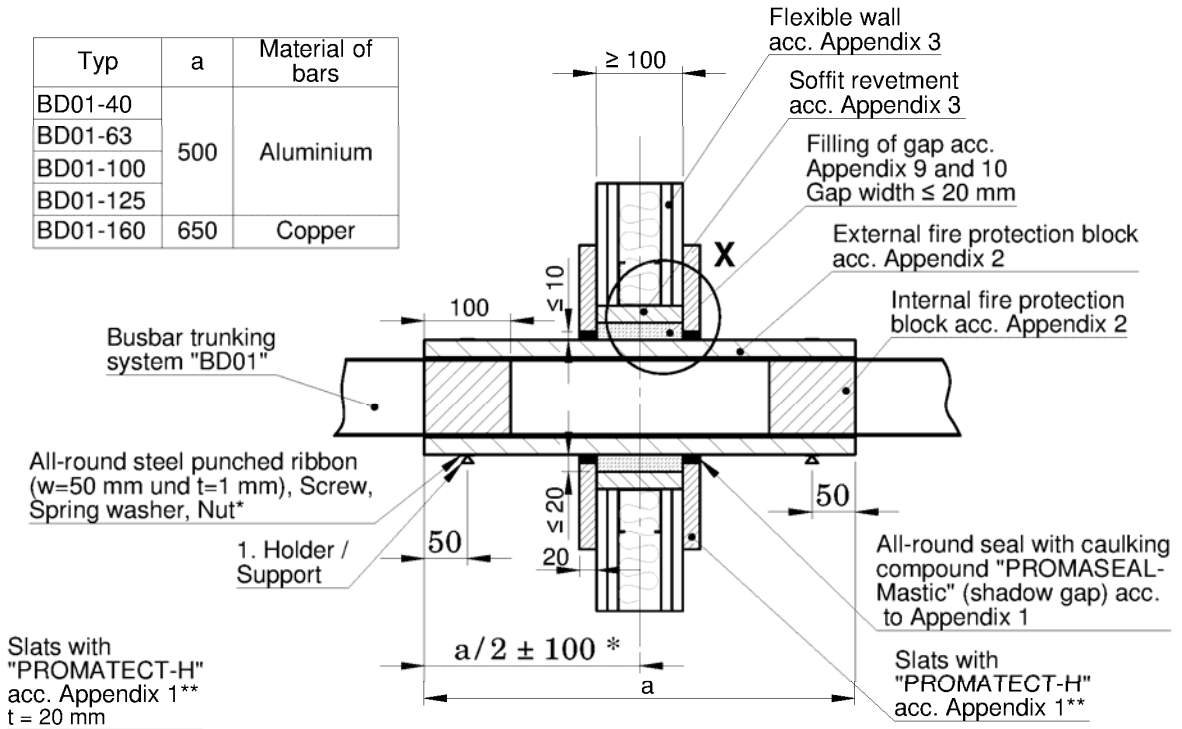

* when installing the fire protection block symmetrical to the wall, it is permissible to omit the all-round steel punched ribbon

For details on the lining of busbar trunking system, see Appendix 7 and 8

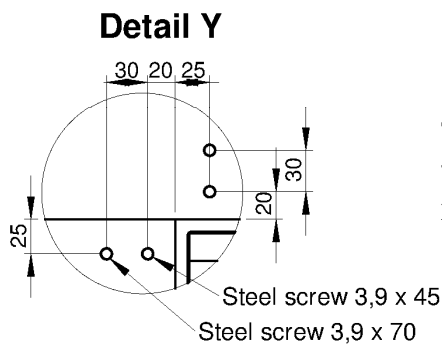
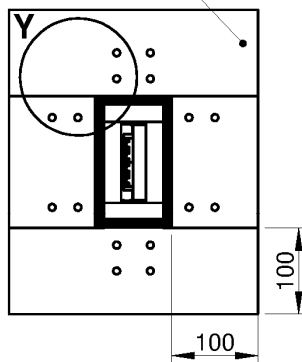

DETAIL X

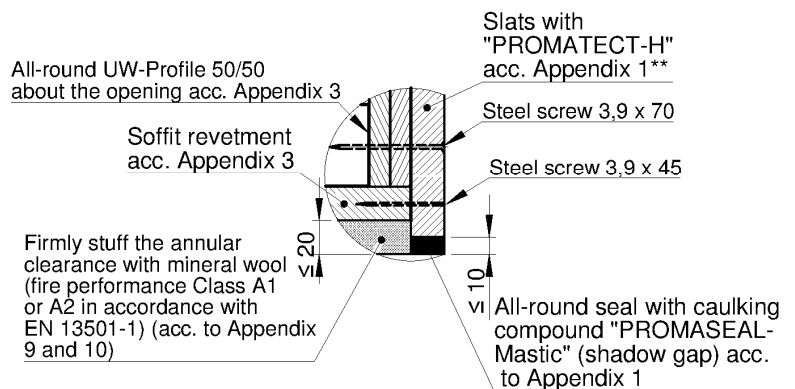

Dimension in mm

"BD01...-S90" and "BD01...-S120"

Appendix 3 – Description of the fire penetration seal by using of the system "BD01...-S90"
Installation in flexible walls acc. to Annex 3 – symmetrical and asymmetrical installation

Annex 5

**Fire insulation of busbar trunking unit "BD01-..."
with the Fire resistance class EI 90 or EI 120 according EN 13501-2
in a Solid ceiling $t \geq 100$ mm**

Typ	a	Material of bars
BD01-40	500	Aluminium
BD01-63		
BD01-100		
BD01-125		
BD01-160	650	Copper

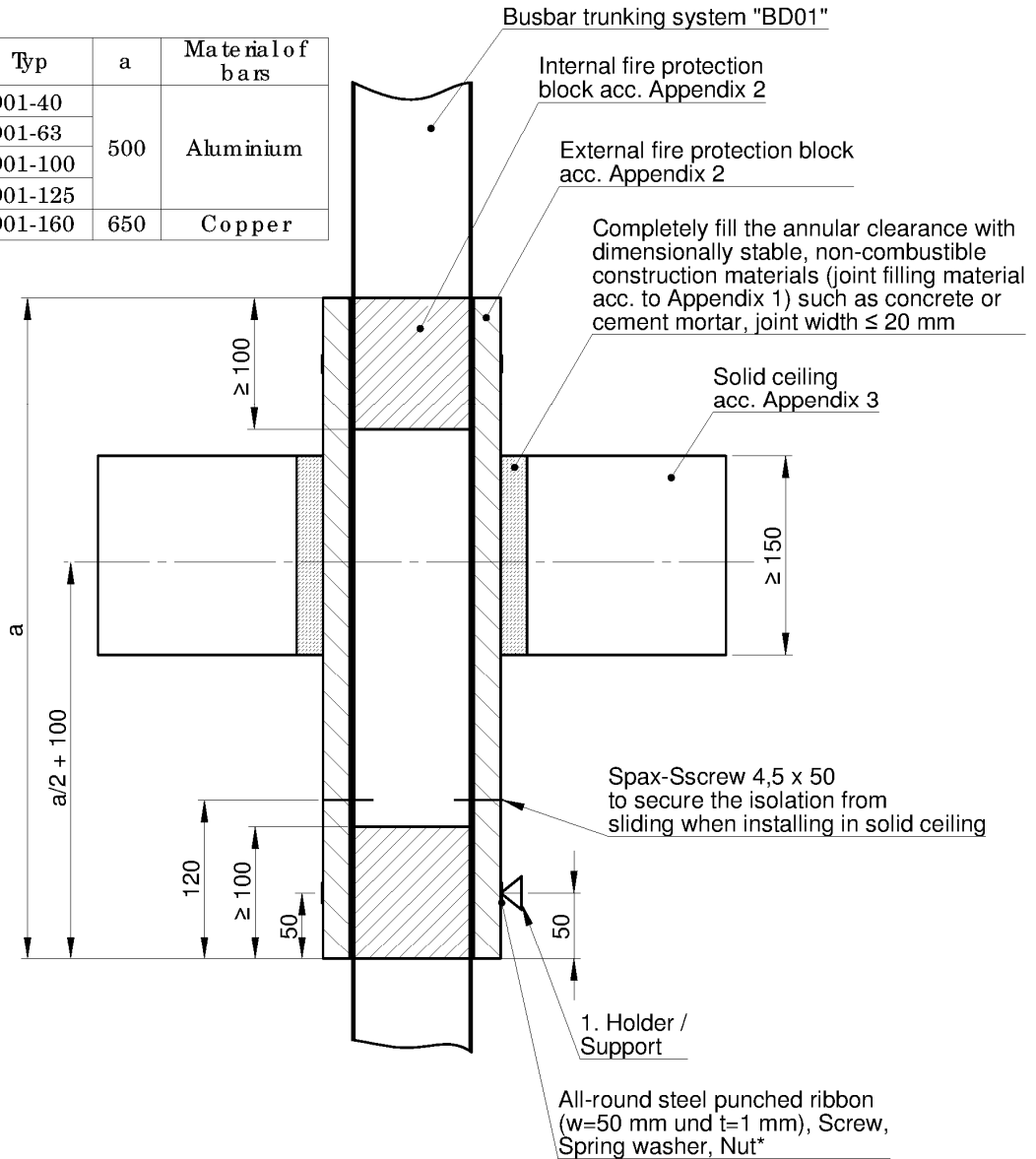

For details on the lining of busbar trunking system, see Appendix 7 and 8

* when installing the fire protection block symmetrical to the ceiling, it is permissible to omit the all-round steel punched ribbon

Dimension in mm

"BD01...-S90" and "BD01...-S120"

**Appendix 3 – Description of the fire penetration seal by using of the system
"BD01...-S90" and "BD01...-S120"**
Installation in rigid floors acc. to Annex 3 – symmetrical and asymmetrical installation

Annex 6

Lined busbar trunking system (cross-section)

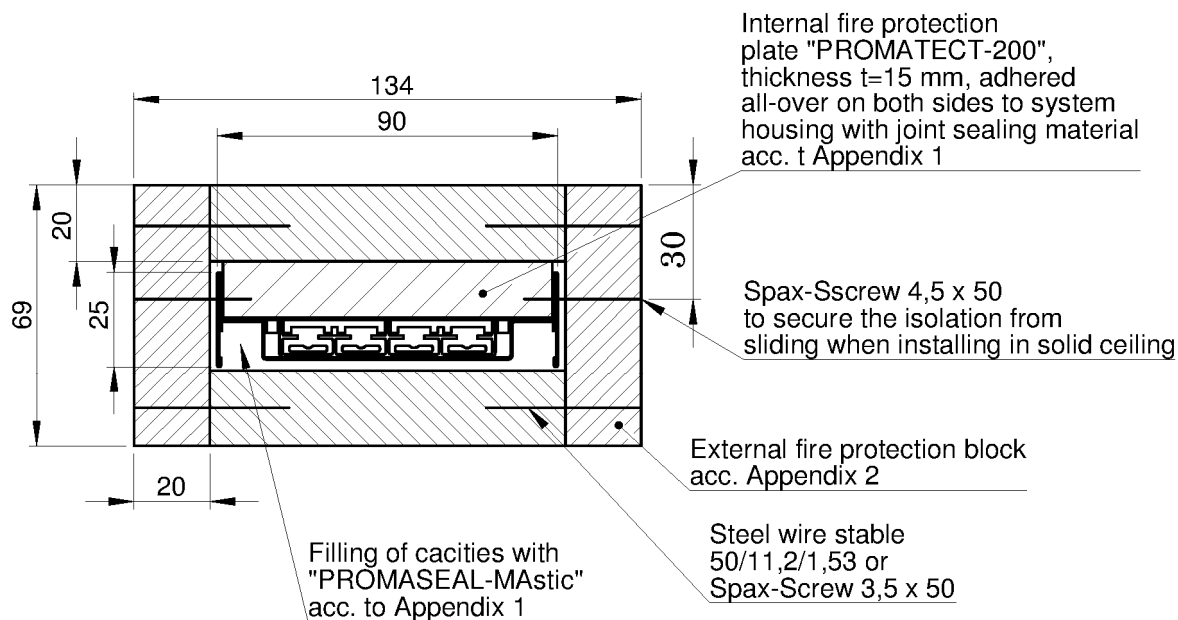

"BD01...-S90" and "BD01...-S120"

**Appendix 3 – Description of the fire penetration seal by using of the system
"BD01...-S90" and "BD01...-S120"**
Cross section

Annex 7

Lined busbar trunking system (longitudinal section)

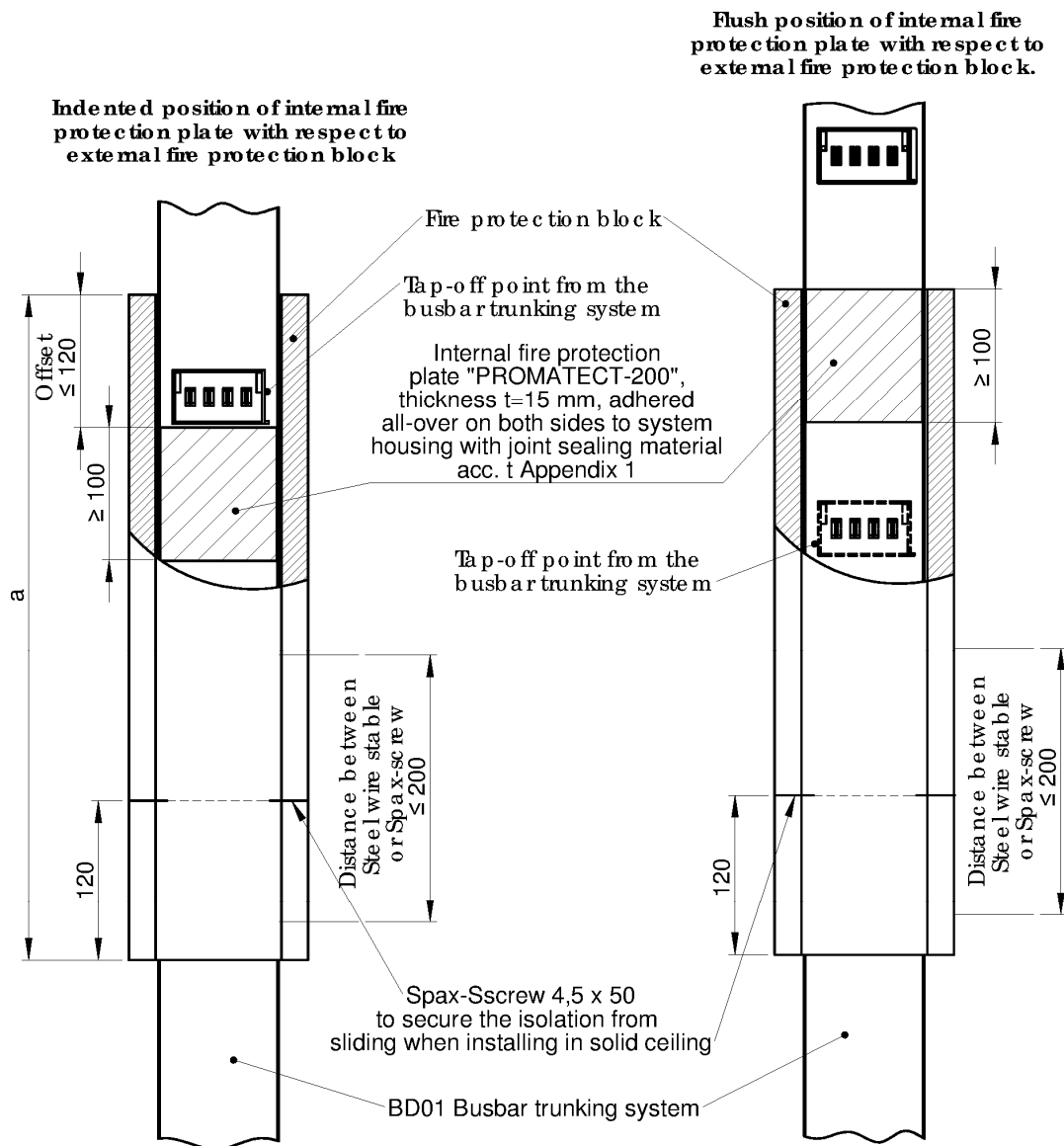

a > 500 mm for bar material Aluminium
a > 650 mm for bar material copper

Typ	a	Material of bars
BD01-40	500	Aluminium
BD01-63		
BD01-100		
BD01-125		
BD01-160	650	Copper

"BD01...-S90" and "BD01...-S120"

Appendix 3 – Description of the fire penetration seal by using of the system "BD01...-S90" and "BD01...-S120"
Longitudinal section

Annex 8

Installation of the penetration seal

1. General

- 1.1 Before installing the penetration seal of the busbar system, are to be checked for compliance (e. g. type and thickness of the wall or floor, type and dimensions of the pipes and the ambient conditions) with the provisions of section 1.2 and Annex 1 and 2.
- 1.2 It shall be ensured that the assumptions under which the fitness for use was evaluated are complied with (see section 4).
- 1.3 When starting with the installing, the surfaces of the openings for the components must be cleaned.

2. Construction of the fire protective boards on the busbar element for the penetration seal

- 2.1 The 15 mm thick fire protective boards according to Appendix 2 are arranged on one side of the busbar elements between the flanges (see Appendix 7). The boards must be adhered all over with the busbar element using the sealant "PROMASEAL Mastic" so that a tight connection is produced between the fire protective boards and the busbar element. The distance between these fire protective boards must be 300 mm to 60 mm (with aluminum bus bars) or 450 mm to 210 mm (with copper bus bars) (see Annex 7).
- 2.2 The 650 mm (with copper bus bars) or 500 mm (with aluminum bus bars) boards made of "PROMATECT-200" must be arranged on the busbar element according to the specifications in Annex 4 to 8 such that the previously constructed 15 mm thick fire protective boards are completely covered, but on both sides by not more than 120 mm. The free surfaces of the two 15 mm thick fire protective boards must first be coated all over with the sealant "PROMASEAL Mastic" according to Annex 1 so that a tight connection is produced between the internal and external fire protective boards. The external panels must be connected together using steel screws SPAX 3,5 x 50 mm or steel wire clamps 50/11.2/1.53 (see Annex 7).
- 2.3 All remaining joints must be sealed tightly against flue gas on the front side of the lining using the sealant "PROMASEAL Mastic".

3. Installation of the lined busbar trunking system in walls

- 3.1 The busbar trunking system provided with the lining must be inserted upright or flat into the opening for the component such that the overhang of the lining on each side of the wall is at least 100 mm or 225 mm (see Annex 4 and 5). Circumferential perforated steel strips 50 mm wide and 1 mm thick should be provided 50 mm from the end of the lining on both sides of the wall to additionally secure the boards. If the lining is installed symmetrical to the plane of the wall, it is permissible to omit the circumferential perforated steel strips. With symmetrical installation of the external fire protective block, the internal fire protective boards can be shifted in the direction of the opening for the component. The distance between the internal fire protective boards must then be at least 60 mm or 210 mm. With asymmetrical installation of the external fire protective block, the internal fire protective boards must terminate on the front side of the fire protective block (see Annex 8).
- 3.2 When installing in rigid walls, the all-round joint (max. 20 mm wide) between the lining of the busbar trunking system and the wall surface must be completely filled in the thickness of the component with dimensionally stable, non-combustible (Class A1 or A2-s1,d0 in accordance with EN 13501-1) construction materials such as concrete, cement mortar or gypsum mortar. When installing in light partitions, this joint must be completely filled with non-combustible (fire performance Class A1 or A2 in accordance with EN 13501-1) mineral wool (melting point > 1000 °C in accordance with DIN 4102-17). This type of joint filling may also be used as an option when installing in rigid walls.
- 3.3 At least the 20 mm thick panels "PROMATECT" must subsequently be fitted on both sides of the wall according to Annex 1. For this, four strips of these panels (at least 100 mm wide) must be secured to the wall all around the opening for the component using at least 4 steel screws per slat (see Annex 4 and 5). The slats can be omitted in the case of a wall thickness > 140 mm. In addition, the transition between lining and slat or wall must be sealed all-round using the sealing compound the sealant "PROMASEAL Mastic".

"BD01...-S90" and "BD01...-S120"

Appendix 4 – Installation of the product and ancillary properties

Annex 9

4. Installation of the lined busbar trunking system in floors

- 4.1 The busbar trunking system provided with the lining must be inserted into the opening for the component such that the overhang of the lining on each side of the floor is at least 150 mm or 225 mm (see Annex 6). Circumferential perforated steel strips 50 mm wide and 1 mm thick should be provided 50 mm from the end of the lining on both sides of the floor to additionally secure the boards. If the lining is installed symmetrical to the plane of the floor, it is permissible to omit the circumferential perforated steel strips.
- 4.2 The all-round joint (max. 20 mm wide) between the busbar trunking system and floor surface must be completely filled in the thickness of the component with dimensionally stable, non-combustible (Class A1 or A2-s1,d0 in accordance with EN 13501-1) construction materials such as concrete, cement mortar or gypsum mortar.
- 4.3 On the underside of the floor the lining of the busbar trunking system shall be fixed at the busbar element by using steel screws SPAX 3.5 x 50 mm.

"BD01...-S90" and "BD01...-S120"

Appendix 4 – Installation of the product and ancillary properties

Annex 10

 XXXX
Siemens AG Frohnhofstraße 103-107 50827 Köln 13 1234-CPD-0321
ETA-13/0914 ETAG N° 026 part 2 "BD01...-S..." für die Verwendung in Abschottungen des Stromschiensystems "BD01-..." Penetration seal for bus bar systems "BD01-..."

"CE"-Zeichen / "CE" marking

Identifizierungsnummer der notifizierten Stelle (für Konformitätsbescheinigungssystem 1) / Identification number of notified certification body

Name und Anschrift des Herstellers oder seines autorisierten Vertreters (verantwortliche juristische Person) / Name and address of the producer (legal entity responsible for the manufacturer)

Die letzten beiden Ziffern des Jahres, in dem die CE-Kennzeichnung angebracht wurde / Two last digits of year of affixing CE marking

Nummer des EG-Konformitätszertifikats / Number of EC certificate of conformity

Nummer der ETA / ETA number

Nummer der Leitlinie / ETAG number

Produktbezeichnung (Handelsname) / Designation of the product (trade name)

Produktbezeichnung der Komponente (Handelsname) / Designation of the component (trade name)

Nutzungskategorie / use category

Für weitere relevante Produktmerkmale (z. B. Feuerwiderstandsklasse, Abgabe gefährlicher Stoffe) s. ETA-13/0914 / See ETA-13/0914 for other relevant characteristics (i. e. fire resistance class, dangerous substances)

"BD01...-S90" and "BD01...-S120"

Appendix 5 – Example for CE-marking

Annex 11

Abbreviations

- FWKL:** maximum fire resistance class; If installed in building elements of the same type, thickness, density and with the same structure, but with a lower fire resistance class, the fire resistance class of the penetration seal is reduced to the fire resistance class of the building element.
- LTW:** flexible wall according to annex 8
- MW:** rigid wall according to annex 8
- D:** rigid floor according to annex 8
- d_w:** wall thickness
- d_p:** floor thickness

Standards

- EN 13501-2:2010-02** Fire classification of construction products and building elements – Part 2: Classification using test data from resistance to fire tests, excluding ventilation services
- EN 13501-1:2007** Fire classification of construction products and building elements – Part 1: Classification using test data from reaction to fire tests
- prEN 1366-3:2007-07** Document from CEN TC 127 for formal vote (document N 185); title see EN 1366-3:2009-07
- EN 1366-3:2009-07** Fire resistance tests for service installations – Part 3: Penetration seals
- EN 13162: 2008** Thermal insulation products for buildings – Factory made mineral wool (MW) products – Specification

Other documents

- ETAG 026-2** Guideline for European Technical Approval of Fire Stopping and Fire Sealing Products, Part 2, Penetration Seals (edition January 2008)
- EOTA TR 024** Characterisation, Aspects of Durability and Factory Production Control for Reactive Materials, Components and Products (edition November 2006)

"BD01...-S90" and "BD01...-S120"

Appendix 6 – Abbreviations and reference documents

Annex 12