



European Technical Approval ETA-13/0364

English translation prepared by DIBt - Original version in German language

Handelsbezeichnung
Trade name

JCP Option 1 Throughbolt und Option 1 Throughbolt ITS
JCP Option 1 Throughbolt and Option 1 Throughbolt ITS

Zulassungsinhaber
Holder of approval

JCP Construction Products
Unit 14 Teddington Business Park
Station Road
TEDDINGTON, MIDDLESEX TW11 9BQ
GROSSBRITANNIEN

Zulassungsgegenstand
und Verwendungszweck
*Generic type and use
of construction product*

Kraftkontrolliert spreizender Dübel zur Verankerung im Beton
Torque controlled expansion anchor for use in concrete

Geltungsdauer:
Validity: vom
from
bis
to

30 May 2013
15 May 2018

Herstellwerk
Manufacturing plant

Plant2, Germany

Diese Zulassung umfasst
This Approval contains

41 Seiten einschließlich 33 Anhänge
41 pages including 33 annexes

I LEGAL BASES AND GENERAL CONDITIONS

- 1 This European technical approval is issued by Deutsches Institut für Bautechnik in accordance with:
 - Council Directive 89/106/EEC of 21 December 1988 on the approximation of laws, regulations and administrative provisions of Member States relating to construction products¹, modified by Council Directive 93/68/EEC² and Regulation (EC) N° 1882/2003 of the European Parliament and of the Council³;
 - *Gesetz über das In-Verkehr-Bringen von und den freien Warenverkehr mit Bauprodukten zur Umsetzung der Richtlinie 89/106/EWG des Rates vom 21. Dezember 1988 zur Angleichung der Rechts- und Verwaltungsvorschriften der Mitgliedstaaten über Bauprodukte und anderer Rechtsakte der Europäischen Gemeinschaften (Bauproduktengesetz - BauPG) vom 28. April 1998⁴, as amended by Article 2 of the law of 8 November 2011⁵;*
 - Common Procedural Rules for Requesting, Preparing and the Granting of European technical approvals set out in the Annex to Commission Decision 94/23/EC⁶;
 - Guideline for European technical approval of "Metal anchors for use in concrete - Part 2: Torque controlled expansion anchors", ETAG 001-02.
- 2 Deutsches Institut für Bautechnik is authorized to check whether the provisions of this European technical approval are met. Checking may take place in the manufacturing plant. Nevertheless, the responsibility for the conformity of the products to the European technical approval and for their fitness for the intended use remains with the holder of the European technical approval.
- 3 This European technical approval is not to be transferred to manufacturers or agents of manufacturers other than those indicated on page 1, or manufacturing plants other than those indicated on page 1 of this European technical approval.
- 4 This European technical approval may be withdrawn by Deutsches Institut für Bautechnik, in particular pursuant to information by the Commission according to Article 5(1) of Council Directive 89/106/EEC.
- 5 Reproduction of this European technical approval including transmission by electronic means shall be in full. However, partial reproduction can be made with the written consent of Deutsches Institut für Bautechnik. In this case partial reproduction has to be designated as such. Texts and drawings of advertising brochures shall not contradict or misuse the European technical approval.
- 6 The European technical approval is issued by the approval body in its official language. This version corresponds fully to the version circulated within EOTA. Translations into other languages have to be designated as such.

¹ Official Journal of the European Communities L 40, 11 February 1989, p. 12
² Official Journal of the European Communities L 220, 30 August 1993, p. 1
³ Official Journal of the European Union L 284, 31 October 2003, p. 25
⁴ *Bundesgesetzblatt Teil I 1998*, p. 812
⁵ *Bundesgesetzblatt Teil I 2011*, p. 2178
⁶ Official Journal of the European Communities L 17, 20 January 1994, p. 34

II SPECIFIC CONDITIONS OF THE EUROPEAN TECHNICAL APPROVAL

1 Definition of product and intended use

1.1 Definition of the construction product

The JCP Option 1 Throughbolt and Option 1 Throughbolt ITS is an anchor made of galvanised steel or made of stainless steel or high corrossions resistant steel which is placed into a drilled hole and anchored by torque-controlled expansion. This European technical approval comprises the following anchor types:

- Anchor type Option 1 Throughbolt with external thread, washer and hexagon nut, sizes M8 to M27,
- Anchor type Option 1 Throughbolt ITS S with internal thread, hexagon head nut and washer S-IG, sizes M6 to M12,
- Anchor type Option 1 Throughbolt ITS SK with internal thread, countersunk head screw and countersunk washer SK-IG, sizes M6 to M12,
- Anchor type Option 1 Throughbolt ITS B with internal thread, hexagon nut and washer MU-IG, sizes M6 to M12.

An illustration of the product and intended use is given in Annexes 1, 2 and 20.

1.2 Intended use

The anchor is intended to be used for anchorages for which requirements for mechanical resistance and stability and safety in use in the sense of the Essential Requirements 1 and 4 of Council Directive 89/106 EEC shall be fulfilled and failure of anchorages made with these products would cause risk to human life and/or lead to considerable economic consequences.

The anchor may be used for anchorages with requirements related to resistance to fire.

The anchor is to be used only for anchorages subject to static or quasi-static loading in reinforced or unreinforced normal weight concrete of strength classes C20/25 at least and C50/60 at most according to EN 206:2000-12. It may be anchored in cracked and non-cracked concrete.

Anchor made of galvanised steel:

The anchor made of galvanised steel may only be used in structures subject to dry internal conditions.

Anchor made of stainless steel

The anchor made of stainless steel may be used in structures subject to dry internal conditions and also in structures subject to external atmospheric exposure (including industrial and marine environment), or exposure in permanently damp internal conditions, if no particular aggressive conditions exist. Such particular aggressive conditions are e.g. permanent, alternating immersion in seawater or the splash zone of seawater, chloride atmosphere of indoor swimming pools or atmosphere with extreme chemical pollution (e. g. in desulphurization plants or road tunnels where de-icing materials are used).

Anchor made of high corrosion resistant steel

The anchor made of high corrosion resistant steel may be used in structures subject to dry internal conditions and also in structures subject to external atmospheric exposure, in permanently damp internal conditions or in other particular aggressive conditions. Such particular aggressive conditions are e.g. permanent, alternating immersion in seawater or the splash zone of seawater, chloride atmosphere of indoor swimming pools or atmosphere with chemical pollution (e.g. in desulphurization plants or road tunnels where de-icing materials are used).

The provisions made in this European technical approval are based on an assumed working life of the anchor of 50 years. The indications given on the working life cannot be interpreted as a guarantee given by the producer, but are to be regarded only as a means for choosing the right products in relation to the expected economically reasonable working life of the works.

2 Characteristics of the product and methods of verification

2.1 Characteristics of the product

The anchor corresponds to the drawings and provisions given in the Annexes. The characteristic material values, dimensions and tolerances of the anchor not given in the Annexes shall correspond to the respective values laid down in the technical documentation⁷ of this European technical approval.

Regarding the requirements concerning safety in case of fire it is assumed that the anchor meets the requirements of class A1 in relation to reaction to fire in accordance with the stipulations of the Commission decision 96/603/EC, amended by 2000/605/EC.

The characteristic values for the design of anchorages are given in the Annexes.

Each JCP Option 1 Throughbolt is marked in accordance with Annex 3. Each JCP Option 1 Throughbolt ITS is marked in accordance with Annex 21.

The anchor shall only be packaged and supplied as a complete unit.

2.2 Methods of verification

The assessment of fitness of the anchor for the intended use in relation to the requirements for mechanical resistance and stability and safety in use in the sense of the Essential Requirements 1 and 4 has been made in accordance with the "Guideline for European technical approval of Metal Anchors for Use in Concrete", Part 1 "Anchors in general" and Part 2 "Torque-controlled expansion anchors", on the basis of Option 1.

The assessment of the anchor for the intended use in relation to the requirements for resistance to fire has been made in accordance with the technical Report TR 020 "Evaluation of anchorages in concrete concerning resistance to fire".

In addition to the specific clauses relating to dangerous substances contained in this European technical approval, there may be other requirements applicable to the products falling within its scope (e.g. transposed European legislation and national laws, regulations and administrative provisions). In order to meet the provisions of the Construction Products Directive, these requirements need also to be complied with, when and where they apply.

⁷ The technical documentation of this European technical approval is deposited at the Deutsches Institut für Bautechnik and, as far as relevant for the tasks of the approved bodies involved in the attestation of conformity procedure, is handed over to the approved bodies.

3 Evaluation and attestation of conformity and CE marking

3.1 System of attestation of conformity

According to the decision 96/582/EG of the European Commission⁸ the system 2(i) (referred to as system 1) of attestation of conformity applies.

System 1: Certification of the conformity of the product by an approved certification body on the basis of:

- (a) Tasks for the manufacturer:
 - (1) factory production control;
 - (2) further testing of samples taken at the factory by the manufacturer in accordance with a prescribed control plan;
- (b) Tasks for the approved body:
 - (3) initial type-testing of the product;
 - (4) initial inspection of factory and of factory production control;
 - (5) continuous surveillance, assessment and approval of factory production control.

Note: Approved bodies are also referred to as "notified bodies".

3.2 Responsibilities

3.2.1 Tasks of the manufacturer

3.2.1.1 Factory production control

The manufacturer shall exercise permanent internal control of production. All the elements, requirements and provisions adopted by the manufacturer shall be documented in a systematic manner in the form of written policies and procedures, including records of results performed. This production control system shall insure that the product is in conformity with this European technical approval.

The manufacturer may only use initial/ raw/ constituent materials stated in the technical documentation of this European technical approval.

The factory production control shall be in accordance with the control plan which is part of the technical documentation of this European technical approval. The control plan is laid down in the context of the factory production control system operated by the manufacturer and deposited at Deutsches Institut für Bautechnik⁹.

The results of factory production control shall be recorded and evaluated in accordance with the provisions of the control plan.

3.2.1.2 Other tasks for the manufacturer

The manufacturer shall, on the basis of a contract, involve a body which is approved for the tasks referred to in section 3.1 in the field of anchors in order to undertake the actions laid down in section 3.2.2. For this purpose, the control plan referred to in sections 3.2.1.1 and 3.2.2 shall be handed over by the manufacturer to the approved body involved.

The manufacturer shall make a declaration of conformity, stating that the construction product is in conformity with the provisions of this European technical approval.

⁸ Official Journal of the European Communities L 254 of 08.10.1996.

⁹ The control plan is a confidential part of the documentation of the European technical approval, but not published together with the European technical approval and only handed over to the approved body involved in the procedure of attestation of conformity.
See section 3.2.2.

3.2.2 Tasks for the approved bodies

The approved body shall perform the

- initial type-testing of the product,
 - initial inspection of factory and of factory production control,
 - continuous surveillance, assessment and approval of factory production control
- in accordance with the provisions laid down in the control plan.

The approved body shall retain the essential points of its actions referred to above and state the results obtained and conclusions drawn in a written report.

The approved certification body involved by the manufacturer shall issue an EC certificate of conformity of the product stating the conformity with the provisions of this European technical approval.

In cases where the provisions of the European technical approval and its control plan are no longer fulfilled the certification body shall withdraw the certificate of conformity and inform Deutsches Institut für Bautechnik without delay.

3.3 CE marking

The CE marking shall be affixed on each packaging of the anchor. The letters "CE" shall be followed by the identification number of the approved certification body, where relevant, and be accompanied by the following additional information:

- the name and address of the holder of the approval (legal entity responsible for the manufacturer),
- the last two digits of the year in which the CE marking was affixed,
- the number of the EC certificate of conformity for the product,
- the number of the European technical approval,
- the number of the guideline for European technical approval
- use category (ETAG 001-1 Option 1),
- size.

4 Assumptions under which the fitness of the product for the intended use was favourably assessed

4.1 Manufacturing

The European technical approval is issued for the product on the basis of agreed data/information, deposited with Deutsches Institut für Bautechnik, which identifies the product that has been assessed and judged. Changes to the product or production process, which could result in this deposited data/information being incorrect, should be notified to Deutsches Institut für Bautechnik before the changes are introduced. Deutsches Institut für Bautechnik will decide whether or not such changes affect the European technical approval and consequently the validity of the CE marking on the basis of the European technical approval and if so whether further assessment or alterations to the European technical approval shall be necessary.

4.2 Design of anchorages

The fitness of the anchor for the intended use is given under the following conditions:

The anchorages are designed either in accordance with

- ETAG 001 "Guideline for European technical approval of Metal Anchors for use in concrete", Annex C, method A
- or in accordance with

- CEN/TS 1992-4:2009, design method A

under the responsibility of an engineer experienced in anchorages and concrete work.

Verifiable calculation notes and drawings are taking account of the loads to be anchored.

The position of the anchor is indicated on the design drawings (e.g. position of the anchor relative to reinforcement or to supports).

The design of anchorages under fire exposure has to consider the conditions given in the technical Report TR 020 "Evaluation of anchorages in concrete concerning resistance to fire". The relevant characteristic anchor values are given in Annexes. The design method covers anchors with a fire attack from one side only. If the fire attack is from more than one side, the design method may be taken only, if the edge distance of the anchor is $c \geq 300$ mm.

4.3 Installation of anchors

The fitness for use of the anchor can only be assumed if the anchor is installed as follows:

- Anchor installation carried out by appropriately qualified personnel and under the supervision of the person responsible for technical matters of the site,
- Use of the anchor only as supplied by the manufacturer without exchanging the components of an anchor,
- For anchor version Option 1 Throughbolt ITS B according to Annex 20 the commercial standard rod may only be used if the following requirements are fulfilled:
 - Material, Dimensions and mechanical properties according to Annex 22, Table 22,
 - Confirmation of material and mechanical properties of the metal parts by inspection certificate 3.1 according to EN 10204:2004, the documents should be stored,
 - Use of the hexagon nut and washer with special coating as supplied by the holder of the approval.
- Anchor installation in accordance with the manufacturer's specifications and drawings and using the appropriate tools,
- Checks before placing the anchor to ensure that the strength class of the concrete in which the anchor is to be placed is in the range given and is not lower than that of the concrete to which the characteristic loads apply,
- Check of concrete being well compacted, e.g. without significant voids,
- Edge distances and spacing not less than the specified values without minus tolerances,
- Positioning of the drill holes without damaging the reinforcement,
- In case of aborted hole: new drilling at a minimum distance away of twice the depth of the aborted hole or smaller distance if the aborted drill hole is filled with high strength mortar and if under shear or oblique tension load it is not in the direction of load application,

European technical approval

ETA-13/0364

English translation prepared by DIBt

Page 8 of 41 | 30 May 2013

- Cleaning of the hole of drilling dust,
- Anchor installation such that the effective anchorage depth is complied with. This compliance is ensured when the embedment mark of the anchor does no more exceed the concrete surface,
- Application of the torque moment given in the Annexes using a calibrated torque wrench.

5 Indications to the manufacturer

The manufacturer is responsible to ensure that the information on the specific conditions according to 1 and 2 including Annexes referred to as well as sections 4.2 and 4.3 is given to those who are concerned. This information may be made by reproduction of the respective parts of the European technical approval. In addition all installation data shall be shown clearly on the package and/or on an enclosed instruction sheet, preferably using illustration(s).

The minimum data required are:

- Diameter of drill bit,
- Thread diameter,
- Maximum diameter of clearance hole in the fixture,
- Maximum thickness of the fixture,
- Minimum effective anchorage depth,
- Minimum hole depth,
- Torque moment,
- Information on the installation procedure, including cleaning of the hole, preferably by means of an illustration,
- Reference to any special installation equipment needed,
- Identification of the manufacturing batch.

All data shall be presented in a clear and explicit form.

Uwe Bender
Head of Department

beglaubigt:
Baderschneider

Option 1 Throughbolt (Annex 2 to Annex 19)

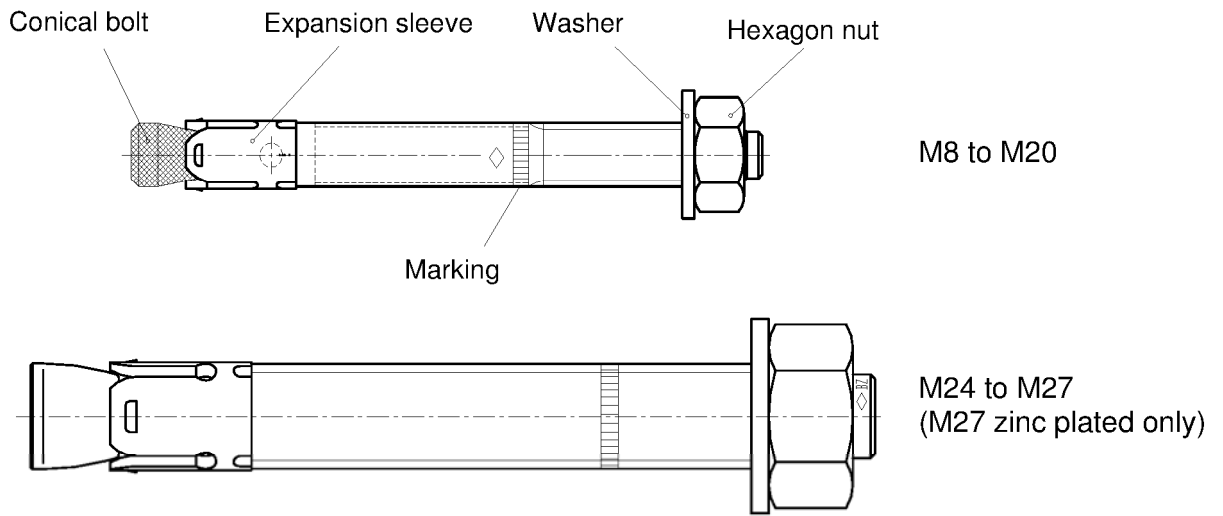

Option 1 Throughbolt ITS M6 to M12 (from Annex 20)

Anchor system Option 1 Throughbolt ITS S



Anchor system Option 1 Throughbolt ITS SK



Anchor system Option 1 Throughbolt ITS B

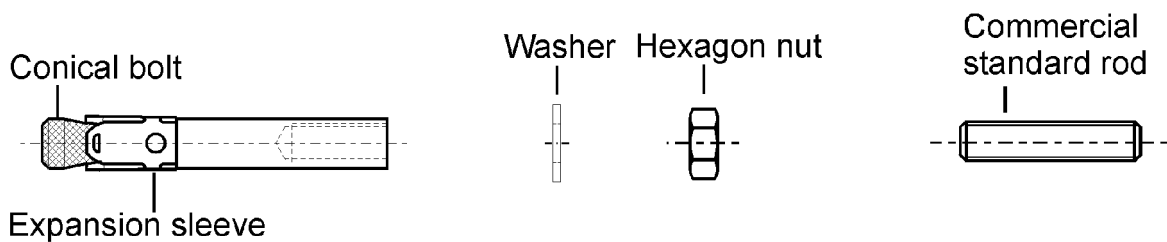

JCP Option 1 Throughbolt and Option 1 Throughbolt ITS

Product

Annex 1

Intended use Option 1 Throughbolt

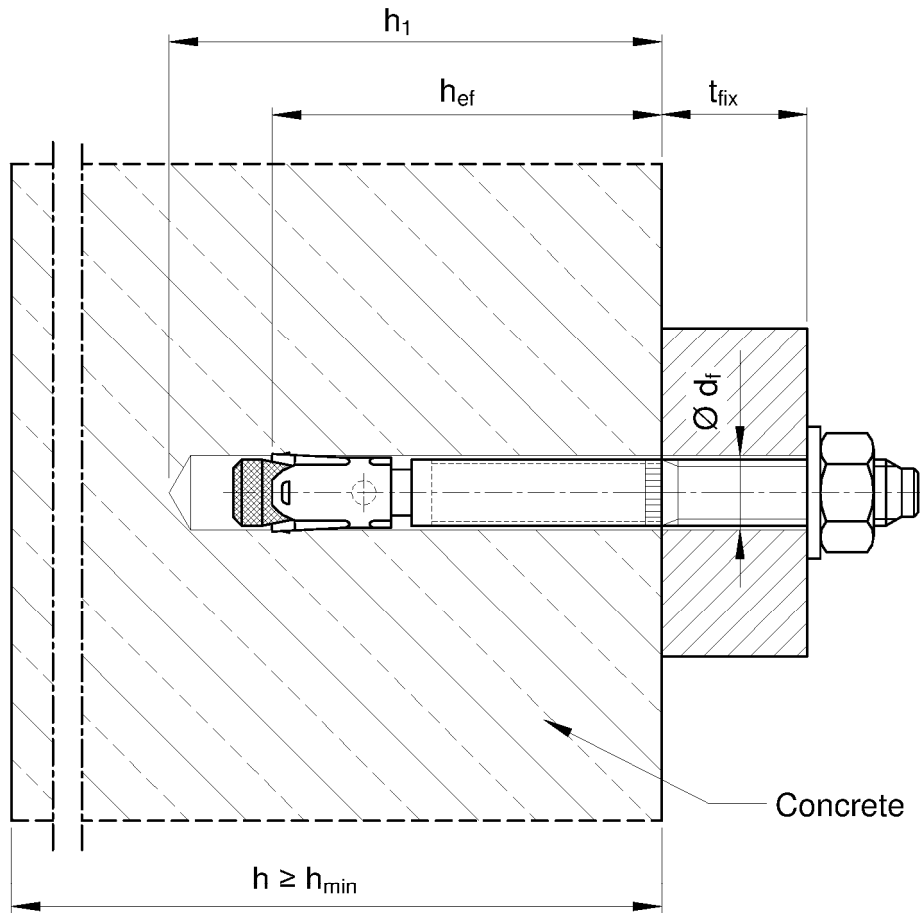

Electronic copy of the ETA by DIBt: ETA-13/0364

JCP Option 1 Throughbolt and Option 1 Throughbolt ITS

Intended use Option 1 Throughbolt

Annex 2

Anchor size Option 1 Throughbolt M8 to M20:

Marking: e.g.: \diamond BZ M10-15

- \diamond Identifying mark of manufacturing plant
- BZ Trade name
- M10 Thread diameter (alternatively at the expansion sleeve)
- 15 Maximum thickness of fixture

- A4 Additional marking of stainless steel A4
- HCR Additional marking of high corrosion resistant steel HCR

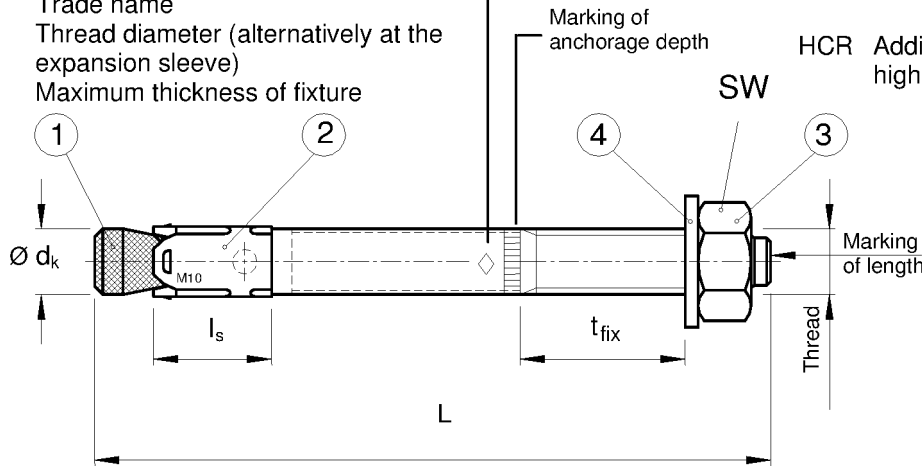

Anchor size Option 1 Throughbolt M24 and M27:

Expansion sleeve:

- \diamond Identifying mark of manufacturing plant
- A4 Additional marking of stainless steel A4

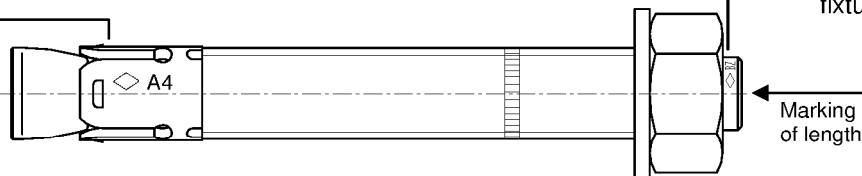

- Bolt: e.g.: \diamond BZ M24-30
- \diamond Identifying mark of manufacturing plant
- BZ Trade name
- M24 Thread diameter
- 30 Maximum thickness of fixture



Marking of length ¹⁾	C (c)	D (d)	E (e)	F (f)	G (g)	H (h)	I (i)	J (j)	K (k)	L (l)	M (m)
Length of anchor min \geq	63,5	76,2	88,9	101,6	114,3	127,0	139,7	152,4	165,1	177,8	190,5
Length of anchor max $<$	76,2	88,9	101,6	114,3	127,0	139,7	152,4	165,1	177,8	190,5	203,2

Marking of length ¹⁾	N (n)	O (o)	P (p)	Q (q)	R (r)	S (s)	T (t)	U (u)	V (v)	W (w)	X (x)	Y (y)	Z (z)
Length of anchor min \geq	203,2	215,9	228,6	241,3	254,0	279,4	304,8	330,2	355,6	381,0	406,4	431,8	457,2
Length of anchor max $<$	215,9	228,6	241,3	254,0	279,4	304,8	330,2	355,6	381,0	406,4	431,8	457,2	483,0

¹⁾ Letters in brackets for anchor size 70 M12

Table 1: Anchor dimensions, Option 1 Throughbolt

Anchor size		M8	M10	70 M12	M16	M20	M24	125 M24	M27	
1	Conical bolt									
	Thread	M8	M10	M12	M16	M20	M24	M24	M27	
	$\varnothing d_k =$	7,9	9,8	12,0	15,7	19,7	24	24	28	
	$t_{fix} \leq$	3000	3000	3000	3000	3000	3000	3000	3000	
	Steel, zinc plated	L max	3065	3080	3095	3120	3137	3161	-	3178
Stainless steel A4, HCR	L max	3065	3080	3095	3120	3137	3153	3178	-	
2	Expansion sleeve	$l_s =$	14,5	18,5	22	24,3	28	32	32	36
3	Hexagon nut	SW	13	17	19	24	30	36	36	41
4	Washer		see Table 2							

Dimensions in mm

JCP Option 1 Throughbolt and Option 1 Throughbolt ITS

Anchor dimensions, Option 1 Throughbolt

Annex 3

Table 2: Materials, Option 1 Throughbolt

Part	Anchor size	Steel, zinc plated M8 to M20	Steel, zinc plated M24 and M27	Stainless steel A4	High corrosion resistant steel (HCR)
1	Conical bolt	Cold formed or machined steel, Cone plastic coated (M8 to M20)	Threaded bolt, steel property class 8.8, EN ISO 898-1 Threaded cone, steel, property class 8, EN ISO 898-2	Stainless steel 1.4401, 1.4404, 1.4571 or 1.4578, EN 10088 Cone plastic coated	High corrosion resistant steel 1.4529 or 1.4565, EN 10088 Cone plastic coated
2	Expansion sleeve	Steel acc. to EN 10088, material No. 1.4301 or 1.4401 for M8-M20; Steel EN 10139 for M24 and M27		Stainless steel 1.4401 or 1.4571, EN 10088	Stainless steel 1.4401 or 1.4571, EN 10088
3	Hexagon nut	Property class 8 acc. to EN ISO 898-2, galvanised, coated		ISO 3506, property class 70, stainless steel 1.4401 or 1.4571, EN 10088, coated	ISO 3506, property class 70, high corrosion resistant steel 1.4529 or 1.4565, EN 10088, coated
4	Washer acc. to EN ISO 7089, or EN ISO 7093, or EN ISO 7094	Steel, galvanised		Stainless steel 1.4401 or 1.4571, EN 10088	High corrosion resistant steel 1.4529 or 1.4565, EN 10088

JCP Option 1 Throughbolt and Option 1 Throughbolt ITS

Materials, Option 1 Throughbolt

Annex 4

Table 3: Installation parameters, Option 1 Throughbolt

Anchor size			M8	M10	70 M12	M16	M20	M24	125 M24	M27	
Nominal drill hole diameter	d_0	[mm]	8	10	12	16	20	24	24	28	
Cutting diameter of drill bit	$d_{cut} \leq$	[mm]	8,45	10,45	12,5	16,5	20,55	24,55	24,55	28,55	
Depth of drill hole	Steel, zinc plated	$h_1 \geq$	[mm]	60	75	90	110	125	145	-	160
	Stainless steel A4, HCR	$h_1 \geq$	[mm]	60	75	90	110	125	130	160	-
Effective anchorage depth	Steel, zinc plated	h_{ef}	[mm]	46	60	70	85	100	115	-	125
	Stainless steel A4, HCR	h_{ef}	[mm]	46	60	70	85	100	100	125	-
Installation torque	Steel, zinc plated	T_{inst}	[Nm]	20	25	45	90	160	200	-	300
	Stainless steel A4, HCR	T_{inst}	[Nm]	20	35	50	110	200	200	290	-
Diameter of clearance hole in the fixture	$d_f \leq$	[mm]	9	12	14	18	22	26	26	30	

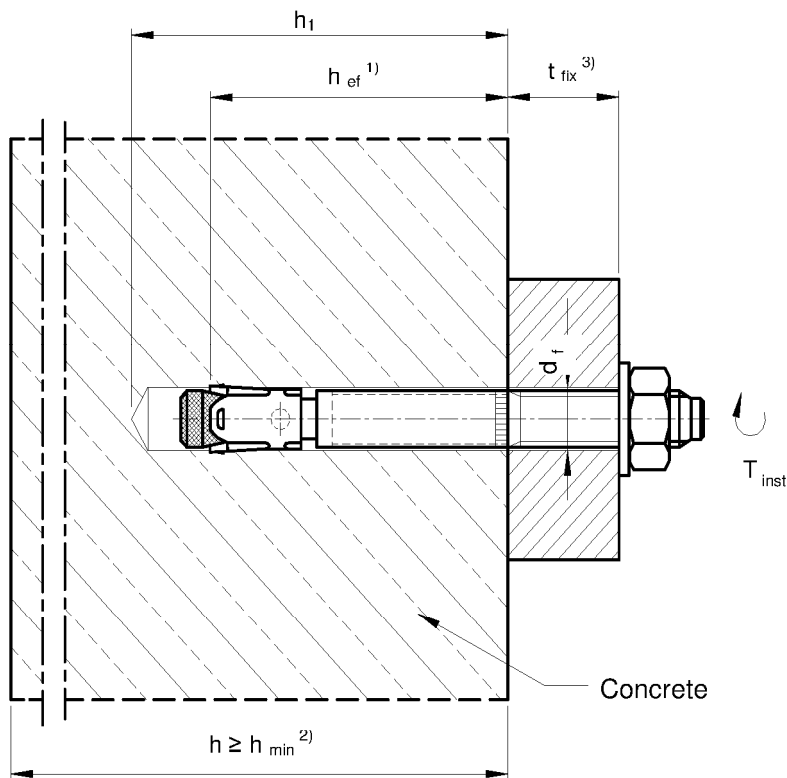

- 1) Effective anchorage depth h_{ef}
- 2) Minimum thickness of concrete member h_{min}
- 3) Thickness of fixture t_{fix}

JCP Option 1 Throughbolt and Option 1 Throughbolt ITS

Installation parameters, Option 1 Throughbolt

Annex 5

Installation instructions, Option 1 Throughbolt

1		Drill hole perpendicular to concrete surface.
2		Blow out dust.
3		Drive in anchor.
4		Max. tightening torque T_{inst} shall be applied by using torque wrench.

Table 4: Standard thickness of concrete member and respective minimum spacing and edge distance, Option 1 Throughbolt

Anchor size			M8	M10	70 M12	M16	M20	M24	125 M24	M27
Steel zinc plated										
Minimum thickness of member	h_{std}	[mm]	100	120	140	170	200	230	-	250
Cracked concrete										
Minimum spacing	s_{min}	[mm]	40	45	60	60	95	100	-	125
	for $c \geq$	[mm]	70	70	100	100	150	180	-	300
Minimum edge distance	c_{min}	[mm]	40	45	60	60	95	100	-	180
	for $s \geq$	[mm]	80	90	140	180	200	220	-	540
Non-cracked concrete										
Minimum spacing	s_{min}	[mm]	40	45	60	65	90	100	-	125
	for $c \geq$	[mm]	80	70	120	120	180	180	-	300
Minimum edge distance	c_{min}	[mm]	50	50	75	80	130	100	-	180
	for $s \geq$	[mm]	100	100	150	150	240	220	-	540
Stainless steel A4, HCR										
Minimum thickness of member	h_{std}	[mm]	100	120	140	160	200	200	250	-
Cracked concrete										
Minimum spacing	s_{min}	[mm]	40	50	60	60	95	180	125	-
	für $c \geq$	[mm]	70	75	100	100	150	180	125	-
Minimum edge distance	c_{min}	[mm]	40	55	60	60	95	180	125	-
	für $s \geq$	[mm]	80	90	140	180	200	180	125	-
Non-cracked concrete										
Minimum spacing	s_{min}	[mm]	40	50	60	65	90	180	125	-
	für $c \geq$	[mm]	80	75	120	120	180	180	125	-
Minimum edge distance	c_{min}	[mm]	50	60	75	80	130	180	125	-
	für $s \geq$	[mm]	100	120	150	150	240	180	125	-

Intermediate values by linear interpolation.

Table 5: Minimum thickness of concrete of member and respective minimum spacing and edge distance, Option 1 Throughbolt

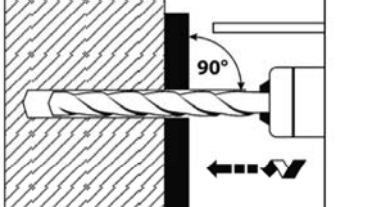
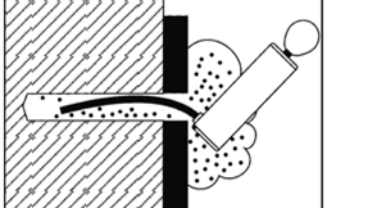
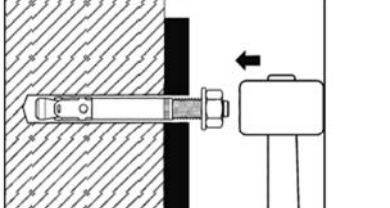
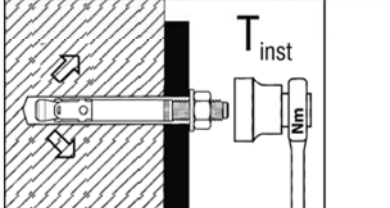
Anchor size			M8	M10	70 M12	M16	M20	M24	125 M24	M27
Steel zinc plated and Stainless steel A4, HCR										
Minimum thickness of member	h_{min}	[mm]	80	100	120	140	-	-	-	-
Cracked concrete										
Minimum spacing	s_{min}	[mm]	40	45	60	70	-	-	-	-
	for $c \geq$	[mm]	70	90	100	160	-	-	-	-
Minimum edge distance	c_{min}	[mm]	40	50	60	80	-	-	-	-
	for $s \geq$	[mm]	80	115	140	180	-	-	-	-
Non-cracked concrete										
Minimum spacing	s_{min}	[mm]	40	60	60	80	-	-	-	-
	für $c \geq$	[mm]	80	140	120	180	-	-	-	-
Minimum edge distance	c_{min}	[mm]	50	90	75	90	-	-	-	-
	für $s \geq$	[mm]	100	140	150	200	-	-	-	-

Intermediate values by linear interpolation.

JCP Option 1 Throughbolt and Option 1 Throughbolt ITS

**Minimum thickness of member,
Minimum spacing and edge distance,
Option 1 Throughbolt**

Annex 7

**Table 6: Characteristic values for tension loads, ETAG 001, Annex C, Option 1
Throughbolt, steel zinc plated**

Anchor size		M8	M10	70 M12	M16	M20	M24	M27	
Steel failure									
Characteristic resistance	$N_{Rk,s}$ [kN]	16	27	40	60	86	126	196	
Partial safety factor	γ_{Ms} [-]	1,53		1,5		1,6	1,5		
Pullout									
Characteristic resistance in cracked concrete C20/25	$N_{Rk,p}$ [kN]	5	9	16	25	³⁾	³⁾	³⁾	
Characteristic resistance in non-cracked concrete C20/25	$N_{Rk,p}$ [kN]	12	16	25	35	³⁾	³⁾	³⁾	
Splitting for standard thickness of concrete member (The higher resistance of Case 1 and Case 2 may be applied.)									
Standard thickness of concrete	$h_{std} \geq$ [mm]	100	120	140	170	200	230	250	
Case 1									
Characteristic resistance in concrete C20/25	$N^0_{Rk,sp}$ [kN]	9 ¹⁾	12 ¹⁾	20 ¹⁾	30 ¹⁾	40 ¹⁾	³⁾	50 ¹⁾	
Respective spacing	$s_{cr,sp}$ [mm]	3 h_{ef}							
Respective edge distance	$c_{cr,sp}$ [mm]	1,5 h_{ef}							
Case 2									
Characteristic resistance in concrete C20/25	$N^0_{Rk,sp}$ [kN]	12 ¹⁾	16 ¹⁾	25 ¹⁾	35 ¹⁾	³⁾	³⁾	³⁾	
Respective spacing	$s_{cr,sp}$ ²⁾ [mm]	4 h_{ef}				4,4 h_{ef}	3 h_{ef}	5 h_{ef}	
Respective edge distance	$c_{cr,sp}$ ²⁾ [mm]	2 h_{ef}				2,2 h_{ef}	1,5 h_{ef}	2,5 h_{ef}	
Splitting for minimum thickness of concrete member									
Minimum thickness of concrete	$h_{min} \geq$ [mm]	80	100	120	140	-	-	-	
Characteristic resistance in concrete C20/25	$N^0_{Rk,sp}$ [kN]	12 ¹⁾	16 ¹⁾	25 ¹⁾	35 ¹⁾	-	-	-	
Respective spacing	$s_{cr,sp}$ ²⁾ [mm]	5 h_{ef}					-	-	-
Respective edge distance	$c_{cr,sp}$ ²⁾ [mm]	2,5 h_{ef}					-	-	-
Increasing factors for $N_{Rk,p}$ and $N^0_{Rk,sp}$	ψ_C C30/37 [-]	1,22							
	C40/50 [-]	1,41							
	C50/60 [-]	1,55							
Concrete cone failure									
Effective anchorage depth	h_{ef} [mm]	46	60	70	85	100	115	125	
Spacing	$s_{cr,N}$ [mm]	3 h_{ef}							
Edge distance	$c_{cr,N}$ [mm]	1,5 h_{ef}							
Partial safety factor	$\gamma_{Mp} = \gamma_{Msp} = \gamma_{Mc}$ [-]	1,5							

¹⁾ For the proof against splitting failure according to ETAG 001, Annex C, $N^0_{Rk,c}$ in equation (5.3) has to be replaced by $N^0_{Rk,sp}$ with consideration of the member thickness ($\psi_{ucr,N} = 1,0$).

²⁾ The values $s_{cr,sp}$ and $c_{cr,sp}$ may be linearly interpolated for the member thickness $h_{min} < h < h_{std}$ (Case 2) ($\psi_{h,sp} = 1,0$).

³⁾ Pullout is not decisive

JCP Option 1 Throughbolt and Option 1 Throughbolt ITS

**Characteristic values for tension loads, ETAG 001, Annex C,
Option 1 Throughbolt, steel zinc plated**

Annex 8

**Table 7: Characteristic values for tension loads, ETAG 001, Annex C, Option 1
Throughbolt, stainless steel A4, HCR**

Anchor size		M8	M10	70 M12	M16	M20	M24	125 M24
Steel failure								
Characteristic resistance	$N_{Rk,s}$ [kN]	16	27	40	64	108	110	
Partial safety factor	γ_{Ms} [-]	1,5				1,68	1,5	
Pullout								
Characteristic resistance in cracked concrete C20/25	$N_{Rk,p}$ [kN]	5	9	16	25	³⁾	³⁾	40
Characteristic resistance in non-cracked concrete C20/25	$N_{Rk,p}$ [kN]	12	16	25	35	³⁾	³⁾	³⁾
Splitting for standard thickness of concrete member (The higher resistance of Case 1 and Case 2 may be applied.)								
Standard thickness of concrete	$h_{std} \geq$ [mm]	100	120	140	160	200	200	250
Case 1								
Characteristic resistance in concrete C20/25	$N^0_{Rk,sp}$ [kN]	9 ¹⁾	12 ¹⁾	20 ¹⁾	30 ¹⁾	40 ¹⁾	-	-
Respective spacing	$s_{cr,sp}$ [mm]	3 h_{ef}				-	-	-
Respective edge distance	$c_{cr,sp}$ [mm]	1,5 h_{ef}				-	-	-
Case 2								
Characteristic resistance in concrete C20/25	$N^0_{Rk,sp}$ [kN]	12 ¹⁾	16 ¹⁾	25 ¹⁾	35 ¹⁾	³⁾	³⁾	³⁾
Respective spacing	$s_{cr,sp}$ ²⁾ [mm]	230	250	280	400	440	600	500
Respective edge distance	$c_{cr,sp}$ ²⁾ [mm]	115	125	140	200	220	300	250
Splitting for minimum thickness of concrete member								
Minimum thickness of concrete	$h_{min} \geq$ [mm]	80	100	120	140	-	-	-
Characteristic resistance in concrete C20/25	$N^0_{Rk,sp}$ [kN]	12 ¹⁾	16 ¹⁾	25 ¹⁾	35 ¹⁾	-	-	-
Respective spacing	$s_{cr,sp}$ ²⁾ [mm]	5 h_{ef}				-	-	-
Respective edge distance	$c_{cr,sp}$ ²⁾ [mm]	2,5 h_{ef}				-	-	-
Increasing factors for $N_{Rk,p}$ and $N^0_{Rk,sp}$	ψ_C C30/37 [-]					1,22		
	C40/50 [-]					1,41		
	C50/60 [-]					1,55		
Concrete cone failure								
Effective anchorage depth	h_{ef} [mm]	46	60	70	85	100	100	125
Spacing	$s_{cr,N}$ [mm]	3 h_{ef}				-	-	-
Edge distance	$c_{cr,N}$ [mm]	1,5 h_{ef}				-	-	-
Partial safety factor	$\gamma_{Mp} = \gamma_{Msp} = \gamma_{Mc}$ [-]					1,5		

¹⁾ For the proof against splitting failure according to ETAG 001, Annex C, $N^0_{Rk,c}$ in equation (5.3) has to be replaced by $N^0_{Rk,sp}$ with consideration of the member thickness ($\psi_{ucr,N} = 1,0$).

²⁾ The values $s_{cr,sp}$ and $c_{cr,sp}$ may be linearly interpolated for the member thickness $h_{min} < h < h_{std}$ (Case 2) ($\psi_{h,sp} = 1,0$).

³⁾ Pullout is not decisive

JCP Option 1 Throughbolt and Option 1 Throughbolt ITS

**Characteristic values for tension loads, ETAG 001, Annex C,
Option 1 Throughbolt, stainless steel A4, HCR**

Annex 9

Table 8: Displacements under tension loads, Option 1 Throughbolt

Anchor size			M8	M10	70 M12	M16	M20	M24	125 M24	M27
Steel zinc plated										
Tension load in cracked concrete	N	[kN]	2,4	4,3	7,6	11,9	17,1	21,1	-	24
Displacement	δ_{N0}	[mm]	0,6	1,0	0,4	1,0	0,9	0,7	-	0,9
	$\delta_{N\infty}$	[mm]	1,4	1,2	1,4	1,3	1,0	1,2	-	1,4
Tension load in non-cracked concrete	N	[kN]	5,7	7,6	11,9	16,7	23,8	29,6	-	34
Displacement	δ_{N0}	[mm]	0,4	0,5	0,7	0,3	0,4	0,5	-	0,3
	$\delta_{N\infty}$	[mm]	0,8		1,4	0,8		-	1,4	
Stainless steel A4, HCR										
Tension load in cracked concrete	N	[kN]	2,4	4,3	7,6	11,9	17,1	17,0	19,0	-
Displacement	δ_{N0}	[mm]	0,7	1,8	0,4	0,7	0,9	0,5	0,5	-
	$\delta_{N\infty}$	[mm]	1,2	1,4	1,4	1,4	1,0	1,6	1,8	-
Tension load in non-cracked concrete	N	[kN]	5,8	7,6	11,9	16,7	23,8	24,1	33,5	-
Displacement	δ_{N0}	[mm]	0,6	0,5	0,7	0,2	0,4	1,5	0,5	-
	$\delta_{N\infty}$	[mm]	1,2	1,0	1,4	0,4	0,8	1,1	1,1	-

JCP Option 1 Throughbolt and Option 1 Throughbolt ITS

Displacements under tension loads, Option 1 Throughbolt

Annex 10

Table 9: Characteristic values for shear loads, ETAG 001, Annex C, Option 1 Throughbolt

Anchor size			M8	M10	70 M12	M16	M20	M24	125 M24	M27	
Steel failure without lever arm, Steel zinc plated											
Characteristic resistance	$V_{Rk,s}$	[kN]	15	22	30	60	69	114	-	169,4	
Partial safety factor	γ_{Ms}	[-]	1,25				1,33	1,25	-	1,25	
Steel failure without lever arm, Stainless steel A4, HCR											
Characteristic resistance	$V_{Rk,s}$	[kN]	13	20	30	55	86	123,6	-	-	
Partial safety factor	γ_{Ms}	[-]	1,25				1,4	1,25	-	-	
Steel failure with lever arm, Steel zinc plated											
Characteristic bending resistance	$M^0_{Rk,s}$	[Nm]	23	47	82	209	363	898	-	1331,5	
Partial safety factor	γ_{Ms}	[-]	1,25				1,33	1,25	-	1,25	
Steel failure with lever arm, Stainless steel A4, HCR											
Characteristic bending resistance	$M^0_{Rk,s}$	[Nm]	26	52	92	233	454	785,4	-	-	
Partial safety factor	γ_{Ms}	[-]	1,25				1,4	1,25	-	-	
Concrete pryout failure											
Factor in equation (5.6) ETAG 001, Annex C, 5.2.3.3	k	[-]					2,0				
Partial safety factor	γ_{Mcp}	[-]					1,5				
Concrete edge failure											
Effective length of anchor in shear loading	Steel zinc plated	l_f	[mm]	46	60	70	85	100	115	-	125
	Stainless steel A4, HCR	l_f	[mm]	46	60	70	85	100	100	125	-
Outside diameter of anchor	d_{nom}	[mm]	8	10	12	16	20	24		27	
Partial safety factor	γ_{Mc}	[-]					1,5				

Table 10: Displacements under shear loads, Option 1 Throughbolt

Anchor size			M8	M10	70 M12	M16	M20	M24	125 M24	M27
Steel zinc plated										
Shear load in cracked and non-cracked concrete	V	[kN]	8,6	12,6	17,1	34,3	36,8	64,9	-	96,8
Displacement	δ_{V0}	[mm]	2,3	2,2	2,2	4,0	1,8	3,5	-	3,6
	$\delta_{V\infty}$	[mm]	3,5	3,3	3,4	6,0	2,7	5,3	-	5,4
Stainless steel A4, HCR										
Shear load in cracked and non-cracked concrete	V	[kN]	7,3	11,6	16,9	31,3	43,8	70,6		-
Displacement	δ_{V0}	[mm]	3,2	4,4	5,2	6,5	2,9	2,8		-
	$\delta_{V\infty}$	[mm]	4,8	6,6	7,8	9,8	4,3	4,2		-

JCP Option 1 Throughbolt and Option 1 Throughbolt ITS

**Characteristic values for shear loads,
ETAG 001, Annex C,
Displacements under shear loads, Option 1 Throughbolt**

Annex 11

Table 11: Characteristic values of tension resistance under fire exposure in cracked and non-cracked concrete C20/25 to C 50/60, ETAG001, Annex C, Option 1 Throughbolt

Anchor size	M8			M10			70 M12			M16			M20			M24/125 M24 A4			M27																	
	30	60	90	120	30	60	90	120	30	60	90	120	30	60	90	120	30	60	90	120																
Fire resistance R... duration [min]	30	60	90	120	30	60	90	120	30	60	90	120	30	60	90	120	30	60	90	120																
Steel failure																																				
Characteristic resistance $N_{Rk,s,fi}$ [kN]	1,4	1,1	0,8	0,7	2,2	1,8	1,4	1,2	3,2	2,8	2,4	2,2	6,0	5,2	4,4	4,0	9,4	8,2	6,9	6,3	13,6	11,8	10,0	9,1	17,6	15,3	13,0	11,8								
vz. A4 / HCR	3,8	2,9	2,0	1,6	6,9	5,2	3,5	2,7	11,5	8,6	5,6	4,2	21,5	16,0	10,5	7,8	33,5	25,0	16,4	12,1	48,2	35,9	23,6	17,4	-	-	-	-								
Pullout failure																																				
Characteristic resistance in concrete $N_{Rk,p,fi}$ C20/25 to C50/60 [kN]	1,3			1,0			2,3			1,8			4,0			3,2			6,3			5,0			7,2			11,0			8,8			10,1		
vz. A4 / HCR																																				
Concrete cone failure																																				
Characteristic resistance in concrete $N^0_{Rk,c,fi}$ C20/25 to C50/60 [kN]	2,6			2,1			5,0			4,0			7,4			5,9			12,0			9,6			14,4			25,5			20,4			25,2		
vz. A4 / HCR																																				
Spacing $S_{cr,N,fi}$	4 X h_{ef}																																			
Edge distance $C_{cr,N,fi}$	2 X h_{ef}																																			
Minimum spacing and edge distance under fire exposure from one side	According to Annex 7																																			
Minimum spacing and edge distance under fire exposure from more than one side	S_{min} according to Annex 7; $C_{min} \geq 300$ mm																																			

In absence of other national regulations the partials safety factor for resistance under fire exposure $\gamma_{M,fi} = 1,0$ recommended.

¹⁾ only 125 M24 A4

JCP Option 1 Throughbolt and Option 1 Throughbolt ITS

Characteristic values of tension resistance under fire exposure, ETAG001, Annex C, Option 1 Throughbolt

Annex 12

Table 12: Characteristic shear resistance under fire exposure in cracked and non-cracked concrete C20/25 to C50/60, ETAG001, Annex C, Option 1 Throughbolt

Anchor size	M8			M10			70 M12			M16			M20			M24 / 125 M24 A4			M27								
	30	60	90	120	30	60	90	120	30	60	90	120	30	60	90	120	30	60	90	120	30	60	90				
Fire resistance duration R... [min]	30	60	90	120	30	60	90	120	30	60	90	120	30	60	90	120	30	60	90	120	30	60	90	120			
Steel failure without lever arm																											
Characteristic resistance $V_{Rk,s,fi}$ [kN]	vz.																										
	1,6	1,5	1,2	1,0	2,6	2,5	2,1	2,0	3,8	3,6	3,5	3,4	7,0	6,8	6,5	6,4	11,0	11,0	10,0	10,0	16,0	15,0	14,0	20,6	19,8	19,0	18,6
A4/ HCR	3,8																										
	2,9	2,0	1,6	6,9	5,2	3,5	2,7	11,5	8,6	5,6	4,2	21,5	16,0	10,5	7,8	33,5	25,0	16,4	12,1	48,2	35,9	23,6	17,4	-	-	-	
Steel failure with lever arm																											
Characteristic resistance $M^0_{Rk,s,fi}$ [Nm]	vz.																										
	1,7	1,6	1,2	1,1	3,3	3,2	2,7	2,5	5,9	5,6	5,4	5,3	15,0	14,0	14,0	13,0	29,0	28,0	27,0	26,0	50,0	48,0	47,0	46,0	75,0	72,0	69,0
A4/ HCR	3,8																										
	2,9	2,1	1,6	9,0	6,8	4,5	3,4	17,9	13,3	8,8	6,5	45,5	33,9	22,2	16,4	88,8	66,1	43,4	32,1	153,5	114,3	75,1	55,5	-	-	-	-
concrete pryout failure:																											
In Equation (5.6) of ETAG 001, Annex C, 5.2.3.3 the k-factor 2,0 and the relevant values of $N^0_{Rk,c,fi}$ of Table 11 have to be considered.																											
Concrete edge failure:																											
The initial value $V^0_{Rk,c,fi}$ of the characteristic resistance in concrete C20/25 to C50/60 under fire exposure may be determined by: $V^0_{Rk,c,fi} = 0,25 \times V^0_{Rk,c} \text{ (R30, R60, R90)} \quad V^0_{Rk,c,fi} = 0,20 \times V^0_{Rk,c} \text{ (R120)}$ with $V^0_{Rk,c}$ initial value of the characteristic resistance in cracked concrete C20/25 under normal temperature.																											
In absence of other national regulations the partial factor for resistance under fire exposure $\gamma_{M,fi} = 1,0$ recommended.																											

JCP Option 1 Throughbolt and Option 1 Throughbolt ITS

Characteristic shear resistance under fire exposure, ETAG 001, Annex C, Option 1 Throughbolt

Annex 13

**Table 13: Characteristic values for tension loads, CEN/TS 1992-4, Option 1
Throughbolt, steel zinc plated**

Anchor size		M8	M10	70 M12	M16	M20	M24	M27
Steel failure								
Characteristic resistance	$N_{Rk,s}$ [kN]	16	27	40	60	86	126	196
Partial safety factor	γ_{Ms} [-]	1,53		1,5		1,6	1,5	
Pullout								
Characteristic resistance in cracked concrete C20/25	$N_{Rk,p}$ [kN]	5	9	16	25	³⁾	³⁾	³⁾
Characteristic resistance in non-cracked concrete C20/25	$N_{Rk,p}$ [kN]	12	16	25	35	³⁾	³⁾	³⁾
Splitting for standard thickness of concrete member (The higher resistance of Case 1 and Case 2 may be applied.)								
Standard thickness of concrete	$h_{std} \geq$ [mm]	100	120	140	170	200	230	250
Case 1								
Characteristic resistance in concrete C20/25	$N^0_{Rk,sp}$ [kN]	9 ¹⁾	12 ¹⁾	20 ¹⁾	30 ¹⁾	40 ¹⁾	³⁾	50 ¹⁾
Respective spacing	$s_{cr,sp}$ [mm]	3 h_{ef}						
Respective edge distance	$c_{cr,sp}$ [mm]	1,5 h_{ef}						
Case 2								
Characteristic resistance in concrete C20/25	$N^0_{Rk,sp}$ [kN]	12 ¹⁾	16 ¹⁾	25 ¹⁾	35 ¹⁾	³⁾	³⁾	³⁾
Respective spacing	$s_{cr,sp}$ ²⁾ [mm]	4 h_{ef}				4,4 h_{ef}	3 h_{ef}	5 h_{ef}
Respective edge distance	$c_{cr,sp}$ ²⁾ [mm]	2 h_{ef}				2,2 h_{ef}	1,5 h_{ef}	2,5 h_{ef}
Splitting for minimum thickness of concrete member								
Minimum thickness of concrete	$h_{min} \geq$ [mm]	80	100	120	140	-	-	-
Characteristic resistance in concrete C20/25	$N^0_{Rk,sp}$ [kN]	12 ¹⁾	16 ¹⁾	25 ¹⁾	35 ¹⁾	-	-	-
Respective spacing	$s_{cr,sp}$ ²⁾ [mm]	5 h_{ef}				-	-	-
Respective edge distance	$c_{cr,sp}$ ²⁾ [mm]	2,5 h_{ef}				-	-	-
Increasing factors for $N_{Rk,p}$ and $N^0_{Rk,sp}$	ψ_C C30/37 [-]	1,22						
	C40/50 [-]	1,41						
	C50/60 [-]	1,55						
Concrete cone failure								
Effective anchorage depth	h_{ef} [mm]	46	60	70	85	100	115	125
Spacing	$s_{cr,N}$ [mm]	3 h_{ef}						
Edge distance	$c_{cr,N}$ [mm]	1,5 h_{ef}						
Partial safety factor	$\gamma_{Mp} = \gamma_{Msp} = \gamma_{Mc}$ [-]	1,5						

¹⁾ For the proof against splitting failure according to CEN/TS 1992-4-4, $N^0_{Rk,e}$ in equation (12) has to be replaced by $N^0_{Rk,sp}$ with consideration of the member thickness ($\psi_{ucr,N} = 1,0$).

²⁾ The values $s_{cr,sp}$ and $c_{cr,sp}$ may be linearly interpolated for the member thickness $h_{min} < h < h_{std}$ (Case 2) ($\psi_{h,sp} = 1,0$).

³⁾ Pullout is not decisive

JCP Option 1 Throughbolt and Option 1 Throughbolt ITS

**Characteristic values for tension loads, CEN/TS 1992-4, Option 1
Throughbolt, steel zinc plated**

Annex 14

**Table 14: Characteristic values for tension loads, CEN/TS 1992-4, Option 1
Throughbolt, stainless steel A4, HCR**

Anchor size		M8	M10	70 M12	M16	M20	M24	125 M24
Steel failure								
Characteristic resistance	$N_{Rk,s}$ [kN]	16	27	40	64	108	110	
Partial safety factor	γ_{Ms} [-]	1,5				1,68	1,5	
Pullout								
Characteristic resistance in cracked concrete C20/25	$N_{Rk,p}$ [kN]	5	9	16	25	3)	3)	40
Characteristic resistance in non-cracked concrete C20/25	$N_{Rk,p}$ [kN]	12	16	25	35	3)	3)	3)
Splitting for standard thickness of concrete member (The higher resistance of Case 1 and Case 2 may be applied.)								
Standard thickness of concrete	$h_{std} \geq$ [mm]	100	120	140	160	200	200	250
Case 1								
Characteristic resistance in concrete C20/25	$N^0_{Rk,sp}$ [kN]	9 ¹⁾	12 ¹⁾	20 ¹⁾	30 ¹⁾	40 ¹⁾	-	-
Respective spacing	$s_{cr,sp}$ [mm]	3 h_{ef}				-	-	-
Respective edge distance	$c_{cr,sp}$ [mm]	1,5 h_{ef}				-	-	-
Case 2								
Characteristic resistance in concrete C20/25	$N^0_{Rk,sp}$ [kN]	12 ¹⁾	16 ¹⁾	25 ¹⁾	35 ¹⁾	3)	3)	3)
Respective spacing	$s_{cr,sp}$ ²⁾ [mm]	230	250	280	400	440	600	500
Respective edge distance	$c_{cr,sp}$ ²⁾ [mm]	115	125	140	200	220	300	250
Splitting for minimum thickness of concrete member								
Minimum thickness of concrete	$h_{min} \geq$ [mm]	80	100	120	140	-	-	-
Characteristic resistance in concrete C20/25	$N^0_{Rk,sp}$ [kN]	12 ¹⁾	16 ¹⁾	25 ¹⁾	35 ¹⁾	-	-	-
Respective spacing	$s_{cr,sp}$ ²⁾ [mm]	5 h_{ef}				-	-	-
Respective edge distance	$c_{cr,sp}$ ²⁾ [mm]	2,5 h_{ef}				-	-	-
Increasing factors for $N_{Rk,p}$ and $N^0_{Rk,sp}$	ψ_C C30/37 [-]					1,22		
	C40/50 [-]					1,41		
	C50/60 [-]					1,55		
Concrete cone failure								
Effective anchorage depth	h_{ef} [mm]	46	60	70	85	100	100	125
Spacing	$s_{cr,N}$ [mm]					3 h_{ef}		
Edge distance	$c_{cr,N}$ [mm]					1,5 h_{ef}		
Partial safety factor	$\gamma_{Mp} = \gamma_{Msp} = \gamma_{Mc}$ [-]					1,5		

¹⁾ For the proof against splitting failure according to CEN/TS 1992-4-4, $N^0_{Rk,c}$ in equation (12) has to be replaced by $N^0_{Rk,sp}$ with consideration of the member thickness ($\psi_{ucr,N} = 1,0$).

²⁾ The values $s_{cr,sp}$ and $c_{cr,sp}$ may be linearly interpolated for the member thickness $h_{min} < h < h_{std}$ (Case 2) ($\psi_{h,sp} = 1,0$).

³⁾ Pullout is not decisive

JCP Option 1 Throughbolt and Option 1 Throughbolt ITS

**Characteristic values for tension loads, CEN/TS 1992-4, Option 1
Throughbolt, stainless steel A4, HCR**

Annex 15

Table 15: Displacements under tension loads, Option 1 Throughbolt

Anchor size			M8	M10	70 M12	M16	M20	M24	125 M24	M27
Steel zinc plated										
Tension load in cracked concrete	N	[kN]	2,4	4,3	7,6	11,9	17,1	21,1	-	24
Displacement	δ_{N0}	[mm]	0,6	1,0	0,4	1,0	0,9	0,7	-	0,9
	$\delta_{N\infty}$	[mm]	1,4	1,2	1,4	1,3	1,0	1,2	-	1,4
Tension load in non-cracked concrete	N	[kN]	5,7	7,6	11,9	16,7	23,8	29,6	-	34
Displacement	δ_{N0}	[mm]	0,4	0,5	0,7	0,3	0,4	0,5	-	0,3
	$\delta_{N\infty}$	[mm]	0,8		1,4	0,8		-	1,4	
Stainless steel A4, HCR										
Tension load in cracked concrete	N	[kN]	2,4	4,3	7,6	11,9	17,1	17,0	19,0	-
Displacement	δ_{N0}	[mm]	0,7	1,8	0,4	0,7	0,9	0,5	0,5	-
	$\delta_{N\infty}$	[mm]	1,2	1,4	1,4	1,4	1,0	1,6	1,8	-
Tension load in non-cracked concrete	N	[kN]	5,8	7,6	11,9	16,7	23,8	24,1	33,5	-
Displacement	δ_{N0}	[mm]	0,6	0,5	0,7	0,2	0,4	1,5	0,5	-
	$\delta_{N\infty}$	[mm]	1,2	1,0	1,4	0,4	0,8	1,1	1,1	-

JCP Option 1 Throughbolt and Option 1 Throughbolt ITS

Displacements under tension loads, Option 1 Throughbolt

Annex 16

Table 16: Characteristic values for shear loads, CEN/TS 1992-4, Option 1 Throughbolt

Anchor size			M8	M10	70 M12	M16	M20	M24	125 M24	M27	
Steel failure without lever arm, Steel zinc plated											
Characteristic resistance	$V_{Rk,s}$	[kN]	15	22	30	60	69	114	-	169,4	
Factor of ductility	k_2	[-]	1,0						-	1,0	
Partial safety factor	γ_{Ms}	[-]	1,25				1,33	1,25	-	1,25	
Steel failure without lever arm, Stainless steel A4, HCR											
Characteristic resistance	$V_{Rk,s}$	[kN]	13	20	30	55	86	123,6	-	-	
Factor of ductility	k_2	[-]	1,0						-	-	
Partial safety factor	γ_{Ms}	[-]	1,25				1,4	1,25	-	-	
Steel failure with lever arm, Steel zinc plated											
Characteristic bending resistance	$M_{Rk,s}^0$	[Nm]	23	47	82	209	363	898	-	1331,5	
Partial safety factor	γ_{Ms}	[-]	1,25				1,33	1,25	-	1,25	
Steel failure with lever arm, Stainless steel A4, HCR											
Characteristic bending resistance	$M_{Rk,s}^0$	[Nm]	26	52	92	233	454	785,4	-	-	
Partial safety factor	γ_{Ms}	[-]	1,25				1,4	1,25	-	-	
Concrete pryout failure											
Factor in equation (16) CEN/TS 1992-4-4, 6.2.2.3	k_3	[-]	2,0						-	-	
Partial safety factor	γ_{Mcp}	[-]	1,5						-	-	
Concrete edge failure											
Effective length of anchor in shear loading	Steel zinc plated	l_f	[mm]	46	60	70	85	100	115	-	125
	Stainless steel A4, HCR	l_f	[mm]	46	60	70	85	100	100	125	-
Outside diameter of anchor	d_{nom}	[mm]	8	10	12	16	20	24	24	27	
Partial safety factor	γ_{Mc}	[-]	1,5						-	-	

Table 17: Displacements under shear loads, Option 1 Throughbolt

Anchor size			M8	M10	70 M12	M16	M20	M24	125 M24	M27
Steel zinc plated										
Shear load in cracked and non-cracked concrete	V	[kN]	8,6	12,6	17,1	34,3	36,8	64,9	-	96,8
Displacement	δ_{V0}	[mm]	2,3	2,2	2,2	4,0	1,8	3,5	-	3,6
	$\delta_{V\infty}$	[mm]	3,5	3,3	3,4	6,0	2,7	5,3	-	5,4
Stainless steel A4, HCR										
Shear load in cracked and non-cracked concrete	V	[kN]	7,3	11,6	16,9	31,3	43,8	70,6	-	-
Displacement	δ_{V0}	[mm]	3,2	4,4	5,2	6,5	2,9	2,8	-	-
	$\delta_{V\infty}$	[mm]	4,8	6,6	7,8	9,8	4,3	4,2	-	-

JCP Option 1 Throughbolt and Option 1 Throughbolt ITS

**Characteristic values for shear loads,
CEN/TS 1992-4,
Displacements under shear loads, Option 1 Throughbolt**

Annex 17

Table 18: Characteristic values of tension resistance under fire exposure in cracked and non-cracked concrete C20/25 to C50/60, CEN/TS 1992-4, Option 1 Throughbolt

Anchor size	M8			M10			70 M12			M16			M20			M24/125 M24 A4			M27											
	30	60	90	120	30	60	90	120	30	60	90	120	30	60	90	120	30	60	90	120	30	60	90	120						
Fire resistance duration [min]	30	60	90	120	30	60	90	120	30	60	90	120	30	60	90	120	30	60	90	120	30	60	90	120	30	60	90	120		
Steel failure																														
Characteristic resistance $N_{Rk,s,fi}$ [kN]	1,4			1,1	0,8	0,7	2,2	1,8	1,4	1,2	3,2	2,8	2,4	2,2	6,0	5,2	4,4	4,0	9,4	8,2	6,9	6,3	13,6	11,8	10,0	9,1	17,6	15,3	13,0	11,8
	vz.																													
	A4 / HCR																													
Characteristic resistance $N_{Rk,p,fi}$ [kN]	3,8			2,9	2,0	1,6	6,9	5,2	3,5	2,7	11,5	8,6	5,6	4,2	21,5	16,0	10,5	7,8	33,5	25,0	16,4	12,1	48,2	35,9	23,6	17,4	-	-	-	
	vz.																													
	A4 / HCR																													
Pullout failure																														
Characteristic resistance in concrete C20/25 to C50/60	1,3			1,0	2,3	1,8	4,0	3,2	6,3	5,0	9,0	7,2	11,0	8,8	9,0 / 12,6 ¹⁾	7,2	10,1	12,6	10,1	12,6	10,1	12,6	10,1	12,6	10,1	12,6	10,1	12,6	10,1	
	vz.																													
	A4 / HCR																													
Concrete cone failure																														
Characteristic resistance in concrete C20/25 to C50/60	2,6			2,1	5,0	4,0	7,4	5,9	12,0	9,6	18,0	14,4	25,5	20,4	18,1 / 31,5 ¹⁾	14,4	25,2	31,5	25,2	31,5	25,2	31,5	25,2	31,5	25,2	31,5	25,2	31,5	25,2	
	vz.																													
	A4 / HCR																													
Spacing $s_{cr,N,fi}$	4 x hef																													
Edge distance $c_{cr,N,fi}$	2 x hef																													
Minimum spacing and edge distance under fire exposure from one side	According to Annex 7																													
Minimum spacing and edge distance under fire exposure from more than one side	s_{min} according to Annex 7; $c_{min} \geq 300$ mm																													
Partial safety factor $\gamma_{M,fi}$ [-]	1,0																													

¹⁾ Only 125 M24 A4

JCP Option 1 Throughbolt and Option 1 Throughbolt ITS

Characteristic values of tension resistance under fire exposure, CEN/TS 1992-4, Option 1 Throughbolt

Annex 18

Table 19: Characteristic shear resistance under fire exposure in cracked and non-cracked concrete C20/25 to C50/60, CEN/TS 1992-4, Option 1 Throughbolt

Anchor size	M8		M10		70 M12		M16		M20		M24 / 125 M24 A4		M27																																											
	30	60	90	120	30	60	90	120	30	60	90	120	30	60	90	120																																								
Fire resistance R... duration [min]	30	60	90	120	30	60	90	120	30	60	90	120	30	60	90	120																																								
Steel failure without lever arm																																																								
Characteristic resistance $V_{Rk,s,fi}$ [kN]	1,6		1,5		1,2		1,0		2,6		2,5		2,1		2,0		3,8		3,6		3,5		3,4		7,0		6,8		6,5		6,4		11,0		11,0		10,0		10,0		16,0		15,0		14,0		20,6		19,8		19,0		18,6			
Characteristic resistance $M^0_{Rk,s,fi}$ [Nm]	3,8		2,9		2,0		1,6		6,9		5,2		3,5		2,7		11,5		8,6		5,6		4,2		21,5		16,0		10,5		7,8		33,5		25,0		16,4		12,1		48,2		35,9		23,6		17,4		-		-		-		-	
Steel failure with lever arm																																																								
Characteristic resistance $M^0_{Rk,s,fi}$ [Nm]	1,7		1,6		1,2		1,1		3,3		3,2		2,7		2,5		5,9		5,6		5,4		5,3		15,0		14,0		14,0		13,0		29,0		28,0		27,0		26,0		50,0		48,0		47,0		46,0		75,0		72,0		69,0		68,0	
concrete pryout failure:	3,8		2,9		2,1		1,6		9,0		6,8		4,5		3,4		17,9		13,		8,8		6,5		45,5		33,9		22,2		16,4		88,8		66,1		43,4		32,1		153,5		114,3		75,1		55,5		-		-		-			
Concrete edge failure:																																																								
The initial value $V^0_{Rk,c,fi}$ of the characteristic resistance in concrete C20/25 to C50/60 under fire exposure may be determined by: $V^0_{Rk,c,fi} = 0,25 \times V^0_{Rk,c}$ (R30, R60, R90) $V^0_{Rk,c,fi} = 0,20 \times V^0_{Rk,c}$ (R120)																																																								
with $V^0_{Rk,c}$ initial value of the characteristic resistance in cracked concrete C20/25 under normal temperature.																																																								
Partial safety factor $\gamma_{M,fi}$ [-]	1,0																																																							

JCP Option 1 Throughbolt and Option 1 Throughbolt ITS

Characteristic shear resistance under fire exposure, CEN/TS 1992-4, Option 1 Throughbolt

Annex 19

Intended use Option 1 Throughbolt ITS

Installation type V pre-setting installation

pre-set anchor body, the fixture bears on the screw or thread rod only

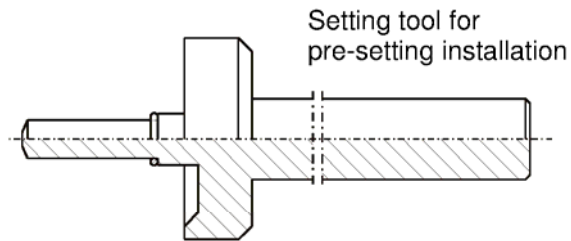

Option 1 Throughbolt ITS S consisting of BZ-IG and S-IG

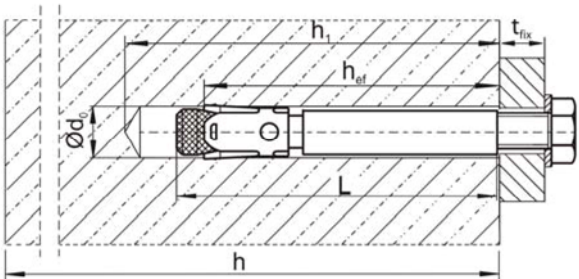

Option 1 Throughbolt ITS SK consisting of BZ-IG and SK-IG

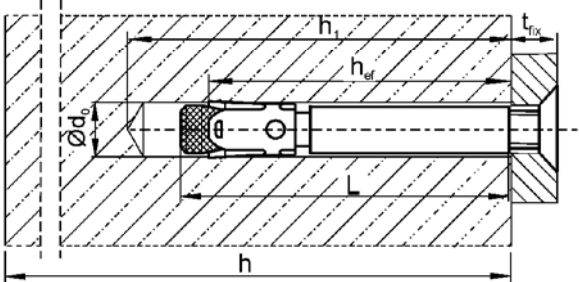

Option 1 Throughbolt ITS B consisting of BZ-IG and MU-IG

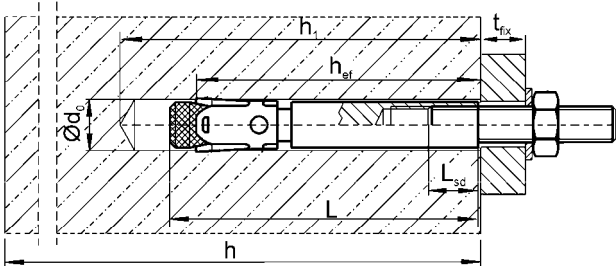

Installation type D through-setting installation

the anchor is set through the fixture, the fixture bears on the conical bolt Option 1 Throughbolt ITS

Setting tool for through-setting installation

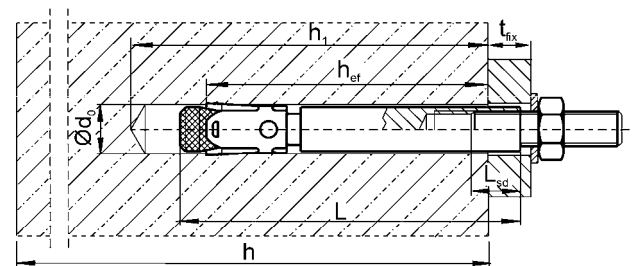
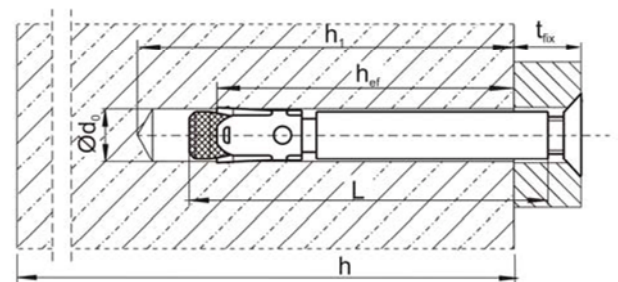
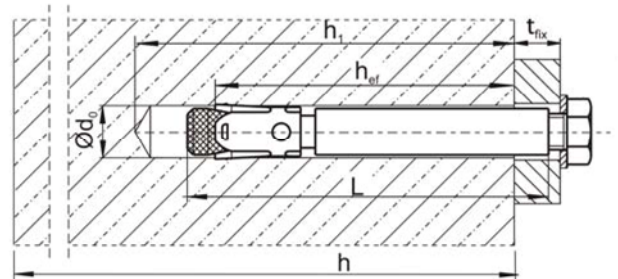
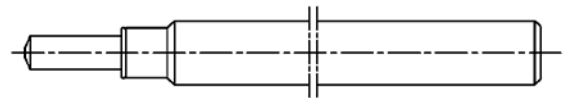

JCP Option 1 Throughbolt and Option 1 Throughbolt ITS

Intended use Option 1 Throughbolt ITS

Annex 20

Marking: \diamond Identifying mark of Manufacturing plant
 BZ Anchor identify
 M6 Size of thread
 10 max. thickness of fixture
 (only installation type D)
 A4 additionally for stainless steel
 HCR additionally for high corrosion resistant
 steel

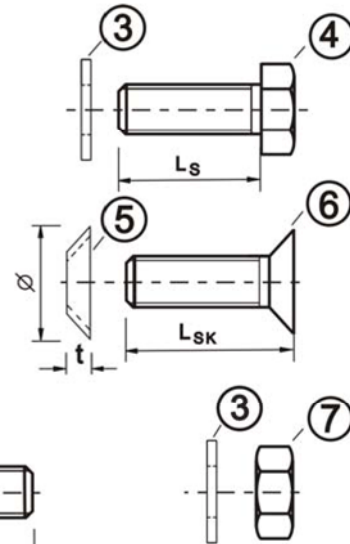
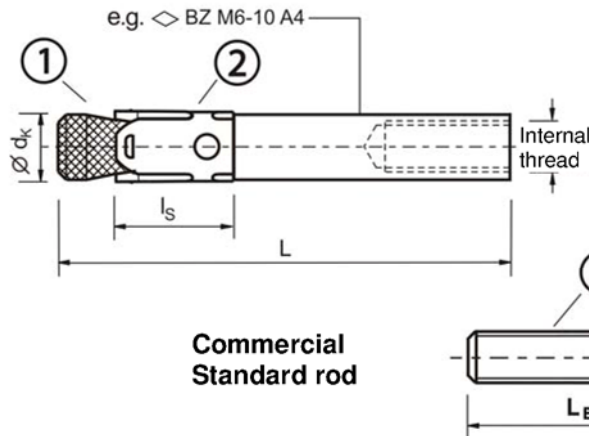

S-IG

SK-IG

MU-IG

Table 20: Anchor dimensions, Option 1 Throughbolt ITS

No.	Anchor size		M6	M8	M10	M12
1	Conical bolt with Internal thread Installation type V Installation type D	$\varnothing d_k$	7,9	9,8	11,8	15,7
		L	50	62	70	86
		L	$50 + t_{fix}$	$62 + t_{fix}$	$70 + t_{fix}$	$86 + t_{fix}$
2	Expansion sleeve	l_s	14,5	18,5	22,0	24,3
3	Washer		see table 21			
4	Hexagon head screw Installation type V Installation type D	width across flats	10	13	17	19
		L_s	$t_{fix} + (13 \text{ to } 21)$	$t_{fix} + (17 \text{ to } 23)$	$t_{fix} + (21 \text{ to } 25)$	$t_{fix} + (24 \text{ to } 29)$
		L_s	14 to 20	18 to 22	20 to 22	25 to 28
5	Countersunk washer	\varnothing countersink	17,3	21,5	25,9	30,9
		t	3,9	5,0	5,7	6,7
6	Countersunk head screw Installation type V Installation type D	bit size	Torx T30	Torx T45 (Steel, zinc plated) T40 (Stainless steel A4, HCR)	Hexagon socket 6 mm	Hexagon socket 8 mm
		L_{SK}	$t_{fix} + (11 \text{ to } 19)$	$t_{fix} + (15 \text{ to } 21)$	$t_{fix} + (19 \text{ to } 23)$	$t_{fix} + (21 \text{ to } 27)$
		L_{SK}	16 to 20	20 to 25	25	30
7	Hexagon nut	width across flats	10	13	17	19
8	Commercial Standard rod ¹⁾	type V $L_B \geq$	$t_{fix} + 21$	$t_{fix} + 28$	$t_{fix} + 34$	$t_{fix} + 41$
		type D $L_B \geq$	21	28	34	41

¹⁾ acc. to specifications (Table 21)

Dimensions in mm

JCP Option 1 Throughbolt and Option 1 Throughbolt ITS

Anchor dimensions, Option 1 Throughbolt ITS

Annex 21

Table 21: Materials, Option 1 Throughbolt ITS

No.	Part	Steel, zinc plated ≥ 5 µm acc. to EN ISO 4042	Stainless steel A4	High corrosion resistant steel HCR
1	Conical bolt Option 1 Throughbolt ITS With internal thread	Machined steel, Cone plastic coated	Stainless steel, 1.4401, 1.4404, 1.4571, 1.4362, EN 10088, Cone plastic coated	Stainless steel, 1.4529, 1.4565, EN 10088, Cone plastic coated
2	Expansion sleeve Option 1 Throughbolt ITS	Stainless steel, 1.4301, 1.4303, EN 10088	Stainless steel, 1.4401, 1.4571, EN 10088	Stainless steel, 1.4401, 1.4571, EN 10088
3	Washer S-IG / MU-IG acc. to DIN EN 7089 or DIN EN 7093 or DIN EN 7094	Steel, EN 10025-2	Stainless steel, 1.4401, 1.4571, EN 10088	Stainless steel, 1.4529, 1.4565, EN 10088
4	Hexagon head screw S-IG	Steel, Property class 8.8, EN ISO 898-1, coated	Stainless steel, 1.4401, 1.4571, EN 10088, Property class 70, EN ISO 3506, coated	Stainless steel, 1.4529, 1.4565, EN 10088, Property class 70, EN ISO 3506, coated
5	Countersunk washer SK-IG	Steel, EN 10083-2	Stainless steel, 1.4401, 1.4404, 1.4571, EN 10088, zinc plated, coated	Stainless steel, 1.4529, 1.4565, EN 10088, zinc plated, coated
6	Countersunk head screw SK-IG	Steel, Property class 8.8, acc. to EN ISO 898-1, coated	Stainless steel, 1.4401, 1.4571, EN 10088, Property class 70, EN ISO 3506, coated	Stainless steel, 1.4529, 1.4565, EN 10088, Property class 70, EN ISO 3506, coated
7	Hexagon nut MU-IG	Steel, Property class 8, acc. to EN ISO 898-2, coated	Stainless steel, 1.4401, 1.4571, EN 10088, Property class 70, EN ISO 3506, coated	Stainless steel, 1.4529, 1.4565, EN 10088, Property class 70, EN ISO 3506, coated
8	Commercial standard rod	Property class 8.8, acc. to EN ISO 898-1 A ₅ > 8 % ductile	Stainless steel, 1.4401, 1.4571, EN 10088, Property class 70, EN ISO 3506	Stainless steel, 1.4529, 1.4565, EN 10088, Property class 70, EN ISO 3506

JCP Option 1 Throughbolt and Option 1 Throughbolt ITS

Materials, Option 1 Throughbolt ITS

Annex 22

Table 22: Installation parameters, Option 1 Throughbolt ITS

Anchor size			M6	M8	M10	M12
Effective anchorage depth	h_{ef}	[mm]	45	58	65	80
Drill hole diameter	d_0	[mm]	8	10	12	16
Cutting diameter of drill bit	$d_{cut} \leq$	[mm]	8,45	10,45	12,5	16,5
Depth of drill hole	$h_1 \geq$	[mm]	60	75	90	105
Screwing depth of thread rod	$L_{sd}^{2)} \geq$	[mm]	9	12	15	18
Installation moment, zinc plated steel	T_{inst} S	[Nm]	10	30	30	55
	SK	[Nm]	10	25	40	50
	B	[Nm]	8	25	30	45
Installation moment, stainless steel A4 and high corrosion resistant steel HCR	T_{inst} S	[Nm]	15	40	50	100
	SK	[Nm]	12	25	45	60
	B	[Nm]	8	25	40	80
Installation type V						
Diameter of clearance hole in the fixture	$d_f \leq$	[mm]	7	9	12	14
Minimum thickness of fixture	$t_{fix} \geq$ S	[mm]	1	1	1	1
	SK	[mm]	5	7	8	9
	B	[mm]	1	1	1	1
Installation type D						
Diameter of clearance hole in the fixture	$d_f \leq$	[mm]	9	12	14	18
Minimum thickness of fixture ¹⁾	$t_{fix} \geq$ S	[mm]	5	7	8	9
	SK	[mm]	9	12	14	16
	B	[mm]	5	7	8	9

¹⁾ The minimum thickness of fixture can be reduced to the value of installation type V, if the shear load at steel failure is designed with lever arm according to equation (5.5) of ETAG 001, Annex C.

²⁾ see Annex 21



Setting check for Installation type V:

The anchor is placed correctly in the drill hole if the setting tool leaves a visible marking on the concrete surface.

Table 23: Minimum thickness of concrete member, minimum spacing and minimum edge distance, Option 1 Throughbolt ITS

Anchor size			M6	M8	M10	M12
Minimum thickness of concrete member	h_{min}	[mm]	100	120	130	160
Cracked concrete						
Minimum spacing	s_{min}	[mm]	50	60	70	80
	für $c \geq$	[mm]	60	80	100	120
Minimum edge distance	c_{min}	[mm]	50	60	70	80
	für $s \geq$	[mm]	75	100	100	120
Non-cracked concrete						
Minimum spacing	s_{min}	[mm]	50	60	65	80
	für $c \geq$	[mm]	80	100	120	160
Minimum edge distance	c_{min}	[mm]	50	60	70	100
	für $s \geq$	[mm]	115	155	170	210

JCP Option 1 Throughbolt and Option 1 Throughbolt ITS

**Installation parameters,
Minimum member thickness,
Minimum spacing and edge distance, Option 1 Throughbolt ITS**

Annex 23

Installation instructions pre-setting installation, Option 1 Throughbolt ITS

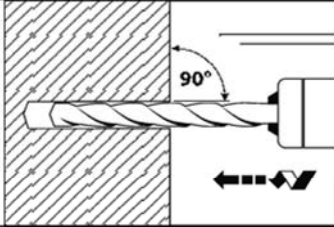
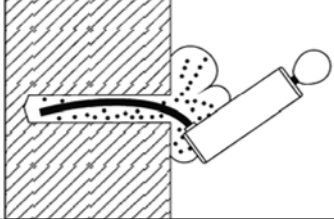
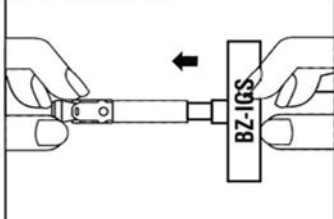
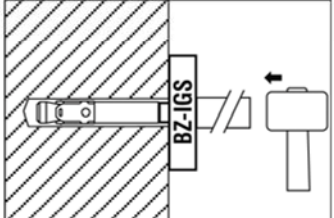
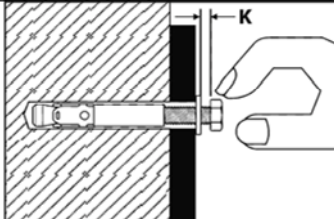
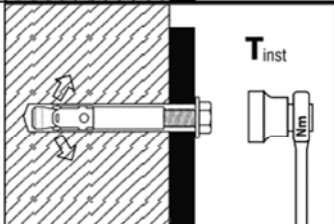
1		Drill hole perpendicular to concrete surface.
2		Blow out dust.
3		Setting tool insert in anchor.
4		Drive in anchor with setting tool.
5		Check screwing depth by the excess length (K) of the screw.
6		Max. tightening torque T_{inst} may be applied by using torque wrench.

JCP Option 1 Throughbolt and Option 1 Throughbolt ITS

Installation instructions, Option 1 Throughbolt ITS

Annex 24

Installation instructions through-setting installation, Option 1 Throughbolt ITS

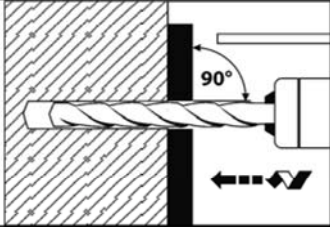
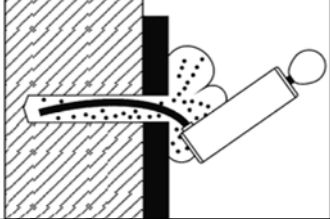
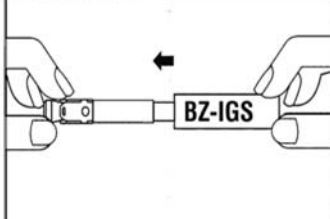
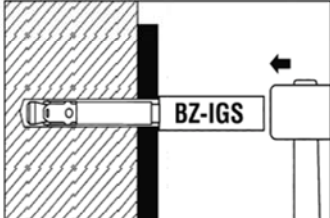
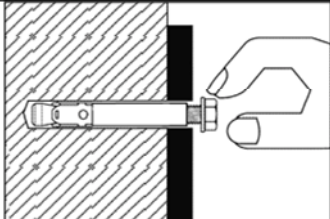
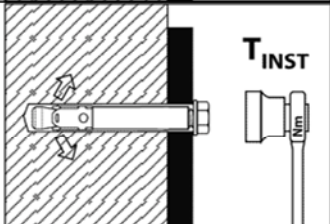
1		Drill hole perpendicular to concrete surface.
2		Blow out dust.
3		Setting tool insert in anchor.
4		Drive in anchor with setting tool.
5		Drive in screw.
6		Max. tightening torque T_{inst} may be applied by using torque wrench.

JCP Option 1 Throughbolt and Option 1 Throughbolt ITS

Installation instructions through-setting installation, Option 1 Throughbolt ITS

Annex 25

Table 24: Characteristic values for tension loads, ETAG 001, Annex C, Option 1 Throughbolt ITS

Anchor size			M6	M8	M10	M12
Steel failure						
Characteristic resistance, steel zinc plated	$N_{Rk,s}$	[kN]	16,1	22,6	26,0	56,6
Partial safety factor	γ_{Ms}	[-]	1,5			
Characteristic resistance, stainless steel A4 and high corrosion resistant steel HCR	$N_{Rk,s}$	[kN]	14,1	25,6	35,8	59,0
Partial safety factor	γ_{Ms}	[-]	1,87			
Pullout failure						
Characteristic resistance in cracked concrete C20/25	$N_{Rk,p}$	[kN]	5	9	12	20
Pullout and splitting (Choice of minimum spacing and edge distance)						
Characteristic resistance in non-cracked concrete C20/25	$N_{Rk,p}$	[kN]	9	12	16	25
Respective spacing	$s_{cr,sp}$	[mm]	3 h_{ef}			
Respective edge distance	$c_{cr,sp}$	[mm]	1,5 h_{ef}			
Pullout and splitting (Choice of maximum resistance)						
Characteristic resistance in non-cracked concrete C20/25	$N_{Rk,p}$	[kN]	12	16	20	30
Respective spacing	$s_{cr,sp}$	[mm]	5 h_{ef}			
Respective edge distance	$c_{cr,sp}$	[mm]	2,5 h_{ef}			
Increasing factors for $N_{Rk,p}$ for cracked and non-cracked concrete	ψ_C C30/37	[-]	1,22			
	C40/50	[-]	1,41			
	C50/60	[-]	1,55			
Concrete cone failure						
Effective anchoring depth	h_{ef}	[mm]	45	58	65	80
Spacing	$s_{cr,N}$	[mm]	3 h_{ef}			
Edge distance	$c_{cr,N}$	[mm]	1,5 h_{ef}			
Partial safety factor	$\gamma_{Mp} = \gamma_{Msp} = \gamma_{Mc}$	[-]	1,8			

Table 25: Displacements under tension loads

Anchor size			M6	M8	M10	M12
Tension load in cracked concrete	N	[kN]	2,0	3,6	4,8	8,0
Displacement	δ_{N0}	[mm]	0,6	0,6	0,8	1,0
	$\delta_{N\infty}$	[mm]	0,8	0,8	1,2	1,4
Tension load in non-cracked concrete	N	[kN]	4,8	6,4	8,0	12,0
Displacement	δ_{N0}	[mm]	0,4	0,5	0,7	0,8
	$\delta_{N\infty}$	[mm]	0,8	0,8	1,2	1,4

JCP Option 1 Throughbolt and Option 1 Throughbolt ITS

**Characteristic values for tension loads, ETAG 001, Annex C
Displacements under tension loads, Option 1 Throughbolt ITS**

Annex 26

Table 26: Characteristic values for shear loads, ETAG 001, Annex C, Option 1 Throughbolt ITS

Anchor size			M6	M8	M10	M12
Option 1 Throughbolt ITS zinc plated						
Steel failure without lever arm, Installation type V						
Characteristic resistance	$V_{Rk,s}$	[kN]	5,8	6,9	10,4	25,8
Steel failure without lever arm, Installation type D						
Characteristic resistance	$V_{Rk,s}$	[kN]	5,1	7,6	10,8	24,3
Steel failure with lever arm, Installation type V						
Characteristic bending resistance	$M^0_{Rk,s}$	[Nm]	12,2	30,0	59,8	104,6
Steel failure with lever arm, Installation type D						
Characteristic bending resistance	$M^0_{Rk,s}$	[Nm]	36,0	53,2	76,0	207
Partial safety factor for $V_{Rk,s}$ (type V, D) and $M^0_{Rk,s}$ (type V, D)	γ_{Ms}	[-]	1,25			
Option 1 Throughbolt ITS stainless steel A4 and high corrosion resistant steel HCR						
Steel failure without lever arm, Installation type V						
Characteristic resistance	$V_{Rk,s}$	[kN]	5,7	9,2	10,6	23,6
Partial safety factor	γ_{Ms}	[-]	1,25			
Steel failure without lever arm, Installation type D						
Characteristic resistance	$V_{Rk,s}$	[kN]	7,3	7,6	9,7	29,6
Partial safety factor	γ_{Ms}	[-]	1,25			
Steel failure with lever arm, Installation type V						
Characteristic bending resistance	$M^0_{Rk,s}$	[Nm]	10,7	26,2	52,3	91,6
Partial safety factor	γ_{Ms}	[-]	1,56			
Steel failure with lever arm, Installation type D						
Characteristic bending resistance	$M^0_{Rk,s}$	[Nm]	28,2	44,3	69,9	191,2
Partial safety factor	γ_{Ms}	[-]	1,25			
Concrete pryout failure						
Factor in equation (5.6) ETAG 001, Annex C, 5.2.3.3	k	[-]	1,5	1,5	2,0	2,0
Partial safety factor	γ_{Mcp}	[-]	1,5			
Concrete edge failure						
Effective length of anchor in shear loading	l_f	[mm]	45	58	65	80
Effective diameter of anchor	d_{nom}	[mm]	8	10	12	16
Partial safety factor	γ_{Mc}	[-]	1,5			

Table 27: Displacements under shear loads, Option 1 Throughbolt ITS

Anchor size			M6	M8	M10	M12
Shear load in cracked and non-cracked concrete	V	[kN]	4,2	5,3	6,2	16,9
Displacements	δ_{V0}	[mm]	2,8	2,9	2,5	3,6
	$\delta_{V\infty}$	[mm]	4,2	4,4	3,8	5,3

JCP Option 1 Throughbolt and Option 1 Throughbolt ITS

Characteristic values for shear loads, ETAG 001, Annex C, Displacements under shear loads, Option 1 Throughbolt ITS

Annex 27

Table 28: Characteristic values to tension loads under fire exposure in cracked and non-cracked concrete C20/25 to C50/60, Annex C, Option 1 Throughbolt ITS

Anchor size	M 6			M 8			M 10			M 12						
	30	60	90	120	30	60	90	120	30	60	90	120				
Fire resistance duration R... [min]	30	60	90	120	30	60	90	120	30	60	90	120				
Steel failure:																
Characteristic resistance $N_{Rk,s,fi}$ [kN]	Steel zinc plated															
	0,7	0,6	0,5	0,4	1,4	1,2	0,9	0,8	2,5	2,0	1,5	1,3	3,7	2,9	2,2	1,8
Characteristic resistance $N_{Rk,p,fi}$ [kN]	Stainless steel A4 / HCR															
	2,9	1,9	1,0	0,5	5,4	3,8	2,1	1,3	8,7	6,3	3,9	2,7	12,6	9,2	5,7	4,0
Pullout failure:																
Characteristic resistance in concrete C20/25 to C50/60 $N_{Rk,p,fi}$ [kN]	1,3	1,3	1,0	1,0	2,3	2,3	1,8	1,8	3,0	3,0	2,4	2,4	5,0	5,0	4,0	4,0
Concrete cone failure:																
Characteristic resistance in concrete C20/25 to C50/60 $N^0_{Rk,c,fi}$ [kN]	2,4	2,4	2,0	2,0	4,6	4,6	3,7	3,7	6,1	6,1	4,9	4,9	10,3	10,3	8,2	8,2
Spacing $S_{cr,N,fi}$	4 x h_{ef}															
Edge Distance $C_{cr,N,fi}$	2 x h_{ef}															
Minimum spacing and edge distance under fire exposure from one side	according to Annex 23															
Minimum spacing and edge distance under fire exposure from more than one size	S_{min} according to Annex 23; $C_{min} \geq 300$ mm.															

In absence of other national regulations the partial safety factor for resistance under fire exposure $\gamma_{M,fi} = 1,0$ is recommended.

JCP Option 1 Throughbolt and Option 1 Throughbolt ITS

Characteristic values of tension resistance under fire exposure, ETAG001, Annex C, Option 1 Throughbolt ITS

Annex 28

Table 29: Characteristic values to tension loads under fire exposure in cracked and non-cracked concrete C20/25 to C50/60, ETAG 001, Annex C, Option 1 Throughbolt ITS

Anchor size:	M6			M8			M10			M12									
	30	60	90	120	30	60	90	120	30	60	90	120							
Fire resistance duration R... [min]	30	60	90	120	30	60	90	120	30	60	90	120							
Steel failure without lever arm:																			
Characteristic $V_{Rk,s,fi}$ resistance [kN]	Steel			0,7	0,6	0,5	0,4	1,4	1,2	0,9	0,8	2,5	2,0	1,5	1,3	3,7	2,9	2,2	1,8
	Zinc plated																		
Characteristic $M_{Rk,s,fi}^0$ Resistance [Nm]	Steel			2,2	1,5	0,7	0,4	5,5	3,9	2,2	1,3	11,2	8,1	5,1	3,5	19,6	14,3	8,9	6,2
	Stainless steel A4 / HCR																		
Steel failure with lever arm:																			
Characteristic $M_{Rk,s,fi}^0$ Resistance [Nm]	Steel			0,5	0,4	0,4	0,3	1,4	1,2	0,9	0,8	3,3	2,6	2,0	1,6	5,7	4,6	3,4	2,8
	A4 / HCR																		
Concrete pryout failure:																			
In Equation (5.6) of ETAG 001, Annex C, 5.2.3.3 the k-factor of Table 26 and the relevant values of $N_{Rk,c,fi}^0$ of Table 28 have to be considered.																			
Concrete edge failure:																			
The initial value $V_{Rk,c,fi}^0$ of the characteristic resistance in concrete C20/25 to C50/60 under fire exposure may be determined by: $V_{Rk,c,fi}^0 = 0,25 \times V_{Rk,c}^0 \quad (R30, R60, R90) \qquad V_{Rk,c,fi}^0 = 0,20 \times V_{Rk,c}^0 \quad (R120)$ with $V_{Rk,c}^0$ initial value if the characteristic resistance in cracked concrete C20/25 under normal temperature.																			
In absence of other national regulations the partial safety factor for resistance under fire exposure $\gamma_{M,fi} = 1,0$ is recommended.																			

JCP Option 1 Throughbolt and Option 1 Throughbolt ITS

Characteristic values of shear resistance under fire exposure, ETAG 001, Annex C, Option 1 Throughbolt ITS

Annex 29

Table 30: Characteristic values for tension loads, CEN/TS 1992-4, Option 1 Throughbolt ITS

Anchor size			M6	M8	M10	M12	
Steel failure							
Characteristic resistance, steel zinc plated	$N_{Rk,s}$	[kN]	16,1	22,6	26,0	56,6	
Partial safety factor	γ_{Ms}	[-]	1,5				
Characteristic resistance, stainless steel A4 and high corrosion resistant steel HCR	$N_{Rk,s}$	[kN]	14,1	25,6	35,8	59,0	
Partial safety factor	γ_{Ms}	[-]	1,87				
Pullout failure							
Characteristic resistance in cracked concrete C20/25	$N_{Rk,p}$	[kN]	5	9	12	20	
Pullout and splitting (Choice of minimum spacing and edge distance)							
Characteristic resistance in non-cracked concrete C20/25	$N_{Rk,p}$	[kN]	9	12	16	25	
Respective spacing	$s_{cr,sp}$	[mm]	3 h_{ef}				
Respective edge distance	$c_{cr,sp}$	[mm]	1,5 h_{ef}				
Pullout and splitting (Choice of maximum resistance)							
Characteristic resistance in non-cracked concrete C20/25	$N_{Rk,p}$	[kN]	12	16	20	30	
Respective spacing	$s_{cr,sp}$	[mm]	5 h_{ef}				
Respective edge distance	$c_{cr,sp}$	[mm]	2,5 h_{ef}				
Increasing factors for $N_{Rk,p}$ for cracked and non-cracked concrete	ψ_C	C30/37	[-]				1,22
		C40/50	[-]				1,41
		C50/60	[-]				1,55
Concrete cone failure							
Effective anchoring depth	h_{ef}	[mm]	45	58	65	80	
Factor for cracked concrete	k_{cr}	[-]	7,2				
Factor for non-cracked concrete	k_{ucr}	[-]	10,1				
Spacing	$s_{cr,N}$	[mm]	3 h_{ef}				
Edge distance	$c_{cr,N}$	[mm]	1,5 h_{ef}				
Partial safety factor	$\gamma_{Mp} = \gamma_{Msp} = \gamma_{Mc}$	[-]	1,8				

Table 31: Displacements under tension loads, Option 1 Throughbolt ITS

Anchor size			M6	M8	M10	M12
Tension load in cracked concrete	N	[kN]	2,0	3,6	4,8	8,0
Displacement	δ_{N0}	[mm]	0,6	0,6	0,8	1,0
	$\delta_{N\infty}$	[mm]	0,8	0,8	1,2	1,4
Tension load in non-cracked concrete	N	[kN]	4,8	6,4	8,0	12,0
Displacement	δ_{N0}	[mm]	0,4	0,5	0,7	0,8
	$\delta_{N\infty}$	[mm]	0,8	0,8	1,2	1,4

JCP Option 1 Throughbolt and Option 1 Throughbolt ITS

Characteristic values for tension loads, CEN/TS 1992-4, Displacements under tension loads, Option 1 Throughbolt ITS

Annex 30

Table 32: Characteristic values for shear loads, CEN/TS 1992-4, Option 1 Throughbolt ITS

Anchor size		M6	M8	M10	M12
Option 1 Throughbolt ITS zinc plated					
Steel failure without lever arm, Installation type V					
Characteristic resistance	$V_{Rk,s}$ [kN]	5,8	6,9	10,4	25,8
Steel failure without lever arm, Installation type D					
Characteristic resistance	$V_{Rk,s}$ [kN]	5,1	7,6	10,8	24,3
Steel failure with lever arm, Installation type V					
Characteristic bending resistance	$M^0_{Rk,s}$ [Nm]	12,2	30,0	59,8	104,6
Steel failure with lever arm, Installation type D					
Characteristic bending resistance	$M^0_{Rk,s}$ [Nm]	36,0	53,2	76,0	207
Partial safety factor for $V_{Rk,s}$ (type V, D) and $M^0_{Rk,s}$ (type V, D)	γ_{Ms} [-]	1,25			
Factor of ductility	k_2 [-]	1,0			
Option 1 Throughbolt ITS stainless steel A4 and high corrosion resistant steel HCR					
Steel failure without lever arm, Installation type V					
Characteristic resistance	$V_{Rk,s}$ [kN]	5,7	9,2	10,6	23,6
Partial safety factor	γ_{Ms} [-]	1,25			
Steel failure without lever arm, Installation type D					
Characteristic resistance	$V_{Rk,s}$ [kN]	7,3	7,6	9,7	29,6
Partial safety factor	γ_{Ms} [-]	1,25			
Steel failure with lever arm, Installation type V					
Characteristic bending resistance	$M^0_{Rk,s}$ [Nm]	10,7	26,2	52,3	91,6
Partial safety factor	γ_{Ms} [-]	1,56			
Steel failure with lever arm, Installation type D					
Characteristic bending resistance	$M^0_{Rk,s}$ [Nm]	28,2	44,3	69,9	191,2
Partial safety factor	γ_{Ms} [-]	1,25			
Factor of ductility	k_2 [-]	1,0			
Concrete pryout failure					
Factor in equation (16) CEN/TS 1992-4-4, 5.2.2.3	k_3 [-]	1,5	1,5	2,0	2,0
Partial safety factor	γ_{Mcp} [-]	1,5			
Concrete edge failure					
Effective length of anchor in shear loading	l_f [mm]	45	58	65	80
Effective diameter of anchor	d_{nom} [mm]	8	10	12	16
Partial safety factor	γ_{Mc} [-]	1,5			

Table 33: Displacements under shear loads, Option 1 Throughbolt ITS

Anchor size		M6	M8	M10	M12
Shear load in cracked and non-cracked concrete	V [kN]	4,2	5,3	6,2	16,9
Displacements	δ_{V0} [mm]	2,8	2,9	2,5	3,6
	$\delta_{V\infty}$ [mm]	4,2	4,4	3,8	5,3

JCP Option 1 Throughbolt and Option 1 Throughbolt ITS

Characteristic values for shear loads, CEN/TS 1992-4, Displacements under shear loads, Option 1 Throughbolt ITS

Annex 31

Table 34: Characteristic values to tension loads under fire exposure in cracked and non-cracked concrete C20/25 to C50/60, CEN/TS 1992-4, Option 1 Throughbolt ITS

Anchor size	M 6			M 8			M 10			M 12														
	30	60	90	120	30	60	90	120	30	60	90	120												
Fire resistance duration R_{\dots} [min]	30	60	90	120	30	60	90	120	30	60	90	120												
Steel failure:																								
Characteristic resistance $N_{Rk,s,fi}$ [kN]	Steel zinc plated			0,7	0,6	0,5	0,4	1,4	1,2	0,9	0,8	1,5	1,3	2,0	2,5	3,7	2,9	2,2	1,8					
	Stainless steel A4 / HCR			2,9	1,9	1,0	0,5	5,4	3,8	2,1	1,3	8,7	6,3	3,9	2,7	12,6	9,2	5,7	4,0					
Pullout failure:																								
Characteristic resistance in concrete C20/25 to C50/60 $N_{Rk,p,fi}$ [kN]	1,3			1,0			2,3			1,8			3,0			2,4			5,0			4,0		
Concrete cone failure:																								
Characteristic resistance in concrete C20/25 to C50/60 $N^0_{Rk,c,fi}$ [kN]	2,4			2,0			4,6			3,7			6,1			4,9			10,3			8,2		
Spacing $S_{cr,N,fi}$	4 x h_{ef}																							
Edge Distance $C_{cr,N,fi}$	2 x h_{ef}																							
Minimum spacing and edge distance under fire exposure from one side	according to Annex 23																							
Minimum spacing and edge distance under fire exposure from more than one size	S_{min} according to Annex 23; $C_{min} \geq 300$ mm.																							
Partial safety factor $\gamma_{M,fi}$ [-]	1,0																							

JCP Option 1 Throughbolt and Option 1 Throughbolt ITS

Characteristic values of tension resistance
under fire exposure, CEN/TS 1992-4, Option 1 Throughbolt ITS

Annex 32

**Table 35: Characteristic values to tension loads under fire exposure
in cracked and non-cracked concrete C20/25 to C50/60, CEN/TS 1992-4, Option 1 Throughbolt ITS**

Anchor size:	M6			M8			M10			M12									
	30	60	90	120	30	60	90	120	30	60	90	120							
Fire resistance duration R... [min]	30	60	90	120	30	60	90	120	30	60	90	120							
Steel failure without lever arm:																			
Characteristic resistance $V_{Rk,s,fi}$ [kN]	Steel zinc plated			0,7	0,6	0,5	0,4	1,4	1,2	0,9	0,8	2,5	2,0	1,5	1,3	3,7	2,9	2,2	1,8
	Stainless steel A4 / HCR			2,9	1,9	1,0	0,5	5,4	3,8	2,1	1,3	8,7	6,3	3,9	2,7	12,6	9,2	5,7	4,0
Steel failure with lever arm:																			
Characteristic Resistance $M^0_{Rk,s,fi}$ [Nm]	Steel			0,5	0,4	0,4	0,3	1,4	1,2	0,9	0,8	3,3	2,6	2,0	1,6	5,7	4,6	3,4	2,8
	A4 / HCR			2,2	1,5	0,7	0,4	5,5	3,9	2,2	1,3	11,2	8,1	5,1	3,5	19,6	14,3	8,9	6,2
Concrete pryout failure:																			
In Equations (D.6 and D.7) of CEN/TS 1992-4-1, Annex D, D.3.3.2 the k-factor is similar to the k_3 -factor for normal temperature and the relevant values of $N^0_{Rk,c,fi}$ of Table 34 have to be considered.																			
Concrete edge failure:																			
The initial value $V^0_{Rk,c,fi}$ of the characteristic resistance in concrete C20/25 to C50/60 under fire exposure may be determined by: $V^0_{Rk,c,fi} = 0,25 \times V^0_{Rk,c} \text{ (R30, R60, R90)} \quad V^0_{Rk,c,fi} = 0,20 \times V^0_{Rk,c} \text{ (R120)}$ with $V^0_{Rk,c}$ initial value if the characteristic resistance in cracked concrete C20/25 under normal temperature.																			
Partial safety factor	$\gamma_{M,fi}$ [-]																		
												1,0							

JCP Option 1 Throughbolt and Option 1 Throughbolt ITS

Characteristic values of shear resistance
under fire exposure, CEN/TS 1992-4, Option 1 Throughbolt ITS

Annex 33