



European Technical Approval ETA-13/0725

English translation prepared by DIBt - Original version in German language

Handelsbezeichnung <i>Trade name</i>	Vorpa Rahmen/Multi-Funktionsdübel VP C <i>Vorpa frame/multi-purpose anchor VP C</i>
Zulassungsinhaber <i>Holder of approval</i>	VORPA srl Via S. Leo 5 47838 Riccione (RN) ITALIEN
Zulassungsgegenstand und Verwendungszweck <i>Generic type and use of construction product</i>	Kunststoffdübel als Mehrfachbefestigung von nichttragenden Systemen zur Verankerung in Beton und Mauerwerk <i>Plastic anchor for multiple use in concrete and masonry for non- structural applications</i>
Geltungsdauer: <i>Validity:</i>	vom <i>from</i> bis <i>to</i> 13 June 2013 21 March 2018
Herstellwerke <i>Manufacturing plants</i>	Italien- Herstellwerk 1 Italy- Plant 1

Diese Zulassung umfasst
This Approval contains

22 Seiten einschließlich 11 Anhänge
22 pages including 11 annexes

I LEGAL BASES AND GENERAL CONDITIONS

- 1 This European technical approval is issued by Deutsches Institut für Bautechnik in accordance with:
 - Council Directive 89/106/EEC of 21 December 1988 on the approximation of laws, regulations and administrative provisions of Member States relating to construction products¹, modified by Council Directive 93/68/EEC² and Regulation (EC) N° 1882/2003 of the European Parliament and of the Council³;
 - Gesetz über das In-Verkehr-Bringen von und den freien Warenverkehr mit Bauprodukten zur Umsetzung der Richtlinie 89/106/EWG des Rates vom 21. Dezember 1988 zur Angleichung der Rechts- und Verwaltungsvorschriften der Mitgliedstaaten über Bauprodukte und anderer Rechtsakte der Europäischen Gemeinschaften (Bauproduktengesetz - BauPG) vom 28. April 1998⁴, as amended by Article 2 of the law of 8 November 2011⁵;
 - Common Procedural Rules for Requesting, Preparing and the Granting of European technical approvals set out in the Annex to Commission Decision 94/23/EC⁶;
 - Guideline for European technical approval of "Plastic Anchors for Multiple Use in Concrete and Masonry for Non-structural Applications - Part 1: General", ETAG 020-01.
- 2 Deutsches Institut für Bautechnik is authorized to check whether the provisions of this European technical approval are met. Checking may take place in the manufacturing plant. Nevertheless, the responsibility for the conformity of the products to the European technical approval and for their fitness for the intended use remains with the holder of the European technical approval.
- 3 This European technical approval is not to be transferred to manufacturers or agents of manufacturers other than those indicated on page 1, or manufacturing plants other than those indicated on page 1 of this European technical approval.
- 4 This European technical approval may be withdrawn by Deutsches Institut für Bautechnik, in particular pursuant to information by the Commission according to Article 5(1) of Council Directive 89/106/EEC.
- 5 Reproduction of this European technical approval including transmission by electronic means shall be in full. However, partial reproduction can be made with the written consent of Deutsches Institut für Bautechnik. In this case partial reproduction has to be designated as such. Texts and drawings of advertising brochures shall not contradict or misuse the European technical approval.
- 6 The European technical approval is issued by the approval body in its official language. This version corresponds fully to the version circulated within EOTA. Translations into other languages have to be designated as such.

¹ Official Journal of the European Communities L 40, 11 February 1989, p. 12
² Official Journal of the European Communities L 220, 30 August 1993, p. 1
³ Official Journal of the European Union L 284, 31 October 2003, p. 25
⁴ *Bundesgesetzblatt Teil I* 1998, p. 812
⁵ *Bundesgesetzblatt Teil I* 2011, p. 2178
⁶ Official Journal of the European Communities L 17, 20 January 1994, p. 34

II SPECIFIC CONDITIONS OF THE EUROPEAN TECHNICAL APPROVAL

1 Definition of product and intended use

1.1 Definition of the construction product

The frame anchor Vorpa VP C is a plastic anchor consisting of a plastic sleeve made of polyamide and an accompanying specific screw of galvanised steel or of stainless steel.

The plastic sleeve is expanded by screwing in the specific screw which presses the sleeve against the wall of the drilled hole.

The installed anchor is shown in Annex 1.

1.2 Intended use

The anchor is intended to be used for anchorages for which requirements for safety in use in the sense of the Essential Requirement 4 of Council Directive 89/106/EEC shall be fulfilled and failure of the fixture represents an immediate risk to human life.

The anchor is to be used only for multiple fixing for non-structural applications.

The base material may consist of use category a, b and c as given in the following Table:

Use category	Anchor type	Remarks
a	Vorpa VP C	<ul style="list-style-type: none"> Concrete with strength class C12/15 at minimum and C50/60 at maximum according to EN 206-1:2000-12 Cracked and non-cracked concrete The anchor may also be used with requirements related to resistance to fire according 4.2.2.
b	Vorpa VP C	<ul style="list-style-type: none"> Masonry walls according to Annex 6 Mortar strength class \geq M 2,5 according to EN 998-2:2003
c	Vorpa VP C	<ul style="list-style-type: none"> Masonry walls according to Annex 8 Mortar strength class \geq M 2,5 according to EN 998-2:2003

Specific screw of galvanised steel:

The specific screw made of galvanised steel may only be used in structures subject to dry internal conditions.

The specific screw may also be used in structures subject to external atmospheric exposure or exposure in permanently damp internal conditions, if the area of the head of the screw is protected against moisture and driving rain after mounting of the fixing unit in this way, that intrusion of moisture into the anchor shaft is prevented. Therefore there shall be an external cladding or a ventilated rainscreen mounted in front of the head of the screw and the head of the screw itself shall be coated with a soft plastic, permanently elastic bitumen-oil-combination coating (e. g. undercoating or body cavity protection for cars).

Specific screw of stainless steel:

The specific screw made of stainless steel may be used in structures subject to dry internal conditions and also in structures subject to external atmospheric exposure (including industrial and marine environment), or exposure in permanently damp internal conditions, if no particular aggressive conditions exist. Such particular aggressive conditions are e. g. permanent, alternating immersion in seawater or the splash zone of seawater, chloride atmosphere of indoor swimming pools or atmosphere with extreme chemical pollution (e. g. in desulphurization plants or road tunnels where de-icing materials are used).

The anchor may be used in the following temperature range:

Temperature range a):	-40 °C to +40 °C	(max long term temperature +24 °C and max short term temperature +40 °C)
Temperature range b):	-40 °C to +80 °C	(max long term temperature +50 °C and max short term temperature +80 °C)

The provisions made in this European technical approval are based on an assumed working life of the anchor of 50 years. The indications given on the working life cannot be interpreted as a guarantee given by the producer, but are to be regarded only as a means for choosing the right products in relation to the expected economically reasonable working life of the works.

2 Characteristics of the product and methods of verification

2.1 Characteristics of the product

The anchor corresponds to the drawings and information given in Annex 1, 2 and 3. The characteristic material values, dimensions and tolerances of the anchor not given in these Annexes shall correspond to the respective values laid down in the technical documentation⁷ of this European technical approval.

The characteristic values for the design of the anchorages are given in Annex 4 to 11.

Each anchor is to be marked with the identifying mark, the type, the diameter and the length of the anchor according to Annex 2.

The minimum embedment depths shall be marked.

The anchor shall only be packaged and supplied as a complete unit.

In addition to the specific clauses relating to dangerous substances contained in this European technical approval, there may be other requirements applicable to the products falling within its scope (e. g. transposed European legislation and national laws, regulations and administrative provisions). In order to meet the provisions of the Construction Products Directive, these requirements need also to be complied with, when and where they apply.

2.2 Methods of verification

The assessment of the fitness of the anchor for the intended use in relation to the requirements for safety in use in the sense of the Essential Requirement 4 has been made in compliance with the Guideline for European technical approval of "Plastic Anchors for Multiple Use in Concrete and Masonry for Non-structural Applications", ETAG 020,

⁷ The technical documentation of this European technical approval is deposited at the Deutsches Institut für Bautechnik and, as far as relevant for the tasks of the approved bodies involved in the attestation of conformity procedure, is handed over to the approved bodies.

- Part 1: "General",
- Part 2: "Plastic Anchors for Use in Normal Weight Concrete",
- Part 3: "Plastic Anchors for Use in Solid Masonry Materials" and
- Part 4: "Plastic Anchors for Use in Hollow or Perforated Masonry",
based on the use categories a, b and c.

3 Evaluation and attestation of conformity and CE marking

3.1 System of attestation of conformity

According to the decision 97/463/EG of the European Commission⁸ the system 2(ii) (referred to as system 2+) of attestation of conformity applies.

This system of attestation of conformity is defined as follows.

System 2+: Declaration of conformity of the product by the manufacturer on the basis of:

- (a) Tasks for the manufacturer:
 - (1) initial type-testing of the product;
 - (2) factory production control;
 - (3) testing of samples taken at the factory in accordance with a prescribed control plan.
- (b) Tasks for the approved body:
 - (4) certification of factory production control on the basis of:
 - initial inspection of factory and of factory production control;
 - continuous surveillance, assessment and approval of factory production control.

3.2 Responsibilities

3.2.1 Tasks of the manufacturer

3.2.1.1 Factory production control

The manufacturer shall exercise permanent internal control of production. All the elements, requirements and provisions adopted by the manufacturer shall be documented in a systematic manner in the form of written policies and procedures, including records of results performed. This production control system shall insure that the product is in conformity with this European technical approval.

The manufacturer may only use raw materials stated in the technical documentation of this European technical approval.

The factory production control shall be in accordance with the control plan which is part of the technical documentation of this European technical approval. The control plan is laid down in the context of the factory production control system operated by the manufacturer and deposited at Deutsches Institut für Bautechnik.⁹

The results of factory production control shall be recorded and evaluated in accordance with the provisions of the control plan.

3.2.1.2 Other tasks of manufacturer

The manufacturer shall, on the basis of a contract, involve a body which is approved for the tasks referred to in section 3.1 in the field of anchors in order to undertake the actions laid down in section 3.2.2. For this purpose, the control plan referred to in sections 3.2.1.1 and 3.2.2 shall be handed over by the manufacturer to the approved body involved.

⁸ Official Journal of the European Communities L 198 of 25.07.1997.

⁹ The control plan is a confidential part of the documentation of the European technical approval, but not published together with the ETA and only handed over to the approved body involved in the procedure of attestation of conformity. See section 3.2.2.

The manufacturer shall make a declaration of conformity, stating that the construction product is in conformity with the provisions of this European technical approval.

3.2.2 Tasks of approved bodies

The approved body shall perform the

- initial inspection of factory and of factory production control,
- continuous surveillance, assessment and approval of factory production control, in accordance with the provisions laid down in the control plan.

The approved body shall retain the essential points of its actions referred to above and state the results obtained and conclusions drawn in a written report.

The approved certification body involved by the manufacturer shall issue an EC certificate of conformity of the factory production control stating the conformity with the factory production control of this European technical approval.

In cases where the provisions of the European technical approval and its control plan are no longer fulfilled the certification body shall withdraw the certificate of conformity and inform Deutsches Institut für Bautechnik without delay.

3.3 CE marking

The CE marking shall be affixed on each packaging of the anchor. The letters "CE" shall be followed by the identification number of the approved certification body, where relevant, and be accompanied by the following additional information:

- the name and address of the producer (legal entity responsible for the manufacturer),
- the last two digits of the year in which the CE marking was affixed,
- the number of the EC certificate for the factory production control,
- the number of the European technical approval,
- the number of the guideline for European technical approval,
- use category a, b and c.

4 Assumptions under which the fitness of the product for the intended use was favourably assessed

4.1 Manufacturing

The European technical approval is issued for the product on the basis of agreed data/information, deposited with Deutsches Institut für Bautechnik, which identifies the product that has been assessed and judged. Changes to the product or production process, which could result in this deposited data/information being incorrect, should be notified to Deutsches Institut für Bautechnik before the changes are introduced. Deutsches Institut für Bautechnik will decide whether or not such changes affect the ETA and consequently the validity of the CE marking on the basis of the ETA and if so whether further assessment or alterations to the ETA shall be necessary.

4.2 Design of anchorages

4.2.1 General

Fitness for the intended use of the anchor is given under the following conditions:

- The design of anchorages is carried out in compliance with ETAG 020, Guideline for European technical approval of "Plastic Anchors for Multiple Use in Concrete and Masonry for Non-structural Applications", Annex C under the responsibility of an engineer experienced in anchorages.

- Verifiable calculation notes and drawings shall be prepared taking account of the loads to be anchored, the nature and strength of the base materials and the dimensions of the anchorage members as well as of the relevant tolerances.
- The anchor is to be used only for multiple fixing for non-structural applications.

Therefore the design of the fixture may specify the number n_1 of fixing points to fasten the fixture and the number n_2 of anchors per fixing point. Furthermore the design value of actions N_{Sd} on a fixing point to a value $\leq n_3$ (kN) is specified up to which the strength and stiffness of the fixture are fulfilled and the load transfer in the case of excessive slip or failure of one anchor need not be taken into account in the design of the fixture.

The following default values for n_1 , n_2 and n_3 may be taken:

$$n_1 \geq 4; \quad n_2 \geq 1 \quad \text{and} \quad n_3 \leq 4,5 \text{ kN} \quad \text{or}$$

$$n_1 \geq 3; \quad n_2 \geq 1 \quad \text{and} \quad n_3 \leq 3,0 \text{ kN}.$$

- Shear loads acting on an anchor may be assumed to act without lever arm if both of the following conditions are fulfilled:
 - The fixture shall be made of metal and in the area of the anchorage be fixed directly to the base material either without an intermediate layer or with a levelling layer of mortar with a thickness ≤ 3 mm.
 - The fixture shall be in contact with the anchor over its entire thickness. (Therefore the diameter of clearance hole in the fixture d_f has to be equal or smaller than the value given in Annex 3, Table 2.)

If these two conditions are not fulfilled the lever arm is calculated according to ETAG 020, Annex C. The characteristic bending moment is given in Annex 4, Table 4.

4.2.2 Resistance in concrete (use category "a")

The characteristic values of resistance of the anchor for use in concrete are given in Annex 4. The design method is valid for cracked and non-cracked concrete.

According to the EOTA Technical Report TR 020 "Evaluation of anchorages in concrete concerning resistance to fire" it can be assumed that for fastening of facade systems the load bearing behaviour of the Vorpa VP C Ø 10, has a sufficient resistance to fire at least 90 minutes (R90) if the admissible load $[F_{Rk} / (\gamma_M \cdot \gamma_F)]$ is $\leq 0,8$ kN (no permanent centric tension load).

4.2.3 Resistance in solid masonry (use category "b")

The characteristic values of resistance of the anchor for use in solid masonry are given in Annex 6. These values are independent of the load direction (tension, shear or combined tension and shear) and the mode of failure.

The characteristic resistances given in Annex 6 for use in solid masonry are only valid for the base material and the bricks according this table or larger brick sizes and larger compressive strength of the masonry unit.

The influence of larger embedment depths, lower mortar strength and/or different bricks and blocks (according Annex 6 regarding base material, size of the units, compressive strength) has to be detected by job site tests according to 4.4.

4.2.4 Resistance in hollow or perforated masonry (use category "c")

The characteristic values of resistance of the anchor for use in hollow or perforated masonry are given in Annex 8. These values are independent of the load direction (tension, shear or combined tension and shear) and the mode of failure.

The given characteristic resistances are only valid for the bricks and blocks according this table regarding base material, size of the units, compressive strength and configuration of the voids.

The influence of larger embedment depths, lower mortar strength and/or different bricks and blocks (according Annex 8 regarding base material, size of the units, compressive strength and configuration of the voids) has to be detected by job site tests according to 4.4.

4.2.5 Specific conditions for the design method in solid masonry and hollow or perforated masonry

The mortar strength class of the masonry has to be M 2,5 according to EN 998-2:2003 at minimum.

The characteristic resistance F_{Rk} for a single plastic anchor may also be taken for a group of two or four plastic anchors with a spacing equal or larger than the minimum spacing s_{min} .

The distance between single plastic anchors or a group of anchors should be $a \geq 250$ mm.

If the vertical joints of the wall are designed not to be filled with mortar then the design resistance N_{Rd} has to be limited to 2,0 kN to ensure that a pull-out of one brick out of the wall will be prevented. This limitation can be omitted if interlocking units are used for the wall or when the joints are designed to be filled with mortar.

If the joints of the masonry are not visible the characteristic resistance F_{Rk} has to be reduced with the factor $\alpha_j = 0,5$.

If the joints of the masonry are visible (e.g. unplastered wall) following has to be taken into account:

- The characteristic resistance F_{Rk} may be used only, if the wall is designed such that the joints are to be filled with mortar.
- If the wall is designed such that the joints are not to be filled with mortar then the characteristic resistance F_{Rk} may be used only, if the minimum edge distance c_{min} to the vertical joints is observed. If this minimum edge distance c_{min} can not be observed then the characteristic resistance F_{Rk} has to be reduced with the factor $\alpha_j = 0,5$.

4.2.6 Characteristic values, spacing and dimensions of anchorage member

The minimum spacing and dimensions of anchorage member according to Annex 5, Table 9 and Annexes 10 and 11 shall be observed depending on the base material.

4.2.7 Displacement behaviour

The displacements under tension and shear loading in concrete and masonry are given in Annex 5, Table 7 and 8 and Annexes 7 and 9.

4.3 Installation of anchor

The fitness for use of the anchor can only be assumed if the following conditions of installation are met:

- Anchor installation carried out by appropriately qualified personnel under the supervision of the person responsible for technical matters on site.
- Use of the anchor only as supplied by the manufacturer without exchanging any component of the anchor.
- Anchor installation in accordance with the manufacturer's specifications and drawings using the tools indicated in this European technical approval.
- Checks before placing the anchor, to ensure that the characteristic values of the base material in which the anchor is to be placed, is identical with the values, which the characteristic loads apply for.

- Observation of the drill method according Annex 6 and 8 (Drill holes in hollow or perforated masonry may only be drilled using the rotary drill. Other drilling methods may also be used if job-site tests according to 4.4 evaluate the influence of hammer or impact drilling.).
- Placing drill holes without damaging the reinforcement.
- Observation of the overall plastic anchor embedment depth.
- Holes to be cleaned of drilling dust.
- In case of aborted hole: New drilling at a minimum distance away of twice the depth of the aborted hole or smaller distance if the aborted drill hole is filled with high strength mortar.
- The plastic sleeve is inserted through the fixture by slight hammer blows and the special screw is screwed in until the head of the screw touches the sleeve. The anchor is correct mounted, if there is no turn-through of the plastic sleeve in the drill hole and if slightly move on turning of the screw is impossible after the complete turn-in of the screw.
- Temperature during installation of the anchor ≥ 0 °C (plastic sleeve and base material).

4.4 Job site tests according to ETAG 020, Annex B

4.4.1 General

In the absence of national requirements the characteristic resistance of the plastic anchor may be determined by job site tests, if the plastic anchor has already characteristic values given in Annex 6 and 8 for the same base material as it is present on the construction works.

Furthermore job site tests for use in different solid masonry and hollow or perforated masonry are possible only if the plastic anchor has already characteristic values given in Annex 6 and 8 for use in the equivalent base material.

Job site tests are also possible, if another drill method is been used as it is given in Annex 6 and 8.

The characteristic resistance to be applied to a plastic anchor should be determined by means of at least 15 pull-out tests carried out on the construction work with a centric tension load acting on the plastic anchor. These tests may also performed in a laboratory under equivalent conditions as used on construction work.

Execution and evaluation of the tests as well as issue of the test report and determination of the characteristic resistance should be supervised by the person responsible for execution of works on site and be carried out by a competent person.

Number and position of the plastic anchors to be tested should be adapted to the relevant special conditions of the construction work in question and, for example, in the case of blind and larger areas be increased such that a reliable information about the characteristic resistance of the plastic anchor embedded in the base material in question can be derived. The tests should take account of the unfavourable conditions of practical execution.

4.4.2 Assembly

The plastic anchor to be tested shall be installed (e. g. preparation of drill hole, drilling tool to be used, drill bit, type of drilling hammer or rotation, thickness of fixture) and as far as spacing and edge distances are concerned be distributed in the same way as foreseen for the intended use.

Depending on the drilling tool hard metal hammer drill bits or hard metal percussion drill bits, respectively, according to ISO 5468 should be used. New drill bits should be used for one test series or drill bits with $d_{\text{cut,m}} = 8,25 \text{ mm} < d_{\text{cut}} \leq 8,45 \text{ mm} = d_{\text{cut,max}}$ or $d_{\text{cut,m}} = 10,25 \text{ mm} < d_{\text{cut}} \leq 10,45 \text{ mm} = d_{\text{cut,max}}$ respective.

4.4.3 Execution of test

The test rig used for the pull-out tests shall provide a continuous slow increase of the load, controlled by a calibrated load cell. The load shall apply perpendicular to the surface of the base material and shall be transmitted to the anchor via a hinge. The reaction forces shall be transmitted into the base material such that possible breakout of the masonry is not restricted. This condition is considered as fulfilled, if the support reaction forces are transmitted either in adjacent masonry units or at a distance of at least 150 mm from the plastic anchors. The load shall be increased continuously in a way that the ultimate load is reached after about 1 minute. The load is measured when the ultimate load (N_1) is achieved.

If no pull-out failure occurs, other test methods are needed, e.g. proof-loading.

4.4.4 Test report

The test report shall include all information necessary to assess the resistance of the tested anchor. It shall be given to the person responsible for the design of the fastening and shall be included in the construction dossier.

The minimum data required are:

- Name of product
- Construction site, owner of building; date and location of the tests, air temperature
- Test rig
- Type of structure to be fixed
- Base material (e.g. type of brick, strength class, all dimensions of bricks, mortar group if possible); visual assessment of masonry (flush joints, joint clearance, regularity)
- Plastic anchor and special screw
- value of the cutting diameter of hard metal hammer-drill bits, measured before and after drilling if no new drill bits are used
- Results of tests including the indication of value N_1 ; mode of failure
- Tests carried out or supervised by ...; signature

4.4.5 Evaluation of test results

The characteristic resistance F_{RK1} is derived from the measured values N_1 as follows

$$F_{\text{RK1}} = 0,5 \cdot N_1$$

The characteristic resistance F_{RK1} has to be equal or smaller than the characteristic resistance F_{RK} which is given in the ETA for the equivalent base material

$$N_1 = \text{the mean value of the five smallest measured values at ultimate load}$$

In absence of national regulations the partial safety factors for the resistance of the plastic anchor may be taken as $\gamma_{\text{Mm}} = 2,5$ for use in masonry.

5 Indications to the manufacturer

5.1 Responsibility of the manufacturer

It is in the responsibility of the manufacturer to ensure that the information on the specific conditions according to 1 and 2 including Annexes referred to 4 is given to those who are concerned. This information may be made by reproduction of the respective parts of the European technical approval. In addition, all installation data shall be shown clearly on the packaging and/or on an enclosed instruction sheet, preferably using illustrations.

The minimum data required are:

- base material for the intended use,
- ambient temperature of the base material during installation of the anchor,
- drill bit diameter (d_{cut}),
- overall anchor embedment depth in the base material (h_{nom}),
- minimum hole depth (h_0),
- information on the installation procedure,
- identification of the manufacturing batch.

All data shall be presented in a clear and explicit form.

5.2 Packaging, transport and storage

The anchor shall only be packaged and supplied as a complete unit.

The anchor shall be stored under normal climatic conditions in its original light-proof packaging. Before installation, it shall not be extremely dried nor frozen.

Andreas Kummerow
p. p. Head of Department

beglaubigt:
Bürger

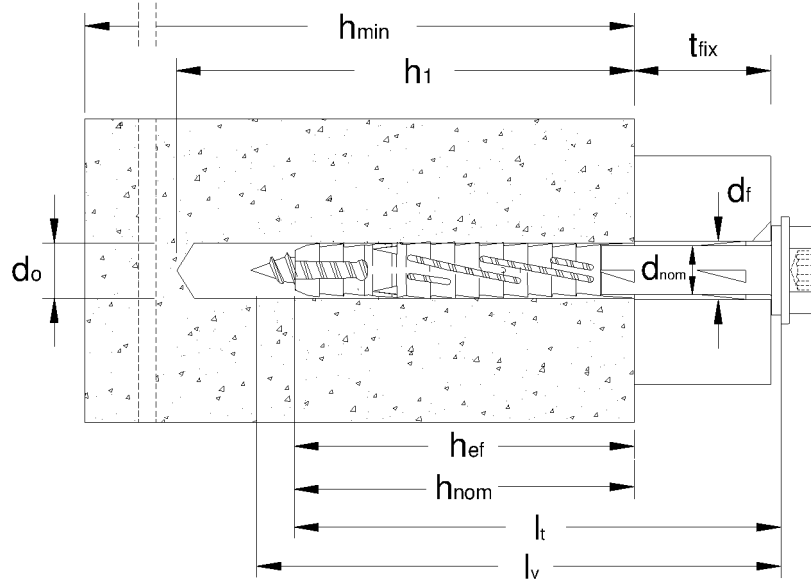

Intended Use:

Fixing in concrete and different types of masonry.

Legend:

- h_{min} : minimum thickness of concrete member
- h_{nom} : minimum overall embedment depth
- h_{ef} : minimum effective embedment depth
- d_{nom} : anchor diameter
- l_t : anchor length
- l_v : screw length
- d_0 : drill hole diameter
- h_1 : minimum depth of drill hole
- t_{fix} : maximum thickness of fixture
- d_f : diameter of clearance hole in the fixture

Vorpa frame/multi-purpose anchor VP C

Product and intended use

Annex 1

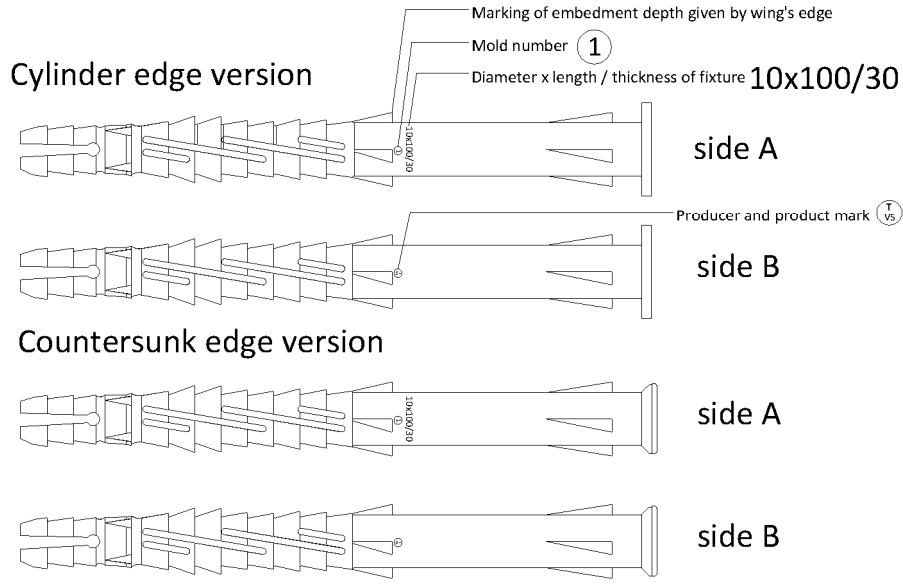

Special screw (Carbon steel version and stainless steel A4 version)

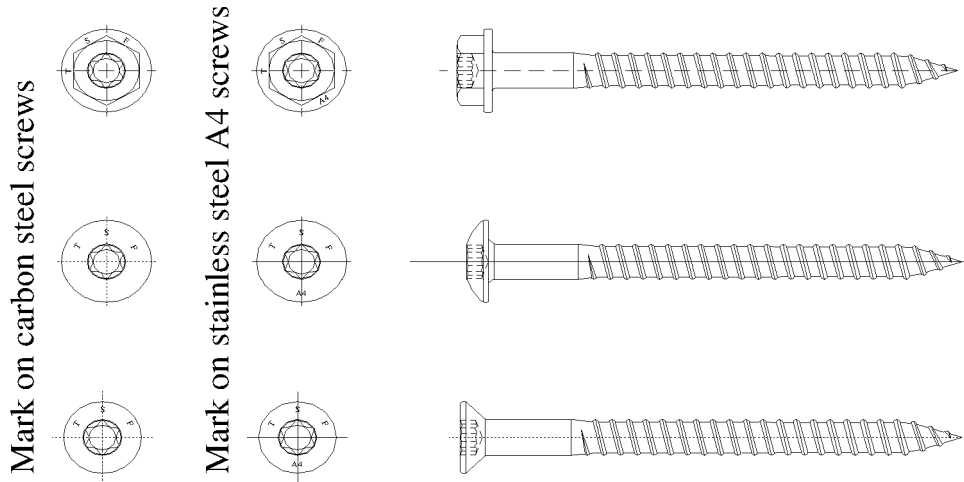

Vorpa frame/multi-purpose anchor VP C

Anchor types

Annex 2

Table 1 : Dimensions

Anchor type		VP C	VP C
		φ8	φ10
Outside diameter of anchor	$d_{nom} = [mm]$	8	10
Length of the anchor	$l_t = [mm]$	≥80	
Screw diameter	$d_v = [mm]$	6	7
Screw length	$l_v = [mm]$	≥85	≥85

Table 2 : Installation parameters

Nominal drill hole diameter	$d_o [mm]$	8	10
Cutting diameter of drill bit	$d_{cut} \leq [mm]$	8.45	10.45
Depth of drill hole	$h_1 = [mm]$	90	90
Effective anchorage depth	$h_{ef} = [mm]$	70	70
Diameter of clearance hole in the fixture	$d_f = [mm]$	9	11
Thickness of fixture	$t_{fix} = [mm]$	≥10	
Hexalobular socket number (ISO 10664)	T	30	40
Wrench size (for hexagonal head only)	SW = [mm]	10	13

Setting instructions

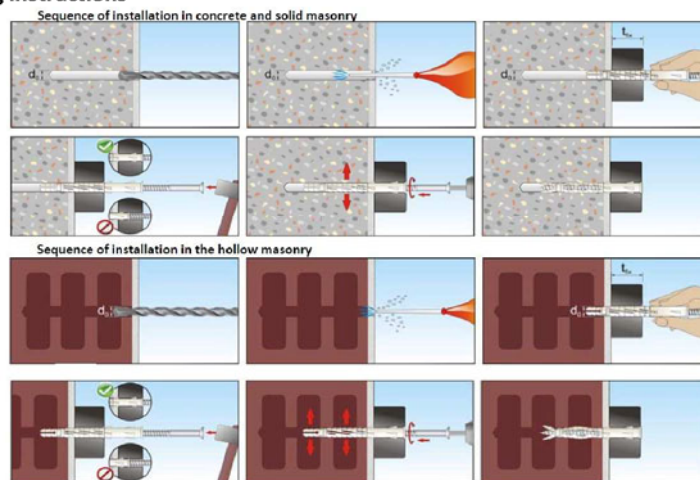

Table 3 : Materials

Anchor sleeve	Polyamide, PA 6, light grey color
Carbon steel screw	Carbon Steel C1022 grade 5.8, gvz min 5 µm acc. to ISO 2081
Stainless steel screw	SS A4/70 (AISI 316) acc. to ISO 3506-1 and EN 10088-3

Vorpa frame/multi-purpose anchor VP C

Annex 3

Dimensions, installation parameters and materials

Table 4 : Characteristic bending resistance of the screw

Parameter / Size			VP C φ 8		VP C φ 10	
			Galvanized steel	Stainless steel	Galvanized steel	Stainless steel
Characteristic bending resistance	$M_{Rk,s}$	[Nm]	12.1	16.9	19.3	27.1
Partial safety factor	γ_{Ms}	-	1.25			

Table 5 : Characteristic resistance of the screw

Parameter / Size			VP C φ 8		VP C φ 10	
			Galvanized steel	Stainless steel	Galvanized steel	Stainless steel
Characteristic tension resistance	$N_{Rk,s}$	[kN]	11.3	15.8	15.4	21.6
Partial safety factor	γ_{Ms}	-	1.5			
Characteristic shear resistance	$V_{Rk,s}$	[kN]	5.6	7.9	7.7	10.8
Partial safety factor	γ_{Ms}	-	1.25			

Table 6 : Characteristic resistance for use in concrete³⁾

Plastic sleeve pull-out failure		VP C φ8		VP C φ10	
Temperature range		24/40 °C	50/80 °C	24/40 °C	50/80 °C
Characteristic tension resistance	$N_{Rk,p}$ [kN]	3.5	3.0	4.5	4.0
Partial safety factor	$\gamma_{Mc}^{1)}$	1.8			
Concrete cone failure and concrete edge failure for single anchor and anchor group					
Tension load ²⁾					
$N_{Rk,c} = 7,2 \cdot \sqrt{f_{ck,cube}} \cdot h_{ef}^{1,5} \cdot \frac{c}{c_{cr,N}}$					
with: $h_{ef}^{1,5} = \frac{N_{Rk,p}}{7,2 \cdot \sqrt{f_{ck,cube}}}$; $\frac{c}{c_{cr,N}} \leq 1$					
Shear load ²⁾					
$V_{Rk,c} = 0,45 \cdot \sqrt{d_{nom}} \cdot \left(\frac{h_{nom}}{d_{nom}}\right)^{0,2} \cdot \sqrt{f_{ck,cube}} \cdot c_1^{1,5} \cdot \left(\frac{c_2}{1,5c_1}\right)^{0,5} \cdot \left(\frac{h}{1,5c_1}\right)^{0,5}$					
with: $\left(\frac{c_2}{1,5c_1}\right)^{0,5} \leq 1$; $\left(\frac{h}{1,5c_1}\right)^{0,5} \leq 1$					
c_1 : edge distance closest to the edge in loading direction c_2 : edge distance perpendicular to direction 1 $f_{ck,cube}$: nominal characteristic concrete compression strength (based on cubes)					
Partial safety factor		$\gamma_{Mc}^{1)}=1,8$			

¹⁾ In absence of other national regulations.

²⁾ Design method according to ETAG 020, Annex C.

³⁾ Concrete strength $f_{ck} \geq 16 \text{ N/mm}^2$ (strength class C16/20 acc. to EN 206-1:2000-12)

Vorpa frame/multi-purpose anchor VP C

Characteristics resistance of the screw characteristic resistance in concrete (use category "a")

Annex 4

Table 7 : Displacements under tension load in concrete

Parameter / Size			VP C	VP C		
			φ8	φ10		
Service tension load concrete	N	[kN]	1.2	1.6		
			Displacements	δ_{N0}	[mm]	0.24
			$\delta_{N\infty}$	[mm]	0.48	0.58

Table 8 : Displacements under shear load in concrete

Parameter / Size			VP C	VP C		
			φ8	φ10		
Service shear load in concrete	V	[kN]	3.2	4.4		
			Displacements	δ_{V0}	[mm]	2.00
			$\delta_{V\infty}$	[mm]	3.00	2.50

Table 9 : Minimum thickness of the member, edge distance and spacing in concrete

Parameter / Size	Concrete class	
	VP C φ8	VP C φ10
	≥16/20	
Minimum thickness of the member	h_{min} [mm]	140
Characteristic edge distance	$c_{cr,N}^{1)}$ [mm]	105
Minimum allowable spacing and edge distance ¹⁾	s_{min} [mm]	90
	c_{min} [mm]	100

¹⁾ Intermediate value by linear interpolation

Scheme of edge distance and spacing in concrete

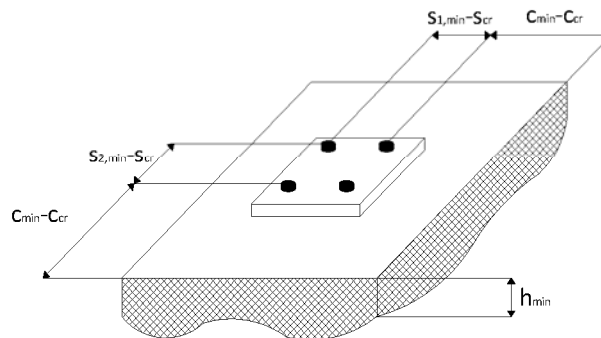

Vorpa frame/multi-purpose anchor VP C

Displacements in concrete and masonry, minimum thickness,
spacing and edge distance

Annex 5

Table 10 : Geometry and mechanical properties – Solid masonry type “A” (use category “b”)

Base material	Drill method	Bulk density class ρ	Minimum compressive strength f_b
description	-	[kg/dm ³]	[N/mm ²]
“A” - Mattone pieno 110x60x240 “Danesi”	Rotary + hammer	1.7	39.0

Table 11 : Geometry and mechanical properties – Solid masonry type “B” (use category “b”)

Base material	Drill method	Bulk density class ρ	Minimum compressive strength f_b
description	-	[kg/dm ³]	[N/mm ²]
“B” - Mattone pieno 250x120x55 “Terreal Italia”	Rotary + hammer	1.7	27.0

Table 12 : Geometry and mechanical properties – Solid masonry type “E” (use category “b”)

Base material	Drill method	Bulk density class ρ	Minimum compressive strength f_b
description	-	[kg/dm ³]	[N/mm ²]
“E” - Fior di tufo 370x370x110 “Cave riunite”	Rotary + hammer	2.4	7.5

Table 13 : Characteristic resistance in solid masonry

Parameter / Size		VP C	VP C
		$\phi 8$	$\phi 10$
Masonry type “A”			
Characteristic resistance F_{rk} ¹⁾	[kN]	3.0	2.0
Masonry type “B”			
Characteristic resistance F_{rk} ¹⁾	[kN]	4.0	5.0
Masonry type “E”			
Characteristic resistance F_{rk} ¹⁾	[kN]	-	0.3

¹⁾ Characteristic resistance F_{rk} for tension, shear or combined tension and shear loading, is valid for single plastic anchor or for a group of two or four plastic anchors with spacing equal or larger than the minimum spacing s_{min} according to Annex 10 and 11. The specific conditions for the design method have to be considered according to chapter 4.2.5 of the ETA

Vorpa frame/multi-purpose anchor VP C

Solid masonry: geometry, mechanical properties and characteristic resistance

Annex 6

Table 14 : Displacements under tension load in solid masonry – type “A”

Parameter / Size			VP C Ø8	VP C Ø10
Service tension load in solid masonry	N	[kN]	0.9	0.6
Displacements	δ_{N0}	[mm]	0.04	0.06
	$\delta_{N\infty}$	[mm]	0.08	0.12

Table 15 : Displacements under tension load in solid masonry – type “B”

Parameter / Size			VP C Ø8	VP C Ø10
Service tension load in solid masonry	N	[kN]	1.1	1.4
Displacements	δ_{N0}	[mm]	0.25	0.67
	$\delta_{N\infty}$	[mm]	0.50	1.34

Table 16 : Displacements under tension load in solid masonry – type “E”

Parameter / Size			VP C Ø10
Service tension load in solid masonry	N	[kN]	0.09
Displacements	δ_{N0}	[mm]	0.01
	$\delta_{N\infty}$	[mm]	0.02

Table 17 : Displacements under shear load in solid masonry

Parameter / Size			VP C Ø8	VP C Ø10
Service shear load in solid masonry	V	[kN]	3.2	4.4
Displacements	δ_{V0}	[mm]	2.67	3.67
	$\delta_{V\infty}$	[mm]	4.00	5.50

Vorpa frame/multi-purpose anchor VP C

Solid masonry: service loads and displacements

Annex 7

Table 18 : Geometry and mechanical properties – masonry type “C” (use category “c”)

Base material	Drill method	Bulk density class ρ	Minimum compressive strength f_b
description	-	[kg/dm ³]	[N/mm ²]
Doppio doppio UNI 120x245x250 “Danesi” 	Rotary	0.9	13.0

Table 19 : Geometry and mechanical properties - masonry type “D” (use category “c”)

Base material	Drill method	Bulk density class ρ	Minimum compressive strength f_b
description	-	[kg/dm ³]	[N/mm ²]
Forati 120x250x250 “Wienerberger” 	Rotary	0.6	2.0

Table 20 : Characteristic resistance in hollow masonry

Parameter / Size	VP C	
	$\phi 8$	$\phi 10$
Masonry type “C”		
Characteristic resistance $F_{Rk}^{1)}$	[kN]	-
		0.3
Masonry type “D”		
Characteristic resistance $F_{Rk}^{1)}$	[kN]	0.3
		-

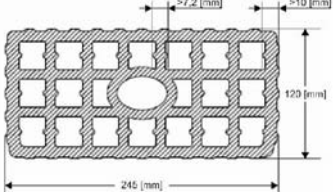
¹⁾ Characteristic resistance F_{Rk} for tension, shear or combined tension and shear loading, is valid for single plastic anchor or for a group of two or four plastic anchors with spacing equal or larger than the minimum spacing s_{min} according to Annex 10 and 11. The specific conditions for the design method have to be considered according to chapter 4.2.5 of the ETA

Vorpa frame/multi-purpose anchor VP C

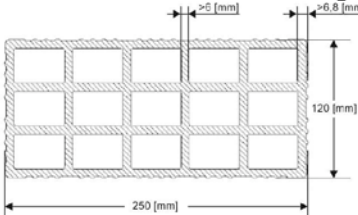
Hollow masonry: geometry, mechanical properties and characteristic resistance

Annex 8

Table 21 : Displacements under tension load in hollow masonry – type “C”

Parameter / Size			VP C φ10
Service tension load in hollow masonry	N	[kN]	0.09
Displacements	δ_{N0}	[mm]	0.12
	$\delta_{N\infty}$	[mm]	0.24

Table 22 : Displacements under tension load in hollow masonry – type “D”

Parameter / Size			VP C φ10
Service tension load in hollow masonry	N	[kN]	0.09
Displacements	δ_{N0}	[mm]	0.03
	$\delta_{N\infty}$	[mm]	0.06

Table 23 : Displacements under shear load in hollow masonry

Parameter / Size			VP C φ8	VP C φ10
Service shear load in hollow masonry	V	[kN]	3.2	4.4
Displacements	δ_{V0}	[mm]	6.40	8.80
	$\delta_{V\infty}$	[mm]	9.60	13.20

Vorpa frame/multi-purpose anchor VP C

Hollow masonry: service loads and displacements

Annex 9

Table 24 : Minimum distances and dimensions in solid masonry – Type “A”

Parameter / Size		VP C	VP C
		Ø8	Ø10
Minimum thickness of the member	h_{min} [mm]	110	
Single anchor			
Minimum edge distance	c_{min} [mm]	120	
Anchor Group			
Spacing perpendicular to free edge	$S_{1,min}$ [mm]	240	
Spacing parallel to free edge	$S_{2,min}$ [mm]	480	
Minimum edge distance	c_{min} [mm]	120	

Table 25 : Minimum distances and dimensions in solid masonry – Type “B”

Parameter / Size		VP C	VP C
		Ø8	Ø10
Minimum thickness of the member	h_{min} [mm]	120	
Single anchor			
Minimum edge distance	c_{min} [mm]	125	
Anchor Group			
Spacing perpendicular to free edge	$S_{1,min}$ [mm]	250	
Spacing parallel to free edge	$S_{2,min}$ [mm]	500	
Minimum edge distance	c_{min} [mm]	125	

Table 26 : Minimum distances and dimensions in solid masonry – Type “E”

Parameter / Size		VP C	VP C
		Ø8	Ø10
Minimum thickness of the member	h_{min} [mm]	370	
Single anchor			
Minimum edge distance	c_{min} [mm]	185	
Anchor Group			
Spacing perpendicular to free edge	$S_{1,min}$ [mm]	370	
Spacing parallel to free edge	$S_{2,min}$ [mm]	740	
Minimum edge distance	c_{min} [mm]	185	

Vorpa frame/multi-purpose anchor VP C

Annex 10

Spacing and edge distance in solid masonry

Table 27 : Minimum distances and dimensions in hollow masonry – Type “C”

Parameter / Size		VP C φ10
Minimum thickness of the member	h_{\min} [mm]	120
Single anchor		
Minimum edge distance	c_{\min} [mm]	125
Anchor Group		
Spacing perpendicular to free edge	$S_{1,\min}$ [mm]	250
Spacing parallel to free edge	$S_{2,\min}$ [mm]	500
Minimum edge distance	c_{\min} [mm]	125

Table 28 : Minimum distances and dimensions in hollow masonry – Type “D”

Parameter / Size		VP C φ8
Minimum thickness of the member	h_{\min} [mm]	120
Single anchor		
Minimum edge distance	c_{\min} [mm]	125
Anchor Group		
Spacing perpendicular to free edge	$S_{1,\min}$ [mm]	250
Spacing parallel to free edge	$S_{2,\min}$ [mm]	500
Minimum edge distance	c_{\min} [mm]	75

Vorpa frame/multi-purpose anchor VP C

Annex 11

Spacing and edge distance in hollow masonry