

Approval body for construction products
and types of construction

Bautechnisches Prüfamt

An institution established by the Federal and
Laender Governments



European Technical Assessment

ETA-10/0114
of 3 December 2014

General Part

Technical Assessment Body issuing the
European Technical Assessment:

Deutsches Institut für Bautechnik

Trade name of the construction product

TOGE Concrete screw TSM 5 and TSM 6

Product family
to which the construction product belongs

Concrete screw size 5 and 6 for multiple use for non-
structural applications in concrete and in prestressed
hollow core slabs

Manufacturer

TOGE Dübel GmbH & Co. KG
Illesheimer Straße 10
90431 Nürnberg
DEUTSCHLAND

Manufacturing plant

TOGE Dübel GmbH & Co. KG

This European Technical Assessment
contains

14 pages including 3 annexes which form an integral part
of this assessment

This European Technical Assessment is
issued in accordance with Regulation (EU)
No 305/2011, on the basis of

Guideline for European technical approval of "Metal
anchors for use in concrete", ETAG 001 Part 6: "Anchors
for multiple use for non-structural applications", Edition
August 2010,
used as European Assessment Document (EAD)
according to Article 66 Paragraph 3 of Regulation (EU)
No 305/2011.

The European Technical Assessment is issued by the Technical Assessment Body in its official language. Translations of this European Technical Assessment in other languages shall fully correspond to the original issued document and shall be identified as such.

Communication of this European Technical Assessment, including transmission by electronic means, shall be in full. However, partial reproduction may only be made with the written consent of the issuing Technical Assessment Body. Any partial reproduction has to be identified as such.

This European Technical Assessment may be withdrawn by the issuing Technical Assessment Body, in particular pursuant to information by the Commission according to Article 25 Paragraph 3 of Regulation (EU) No 305/2011.

Specific Part

1 Technical description of the product

The TOGE Concrete screw in size of 5 and 6 is an anchor made of zinc-plated steel respectively steel with zinc flake coating (TSM B, TSM BC) or made of stainless steel (TSM BS, TSM BSH). The anchor is screwed into a predrilled cylindrical drill hole. The special thread of the anchor cuts an internal thread into the member while setting. The anchorage is characterised by mechanical interlock in the special thread.

Product and product description is given in Annex A.

2 Specification of the intended use in accordance with the applicable European Assessment Document

The performances given in Section 3 are only valid if the anchor is used in compliance with the specifications and conditions given in Annex B.

The verifications and assessment methods on which this European Technical Assessment is based lead to the assumption of a working life of the anchor of at least 50 years. The indications given on the working life cannot be interpreted as a guarantee given by the producer, but are to be regarded only as a means for choosing the right products in relation to the expected economically reasonable working life of the works.

3 Performance of the product and references to the methods used for its assessment

3.1 Mechanical resistance and stability (BWR 1)

The essential characteristics regarding mechanical resistance and stability are included under the Basic Works Requirement Safety in use.

3.2 Safety in case of fire (BWR 2)

Essential characteristic	Performance
Reaction to fire	Anchorage satisfy requirements for Class A1
Resistance to fire	See Annex C 2

3.3 Hygiene, health and the environment (BWR 3)

Not applicable.

3.4 Safety in use (BWR 4)

Essential characteristic	Performance
Characteristic resistance for tension and shear loads as well as bending moments in concrete	See Annex C 1 and C 2
Edge distances and spacing	See Annex C 1

3.5 Protection against noise (BWR 5)

Not applicable.

3.6 Energy economy and heat retention (BWR 6)

Not applicable.

3.7 Sustainable use of natural resources (BWR 7)

The sustainable use of natural resources was not investigated.

3.8 General aspects

The verification of durability is part of testing the essential characteristics. Durability is only ensured if the specifications of intended use according to Annex B are taken into account.

4 Assessment and verification of constancy of performance (AVCP) system applied, with reference to its legal base

According to Decision of the Commission of 17 February 1997 (97/161/EC) (OJ L 062 of 04.03.97 p. 41-42), the system of assessment and verification of constancy of performance (see Annex V and Article 65 Paragraph 2 to Regulation (EU) No 305/2011) given in the following table applies.

Product	Intended use(s)	Level or class	System
Metal anchors for use in concrete (light-duty type)	For use in redundant systems for fixing and/or supporting to concrete elements such as lightweight suspended ceilings, as well as installations	—	2+

5 Technical details necessary for the implementation of the AVCP system, as provided for in the applicable European Assessment Document

Technical details necessary for the implementation of the AVCP system are laid down in the control plan deposited at Deutsches Institut für Bautechnik.

Issued in Berlin on 3 December 2014 by Deutsches Institut für Bautechnik

Uwe Bender
Head of Department

beglaubigt:
Tempel

product and installed condition

Toge concrete screw TSM 5 and TSM 6

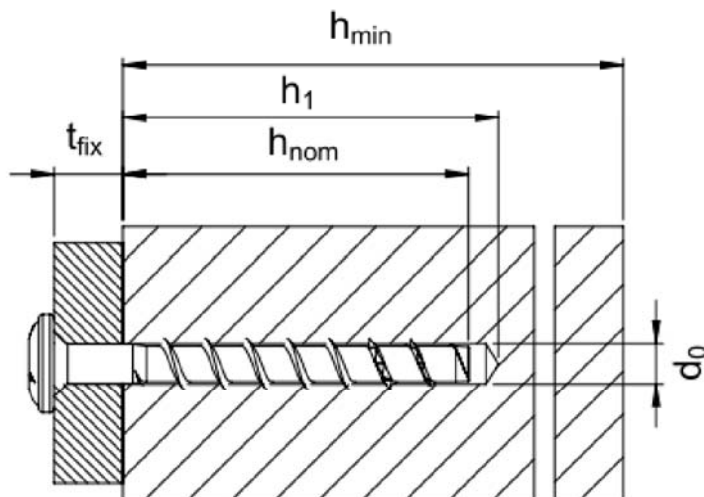
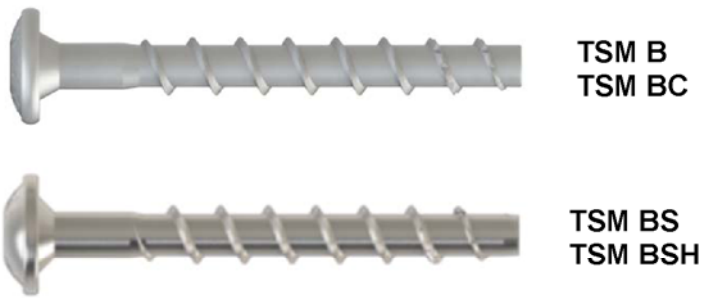

- d_0 = nominal drill bit diameter
- h_{nom} = nominal anchorage depth
- h_1 = depth of the drill hole
- h_{min} = minimum thickness of member
- t_{fix} = thickness of fixture

TOGE concrete screw TSM B, BC, BS, BSH

Product description

Installed condition

Annex A 1

installed condition in precast prestressed hollow core slabs

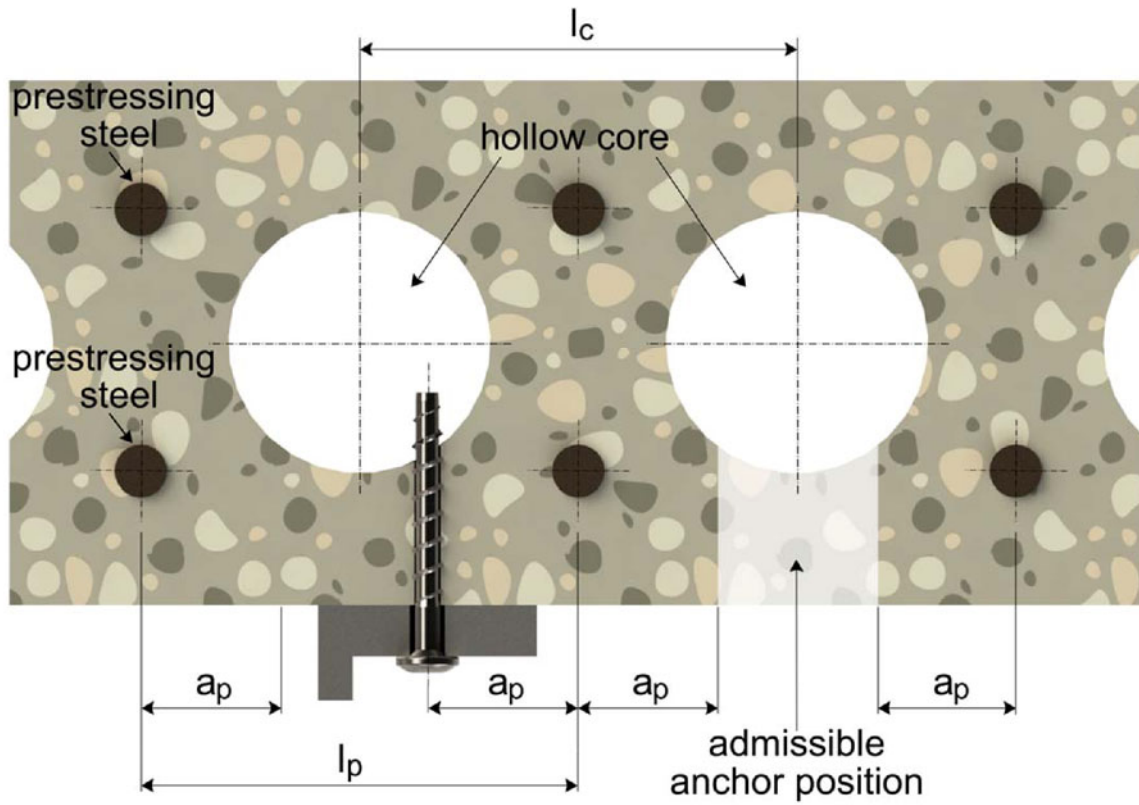

TOGE concrete screw TSM B, BC, BS, BSH

















Product description

Installed condition

Annex A 2

Table A 1: materials and variants

part	name	Material		
1, 2, 3, 4, 5, 6, 7, 8	Screw anchor	TSM B, BC	Steel EN 10263-4 galvanized acc. to EN ISO 4042 or zinc flake coating acc. to EN ISO 10683 ($\geq 5\mu\text{m}$)	
		TSM BS	1.4401, 1.4404, 1.4571, 1.4578	
		TSM BSH	1.4529	
		nominal characteristic steel yield strength	f_{yk} [N/mm ²]	600
		nominal characteristic steel ultimate strength	f_{uk} [N/mm ²]	700

		1)	Anchor version with connection thread
		2)	Anchor version with washer, hexagon head and TORX
		3)	Anchor version with washer, hexagon head and
		4)	Anchor version with hexagon head
		5)	Anchor version with countersunk head
		6)	Anchor version with pan head
		7)	Anchor version with countersunk head and connection thread
		8)	Anchor version with hexagon head and connection thread

TOGE concrete screw TSM B, BC, BS, BSH

Product description
Material and screw types

Annex A 3

Table A 2: dimensions and markings

Anchor size			TSM 5	TSM 6
Length of the anchor	$L \leq$	[mm]	200	
Diameter of shaft	d_k	[mm]	4,2	5,2
Diameter of thread	d_s	[mm]	6,5	7,5

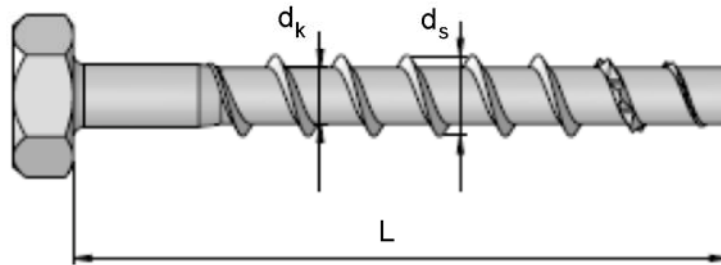

Marking:

Anchor type: TSM B, TSM BC, TSM BS, TSM BSH
Anchor size: 6
Length of the anchor: 60



Marking "k" or "x" for anchors with connection thread
and $h_{nom} = 35$ mm

TOGE concrete screw TSM B, BC, BS, BSH

Product descriptions
Dimensions and markings

Annex A 4

Intended use

Anchorage subject to:

- static and quasi static loads
- Used only for multiple use for non structural application according to ETAG 001, Part 6
- Used for anchorages with requirements related to resistance of fire
- Used for anchorages in prestressed hollow core slabs

Base materials:

- reinforced and unreinforced concrete according to EN 206-1:2000
- strength classes C20/25 to C50/60 according to EN 206-1:2000
- cracked and non-cracked concrete

Use conditions (Environmental conditions):

- The anchor may only be used in dry internal conditions: All screw types
- Structural subject to external atmospheric exposure (including industrial and marine environment) and to permanently damp internal condition if no particular aggressive conditions exists: screw types made of stainless steel with marking BS
- Structural subject to external atmospheric exposure (including industrial and marine environment) and to permanently damp internal condition if particular aggressive conditions exists: screw types made of stainless steel with marking BSH

Design:

- Anchorages are designed under the responsibility of an engineer experienced in anchorages and concrete work.
- Verifiable calculation notes and drawings are prepared taking account of the loads to be anchored. The position of the anchor is indicated on the design drawings (e.g. position of the anchor relative to reinforcement or to supports, etc.).
- Anchorages under static or quasi-static actions are designed for design method A in accordance with:
 - ETAG 001, Annex C, Edition August 2010
 - CEN/TS 1992-4:2009.
- Anchorages under fire exposure are designed in accordance with:
 - EOTA Technical Report TR 020, Edition May 2004 or
 - CEN/TS 1992-4:2009, Annex D (It must be ensured that local spalling of the concrete cover does not occur).

Installation:

- Hammer drilling only.
- Anchor installation carried out by appropriately qualified personal and under the supervision of the person responsible for technical matters of the site.
- After installation further turning of the anchor is not possible. The head of the anchor is supported on the fixture and is not damaged.

TOGE concrete screw TSM B, BC, BS, BSH

Intended use

Specifications

Annex B 1

Table B 1: Installation parameters

Anchorsize			TSM 5	TSM 6	
Nominal embedment depth			$h_{nom} = 35 \text{ mm}$	$h_{nom} = 35 \text{ mm}$	$h_{nom} = 55 \text{ mm}$
nominal drill bit diameter	d_0	[mm]	5	6	
cutting diameter of drill bit	$d_{cut} \leq$	[mm]	5,40	6,40	
depth of drill hole	$h_1 \geq$	[mm]	40	40	60
Nominal embedment depth	$h_{nom} \geq$	[mm]	35	35	55
diameter of clearing hole in the fixture	$d_f \geq$	[mm]	7	8	

Table B 2: Minimum thickness of member, minimum edge distance and minimum spacing

Anchorsize			TSM 5	TSM 6	
Nominal embedment depth			$h_{nom} = 35 \text{ mm}$	$h_{nom} = 35 \text{ mm}$	$h_{nom} = 55 \text{ mm}$
minimum thickness of member	h_{min}	[mm]	80	80	100
minimum edge distance	c_{min}	[mm]	35	35	40
minimum spacing	s_{min}	[mm]	35	35	40

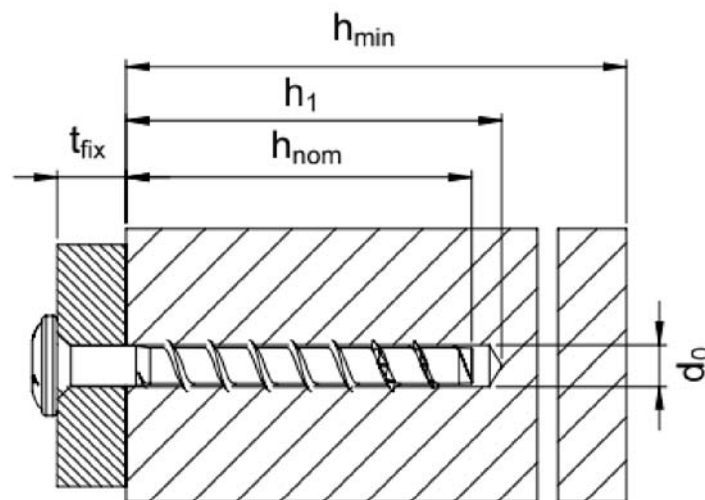

TOGE concrete screw TSM B, BC, BS, BSH

Intended use

Installation parameters

Annex B 2

Installation parameters for anchorages in precast prestressed hollow core slabs

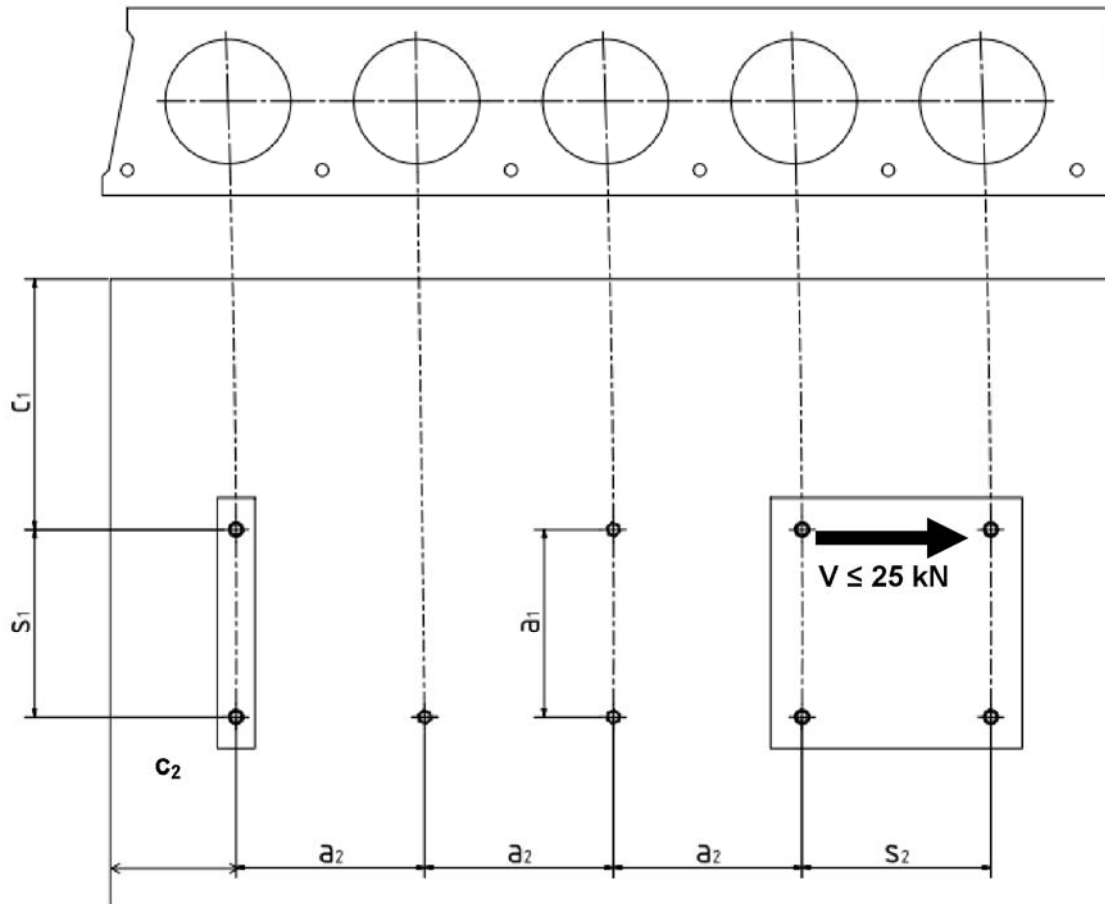

c_1, c_2 edge distance
 s_1, s_2 anchor spacing
 a_1, a_2 distance between anchor groups

Minimum edge distance $c_{\min} \geq 100 \text{ mm}$

Minimum anchor spacing $s_{\min} \geq 100 \text{ mm}$

Minimum distance between anchor groups $a_{\min} \geq 100 \text{ mm}$

The maximum shear load of an anchor groups is restricted to max. $V = 25 \text{ kN}$

TOGE concrete screw TSM B, BC, BS, BSH

Intended use

Installation parameters for anchorages in precast prestressed hollow slabs

Annex B 3

Installation instructions

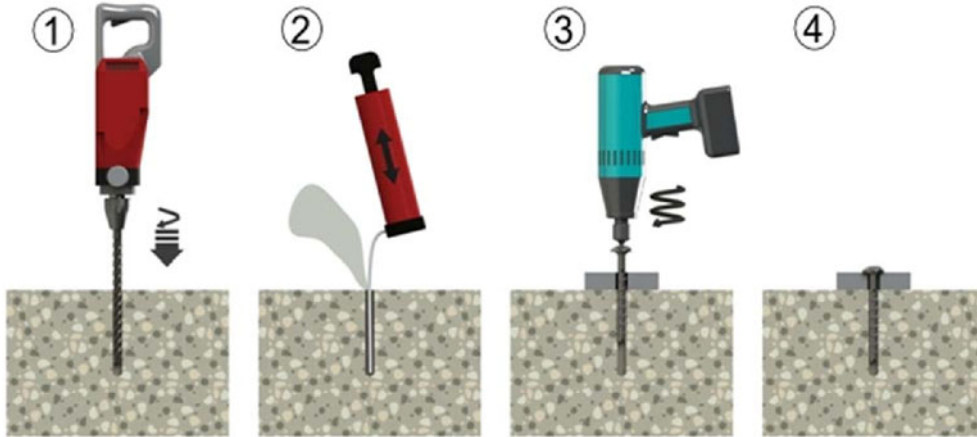

Installation instructions for anchorages in prestressed hollow slabs

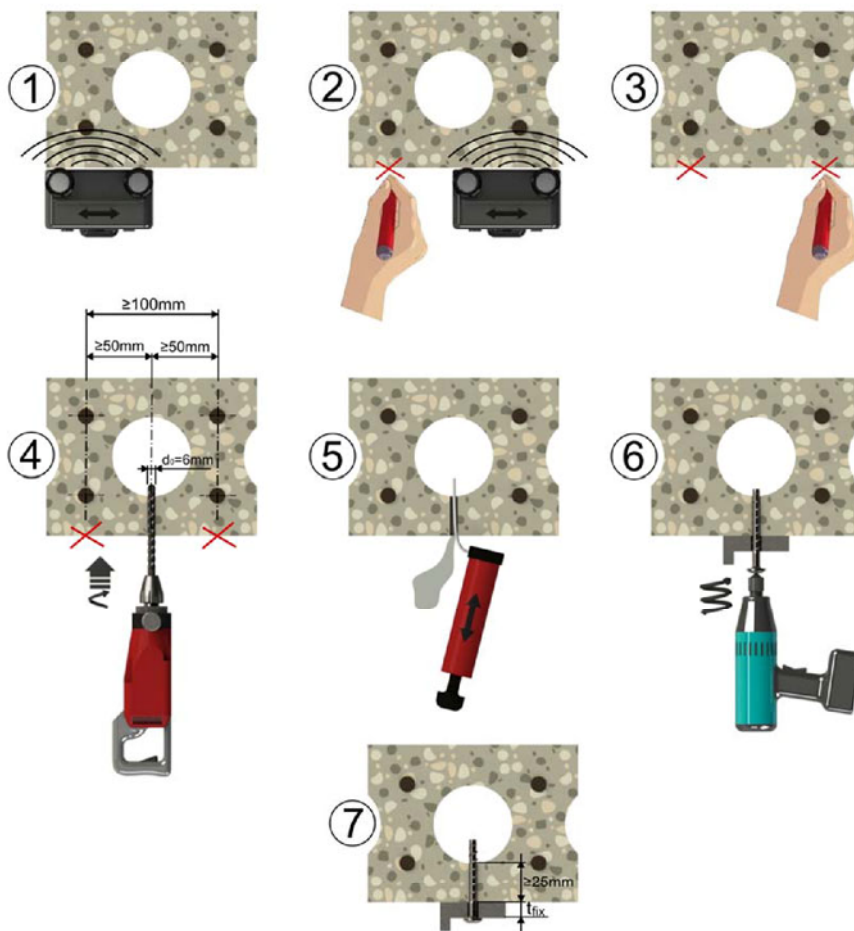

TOGE concrete screw TSM B, BC, BS, BSH

Intended use

Installation instructions

Annex B 4

**Table C 1: Characteristic values for design method A according to ETAG 001, Annex C
or CEN TS 1992-4**

Anchorsize			TSM 5	TSM 6	
Nominal embedment depth			$h_{nom} = 35 \text{ mm}$	$h_{nom} = 35 \text{ mm}$	$h_{nom} = 55 \text{ mm}$
steel failure for tension- and shear load					
characteristic load	$N_{RK,s}$	[kN]	8,7	13,7	
	$V_{RK,s}$	[kN]	4,4	7,0	
	$M^0_{RK,s}$	[Nm]	5,3	10,0	
Pull-out failure					
characteristic tension load in concrete C20/25	$N_{RK,p}$	[kN]	1,5	1,5	7,5
increasing factor concrete for $N_{RK,p}$	Ψ_C	C30/37	1,22		
		C40/50	1,41		
		C50/60	1,55		
concrete cone and splitting failure					
effective anchorage depth	h_{ef}	[mm]	27	27	44
factor for	cracked	$k_{cr}^{1)}$	7,2		
	non cracked	$k_{ucr}^{1)}$	10,1		
concrete cone failure	spacing	$s_{cr,N}$	$3 \times h_{ef}$		
	edge distance	$c_{cr,N}$	$1,5 \times h_{ef}$		
splitting failure	spacing	$s_{cr,Sp}$	120	120	160
	edge distance	$c_{cr,Sp}$	60	60	80
installation safety factor	$\gamma_2^{1)} = \gamma_{inst}^{2)}$	[-]	1,2 ²⁾	1,2 ²⁾	1,0 ²⁾
concrete pry out failure (pry-out)					
k-Factor	$k^{1)} = k_3^{2)}$	[-]	1,0		
concrete edge failure					
effective length of anchor	$l_f = h_{ef}$	[mm]	27	27	44
outside diameter of anchor	d_{nom}	[-]	5	6	

¹⁾ Parameter relevant only for design according to CEN/TS 1992-4:2009

²⁾ Parameter relevant only for design according ETAG 001 Annex C

TOGE concrete screw TSM B, BC, BS, BSH

Performances

Characteristic values for design method A

Annex C 1

**Table C2: Characteristic values of resistance in precast prestressed hollow core slabs
C30/37 to C50/60**

Anchorsize			TSM 6		
Bottom flange thickness	d_b	[mm]	≥ 25	≥ 30	≥ 35
Characteristic resistance	F_{Rk}^0	[kN]	1	2	3
installation safety factor	$\gamma_2^{1)} = \gamma_{inst}^{2)}$	[mm]	1,2		

¹⁾ Parameter relevant only for design according to CEN/TS 1992-4:2009

²⁾ Parameter relevant only for design according ETAG 001 Annex C

Table C 3: Characteristic values of resistance to fire exposure

Anchorsize				TSM 6		
Nominal embedment depth				$h_{nom} = 35 \text{ mm}$	$h_{nom} = 55 \text{ mm}$	
				B, BC, BS, BSH	B, BC	BS, BSH
fire resistance class						
R 30	characteristic resistance	$F_{Rk,fi30}$	[kN]	0,38	0,9	1,2
R 60	characteristic resistance	$F_{Rk,fi60}$	[kN]	0,38	0,8	1,2
R 90	characteristic resistance	$F_{Rk,fi90}$	[kN]	0,38	0,6	1,2
R 120	characteristic resistance	$F_{Rk,fi120}$	[kN]	0,30	0,4	0,8
R 30 bis R 120	spacing	$s_{cr,fi}$	[mm]	120		
	edge distance	$c_{cr,fi}$		60		

TOGE concrete screw TSM B, BC, BS, BSH

Performances

Characteristic values for anchorages in precast prestressed hollow core slabs and characteristic values of resistance to fire exposure

Annex C 2