

Approval body for construction products
and types of construction

Bautechnisches Prüfamt

An institution established by the Federal and
Laender Governments



European Technical Assessment

ETA-11/0492
of 26 May 2014

General Part

Technical Assessment Body issuing the
European Technical Assessment:

Deutsches Institut für Bautechnik

Trade name of the construction product

Injection System Hilti HIT-HY 200-A for rebar connection

Product family
to which the construction product belongs

Post-installed rebar connection with Hilti injection mortar
HIT-HY 200-A

Manufacturer

Hilti Aktiengesellschaft
9494 SCHAAN
FÜRSTENTUM LIECHTENSTEIN

Manufacturing plant

Hilti Werke

This European Technical Assessment
contains

22 pages including 3 annexes which form an integral part
of this assessment

This European Technical Assessment is
issued in accordance with Regulation (EU)
No 305/2011, on the basis of

Guideline for European technical approval of "Metal
anchors for use in concrete", ETAG 001 Part 5: "Bonded
anchors", April 2013,
used as European Assessment Document (EAD)
according to Article 66 Paragraph 3 of Regulation (EU)
No 305/2011.

The European Technical Assessment is issued by the Technical Assessment Body in its official language. Translations of this European Technical Assessment in other languages shall fully correspond to the original issued document and shall be identified as such.

Communication of this European Technical Assessment, including transmission by electronic means, shall be in full. However, partial reproduction may only be made with the written consent of the issuing Technical Assessment Body. Any partial reproduction has to be identified as such.

This European Technical Assessment may be withdrawn by the issuing Technical Assessment Body, in particular pursuant to information by the Commission according to Article 25 Paragraph 3 of Regulation (EU) No 305/2011.

Specific Part

1 Technical description of the product

The subject of this European technical assessment is the post-installed connection, by anchoring or overlap connection joint, of reinforcing bars (rebars) in existing structures made of normal weight concrete, using the injection mortar Hilti HIT-RE 500 in accordance with the regulations for reinforced concrete construction.

Reinforcing bars made of steel with a diameter ϕ from 8 to 40 mm according to Annex A 4 or the Hilti tension anchor HZA-R sizes M12, M16, M20 and M24 according to Annex A 5 and injection mortar Hilti HIT-HY 200-A are used for rebar connections. The steel element is placed into a drilled hole filled with injection mortar and is anchored via the bond between embedded element, injection mortar and concrete.

The product description is given in Annex A.

2 Specification of the intended use in accordance with the applicable European Assessment Document

The performances given in Section 3 are only valid if the rebar connection is used in compliance with the specifications and conditions given in Annex B.

The verifications and assessment methods on which this European Technical Assessment is based lead to the assumption of a working life of the rebar connection of at least 50 years. The indications given on the working life cannot be interpreted as a guarantee given by the producer, but are to be regarded only as a means for choosing the right products in relation to the expected economically reasonable working life of the works.

3 Performance of the product and references to the methods used for its assessment

3.1 Mechanical resistance and stability (BWR 1)

Essential characteristic	Performance
Design values of the ultimate bond resistance	See Annex C 1

3.2 Safety in case of fire (BWR 2)

Essential characteristic	Performance
Reaction to fire	Anchorage satisfy requirements for Class A1
Resistance to fire	No performance determined (NPD)

3.3 Hygiene, health and the environment (BWR 3)

Regarding dangerous substances there may be requirements (e.g. transposed European legislation and national laws, regulations and administrative provisions) applicable to the products falling within the scope of this European Technical Assessment. In order to meet the provisions of Regulation (EU) No 305/2011, these requirements need also to be complied with, when and where they apply.

3.4 Safety in use (BWR 4)

The essential characteristics regarding Safety in use are included under the Basic Works Requirement Mechanical resistance and stability.

3.5 Protection against noise (BWR 5)

Not applicable.

3.6 Energy economy and heat retention (BWR 6)

Not applicable.

3.7 Sustainable use of natural resources (BWR 7)

The sustainable use of natural resources was not investigated.

3.8 General aspects

The verification of durability is part of testing the essential characteristics. Durability is only ensured if the specifications of intended use according to Annex B are taken into account.

4 Assessment and verification of constancy of performance (AVCP) system applied, with reference to its legal base

According to Decision of the Commission of 24 June 1996 (96/582/EC) (OJ L 254 of 08.10.96 p. 62-65), the system of assessment and verification of constancy of performance (see Annex V and Article 65 Paragraph 2 to Regulation (EU) No 305/2011) given in the following table applies.

Product	Intended use	Level or class	System
Metal anchors for use in concrete (heavy-duty type)	For fixing and/or supporting concrete structural elements or heavy units such as cladding and suspended ceilings	—	1

5 Technical details necessary for the implementation of the AVCP system, as provided for in the applicable European Assessment Document

Technical details necessary for the implementation of the AVCP system are laid down in the control plan deposited at Deutsches Institut für Bautechnik.

Issued in Berlin on 26 May 2014 by Deutsches Institut für Bautechnik

Dr.-Ing- Karsten Kathage
Vice President

Beglaubigt:
Baderschneider

Installation post installed rebar

Figure A1: Overlap joint with existing reinforcement for rebar connections of slabs and beams

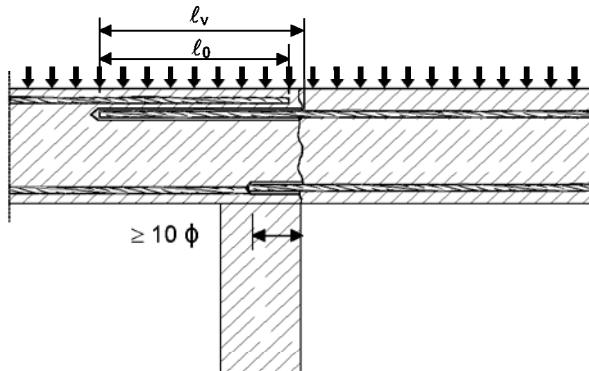

Figure A2: Overlap joint with existing reinforcement at a foundation of a column or wall where the rebars are stressed in tension

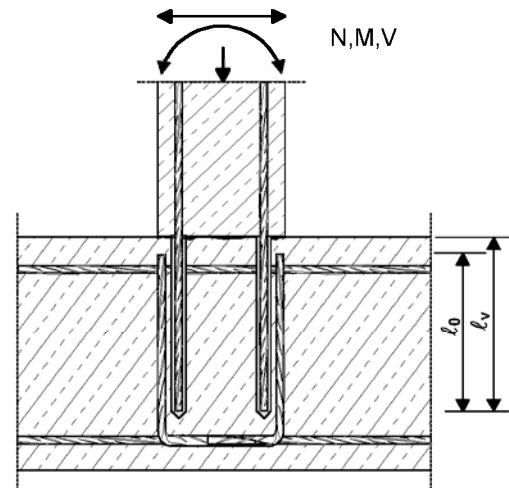

Figure A3: End anchoring of slabs or beams

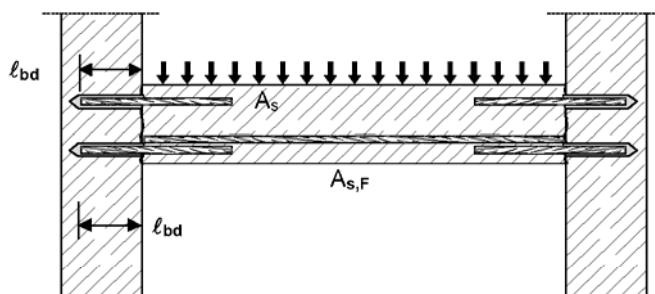

Figure A4: Rebar connection for components stressed primarily in compression.

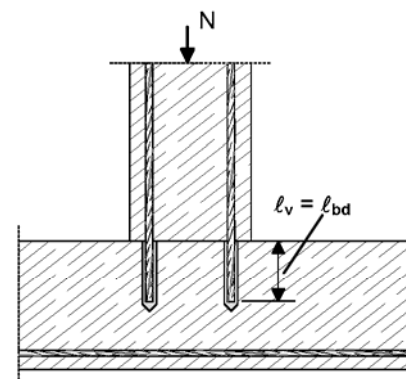
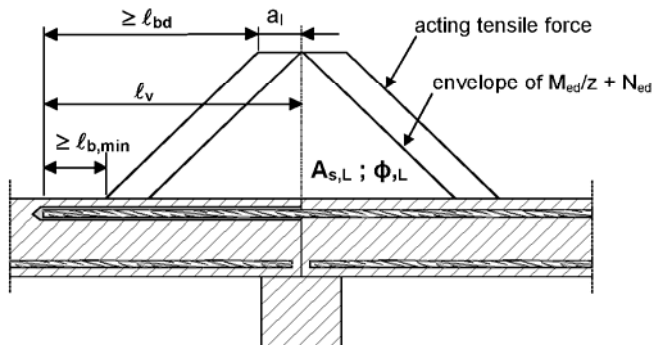

Figure A5: Anchoring of reinforcement to cover the enveloped line of acting tensile force in the bending member



Note to Figure A1 to A5:

In the Figures no transverse reinforcement is plotted, the transverse reinforcement shall comply with EN 1992-1-1:2004+AC:2010.

Preparing of joints according to Annex B 2

Injection system Hilti HIT-HY 200-A for rebar connection

Product description

Installed condition and examples of use for post installed rebars

Annex A 1

Installation Hilti tension anchor HZA-R

Figure A6: Overlap joint of a column stressed in bending to a foundation

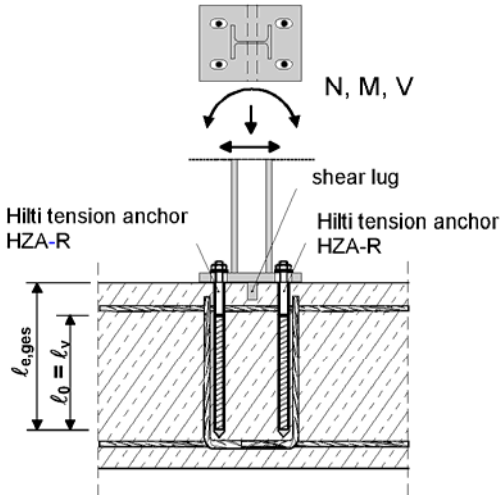

Figure A7: Overlap joint for the anchorage of barrier posts

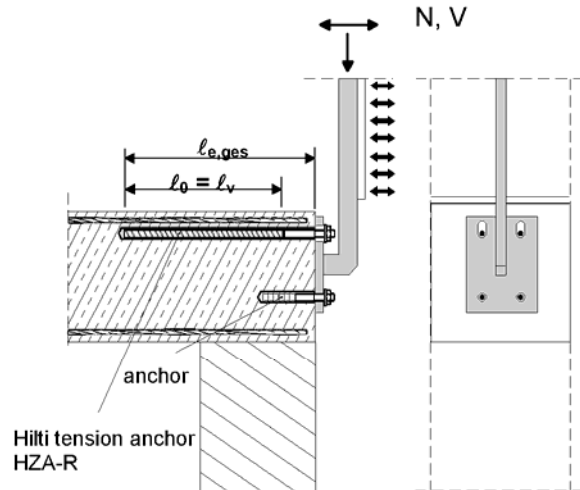
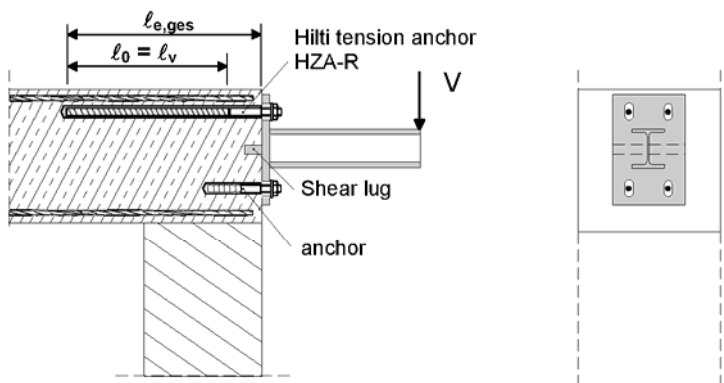

Figure A8: Overlap joint for the anchorage of cantilever members



Note to Figure A6 to A8:

In the Figures no transverse reinforcement is plotted, the transverse reinforcement shall comply with EN 1992-1-1:2004+AC:2010.

Electronic copy of the ETA by DIBt: ETA-11/0492

Injection system Hilti HIT-HY 200-A for rebar connection

Product description

Installed condition and examples of use for Hilti tension anchor HZA-R

Annex A 2

**Injection mortar Hilti HIT-HY 200-A: Hybrid system with aggregate
330 ml and 500 ml**



Static mixer Hilti HIT-RE-M



Reinforcing bar (rebar): ϕ 8 mm to 32 mm



Hilti tension anchor HZA-R: M12, M16, M20, M24



<p>Injection system Hilti HIT-HY 200-A for rebar connection</p>	<p>Annex A 3</p>
<p>Product description Injection mortar / Static mixer / Rebar / Hilti tension anchor HZA-R</p>	

Figure A6: Reinforcing bar



- Minimum value of related rip area $f_{R,min}$ according to EN 1992-1-1:2004+AC:2010
- The maximum outer rebar diameter over the ribs shall be:
Nominal diameter of the rib $\phi + 2 \cdot h$ ($h \leq 0,07 \cdot \phi$)
(ϕ : Nominal diameter of the bar; h : Rip height of the bar)

Table A1: Materials

Designation	Rebar
Rebar EN 1992-1-1:2004+AC:2010, Annex C	Bars and de-coiled rods Class B or C f_{yk} and k according to NDP or NCL of EN 1992-1-1/NA:2013 $f_{uk} = f_{tk} = k \cdot f_{yk}$

Injection system Hilti HIT-HY 200-A for rebar connection	Annex A 4
Product description Specifications reinforcing bar	

Figure A7: Hilti tension anchor HZA-R

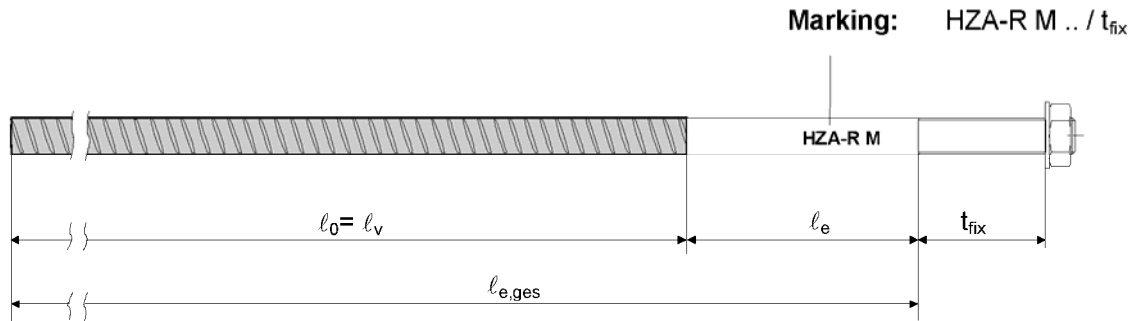

Table A2: Hilti tension anchor HZA-R, materials

Part	Designation	Material HZA-R			
		M12	M16	M20	M24
1	Reinforcement bar	Carbon steel			
	Characteristic yield strength $f_{k0,2}$ [N/mm ²]	500	500	500	460
2	Round steel smooth with thread	stainless steel, 1.4404 and 1.4571, 1.4362, EN 10088-1:2005			
3	Washer	stainless steel 1.4401, 1.4404, 1.4578, 1.4571, 1.4439 and 1.4362, EN 10088-1:2005			
4	Hexagon nut	Strength class 70 EN ISO 3506-2 stainless steel 1.4401, 1.4404, 1.4578, 1.4571, 1.4439 and 1.4362, EN 10088-1:2005			

Table A3: Hilti tension anchor HZA-R, dimensions

HZA-R			M12	M16	M20	M24
Diameter of reinforcement bar	ϕ	[mm]	12	16	20	25
Width across nut flats	SW	[mm]	19	24	30	36
Effective embedment depth	$l_v \leq 1)$	[mm]	800	1300	1300	1300
Length of smooth shaft	$l_e \geq$	[mm]	100			
Maximum torque moment	T_{max}	[Nm]	40	80	150	200
Minimum thickness of fixture	t_{fix}	[mm]	5	5	5	5
Maximum thickness of fixture	t_{fix}	[mm]	200	200	200	400

¹⁾ May be shortened according to static calculation

Injection system Hilti HIT-HY 200-A for rebar connection

Product description
Specifications Hilti tension anchor HZA-R

Annex A 5

Specifications of intended use

Anchorage subject to:

- Static and quasi-static loads.

Base materials:

- Reinforced or unreinforced normal weight concrete according to EN 206-1:2000,
- Strength classes C12/15 to C50/60 according to EN 206-1:2000,
- Maximum chloride concrete of 0,40 % (CL 0.40) related to the cement content according to EN 206-1:2000,
- Non-carbonated concrete.

Note: In case of a carbonated surface of the existing concrete structure the carbonated layer shall be removed in the area of the post-installed rebar connection with a diameter of $d_s + 60$ mm prior to the installation of the new rebar. The depth of concrete to be removed shall correspond to at least the minimum concrete cover in accordance with EN 1992-1-1:2004+AC:2010.

The foregoing may be neglected if building components are new and not carbonated and if building components are in dry conditions.

Temperature Range:

- - 40 °C to +80 °C (max. short term temperature +80 °C and max long term temperature +50 °C).

Use conditions (Environmental conditions) for Hilti Tension anchor HZA-R:

- Structures subject to dry internal conditions.
 - Structures subject to external atmospheric exposure (including industrial and marine environment) and to permanently damp internal condition, if no particular aggressive conditions exist.
- Note: Particular aggressive conditions are e.g. permanent, alternating immersion in seawater or the splash zone of seawater, chloride atmosphere of indoor swimming pools or atmosphere with extreme chemical pollution (e.g. in desulphurization plants or road tunnels where de-icing materials are used).

Design:

- Anchorages are designed under the responsibility of an engineer experienced in anchorages and concrete work.
- Verifiable calculation notes and drawings are prepared taking account of the forces to be transmitted.
- Design according to EN 1992-1-1:2004+AC:2010 and Annexes B 2 and B 3
- The actual position of the reinforcement in the existing structure shall be determined on the basis of the construction documentation and taken into account when designing.

Installation:

- Dry or wet concrete,
- It must not be installed in flooded holes,
- Hole drilling by hammer drill (HD) and hammer drill with hollow drill bit (HDB) or compressed air drill mode (CA).
- The installation of post-installed rebar respectively Hilti tension anchor HZA-R shall be done only by suitable trained installer and under supervision on site; the conditions under which an installer may be considered as suitable trained and the conditions for supervision on site are up to the Member States in which the installation is done.
- Check the position of the existing rebars (if the position of existing rebars is not known, it shall be determined using a rebar detector suitable for this purpose as well as on the basis of the construction documentation and then marked on the building component for the overlap joint).

Injection system Hilti HIT-HY 200-A for rebar connection	Annex B 1
Intended use Specifications	

Figure B1: General construction rules for post-installed rebars

- Only tension forces in the axis of the rebar may be transmitted.
- The transfer of shear forces between new concrete and existing structure shall be designed additionally according to EN 1992-1-1:2004+AC:2010.
- The joints for concreting must be roughened to at least such an extent that aggregate protrude.

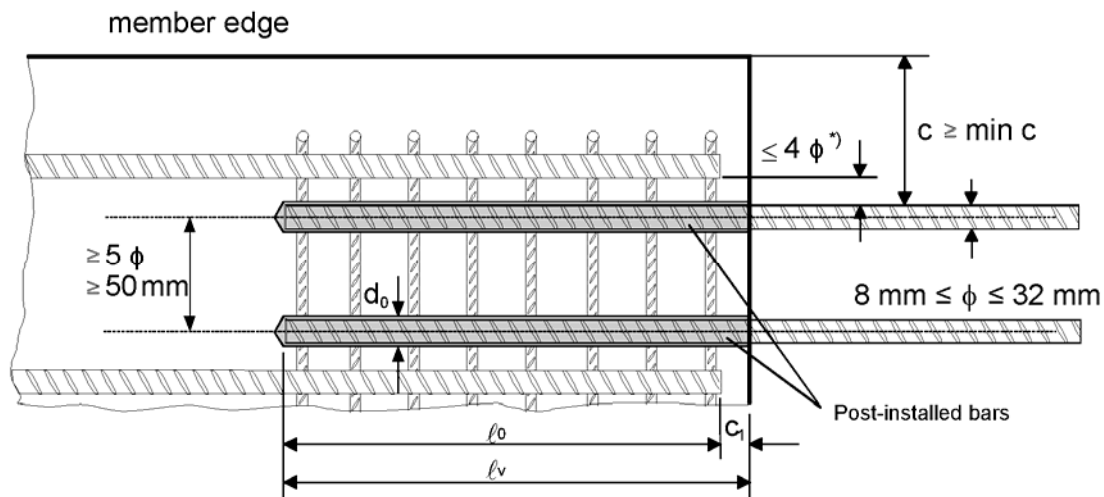

^{*)} If the clear distance between lapped bars exceeds 4ϕ , then the lap length shall be increased by the difference between the clear bar distance and 4ϕ .

- c concrete cover of post-installed rebar
- c_1 concrete cover at end-face of existing rebar
- min c minimum concrete cover according to Table B1 and to EN 1992-1-1:2004+AC:2010, Section 4.4.1.2
- ϕ diameter of reinforcement bar
- ℓ_0 lap length, according to EN 1992-1-1:2004+AC:2010, Section 8.7.3
- ℓ_v effective embedment depth, $\geq \ell_0 + c_1$
- d_0 nominal drill bit diameter, see Annex B 5

Injection system Hilti HIT-HY 200-A for rebar connection	Annex B 2
Intended use General construction rules for post-installed rebars	

Figure B2: General construction rules for Hilti tension anchor HZA-R

- The length of the bonded-in shaft made of stainless steel may not be accounted as anchorage.
- Only tension forces in the direction of the bar axis may be transmitted by the Hilti tension anchor HZA-R.
- The tension force must be transferred via an overlap joint to the reinforcement in the building part.
- The transmission of the shear load shall be ensured by appropriate additional measures, e.g. by shear lugs or by anchors with an European technical assessment.
- In the anchor plate, the holes for the tension anchor shall be executed as elongated holes with the axis in the direction of the shear force.

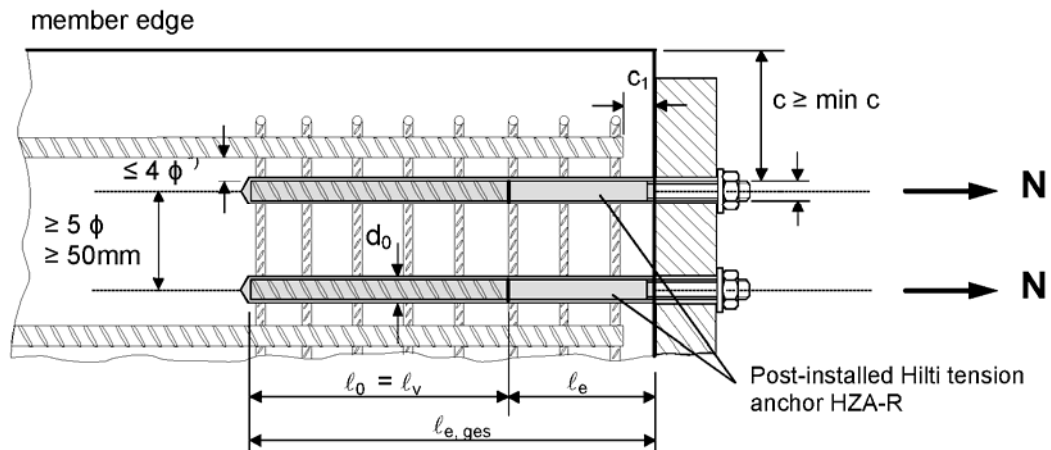

^{*)} If the clear distance between lapped bars exceeds $4d_s$, then the lap length shall be increased by the difference between the clear bar distance and $4d_s$.

- c concrete cover of Hilti tension anchor HZA-R
 c_1 concrete cover at end-face of existing rebar
 $\text{min } c$ minimum concrete cover according to Table B1 and to EN 1992-1-1:2004+AC:2010, Section 4.4.1.2
 ϕ diameter of reinforcement bar
 l_0 lap length, according to EN 1992-1-1:2004+AC:2010, Section 8.7.3
 l_v effective embedment depth, see Annex A 5
 l_e length of the smooth shaft or the bonded-in threaded part; $l_e \geq 100\text{mm}$, $l_e \geq c_1$
 $l_{e, ges}$ overall embedment depth; $\geq l_0 + l_e$
 d_0 nominal drill bit diameter, see Annex B 5

Electronic copy of the ETA by DIBt: ETA-11/0492

Injection system Hilti HIT-HY 200-A for rebar connection	Annex B 3
Intended use General construction rules for Hilti tension anchor HZA-R	

Table B1: Minimum concrete cover $\min c$ ¹⁾ of the post-installed rebar or Hilti tension anchor HZA-R depending on drilling method and drilling tolerance

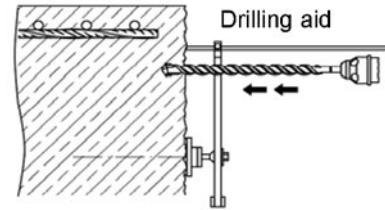

Drilling method	Bar diameter ϕ	Without drilling aid	With drilling aid
Hammer drilling (HD) and (HDB) ²⁾	< 25 mm	30 mm + 0,06 $l_v \geq 2 \phi$	30 mm + 0,02 $l_v \geq 2 \phi$
	≥ 25 mm	40 mm + 0,06 $l_v \geq 2 \phi$	40 mm + 0,02 $l_v \geq 2 \phi$
Compressed air drilling (CA)	< 25 mm	50 mm + 0,08 l_v	50 mm + 0,02 l_v
	≥ 25 mm	60 mm + 0,08 $l_v \geq 2 \phi$	60 mm + 0,02 $l_v \geq 2 \phi$

¹⁾ see Annex B 2, Figure B1 and Annex B 3, Figure B2

²⁾ HDB = hollow drill bit Hilti TE-CD and TE-YD

Comments: The minimum concrete cover acc. EN 1992-1-1:2004+AC:2010 must be observed

Table B2: Dispensers and corresponding maximum embedment depth $l_{v,max}$

Rebar / Hilti Tension anchor HZA-R	Dispenser	
		HDM 330, HDM 500, HDE 500
	Concrete temp. $\geq -10^\circ\text{C}$	Concrete temp. $> 0^\circ\text{C}$
ϕ [mm]	$l_{v,max}$ [mm]	$l_{v,max}$ [mm]
8 to 32 HZA-R M12 to M24	700	1000

Table B3: Working time t_{work} and minimum curing time t_{cure}







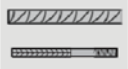

Temperature in the anchorage base [$^\circ\text{C}$]	Maximum working time t_{work} ¹⁾	Minimum curing time t_{cure}
-10 to -5	1,5 hour	7 hour
-4 to +0	50 min	4 hour
+1 to +5	25 min	2 hour
+6 to +10	15 min	75 min
+11 to +20	7 min	45 min
+21 to +30	4 min	30 min
+31 to +40	3 min	30 min

Injection system Hilti HIT-HY 200-A for rebar connection

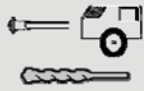
Intended use
Minimum concrete cover / Maximum embedment depth
Working time and minimum curing time

Annex B 4

Table B4: Installation tools for drilling with hammer drill (HD) or compressed air drill (CA)

Elements	Drill and clean					Installation			
	Hammer drilling (HD)	Compressed air drill (CA)	Steel brush	Air Nozzle	Extension for air nozzle	Piston plug	Extension for piston plug	Maximum embedment depth	
									
ϕ [mm]	d_0 [mm]	d_0 [mm]	HIT-RB	HIT-DL		HIT-SZ		l_v or $l_{e,ges}$ [mm]	
8	10	-	10	10	HIT-DL 10/0,8 or HIT-DL V10/1	-	HIT-VL 9/1,0	250	
	12	-	12	12		12		1000	
10	12	-	12	12		12		250	
	14	-	14	14		14	1000		
12 / HZA-R M12	14	-	14	14		14	250		
	16	-	16	16		16	1000		
	-	17	18	16		18	1000		
14	18	17	18	18		18	1000		
	20	-	20	20		20	1000		
16 / HZA-R M16	-	20	22	20		22	1000		
	22	22	22	22	22	1000			
20 HZA-R M20	25	-	25	25	HIT-DL 16/0,8 or HIT-DL B and/or HIT-VL 16/0,7 and/or HIT-VL 16	25	HIT-VL 16/0,7	1000	
	-	26	28	25		28		1000	
22	28	28	28	28		28		1000	
24	32	32	32	32		32	1000		
25 / HZA-R M24	32	32	32	32		32	HIT-VL 16	1000	
	26	35	35			35		1000	
28	35	35	35			35		35	1000
	-	35	35			35		35	1000
30	37	-	37			37		37	1000
	40	40	40			40		40	1000







Assemble extension HIT-VL 16/0.7 with coupler HIT-DL K for deeper anchor holes.

Injection system Hilti HIT-HY 200-A for rebar connection

Intended use
Installation tools for drilling with hammer drill (HD) or compressed air drill (CA)

Annex B 5

**Table B5: Installation tools
for drilling with hollow drill bit (HDB) --- no cleaning required**

Elements	Drill (no cleaning required)				Installation			
Rebar / HZA-R	Hammer drilling, hollow drill bit (HDB)	Steel brush	Air Nozzle	Extension for air nozzle	Piston plug	Extension for piston plug	Maximum embed- ment depth	
	 TE-CD / TE-YD							
ϕ [mm]	d_0 [mm]	HIT-RB	HIT-DL		HIT-SZ		l_v or $l_{e,ges}$ [mm]	
8	12	No cleaning required				12	HIT-VL	200
10	12					12	HIT-VL	200
	14					14	HIT-VL	240
12 / HZA-R M12	14					14		240
	16					16	11/1,0	1000
14	18					18	1000	
16 / HZA-R M16	20					20	1000	
18	22					22	HIT-VL	1000
20 / HZA-R M20	25					25	16/0,7 and/or	1000
22	28					28	HIT-VL	1000
24	32					32	16	1000
25 / HZA-R M24	32					32		1000

Assemble extension HIT-VL 16/0.7 with coupler HIT-DL K for deeper anchor holes.

Injection system Hilti HIT-HY 200-A for rebar connection

Intended use
Installation tools for drilling with hollow drill bit (HDB)

Annex B 6

Safety Regulations:



Review the Material Safety Data Sheet (MSDS) before use for proper and safe handling!

Wear well-fitting protective goggles and protective gloves when working with Hilti HIT-HY 200-A.

Important: Observe the installation instruction provided with each foil pack

1. Drill hole

Note: Before drilling, remove carbonized concrete; clean contact areas (see Annex B 1).

In case of aborted drill hole the drill hole shall be filled with mortar.

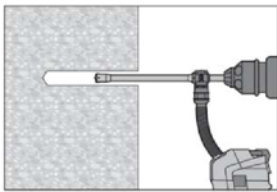

Drill hole to the required embedment depth with an appropriately sized Hilti TE-CD or TE-YD hollow drill bit with Hilti vacuum attachment.

This drilling system removes the dust and cleans the bore hole during drilling when used in accordance with the user's manual. After drilling is complete, proceed to step 3 on Annex B 10.

Drill bit size see Table B5

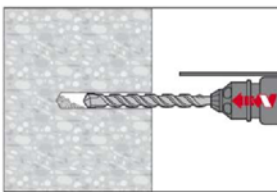

Or:

Drill hole to the required embedment depth using a hammer-drill with carbide drill bit set in rotation hammer mode or a compressed air drill

Drill bit size for:

Hammer drill (HD)

Compressed air drill (CA)

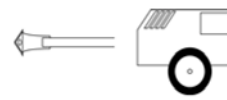

see Table B4

see Table B4

Splicing applications:

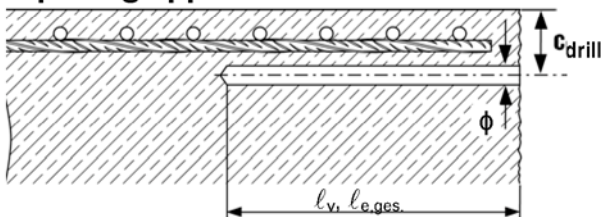

- Measure and control concrete cover c

$$c_{\text{drill}} = c + \phi/2$$

- Drill parallel to surface edge and to existing rebar

- Where applicable use Hilti drilling aid HIT-BH.

Drilling aid

Example: HIT-BH

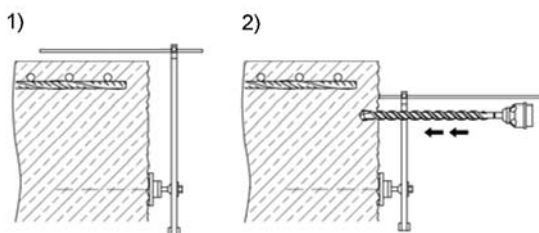

For holes $l_b > 20$ cm use drilling aid.

Three different options can be considered:

A) Hilti drilling aid HIT-BH

B) Slat or spirit level

C) Visual check

Injection system Hilti HIT-HY 200-A for rebar connection

Intended use

Installation instruction I

Annex B 7

2. Clean hole

(not needed with Hilti TE-CD and Hilti TE-YD drill bit)

The borehole must be free of dust, debris, water, ice, oil, grease and other contaminants prior to mortar injection.

Just before setting an rebar the hole must be cleaned of dust and debris by one of the two cleaning methods described below:

2.1. Compressed air cleaning:

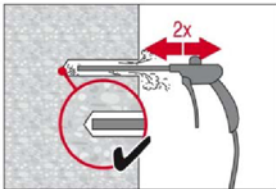

Blowing

2 times from the back of the hole with oil-free compressed air (min. 6 bar at 100 litres per minute (LPM)) until return air stream is free of noticeable dust.

Bore hole diameter ≥ 32 mm the compressor must supply a minimum air flow of 140 m³/hour.

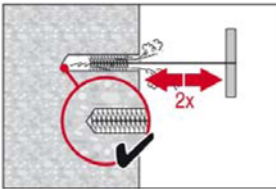

Brushing

2 times with the specified brush size (brush diameter \geq borehole diameter) by inserting the round steel brush to the back of the hole in a twisting motion. The brush shall produce natural resistance as it enters the anchor hole. If this is not the case, please use a new brush or a brush with a larger diameter.

For appropriate brushes HIT-RB see Table B4.

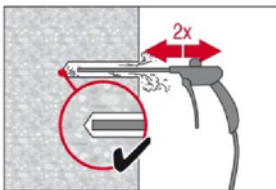

Blowing

2 times again with compressed air until return air stream is free of noticeable dust.

If required use additional accessories and extensions for air nozzle and brush to reach back of hole.

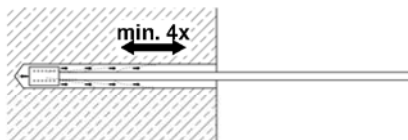

Deep Boreholes – Blowing:

For boreholes deeper than 250 mm (for $\phi = 8$ mm – 12 mm) or deeper than $20 \cdot \phi$ (for $\phi > 12$ mm) use the appropriate air nozzle Hilti HIT-DL (see Table B4)

Safety tip: Do not inhale concrete dust.

The application of the Hilti HIT-DRS dust collector is recommended.

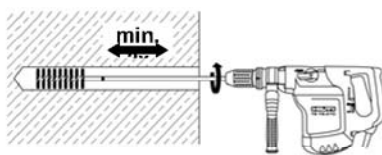

Deep boreholes – brushing

For boreholes deeper than 250 mm (for $\phi = 8$ mm – 12 mm) or deeper than $20 \cdot \phi$ (for $\phi > 12$ mm) use machine brushing and brush extensions HIT-RBS.

Screw the round steel brush HIT-RB in one end of the brush extension(s) HIT-RBS, so that the overall length of the brush is sufficient to reach the base of the borehole. Attach the other end of the extension to the TE-C/TE-Y chuck.

Safety tip:

- Start machine brushing operation slowly.
- Start brushing operation once brush is inserted in borehole.

Injection system Hilti HIT-HY 200-A for rebar connection

Annex B 8

Intended use
Installation instruction II

2.2. Manual cleaning:

Manual cleaning is permitted for hammer drilled boreholes up to hole diameters $d_0 \leq 20$ mm and depths l_v or $l_{e,ges.} \leq 160$ mm.

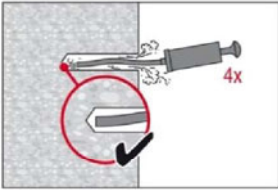

Blowing

4 strokes with Hilti blow-out pump from the back of the hole until return air stream is free of noticeable dust.

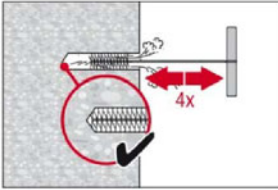

Brushing

4 times with the specified brush size (brush diameter \geq borehole diameter d_0) by inserting the round steel wire brush to the back of the hole with a twisting motion. The brush shall produce natural resistance as it enters the anchor hole. If this is not the case, please use a new brush or a brush with a larger diameter.

For appropriate brushes HIT-RB see Table B4.

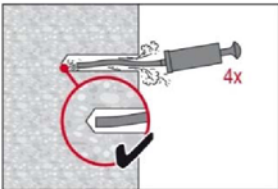

Blowing

4 strokes with Hilti blow-out pump from the back of the hole until return air stream is free of noticeable dust



Manual Cleaning (MC):

Hilti hand pump recommended for blowing out bore holes with diameters $d_0 \leq 20$ mm and bore hole depth $h_0 \leq 160$ mm.

Injection system Hilti HIT-HY 200-A for rebar connection

Annex B 9

Intended use
Installation instruction III

3. Rebar preparation and foil pack preparation

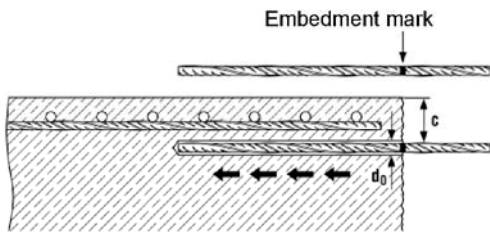

Before use, make sure the rebar is dry and free of oil or other residue.

Mark the embedment depth on the rebar

(e.g. with tape) → l_v

Insert Rebar in borehole, to verify hole and setting depth l_v resp.

$l_{e,ges}$

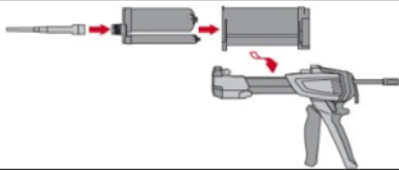

Injection system preparation.

- Observe the Instruction for Use of the dispenser and of the mortar
- Tightly attach Hilti HIT-RE-M mixing nozzle to foil pack manifold.
- Insert foil pack into foil pack holder and swing holder into the dispenser.

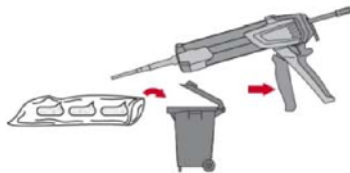

Discard initial mortar. The foil pack opens automatically as dispensing is initiated. Depending on the size of the foil pack an initial amount of mortar has to be discarded.

After changing a mixing nozzle, the first few trigger pulls must be discarded as described above. For each new foil pack a new mixing nozzle must be used

Discard quantities are:

- 2 strokes for 330 ml foil pack,
- 3 strokes for 500 ml foil pack,
- 4 strokes for 500 ml foil pack < 5 °C,

4. Inject mortar into borehole

Forming air pockets shall be avoided.

4.1. Injection method for borehole depth ≤ 250 mm:

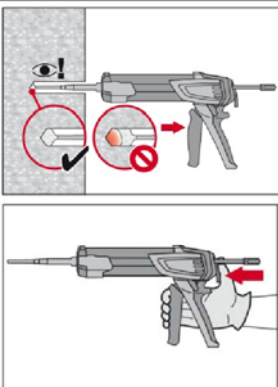

Inject the mortar from the back of the hole towards the front and slowly withdraw the mixing nozzle step by step after each trigger pull.

Fill holes approximately 2/3 full, or as required to ensure that the annular gap between the rebar and the concrete is completely filled with mortar over the embedment length.

After injecting, depressurize the dispenser by pressing the release trigger. This will prevent further mortar discharge from the mixing nozzle.

Injection system Hilti HIT-HY 200-A for rebar connection

Intended use
Installation instruction IV

Annex B 10

4.2. Injection method for borehole depth > 250 mm or overhead applications:

Piston plug
HIT-SZ

Injection extension
HIT-VL



Assemble mixing nozzle HIT-RE-M, extension(s) and piston plug HIT-SZ (see Tables B4 and B5)

For combinations of several injection extensions use coupler HIT-VL K. A substitution of the injection extension for a plastic hose or a combination of both is permitted.

The combination of HIT-SZ piston plug with HIT-VL 16 pipe and then HIT-VL 16 tube support proper injection.



Mortar level mark

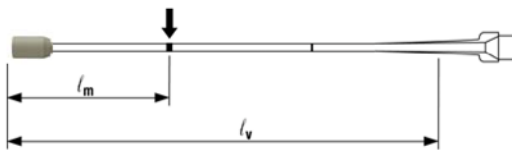

Mark the required mortar level l_m and embedment depth l_b resp. $l_{e,ges}$ with tape or marker on the injection extension.

A) Estimation: $l_m = 1/3 \cdot l_v$ or $l_m = 1/3 \cdot l_{e,ges}$

B) Precise formula for optimum mortar volume:

$$l_m = l_v \text{ or } l_{e,ges} \times \left(1,2 \times \frac{\phi^2}{d_0^2} - 0,2 \right) \text{ [mm]}$$

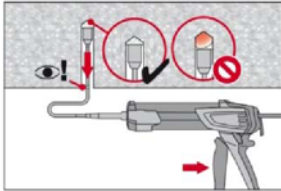

Insert piston plug to back of the hole. Begin injection allowing the pressure of the injected adhesive mortar to push the piston plug towards the front of the hole.

Fill holes approximately 2/3 full, or as required to ensure that the annular gap between the rebar and the concrete is completely filled with adhesive over the embedment length.

Injection until the mortar level mark l_m becomes visible.

After injecting, depressurize the dispenser by pressing the release trigger. This will prevent further mortar discharge from the mixing nozzle.

Maximum embedment depth see Tables B2, B4 and B5

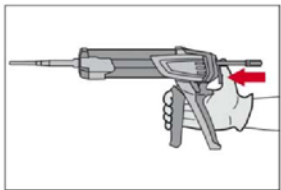

Injection system Hilti HIT-HY 200-A for rebar connection

Intended use
Installation instruction V

Annex B 11

5. Insert rebar

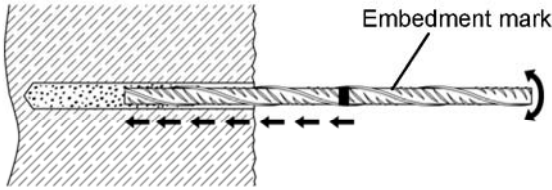

For ease installation insert the rebar slowly twisted into the borehole until the embedment mark is at the concrete surface level.

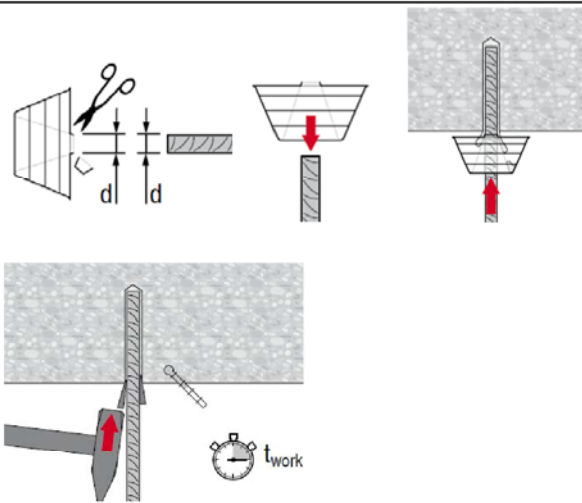

Overhead application:

During insertion of the rebar mortar might flow out of the bore hole. For collection of the flowing mortar HIT-OHC may be used.

Support the rebar and secure it from falling till mortar started to harden, e.g. using wedges HIT-OHW

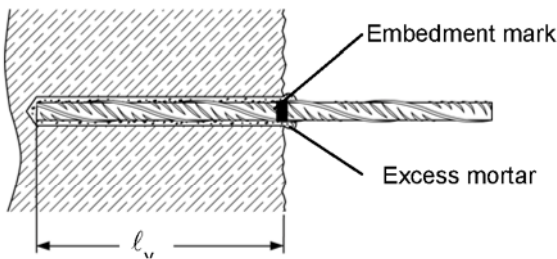

After installing the rebar the annular gap must be completely filled with mortar.

Proper installation

- Desired anchoring embedment is reached $\cdot l_v$; embedment mark at concrete surface.
- Excess mortar flows out of the borehole after the rebar has been fully inserted until the embedment mark.

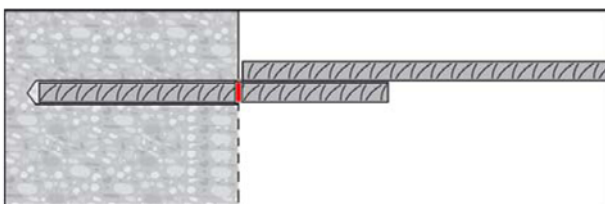

Observe the working time " t_{work} ", which varies according to temperature of base material. Minor adjustments of the rebar position may be performed during the working time.

" t_{work} " see Table B3

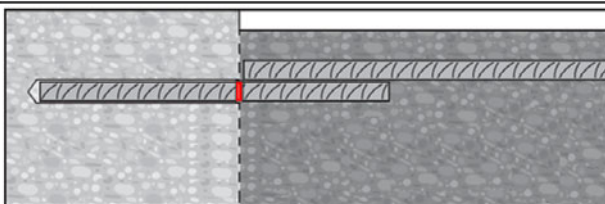

Full load may be applied only after the curing time " t_{cure} " has elapsed (see Table B3)

Injection system Hilti HIT-HY 200-A for rebar connection

Intended use
Installation instruction VI

Annex B 12

Minimum anchorage length and minimum lap length

The minimum anchorage length $\ell_{b,min}$ and the minimum lap length $\ell_{0,min}$ according to EN 1992-1-1:2004+AC:2010 ($\ell_{b,min}$ acc. to Eq. 8.6 and Eq. 8.7 and $\ell_{0,min}$ acc. to Eq. 8.11) shall be multiply by a factor according to Table C1.

Table C1: Factor related to concrete class and drilling method

Concrete class	Drilling method	Factor
C12/15 to C50/60	Hammer drilling (HD) and hammer drilling with hollow drill bit (HDB) and compressed air drilling (CA)	1,0

Table C2: Design values of the ultimate bond resistance f_{bd} in N/mm² for Hammer drilling (HD) and (HDB) and Compressed air drilling (CA)
according to EN 1992-1-1:2004+AC:2010 for good bond conditions
(for all other bond conditions multiply the values by 0.7)

Rebar / Hilti tension anchor HZA-R	bond resistance f_{bd} [N/mm ²]								
	Concrete class								
ϕ [mm]	C12/15	C16/20	C20/25	C25/30	C30/37	C35/45	C40/50	C45/55	C50/60
8 to 32 / HZA-R M12 to M24	1,6	2,0	2,3	2,7	3,0	3,4	3,7	4,0	4,3

Injection system Hilti HIT-HHY 200-A for rebar connection

Performances
Minimum anchorage length and minimum lap length
Design values of ultimate bond resistance f_{bd}

Annex C 1