

Approval body for construction products
and types of construction

Bautechnisches Prüfamt

An institution established by the Federal and
Laender Governments



European Technical Assessment

ETA-02/0030
of 28 October 2015

English translation prepared by DIBt - Original version in German language

General Part

Technical Assessment Body issuing the
European Technical Assessment:

Deutsches Institut für Bautechnik

Trade name of the construction product

Highload Anchor SZ

Product family
to which the construction product belongs

Torque controlled expansion anchor for use
in concrete

Manufacturer

MKT
Metall-Kunststoff-Technik GmbH & Co. KG
Auf dem Immel 2
67685 Weilerbach

Manufacturing plant

MKT
Metall-Kunststoff-Technik GmbH & Co. KG
Auf dem Immel 2
67685 Weilerbach

This European Technical Assessment
contains

20 pages including 3 annexes

This European Technical Assessment is
issued in accordance with Regulation (EU)
No 305/2011, on the basis of

Guideline for European technical approval of "Metal
anchors for use in concrete", ETAG 001 Part 2: "Torque
controlled expansion anchors", April 2013,
used as European Assessment Document (EAD)
according to Article 66 Paragraph 3 of Regulation (EU)
No 305/2011.

The European Technical Assessment is issued by the Technical Assessment Body in its official language. Translations of this European Technical Assessment in other languages shall fully correspond to the original issued document and shall be identified as such.

Communication of this European Technical Assessment, including transmission by electronic means, shall be in full. However, partial reproduction may only be made with the written consent of the issuing Technical Assessment Body. Any partial reproduction shall be identified as such.

This European Technical Assessment may be withdrawn by the issuing Technical Assessment Body, in particular pursuant to information by the Commission in accordance with Article 25(3) of Regulation (EU) No 305/2011.

Specific Part

1 Technical description of the product

The MKT Highload Anchor SZ is an anchor made of galvanised steel or made of stainless steel which is placed into a drilled hole and anchored by torque-controlled expansion. The following anchor types are covered:

- Anchor type SZ-B with threaded bolt,
- Anchor type SZ-S with hexagon head screw,
- Anchor type SZ-SK with countersunk washer and countersunk screw.

The product description is given in Annex A.

2 Specification of the intended use in accordance with the applicable European Assessment Document

The performances given in Section 3 are only valid if the anchor is used in compliance with the specifications and conditions given in Annex B.

The verifications and assessment methods on which this European Technical Assessment is based lead to the assumption of a working life of the anchor of at least 50 years. The indications given on the working life cannot be interpreted as a guarantee given by the producer, but are to be regarded only as a means for choosing the right products in relation to the expected economically reasonable working life of the works.

3 Performance of the product and references to the methods used for its assessment

3.1 Mechanical resistance and stability (BWR 1)

Essential characteristic	Performance
Characteristic resistance for static and quasi-static loading	See Annex C1 to C5
Characteristic resistance for seismic performance category C1 and C2	See Annex C6 to C7
Displacements under tension and shear loads	See Annex C9 and C10

3.2 Safety in case of fire (BWR 2)

Essential characteristic	Performance
Reaction to fire	Anchorage satisfy requirements for Class A1
Resistance to fire	See Annex C8

3.3 Safety in use (BWR 4)

The essential characteristics regarding Safety in use are included under the Basic Works Requirement Mechanical resistance and stability.

English translation prepared by DIBt

4 Assessment and verification of constancy of performance (AVCP) system applied, with reference to its legal base

In accordance with guideline for European technical approval ETAG 001, April 2013 used as European Assessment Document (EAD) according to Article 66 Paragraph 3 of Regulation (EU) No 305/2011 the applicable European legal act is: [96/582/EC].

The system to be applied is: 1

5 Technical details necessary for the implementation of the AVCP system, as provided for in the applicable EAD

Technical details necessary for the implementation of the AVCP system are laid down in the control plan deposited with Deutsches Institut für Bautechnik.

Issued in Berlin on 28 October 2015 by Deutsches Institut für Bautechnik

Uwe Bender
Head of Department

beglaubigt:
Baderschneider

Highload Anchor SZ

Anchor type SZ-B with threaded bolt

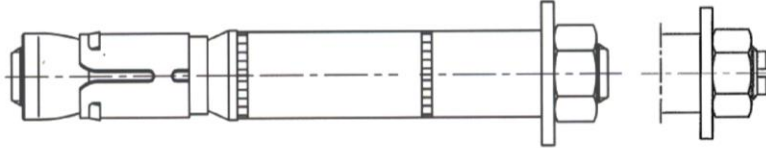

SZ-B (M6-M20)
SZ-B (M8-M16) A4

Anchor type SZ-S with hexagon head screw

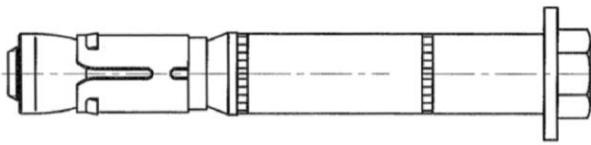

SZ-S (M6-M20)
SZ-S (M8-M16) A4

Anchor type SZ-SK with countersunk washer and countersunk screw

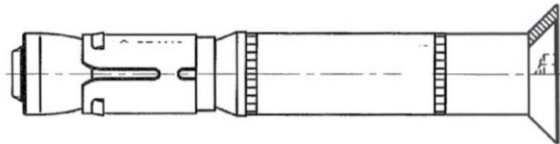

SZ-SK (M6-M12)
SZ-SK (M8-M12) A4

Installation condition

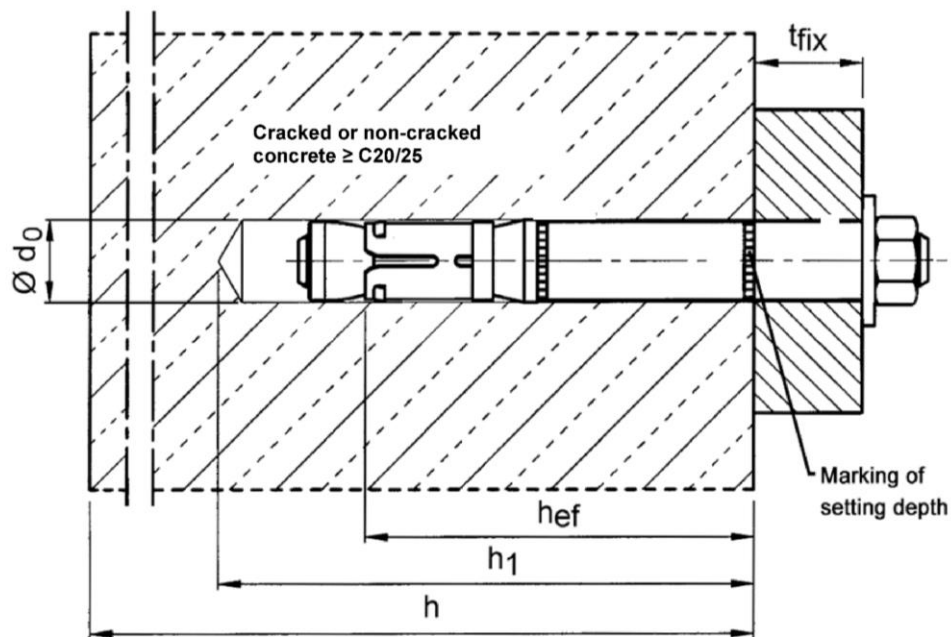

Highload Anchor SZ

Product description
Product and installation situation

Annex A1

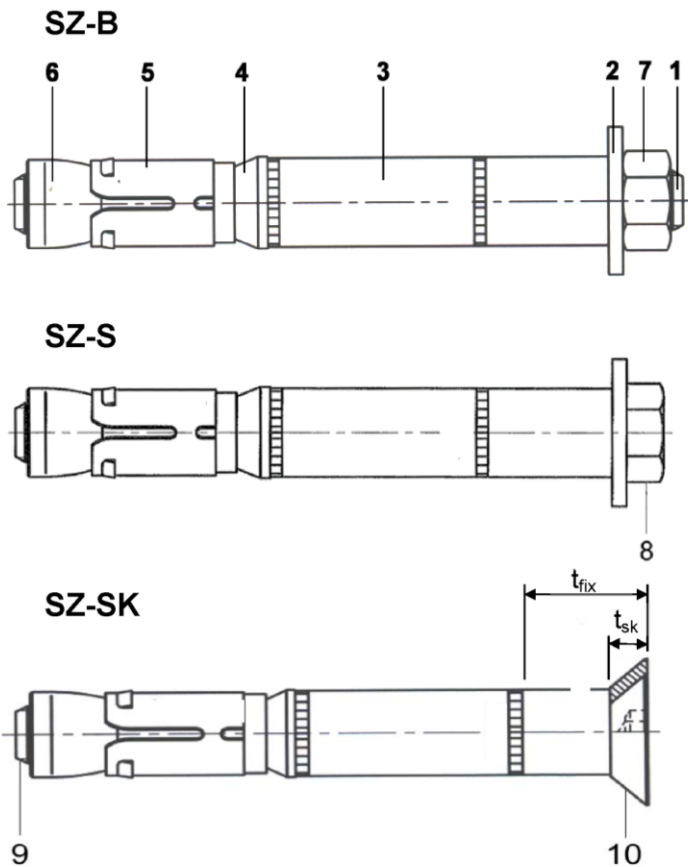

Marking:

expansion sleeve:

- Identifying mark of manufacturing plant ◇
- additional marking of stainless steel A4 A4
- Trade name (alternatively on distance sleeve) SZ
- size of thread (alternatively on distance sleeve) M10

Distance sleeve:

- Diameter 15
- max. thickness of fixture 25
- additional marking for countersunk version SK

additional marking on the washer of anchor size SZ 24/M16L L

Table A1: Designation of anchor parts and materials

Part	Designation	Materials galvanised $\geq 5 \mu\text{m}$, acc. to EN ISO 4042:1999	Stainless steel A4
1	Threaded bolt	Steel, Strength class 8.8, EN ISO 898-1:2013	Stainless steel, 1.4401, 1.4404 or 1.4571, EN 10088:2005
2	Washer	Steel, EN 10139:1997	Stainless steel, 1.4401, 1.4404 or 1.4571, EN 10088:2005
3	Distance sleeve	Precision steel tubes DIN 2394/2393	Stainless steel, 1.4401, 1.4404 or 1.4571, EN 10088:2005
4	Ring	Polyethylene	Polyethylene
5	Expansion sleeve	Steel, EN 10139:1997	Stainless steel, 1.4401, 1.4404 or 1.4571, EN 10088:2005
6	Threaded cone	Steel, Strength class 8, EN ISO 898-2:2012	Stainless steel, 1.4401, 1.4404 or 1.4571, EN 10088:2005
7	Hexagon nut	Steel, Strength class 8, EN ISO 898-2:2012	ISO 3506, strength class 70, stainless steel 1.4401 or 1.4571, EN 10088:2005
8	Hexagon head screw	Steel, Strength class 8.8, EN ISO 898-1:2013	Stainless steel, 1.4401, 1.4404 or 1.4571, EN 10088:2005
9	Countersunk screw	Steel, Strength class 8.8, EN ISO 898-1:2013	Stainless steel, 1.4401, 1.4404 or 1.4571, EN 10088:2005
10	Countersunk washer	Steel, EN 10083-2:2006	Stainless steel, 1.4401, 1.4404 or 1.4571, EN 10088:2005

Highload Anchor SZ

Product description
Marking and materials

Annex A2

Specifications of intended use

Highload Anchor SZ, steel zinc plated	10/M6	12/M8	15/M10	18/M12	24/M16	24/M16L	28/M20
Static or quasi-static action	✓						
Seismic action (SZ-B and SZ-S)	-	C1 + C2					
Fire exposure	R 30 ... R 120						
Highload Anchor SZ, stainless steel A4	12/M8	15/M10	18/M12	24/M16			
Static or quasi-static action	✓						
Seismic action (SZ-B and SZ-S)	C1 + C2						
Fire exposure	R30 ... R120						

Base materials:

- Cracked and non-cracked concrete
- Reinforced or unreinforced normal weight concrete according to EN 206-1:2000
- Strength classes C20/25 to C50/60 according to EN 206-1:2000

Use conditions (Environmental conditions):

- Structures subject to dry internal conditions (zinc plated steel or stainless steel).
- Structures subject to external atmospheric exposure (including industrial and marine environment) and to permanently damp internal condition, if no particular aggressive conditions exist (stainless steel).

Note: Particular aggressive conditions are e.g. permanent, alternating immersion in seawater or the splash zone of seawater, chloride atmosphere of indoor pools or atmosphere with extreme chemical pollution (e.g. in desulphurization plants or road tunnels where de-icing materials are used.)

Design:

- Anchorages are designed under the responsibility of an engineer experienced in anchorages and concrete work.
- Verifiable calculation notes and drawings are prepared taking account of the loads to be anchored. The position of the anchor is indicated on the design drawings (e.g. position of the anchor relative to reinforcement or to supports, etc.).
- Anchorages under static or quasi-static actions are designed in accordance with:
 - ETAG 001, Annex C, design method A, Edition August 2010 or
 - CEN/TS 1992-4:2009, design method A
- Anchorages under seismic actions (cracked concrete) are designed in accordance with:
 - EOTA Technical Report TR 045, Edition February 2013
 - Anchorages shall be positioned outside of critical regions (e.g. plastic hinges) of the concrete structure
 - Fastenings in stand-off installation or with a grout layer are not allowed
- Anchorages under fire exposure are designed in accordance with:
 - EOTA Technical Report TR 020, Edition May 2004 or
 - CEN/TS 1992-4: 2009, Annex D

(It must be ensured that local spalling of the concrete cover does not occur)

Installation:

- Anchor installation carried out by appropriately qualified personnel and under the supervision of the person responsible for technical matters of the site.
- In case of aborted hole: new drilling at a minimum distance away of twice the depth of the aborted hole or smaller distance if the aborted drill hole is filled with high strength mortar and if under shear or oblique tension load it is not in the direction of load application.
- Anchor installation such that the effective anchorage depth is complied with. This compliance is ensured when the embedment mark of the anchor does no more exceed the concrete surface.

Highload Anchor SZ

Intended use
Specifications

Annex B1

Installation instructions

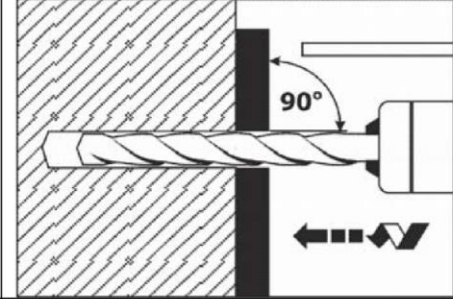
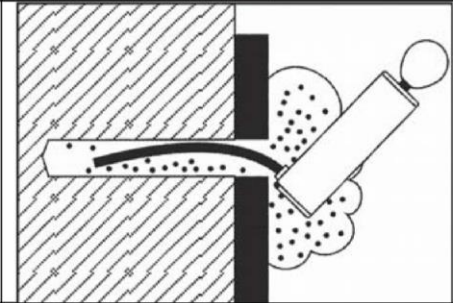
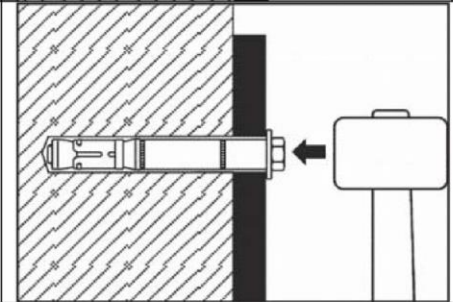
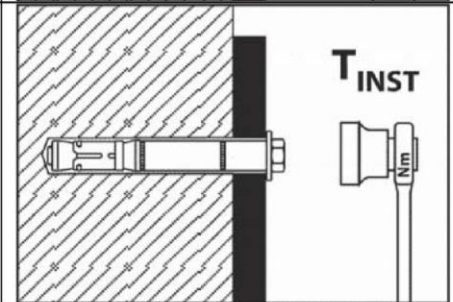
1		Drill hole perpendicular to concrete surface.
2		Blow out dust.
3		Drive in anchor.
4		Apply tightening torque T_{inst} by using calibrated torque wrench.

electronic copy of the eta by dibt: eta-02/0030

Highload Anchor SZ

Intended use
Installation instructions

Annex B2

Table B1: Installation parameters, steel zinc plated

Anchor size		10/M6	12/M8	15/M10	18/M12	24/M16	24/M16L	28/M20
Size of thread	[-]	M6	M8	M10	M12	M16	M16	M20
Effective anchorage depth	h_{ef} [mm]	50	60	71	80	100	115	125
Nominal diameter of drill bit	$d_0 =$ [mm]	10	12	15	18	24	24	28
Cutting diameter of drill bit	$d_{cut} \leq$ [mm]	10,45	12,5	15,5	18,5	24,55	24,55	28,55
Depth of drill hole	$h_1 \geq$ [mm]	65	80	95	105	130	145	160
Diameter of clearance hole in the fixture	$d_f \leq$ [mm]	12	14	17	20	26	26	31
Thickness of fixture	$t_{fix\ min}$ [mm]	0	0	0	0	0	0	0
SZ-B and SZ-S	$t_{fix\ max}$ [mm]	200	200	200	250	300	300	300
Thickness of fixture	$t_{fix\ min}^{2)}$ [mm]	8	10	14	18	-	-	-
SZ-SK	$t_{fix\ max}$ [mm]	200	200	200	250	-	-	-
Thickness of countersunk washer SZ-SK	t_{sk} [mm]	4	5	6	7	-	-	-
Required setting torque	T_{inst} (SZ-B, SZ-S) [Nm]	15	30	50	80	160	160	280
	T_{inst} (SZ-SK) [Nm]	10	25	55	70	-	-	-
Minimum thickness of member	h_{min} [mm]	100	120	140	160	200	230	250
Minimum spacing ^{1) 3)}	s_{min} [mm]	50	60	70	80	100	100	125
	for $c \geq$ [mm]	80	100	120	160	180	180	300
Minimum edge distance ^{1) 3)}	c_{min} [mm]	50	60	70	80	100	100	180
	for $s \geq$ [mm]	100	120	175	200	220	220	540

¹⁾ Intermediate values by linear interpolation

²⁾ Depending on the existing shear load, the thickness of the fixture may be reduced to the thickness of the countersunk washer t_{sk} (see Annex A2). It must be verified that the present shear load can be transferred completely into the distance sleeve (bearing of hole).

³⁾ For fire exposure from more than one side $c \geq 300$ mm or $c_{min} \geq 300$ mm must be applied.

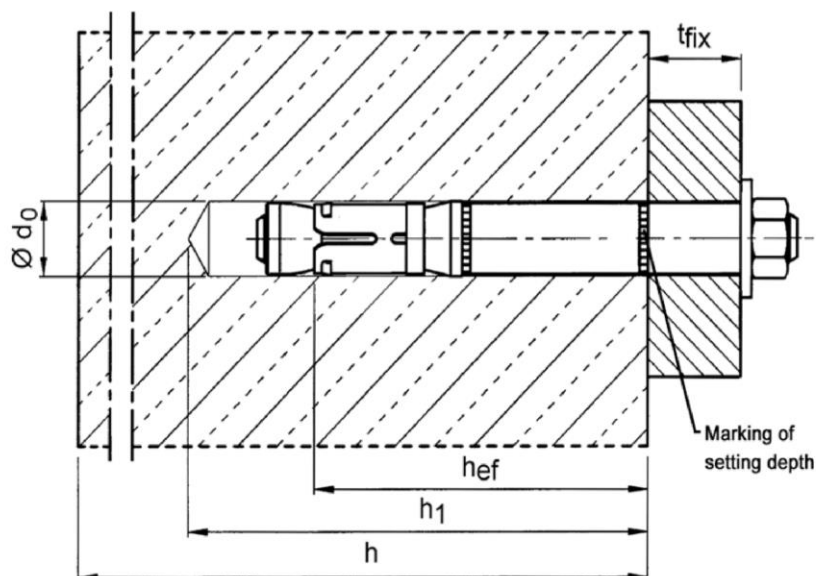

Highload Anchor SZ

Intended use
Installation parameters, steel zinc plated

Annex B3

Table B2: Installation parameters, stainless steel A4

Anchor size			12/M8	15/M10	18/M12	24/M16
Size of thread		[-]	M8	M10	M12	M16
Effective anchorage depth	h_{ef}	[mm]	60	71	80	100
Nominal diameter of drill bit	$d_0 =$	[mm]	12	15	18	24
Cutting diameter of drill bit	$d_{cut} \leq$	[mm]	12,5	15,5	18,5	24,55
Depth of drill hole	$h_1 \geq$	[mm]	80	95	105	130
Diameter of clearance hole in the fixture	$d_f \leq$	[mm]	14	17	20	26
Thickness of fixture SZ-B and SZ-S	$t_{fix\ min}$	[mm]	0	0	0	0
	$t_{fix\ max}$	[mm]	200	200	250	300
Thickness of fixture SZ-SK	$t_{fix\ min}^{2)}$	[mm]	10	14	18	-
	$t_{fix\ max}$	[mm]	200	200	250	-
Thickness of countersunk washer SZ-SK	t_{sk}	[mm]	5	6	7	-
Required setting torque	T_{inst} (SZ-B)	[Nm]	35	55	90	170
	T_{inst} (SZ-S)	[Nm]	30	50	80	170
	T_{inst} (SZ-SK)	[Nm]	17,5	42,5	50	-
Minimum thickness of member	h_{min}	[mm]	120	140	160	200
Minimum spacing ^{1) 3)} cracked concrete	s_{min}	[mm]	50	60	70	80
	for $c \geq$	[mm]	80	120	140	180
Minimum edge distance ^{1) 3)} cracked concrete	c_{min}	[mm]	50	60	70	80
	for $s \geq$	[mm]	80	120	160	200
Minimum spacing ^{1) 3)} non-cracked concrete	s_{min}	[mm]	50	60	70	80
	for $c \geq$	[mm]	80	120	140	180
Minimum edge distance ^{1) 3)} non-cracked concrete	c_{min}	[mm]	50	85	70	180
	for $s \geq$	[mm]	80	185	160	80

¹⁾ Intermediate values by linear interpolation

²⁾ Depending on the existing shear load, the thickness of the fixture may be reduced to the thickness of the countersunk washer t_{sk} (see Annex A2). It must be verified that the present shear load can be transferred completely into the distance sleeve (bearing of hole).

³⁾ For fire exposure from more than one side $c \geq 300$ mm or $c_{min} \geq 300$ mm applies.

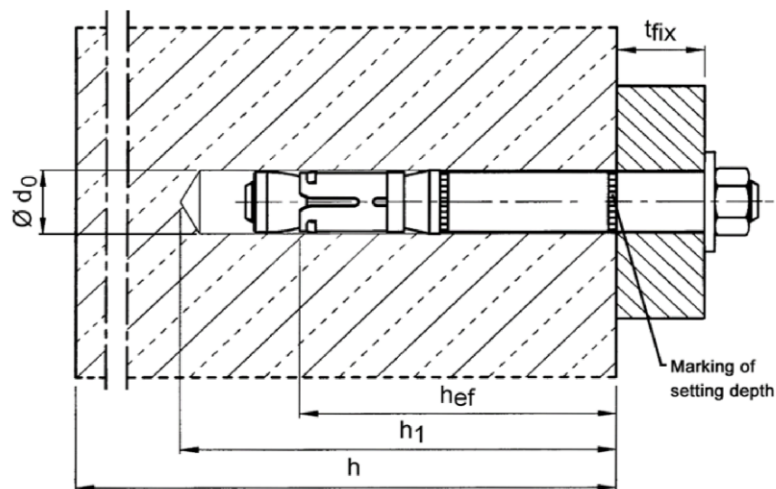

Highload Anchor SZ

Intended use
Installation parameters, stainless steel A4

Annex B4

Table C1: Characteristic values for tension load, cracked concrete under static or quasi-static action, steel zinc plated

Anchor size		10/M6	12/M8	15/M10	18/M12	24/M16	24/M16L	28/M20
Installation safety factor	$\gamma_2 = \gamma_{inst}$ [-]	1,0						
Steel failure								
Characteristic resistance	$N_{Rk,s}$ [kN]	16	29	46	67	126	126	196
Partial safety factor	γ_{Ms} [-]	1,5						
Pull-out failure								
Characteristic resistance in cracked concrete C20/25	$N_{Rk,p}$ [kN]	5	12	16	1)	1)	1)	1)
Increasing factor for $N_{Rk,p}$	ψ_C [-]	$\left(\frac{f_{ck,cube}}{25}\right)^{0,5}$						
Concrete cone failure								
Effective anchorage depth	h_{ef} [mm]	50	60	71	80	100	115	125
Factor acc. to CEN/TS 1992-4	k_{cr} [-]	7,2						

1) Pull-out is not decisive.

Table C2: Characteristic values for tension load, cracked concrete under static or quasi-static action, stainless steel A4

Anchor size		12/M8	15/M10	18/M12	24/M16
Installation safety factor	$\gamma_2 = \gamma_{inst}$ [-]	1,0			
Steel failure					
SZ-B					
Characteristic resistance	$N_{Rk,s}$ [kN]	26	41	60	110
Partial safety factor	γ_{Ms} [-]	1,5			
SZ-S and SZ-SK					
Characteristic resistance	$N_{Rk,s}$ [kN]	26	41	60	110
Partial safety factor	γ_{Ms} [-]	1,87			
Pull-out failure					
Characteristic resistance in cracked concrete C20/25	$N_{Rk,p}$ [kN]	9	16	1)	1)
Increasing factor for $N_{Rk,p}$	ψ_C [-]	$\left(\frac{f_{ck,cube}}{25}\right)^{0,5}$			
Concrete cone failure					
Effective anchorage depth	h_{ef} [mm]	60	71	80	100
Factor acc. to CEN/TS 1992-4	k_{cr} [-]	7,2			

1) Pull-out is not decisive.

Highload Anchor SZ

Performance

Characteristic values for **tension load** in **cracked concrete** under static or quasi-static action

Annex C1

Table C3: Characteristic values for tension load in non-cracked concrete, under static or quasi-static action, steel zinc plated

Anchor size			10/M6	12/M8	15/M10	18/M12	24/M16	24/M16L	28/M20	
Installation safety factor	$\gamma_2 = \gamma_{inst}$	[-]	1,0							
Steel failure										
Characteristic resistance	$N_{Rk,s}$	[kN]	16	29	46	67	126	126	196	
Partial safety factor	γ_{Ms}	[-]	1,5							
Pull-out failure										
Characteristic resistance in non-cracked concrete C20/25	$N_{Rk,p}$	[kN]	1)	20	30	1)	1)	1)	1)	
Splitting failure (The higher resistance of Case 1 and Case 2 may be applied.)										
Case 1										
Characteristic resistance in concrete C20/25	$N^0_{Rk,sp}$	[kN]	12 ²⁾	16 ²⁾	25 ²⁾	30 ²⁾	40 ²⁾	70	50 ²⁾	
Spacing	$s_{cr,sp}$	[mm]	3 h_{ef}							
Edge distance	$c_{cr,sp}$	[mm]	1,5 h_{ef}							
Case 2 (acc. to ETAG 001, Annex C, equation (5.3))										
Spacing	$s_{cr,sp}$	[mm]	5 h_{ef}					3 h_{ef}	5 h_{ef}	
Edge distance	$c_{cr,sp}$	[mm]	2,5 h_{ef}					1,5 h_{ef}	2,5 h_{ef}	
Increasing factor for $N_{Rk,p}$ and $N^0_{Rk,sp}$	ψ_C	[-]	$\left(\frac{f_{ck,cube}}{25}\right)^{0,5}$							
Concrete cone failure										
Effective Anchorage depth	h_{ef}	[mm]	50	60	71	80	100	115	125	
Factor acc. to CEN/TS 1992-4	k_{ucr}	[-]	10,1							

¹⁾ Pull-out is not decisive.

²⁾ For the proof against splitting failure, $N^0_{Rk,c}$ has to be replaced by $N^0_{Rk,sp}$.

Highload Anchor SZ

Performance

Characteristic values for **tension load in non-cracked concrete**, under static or quasi-static action, **steel zinc plated**

Annex C2

Table C4: Characteristic values for tension load in non-cracked concrete under static or quasi-static action, stainless steel A4

Anchor size			12/M8	15/M10	18/M12	24/M16
Installation safety factor	$\gamma_2 = \gamma_{inst}$	[-]	1,0			
Steel failure						
SZ-B						
Characteristic resistance	$N_{Rk,s}$	[kN]	26	41	60	110
Partial safety factor	γ_{Ms}	[-]	1,5			
SZ-S and SZ-SK						
Characteristic resistance	$N_{Rk,s}$	[kN]	26	41	60	110
Partial safety factor	γ_{Ms}	[-]	1,87			
Pull-out failure						
Characteristic resistance in non-cracked concrete C20/25	$N_{Rk,p}$	[kN]	16	25	35	¹⁾
Increasing factor for $N_{Rk,p}$	ψ_C	[-]	$\left(\frac{f_{ck,cube}}{25}\right)^{0,5}$			
Splitting failure						
Spacing	$s_{cr,sp}$	[mm]	360	470	530	600
Edge distance	$c_{cr,sp}$	[mm]	180	235	265	300
Concrete cone failure						
Effective anchorage depth	h_{ef}	[mm]	60	71	80	100
Factor acc. to CEN/TS 1992-4	k_{ucr}	[-]	10,1			

¹⁾ Pull-out is not decisive.

Highload Anchor SZ

Performance

Characteristic values for **tension loads** in non-cracked concrete under static or quasi-static action, **stainless steel A4**

Annex C3

Table C5: Characteristic values of shear load under static or quasi-static action, steel zinc plated

Anchor size			10/M6	12/M8	15/M10	18/M12	24/M16	24/M16L	28/M20
Steel failure without lever arm									
SZ-B									
Characteristic resistance	$V_{Rk,s}$	[kN]	16	25	36	63	91	91	122
Ductility factor	k_2	[-]	1,0						
Partial safety factor	γ_{Ms}	[-]	1,25						
SZ-S and SZ-SK									
Characteristic resistance	$V_{Rk,s}$	[kN]	18	30	48	73	126	126	150
Ductility factor	k_2	[-]	0,8						
Partial safety factor	γ_{Ms}	[-]	1,25						
Steel failure with lever arm									
Characteristic resistance	$M^0_{Rk,s}$	[Nm]	12	30	60	105	266	266	519
Partial safety factor	γ_{Ms}	[-]	1,25						
Concrete pry-out failure									
Factor k acc. to ETAG 001, Annex C or k_3 acc. to CEN/TS 1992-4	$k_{(3)}$	[-]	1,8	2,0					
Concrete edge failure									
Effective length of anchor in shear loading	l_f	[mm]	50	60	71	80	100	115	125
Outside diameter of anchor	d_{nom}	[mm]	10	12	15	18	24	24	28

Highload Anchor SZ

Performance
Characteristic values for **shear load** under static or quasi-static action, **steel zinc plated**

Annex C4

Table C6: Characteristic values for shear load under static or quasi-static action, stainless steel A4

Anchor size		12/M8	15/M10	18/M12	24/M16
Steel failure without lever arm					
SZ-B					
Characteristic resistance	$V_{Rk,s}$ [kN]	24	37	62	92
Ductility factor	k_2 [-]	1,0			
Partial safety factor	γ_{Ms} [-]	1,25			
SZ-S and SZ-SK					
Characteristic resistance	$V_{Rk,s}$ [kN]	24	37	62	92
Ductility factor	k_2 [-]	0,8			
Partial safety factor	γ_{Ms} [-]	1,36			
Steel failure with lever arm					
SZ-B					
Characteristic resistance	$M^0_{Rk,s}$ [Nm]	26	52	92	232
Ductility factor	k_2 [-]	1,0			
Partial safety factor	γ_{Ms} [-]	1,25			
SZ-S and SZ-SK					
Characteristic resistance	$M^0_{Rk,s}$ [Nm]	26	52	92	232
Ductility factor	k_2 [-]	0,8			
Partial safety factor	γ_{Ms} [-]	1,56			
Concrete pry-out failure					
Factor k acc. to ETAG 001, Annex C or k_3 acc. to CEN/TS 1992-4	$k_{(3)}$ [-]	2,0			
Concrete edge failure					
Effective length of anchor in shear loading	l_f [mm]	60	71	80	100
Outside diameter of anchor	d_{nom} [mm]	12	15	18	24

Highload Anchor SZ

Performance

Characteristic values for **shear load** under static or quasi-static action, **stainless steel A4**

Annex C5

Table C7: Characteristic values for seismic action, Category C1 and C2, steel zinc plated

Anchor size		12/M8	15/M10	18/M12	24/M16	24/M16L	28/M20	
Tension load								
Installation safety factor	$\gamma_2 = \gamma_{inst}$	[-]	1,0					
Steel failure								
Characteristic tension resistance category C1	$N_{Rk,s,seis,C1}$	[kN]	29	46	67	126	126	196
Characteristic tension resistance category C2	$N_{Rk,s,seis,C2}$	[kN]	29	46	67	126	126	196
Partial safety factor	$\gamma_{Ms,seis}$	[-]	1,5					
Pull-out failure								
Characteristic tension resistance category C1	$N_{Rk,p,seis,C1}$	[kN]	12	16	25	36	44,4	50,3
Characteristic tension resistance category C2	$N_{Rk,p,seis,C2}$	[kN]	5,4	16,4	22,6	29,0	41,2	43,6
Increasing factor for $N_{Rk,p,seis}$	ψ_c	[-]	1,0					
Shear load								
Steel failure without lever arm								
SZ-B								
Characteristic shear resistance category C1	$V_{Rk,s,seis,C1}$	[kN]	18,0	27,1	43,4	51,9	51,9	96,4
Characteristic shear resistance category C2	$V_{Rk,s,seis,C2}$	[kN]	12,7	20,5	31,5	50,1	50,1	67,1
SZ-S								
Characteristic shear resistance category C1	$V_{Rk,s,seis,C1}$	[kN]	18,0	27,1	43,4	51,9	51,9	96,4
Characteristic shear resistance category C2	$V_{Rk,s,seis,C2}$	[kN]	12,7	20,5	31,5	69,3	69,3	67,1
Partial safety factor	$\gamma_{Ms,seis}$	[-]	1,25					
Steel failure with lever arm								
Characteristic resistance	$M^0_{Rk,s,seis}$	[Nm]	no performance determined					

Highload Anchor SZ

Performance
Characteristic values for **seismic action, steel zinc plated**

Annex C6

Table C8: Characteristic values for seismic action, Category C1 and C2, stainless steel A4

Anchor size		12/M8	15/M10	18/M12	24/M16	
Tension load						
Installation safety factor	$\gamma_2 = \gamma_{inst}$	[-]	1,0			
Steel failure						
Characteristic tension resistance, category C1	$N_{Rk,s,seis,C1}$	[kN]	26	41	60	110
Characteristic tension resistance, category C2	$N_{Rk,s,seis,C2}$	[kN]	26	41	60	110
Partial safety factor SZ-B	$\gamma_{Ms,seis}$	[-]	1,5			
Partial safety factor SZ-S	$\gamma_{Ms,seis}$	[-]	1,87			
Pull-out failure						
Characteristic tension resistance, category C1	$N_{Rk,p,seis,C1}$	[kN]	9	16	26	36
Characteristic tension resistance, category C2	$N_{Rk,p,seis,C2}$	[kN]	4,8	16,5	24,8	44,5
Increasing factor for $N_{Rk,p,seis}$	ψ_c	[-]	1,0			
Shear load						
Steel failure without lever arm						
Characteristic shear resistance, category C1	$V_{Rk,s,seis,C1}$	[kN]	9,6	13,3	25,4	75,4
Characteristic shear resistance, category C2	$V_{Rk,s,seis,C2}$	[kN]	9,7	14,0	18,0	32,2
Partial safety factor SZ-B	$\gamma_{Ms,seis}$	[-]	1,25			
Partial safety factor SZ-S	$\gamma_{Ms,seis}$	[-]	1,36			
Steel failure with lever arm						
Characteristic resistance	$M^0_{Rk,s,seis}$	[Nm]	no performance determined			

Highload Anchor SZ

Performance
Characteristic values for **seismic action, stainless steel A4**

Annex C7

Table C9: Characteristic values for tension and shear load under fire exposure in cracked and non-cracked concrete C20/25 to C50/60

Anchor size		10/M6	12/M8	15/M10	18/M12	24/M16	24/M16L	28/M20		
Tension load										
Steel failure										
Steel zinc plated										
Characteristic resistance	R30	$N_{Rk,s,fi}$	[kN]	1,0	1,9	4,3	6,3	11,6	18,3	
	R60			0,8	1,5	3,2	4,6	8,6	13,5	
	R90			0,6	1,0	2,1	3,0	5,0	7,7	
	R120			0,4	0,8	1,5	2,0	3,1	4,9	
Stainless steel A4										
Characteristic resistance	R30	$N_{Rk,s,fi}$	[kN]	-	6,1	10,2	15,7	29,2	-	-
	R60			-	4,4	7,3	11,1	20,6	-	-
	R90			-	2,6	4,3	6,4	12,0	-	-
	R120			-	1,8	2,8	4,1	7,7	-	-
Shear load										
Steel failure without lever arm										
Steel zinc plated										
Characteristic resistance	R30	$V_{Rk,s,fi}$	[kN]	1,0	1,9	4,3	6,3	11,6	18,3	
	R60			0,8	1,5	3,2	4,6	8,6	13,5	
	R90			0,6	1,0	2,1	3,0	5,0	7,7	
	R120			0,4	0,8	1,5	2,0	3,1	4,9	
Stainless steel A4										
Characteristic resistance	R30	$V_{Rk,s,fi}$	[kN]	-	14,3	22,7	32,8	61,0	-	-
	R60			-	11,1	17,6	25,5	47,5	-	-
	R90			-	7,9	12,6	18,3	34,0	-	-
	R120			-	6,3	10,0	14,6	27,2	-	-
Steel failure with lever arm										
Steel zinc plated										
Characteristic resistance	R30	$M^0_{Rk,s,fi}$	[Nm]	0,8	2,0	5,6	9,7	24,8	42,4	
	R60			0,6	1,5	4,1	7,2	18,3	29,8	
	R90			0,4	1,0	2,7	4,7	11,9	17,1	
	R120			0,3	0,8	1,9	3,1	6,6	10,7	
Stainless steel A4										
Characteristic resistance	R30	$M^0_{Rk,s,fi}$	[Nm]	-	6,2	13,2	24,4	61,8	-	-
	R60			-	4,5	9,4	17,2	43,6	-	-
	R90			-	2,7	5,6	10,0	25,3	-	-
	R120			-	1,8	3,6	6,4	16,2	-	-

The characteristic resistances for pull-out failure, concrete cone failure, concrete pry-out and concrete edge failure can be calculated according to TR020 / CEN/TS 1992-4.

Highload Anchor SZ

Performance
Characteristic values for **tension and shear loads** under **fire exposure**

Annex C8

Table C10: Displacements under tension load

Anchor size			10/M6	12/M8	15/M10	18/M12	24/M16	24/M16L	28/M20
Steel, zinc plated									
Tension load in cracked concrete	N	[kN]	2,4	5,7	7,6	12,3	17,1	21,1	24
Displacement	δ_{N0}	[mm]	0,5	0,5	0,5	0,7	0,8	0,7	0,9
	$\delta_{N\infty}$	[mm]	2,0	2,0	1,3	1,3	1,3	1,3	1,4
Tension load in non-cracked concrete	N	[kN]	8,5	9,5	14,3	17,2	24	29,6	34
Displacement	δ_{N0}	[mm]	0,8	1,0	1,1		1,3		0,3
	$\delta_{N\infty}$	[mm]	3,4		1,7		2,3		1,4
Seismic action C2									
Displacement for DLS	$\delta_{N,seis,C2(DLS)}$	[mm]	-	3,3	3,0	5,0	3,0	3,0	4,0
Displacement for ULS	$\delta_{N,seis,C2(ULS)}$	[mm]	-	12,2	11,3	16,0	9,2	9,2	13,8
Stainless steel A4									
Tension load in cracked concrete	N	[kN]	-	4,3	7,6	12,1	17,0	-	-
Displacement	δ_{N0}	[mm]	-	0,5	0,5	1,3	0,5	-	-
	$\delta_{N\infty}$	[mm]	-	1,2	1,6	1,8	1,6	-	-
Tension load in non-cracked concrete	N	[kN]	-	7,6	11,9	16,7	24,1	-	-
Displacement	δ_{N0}	[mm]	-	0,2	0,3	1,2	1,5	-	-
	$\delta_{N\infty}$	[mm]	-	1,1			-	-	-
Seismic action C2									
Displacement for DLS	$\delta_{N,seis,C2(DLS)}$	[mm]	-	4,7	4,5	4,3	4,9	-	-
Displacement for ULS	$\delta_{N,seis,C2(ULS)}$	[mm]	-	13,3	12,7	9,7	10,1	-	-

Highload Anchor SZ

Performance
Displacements under **tension load**

Annex C9

Table C11: Displacements under shear load

Anchor size			10/M6	12/M8	15/M10	18/M12	24/M16	24/M16L	28/M20
Steel, zinc plated									
SZ-B									
Shear load in cracked and non-cracked concrete	V	[kN]	9,1	14	20,7	35,1	52,1	52,1	77
Displacement	δ_{V0}	[mm]	2,5	2,1	2,7	3,0	5,1	5,1	4,3
	$\delta_{V\infty}$	[mm]	3,8	3,1	4,1	4,5	7,6	7,6	6,5
Seismic action C2									
Displacement for DLS	$\delta_{V,seis,C2(DLS)}$	[mm]	-	2,3	3,1	3,0	2,6	2,6	1,6
Displacement for ULS	$\delta_{V,seis,C2(ULS)}$	[mm]	-	4,8	6,4	6,1	6,6	6,6	4,8
SZ-S and SZ-SK									
Shear load in cracked and non-cracked concrete	V	[kN]	10,1	17,1	27,5	41,5	72	72	77
Displacement	δ_{V0}	[mm]	2,9	2,5	3,6	3,5	7,0	7,0	4,3
	$\delta_{V\infty}$	[mm]	4,4	3,8	5,4	5,3	10,5	10,5	6,5
Seismic action C2 (SZ-S)									
Displacement for DLS	$\delta_{V,seis,C2(DLS)}$	[mm]	-	2,3	3,1	3,0	3,3	3,3	1,6
Displacement for ULS	$\delta_{V,seis,C2(ULS)}$	[mm]	-	4,8	6,4	6,1	8,2	8,2	4,8
Stainless steel A4									
Shear load in cracked and non-cracked concrete	V	[kN]	-	13,9	21,1	34,7	50,8	-	-
Displacement	δ_{V0}	[mm]	-	3,4	4,9	4,8	6,7	-	-
	$\delta_{V\infty}$	[mm]	-	5,1	7,4	7,1	10,1	-	-
Seismic action C2									
Displacement for DLS	$\delta_{V,seis,C2(DLS)}$	[mm]	-	2,8	3,1	2,6	3,3	-	-
Displacement for ULS	$\delta_{V,seis,C2(ULS)}$	[mm]	-	5,6	5,8	5,0	6,9	-	-

Highload Anchor SZ

Performance
Displacements under **shear load**

Annex C10